



The Abdus Salam
International Centre for Theoretical Physics



310/1780-12

**ICTP-INFN Advanced Training Course on
FPGA and VHDL for Hardware Simulation and Synthesis
27 November - 22 December 2006**

VHDL & FPGA – Session 4

***Nizar ABDALLH
ACTEL Corp.
2061 Stierlin Court
Mountain View, CA 94043-4655
U.S.A.***

These lecture notes are intended only for distribution to participants



VHDL & FPGA Architectures



Nizar Abdallah, Ph.D.
nizar@ieee.org

- Introduction to FPGA & FPGA Design Flow
- Synthesis I - Introduction
- Synthesis II - Introduction to VHDL
- Synthesis III - Advanced VHDL
- Design verification & timing concepts
- Programmable logic & FPGA architectures
- Actel ProASIC3 FPGA architecture





Design Verification and Timing Concepts



- Timing Driven Synthesis
- Timing Driven Optimization
- Timing Driven Floor-Planner
- Timing Driven Place & Route



■ Simulators

- **Circuit-Level**
- **Timing**
- **Switch-Level**
- **Logic-Level**

■ Verifiers (Pattern Independent)

- **Static Timing Analysis**



- Golden Rule:

Detect Problems as early as possible



What are Timing Constraints?



- Maximum or minimum limits placed on timing paths
- Usually expressed in ns. or ps.
- There are basically 4 types of timing paths in a synthesized digital design:
 - **Input to registers**
 - **Registers to output**
 - **Input to output**
 - **Registers to registers**
- To understand timing paths we first must understand flip-flop timing parameters



- These basic timing paths can apply to:
 - A module within an ASIC/FPGA
 - A whole ASIC/FPGA
 - A system with multiple chips

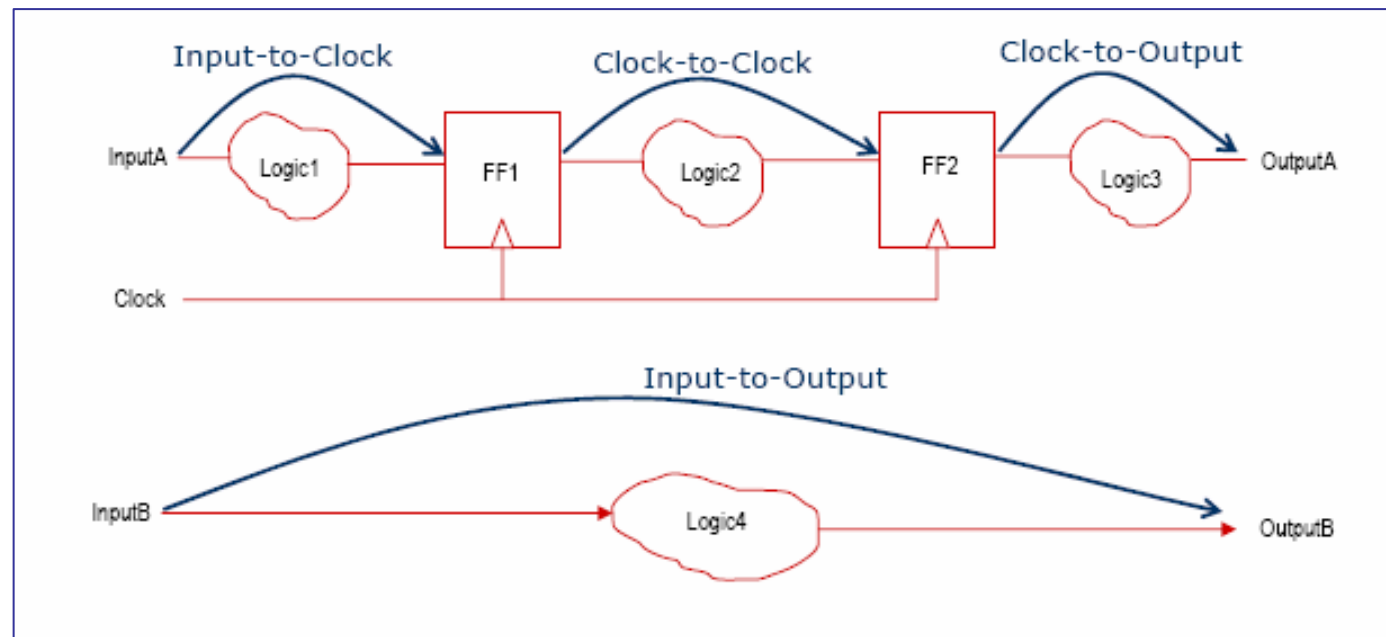

Flip-Flop Timing

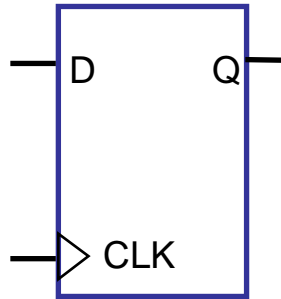

```
INFER: process (CLK) begin
  if (CLK'event and CLK = '1') then
    Q <= D;
  end if ;
end process INFER;
```

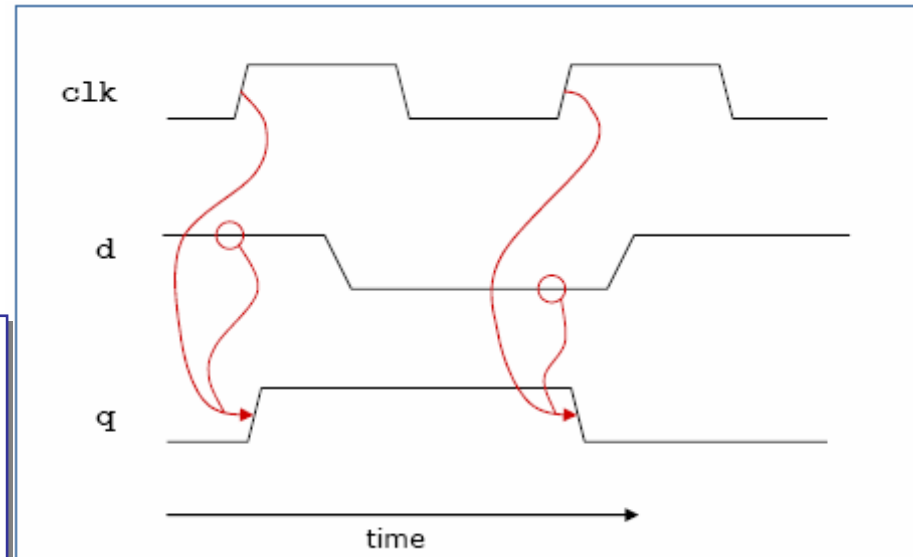

- The level of d is sampled on the rising edge of clk
- q holds the sampled value until the next clk rising edge
- The level of d must be stable for some amount of time before and after the sampling clock edge

Flip-Flop Timing Parameters

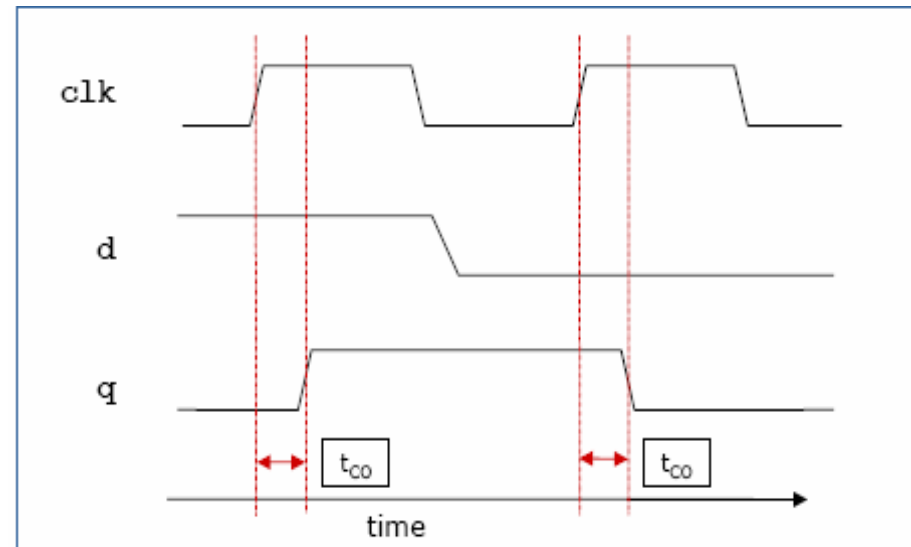
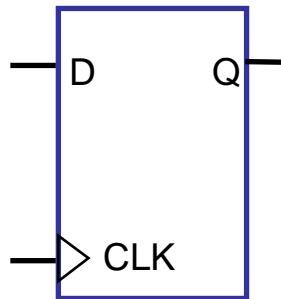

- Clock-to-out (t_{co}) a.k.a. Clock-to-Q
 - The time delay from the active edge of the flip-flop's clock input to the resulting change in the Q output
- Specified minimum and maximum times



Flip-Flop Timing Parameters (cont'd)

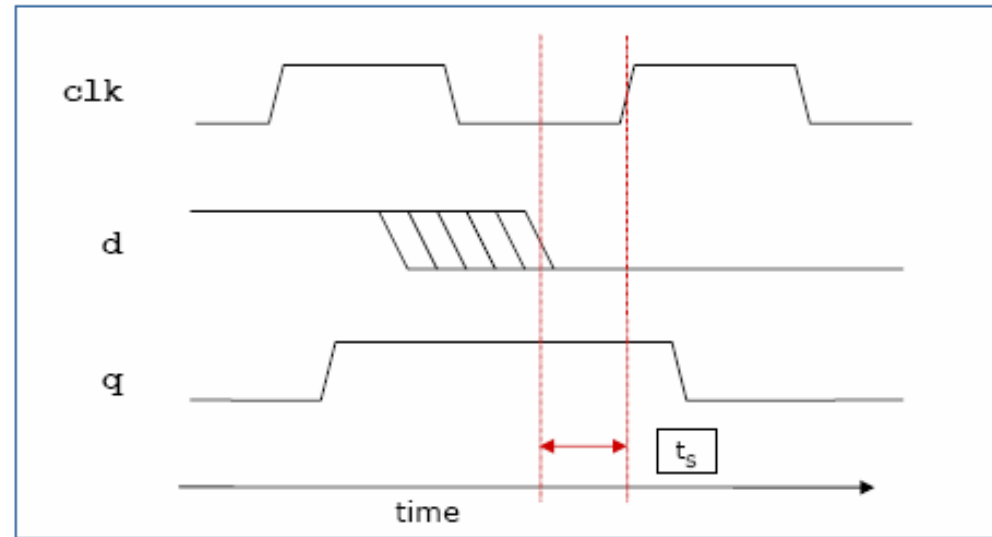
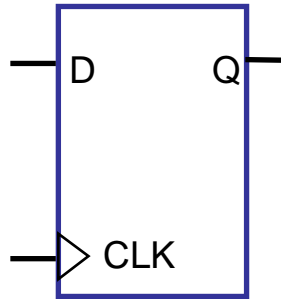

■ Input Setup (t_s)

- The minimum time that the D input must be stable before the active (rising or falling) edge of the clock



Flip-Flop Timing Parameters (cont'd)

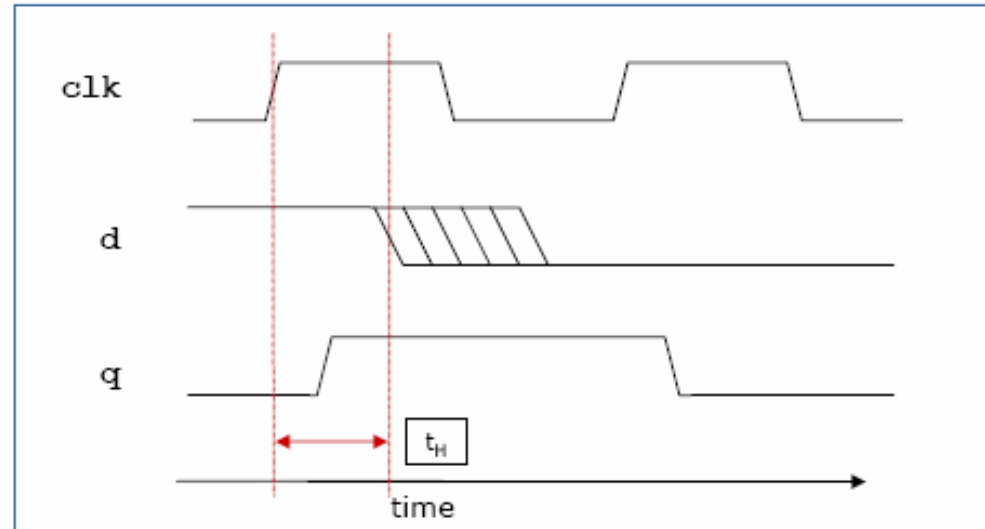
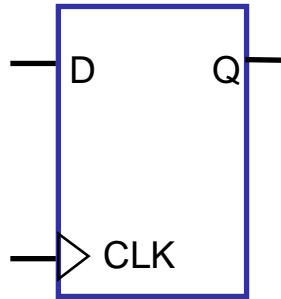

■ Input Hold (t_H)

- The minimum time that the D input must be stable after the active edge of the clock



Flip-Flop Timing Parameters (cont'd)

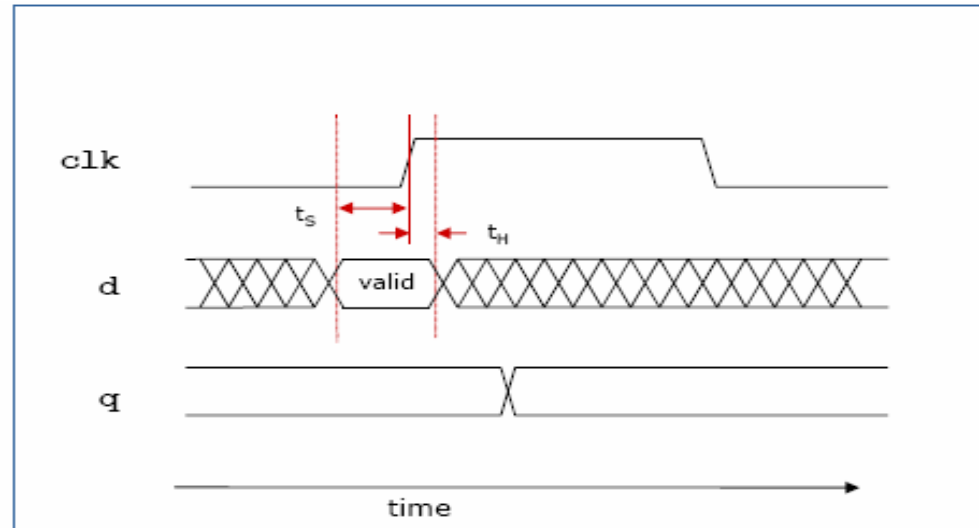
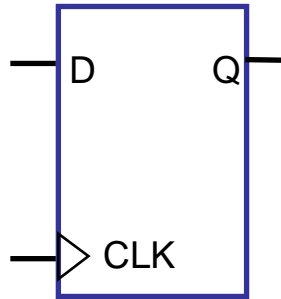

- Setup and Hold define a minimum window around the active clock edge during which D must be stable
- t_s or t_H may be negative, but $t_s + t_H > 0$



Flip-Flop Timing Parameters (cont'd)

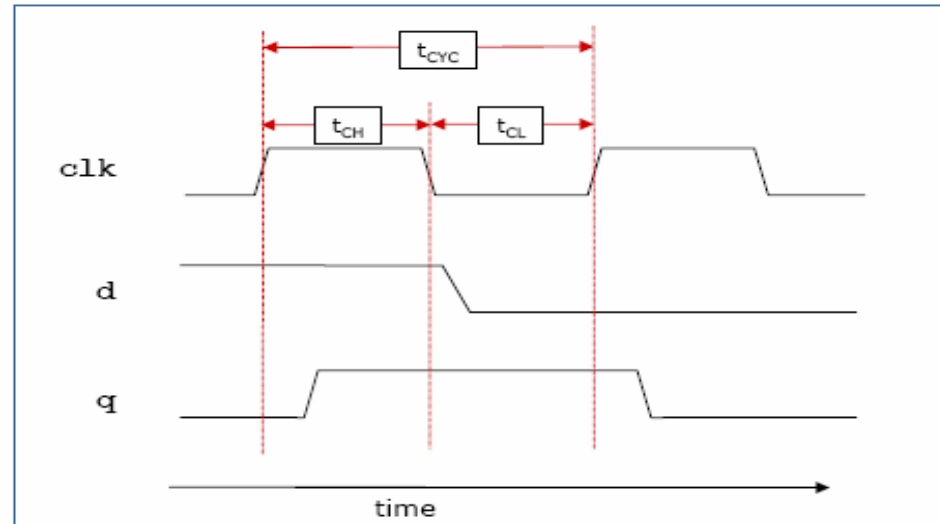
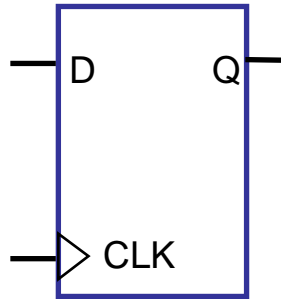

■ Clock Parameters

- **Clock cycle time (t_{CYC}), minimum**
- **Clock pulse width high (t_{CH}), minimum**
- **Clock pulse width low (t_{CL}), minimum**



■ Constraining FPGA Designs with SDC

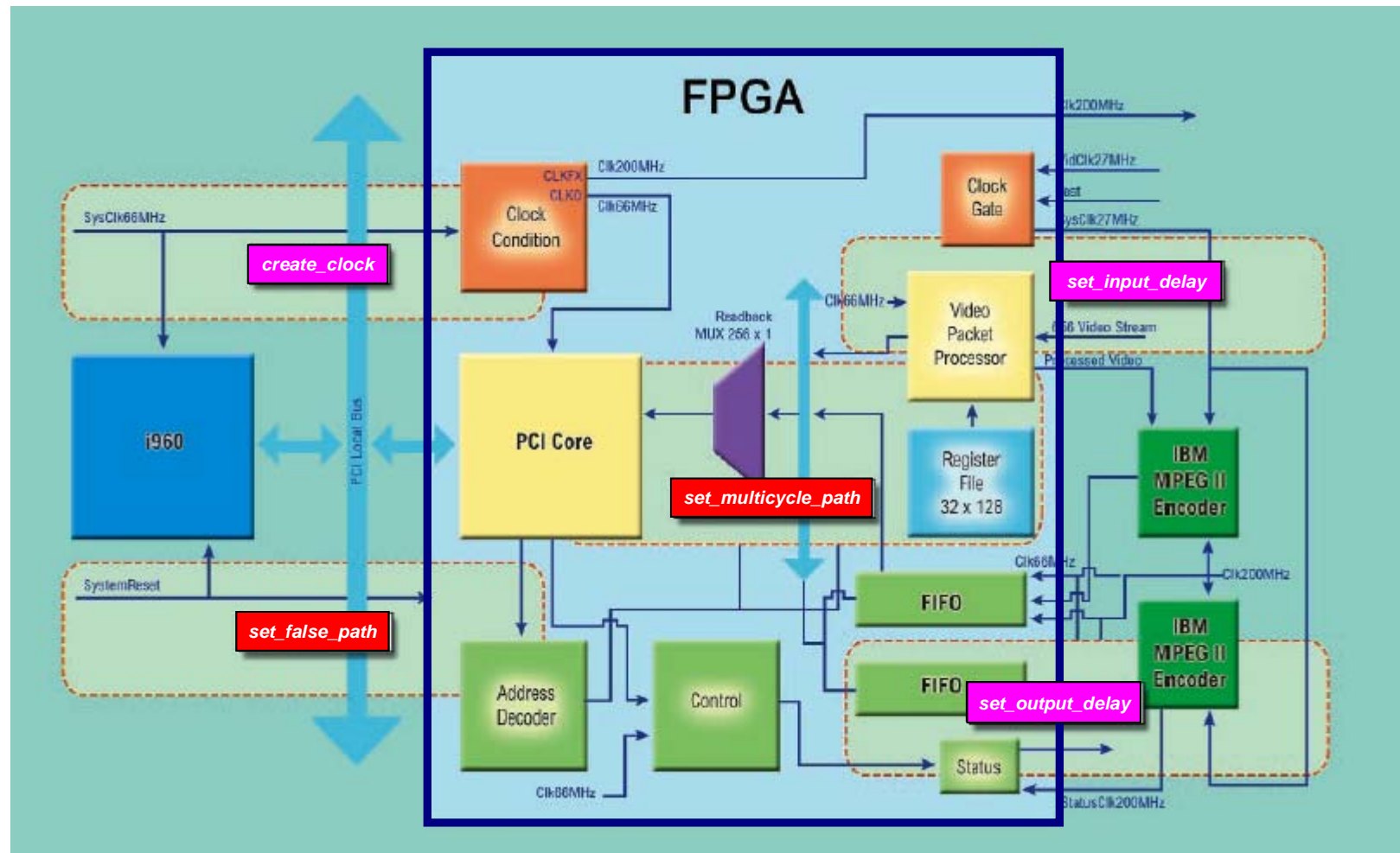

Source: Mentor Graphics Corporation ©, 2002

■ Design Environment

- **Operating conditions (Process / Voltage / Temperature)**
 - ◆ **Worst: to fix the setup violations**
 - ◆ **Typical: mostly ignored**
 - ◆ **Best: to fix the hold violations**

■ Timing Assertions (Design-level)

- **Clock Characteristics**
- **Arrival Time at Each Input Port**
- **Required Time at Each Output Port**

■ Timing Exceptions

- **False Paths**
- **Maximum Path Delay**
- **Minimum Path Delay**
- **Multi-cycle Paths**



Timing Analysis: Setup/Hold Check



- Create Clock: reg-to-reg requirement

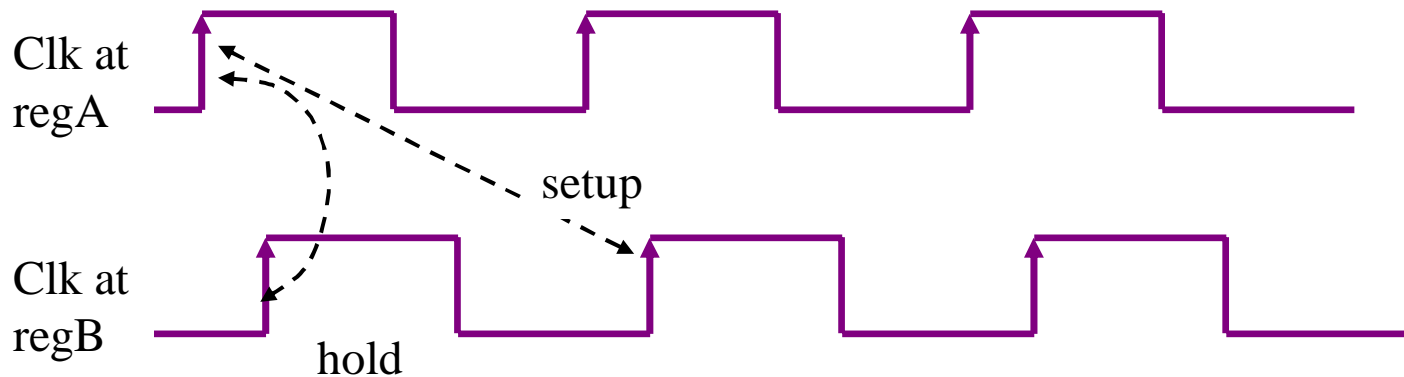
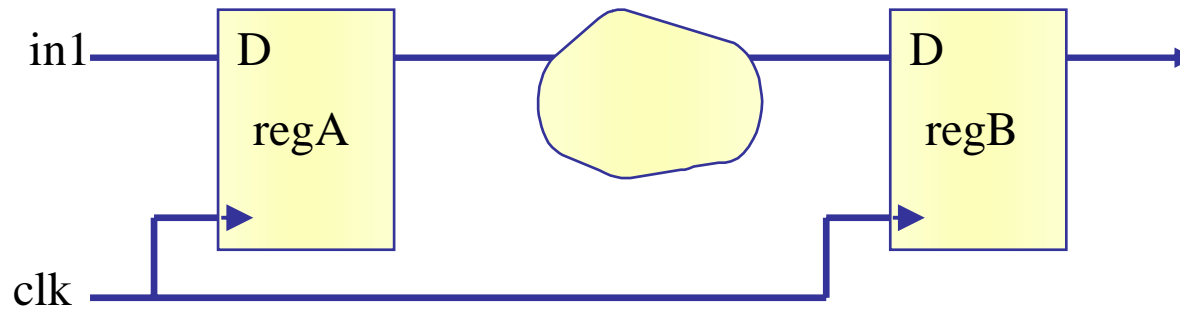

Single-cycle timing relationship



Setup Check

■ Arrival/Required

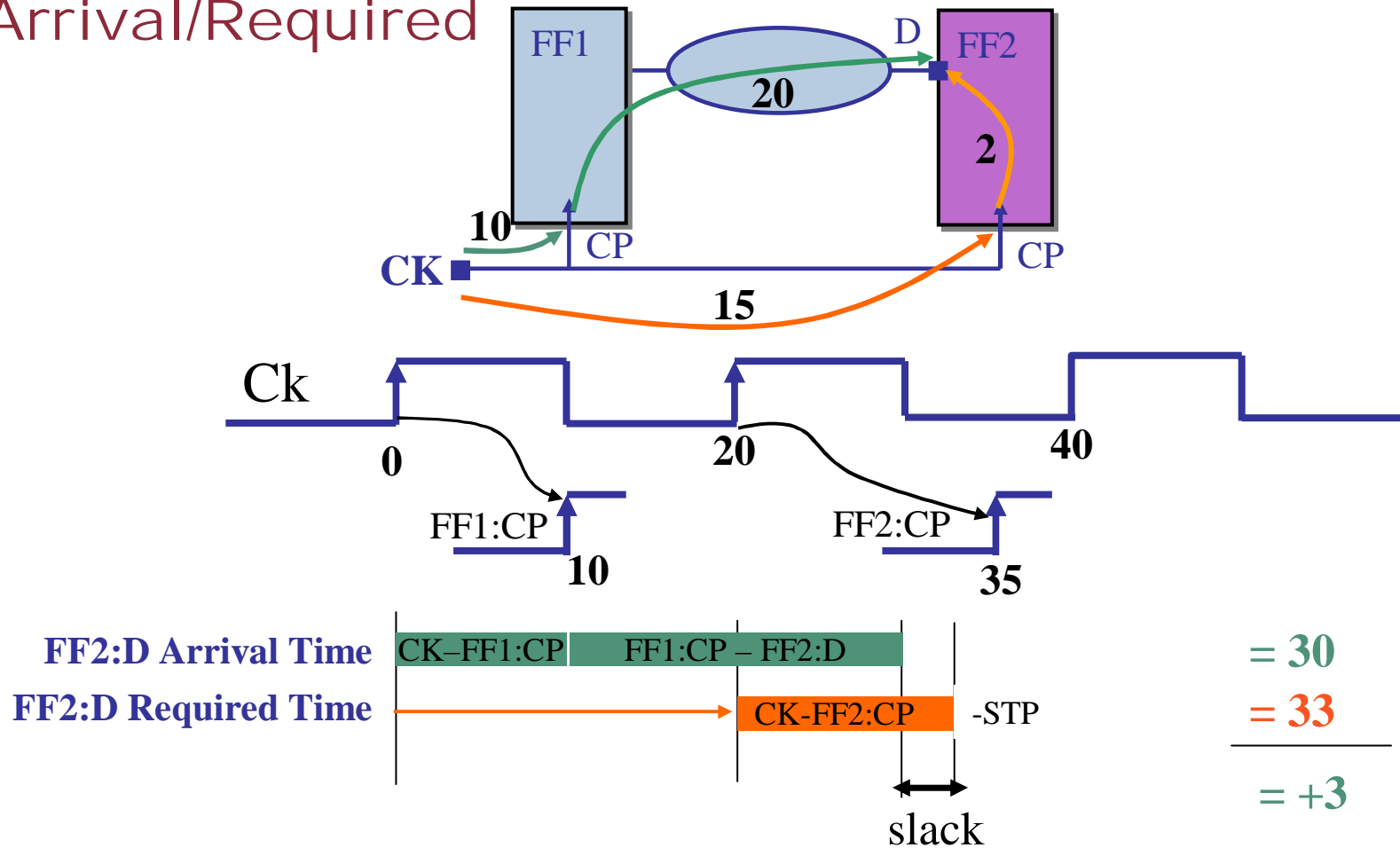

Slack = Required_time – Arrival_time (Violation if < 0)



Hold Check

■ Arrival/Required

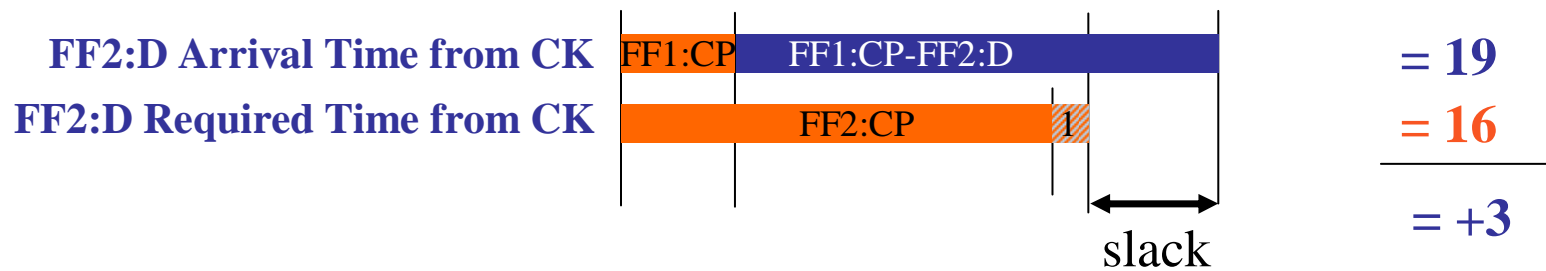
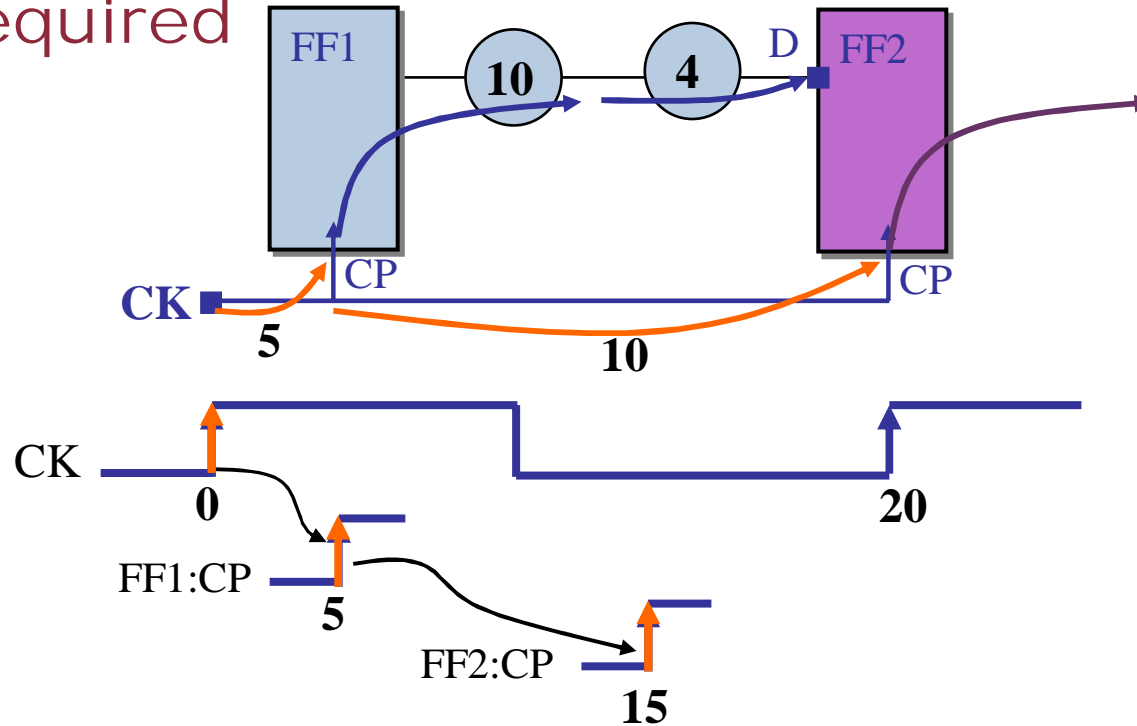

Slack = ArrivalTime – RequiredTime (Violation if < 0)



Timing Analysis: Multi-cycle

- `set_multicycle_path`: reg-to-reg exception

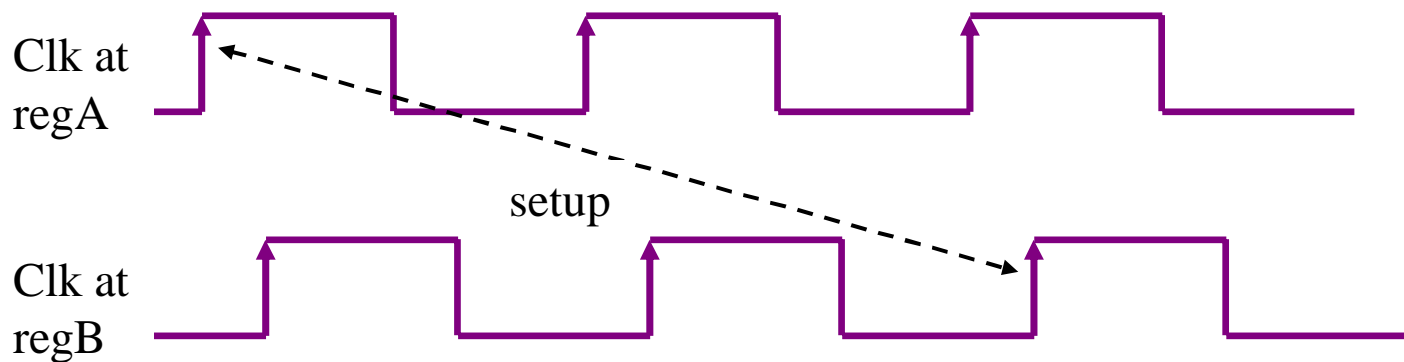
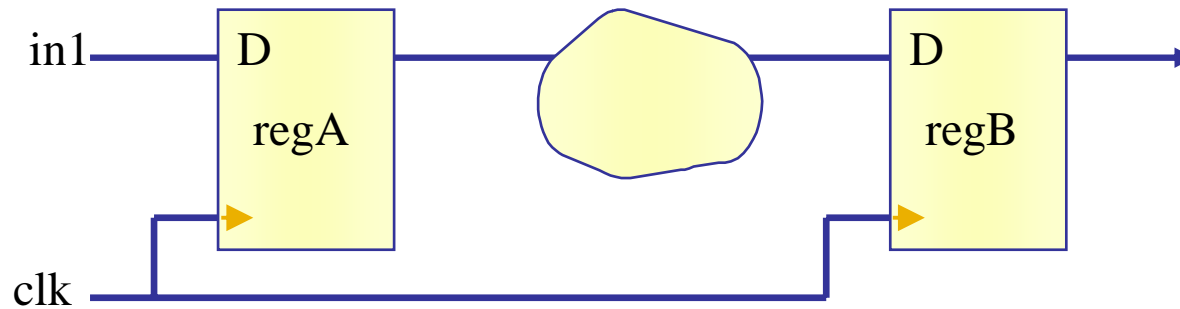

multi-cycle timing relationship

Input Delay Constraints

- Captures External Setup/Hold Requirements

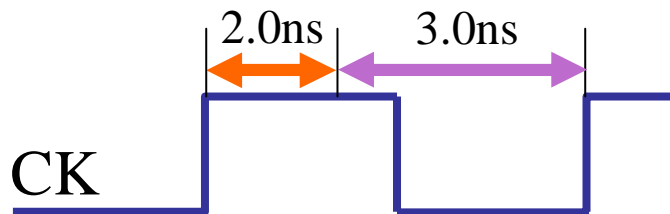
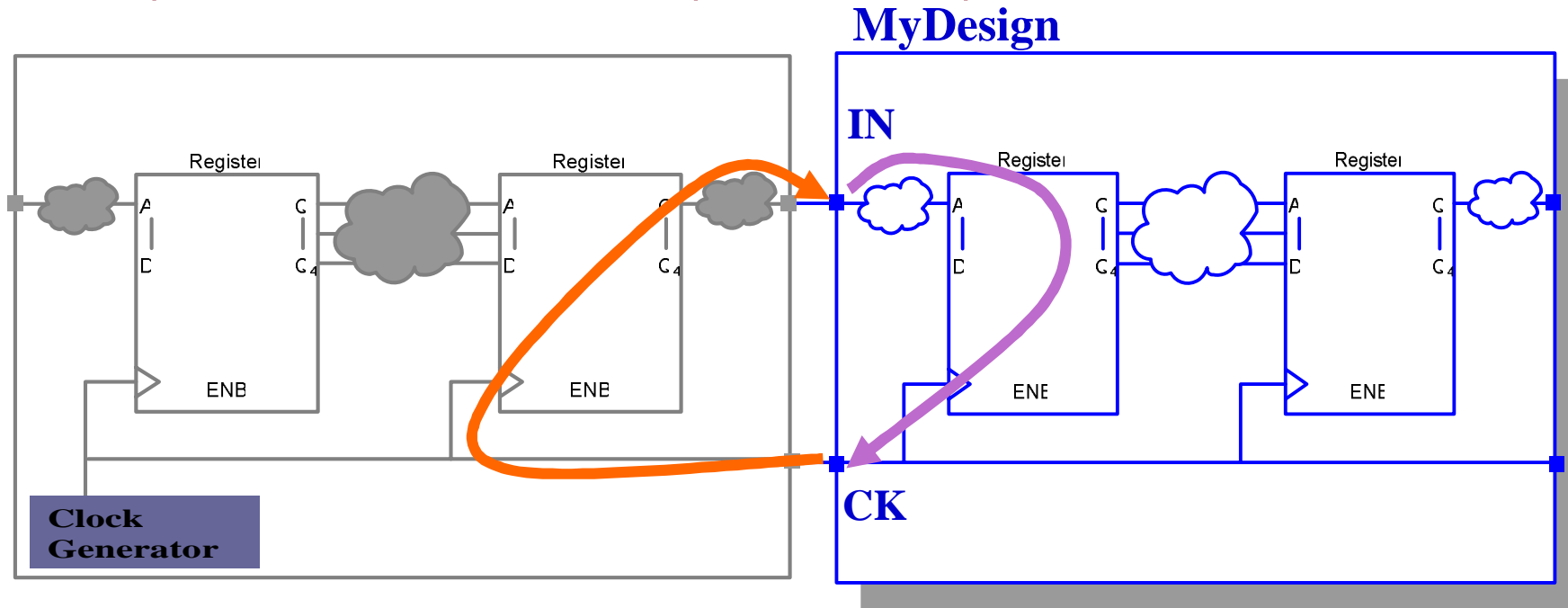

Option “-min” for hold check
Option “-max” for setup check

```
SDC: set_input_delay 2.0 -clock CK {IN}
```



- Set Input Delay: setup/hold requirements

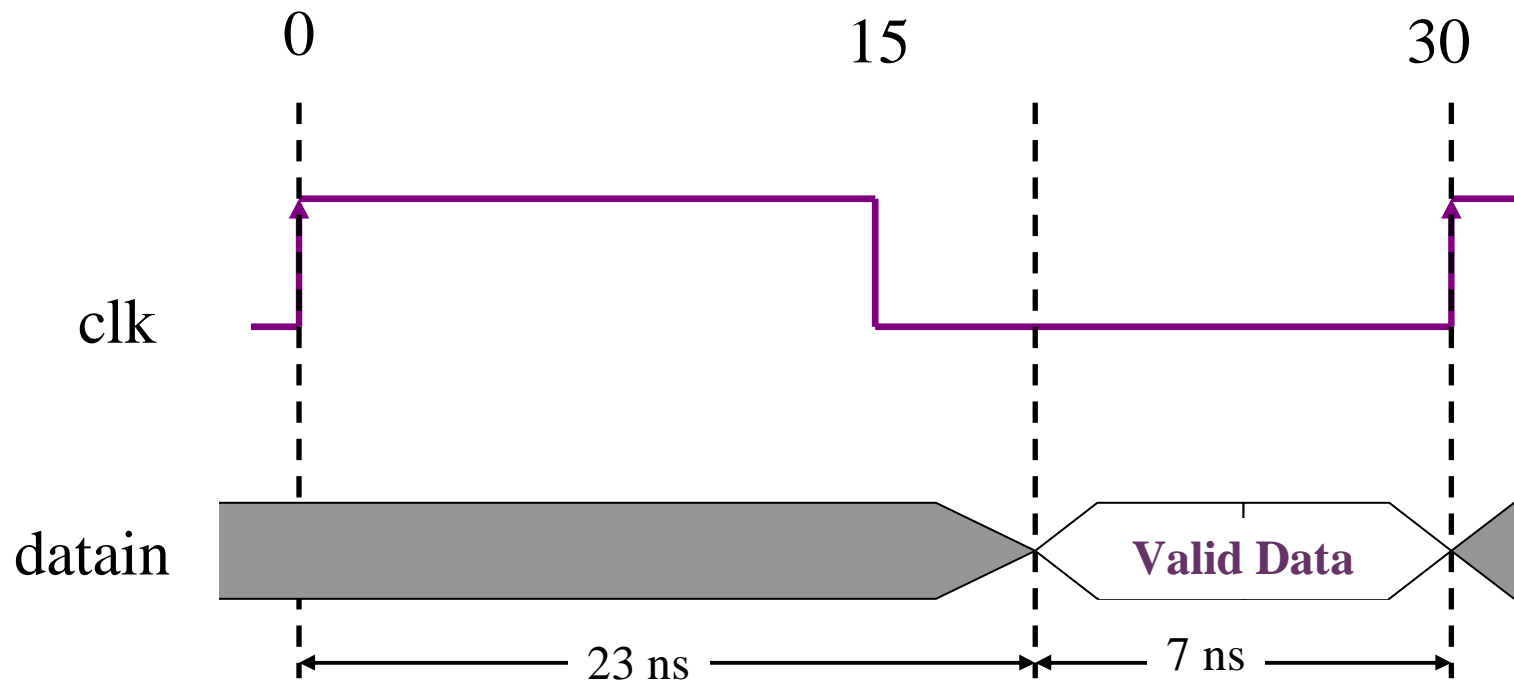

```
> set_input_delay -max 23.0 -min 0.0 -clock clk {datain}
```



Output Delay Constraint

- Captures Clock-to-Out Requirements

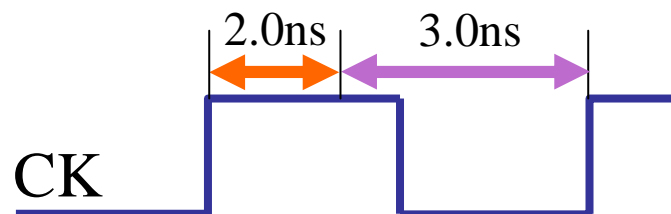
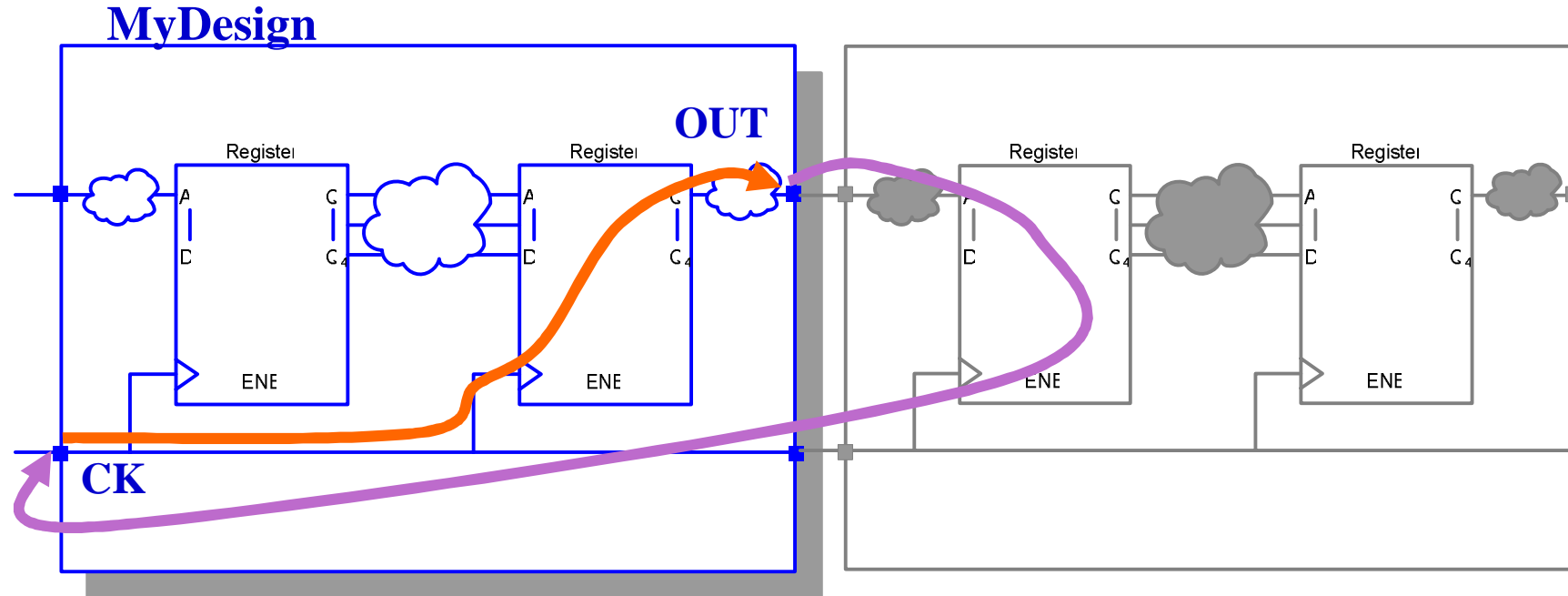

Option “-min” for hold check
Option “-max” for setup check

```
SDC: set_output_delay 3.0 -clock CK {OUT}
```



- Set Output Delay: clock-to-out requirement

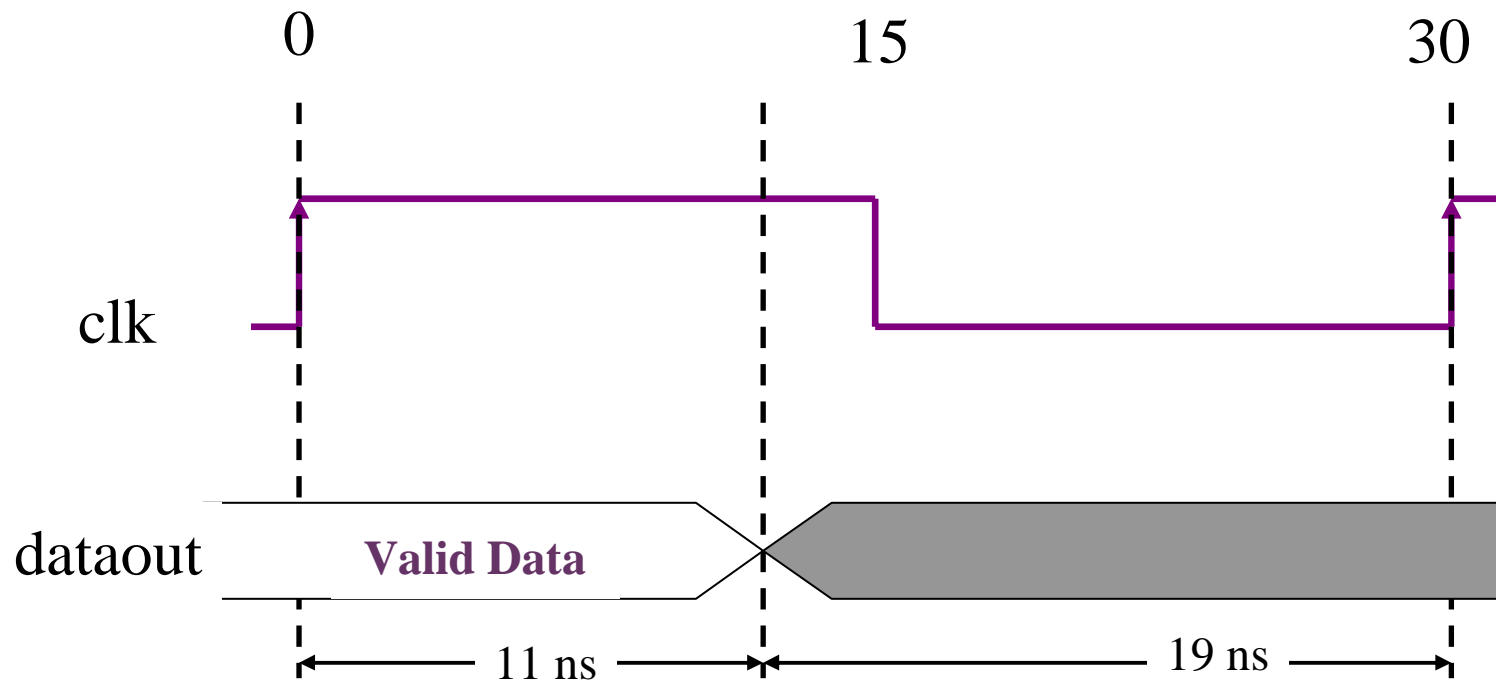

```
> set_output_delay -max 19.0 -clock clk {dataout}
```



■ Study over the Least Common Multiplier

common
period

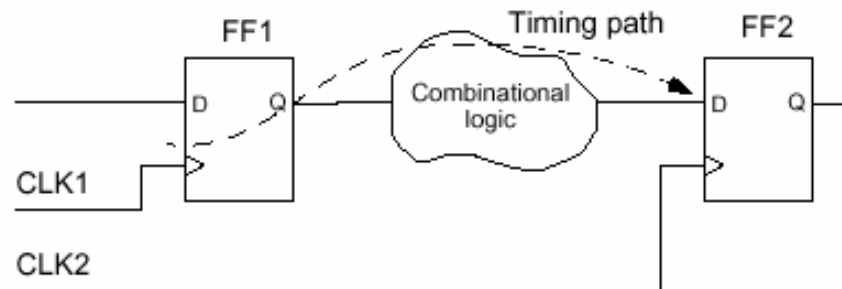

```
pt_shell> create_clock -period 20 -waveform {0 10} CLK1
pt_shell> create_clock -period 10 -waveform {0 5} CLK2
```

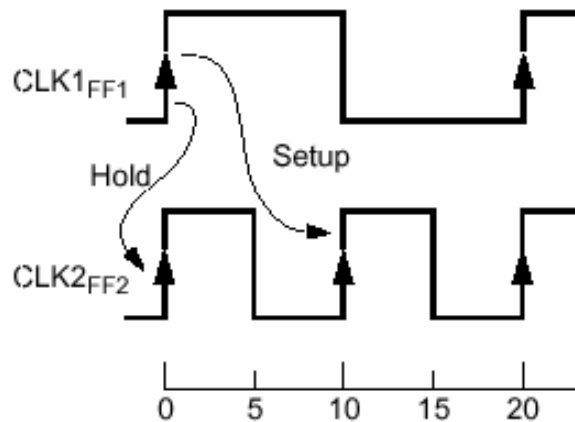

Design Overview Block Diagram

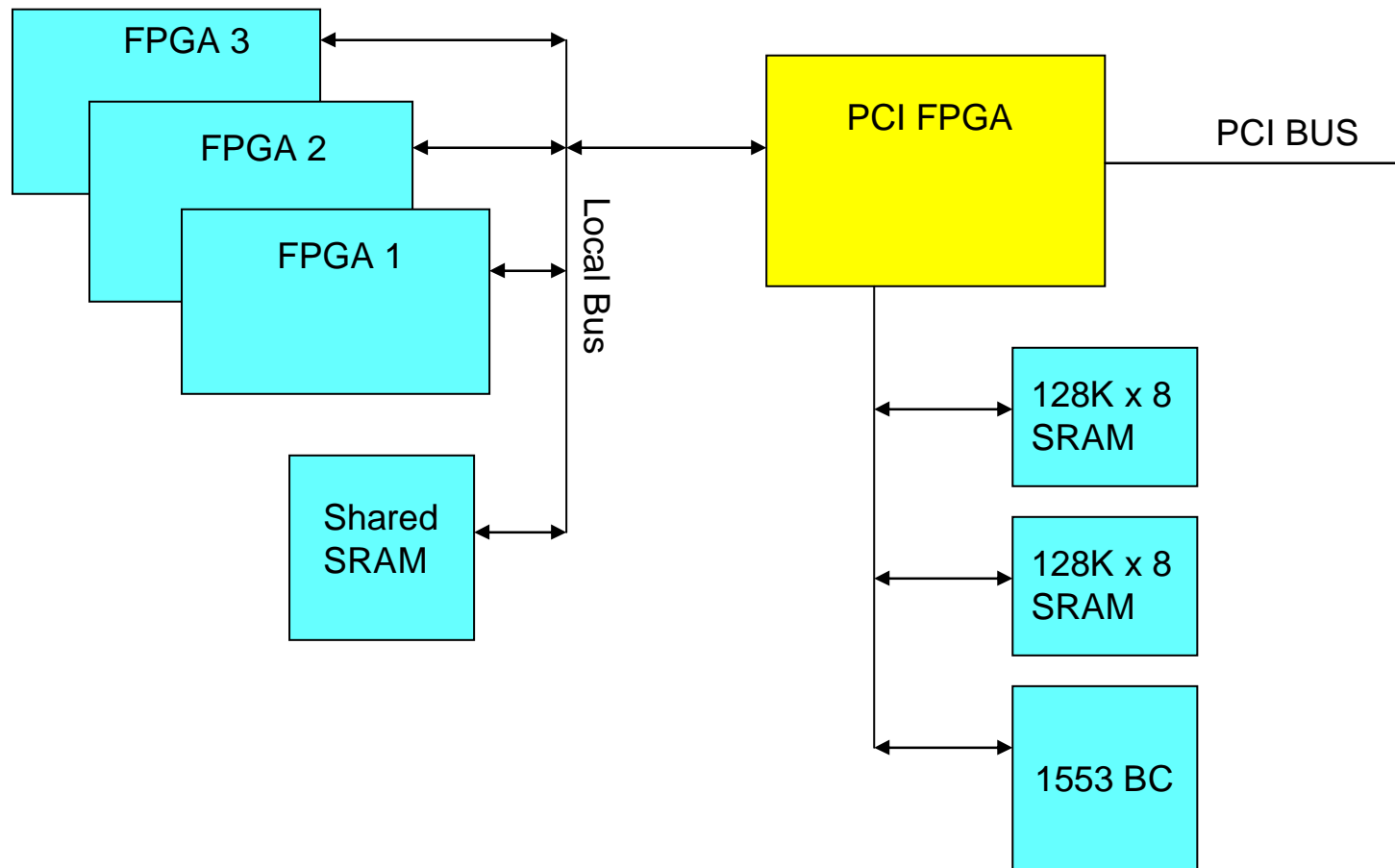

Design Overview System Timing Requirements



■ PCI

- 33 MHz Clock
- External set up time – 7 ns
- Clock to output – 10 ns

■ Local Bus

- 24 MHz Clock
- I/O is asynchronous

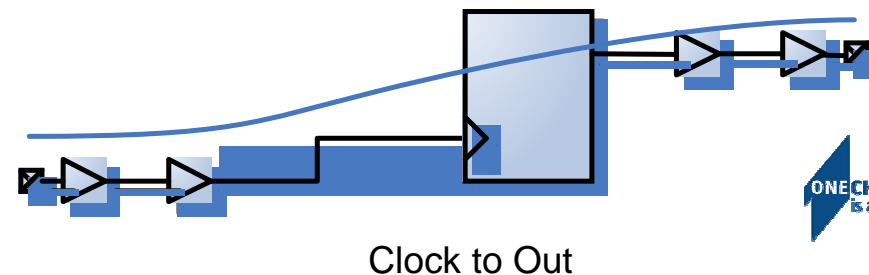
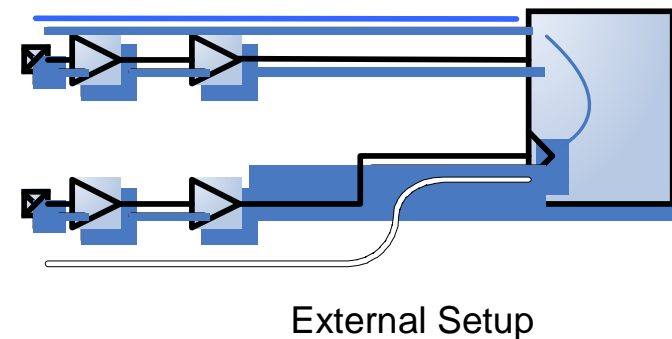
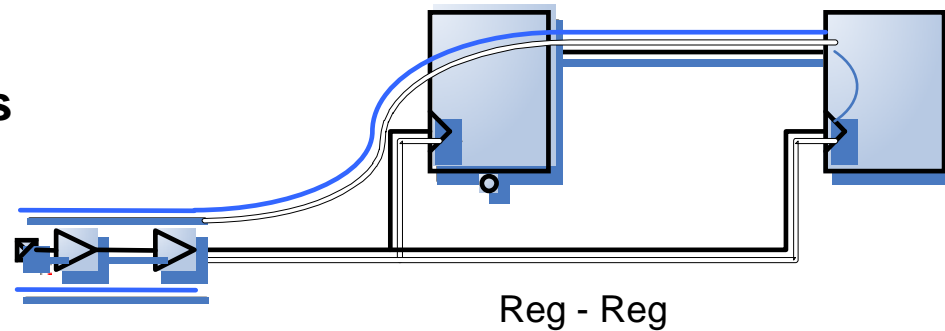

Design Overview Timing Closure Loop

