



**The Abdus Salam
International Centre for Theoretical Physics**



2166-Handouts

**College on Medical Physics. Digital Imaging Science and Technology to
Enhance Healthcare in the Developing Countries**

13 September - 1 October, 2010

X-ray Tube and Generator - Basic principles and construction

Slavik Tabakov
*King's College London
United Kingdom*

X-ray Tube and Generator – Basic principles and construction

Dr Slavik Tabakov
King's College London

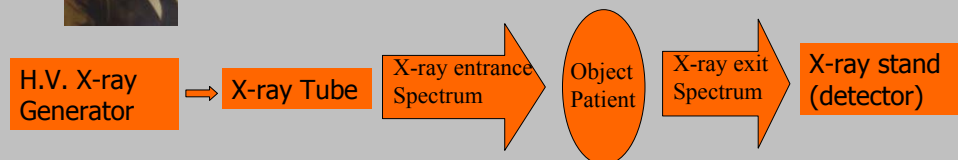

- Production of X-rays
 - X-ray tube construction
 - Anode - types, efficiency
 - X-ray tube working characteristics
 - Intensity of X-ray beam, housing and filtration
 - Classical X-ray generator (block diagram)
 - Medium frequency X-ray generator (block diagram)
 - Principle of radiographic contrast formation
 - X-ray film and film/screen combination
 - Mammographic contrast and X-ray tubes
 - Various radiographic contrasts (definitions)
- OBJECTIVES**

Table 2. Annual exposure of the UK population from all sources of radiation.

Source	Percentage
Natural	
Radon gas	50
Gamma rays from rocks and soil	14
Radionuclides in food and drink ^a	11.5
Cosmic rays	10
Artificial	
Medical x-rays	13
Nuclear medicine	1
Occupational ^b	0.3
Fallout from nuclear weapons tests	0.2
Nuclear discharges ^c	<0.1
Consumer products	<0.1

^a Mainly potassium-40.

^b About 80% from natural sources.

^c About 20% from natural activity.



In most industrialised countries there are between 300 and 900 X-ray examinations for every 1000 inhabitants every year. Over half of these are chest examinations (these figures does not include dental X-ray examinations or mass screening programs).

Doses varies widely from hospital to hospital, even in the same country, sometimes by a factor of 100.

Radiation and You, EU, Luxembourg 1990

Approximately 90% of the total collective dose to UK population from man-made radiation sources arises from Diagnostic Radiology

Safety in Diagnostic Radiology, IPEM, 1995

Patient radiation doses from diagnostic radiology, D Hart, 1996

Collective dose to population from Diagnostic Radiology

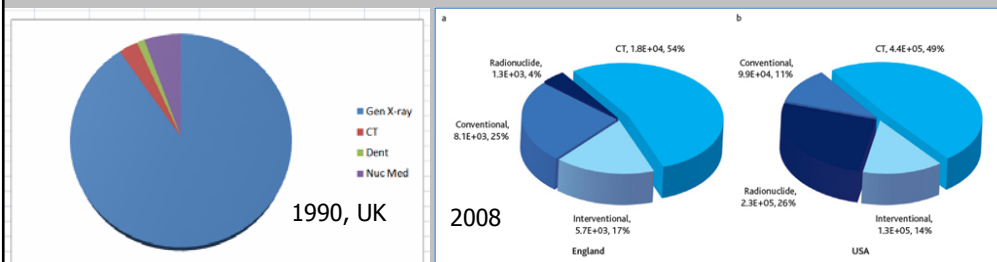

Estimated annual collective dose to UK population from Diagnostic Radiology (approx. figures):

1989 - 17,000 manSv;

1999 - 20,000 manSv (risk estimate approx. 700 cancer deaths/year);

2008 - 25,000 manSv

Safety in Diagnostic Radiology, IPEM, 1995; UK population dose from medical X-ray examinations, D. Hart, B. F. Wall, 2002; Considerations for Radioactive Substances Regulation under the Radioactive Substances Act 1993 at nuclear sites in England and Wales, 2008

Distribution of X-ray dose from the Tube through the Patient to the X-ray film

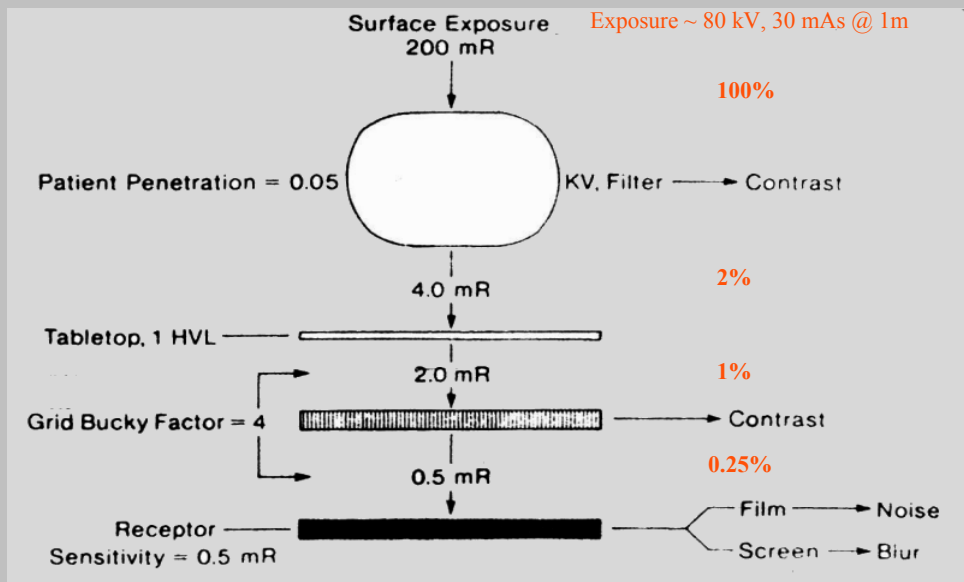

(a)

(b)

Energy flux

Unfiltered

Photon energy →

Maximum energy

Production of X-rays and Bremsstrahlung (stopping radiation) – thermal electron emission in vacuum (10^{-6} mbar) and target bombardment

White X-ray spectrum (gamma quanta with all energies) and its final view (after tube filtration)

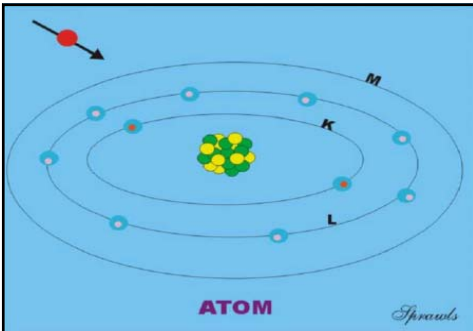

ATOM
Sprauls

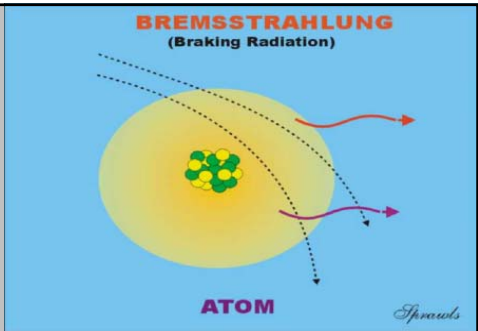

**BREMSSSTRAHLUNG
(Braking Radiation)**

ATOM
Sprauls

Imaginary model	Real (approximate)	Scaled-up approx. model (linear)	Volume ratio: e vs A $\sim 10^{15}$
Electron radius	10^{-15} m	1 mm	
Nucleus radius	10^{-14} m	10 mm	
Atom radius	10^{-10} m	100 000 mm (100 m)	
Inter-atom dist in crystal	10^{-10} m	100 m	

Richardson equation:
 $J_0 = A_0 \cdot T^2 \cdot e^{-w/kT}$, where

J_0 - density of the emission current ;
 T - temperature of the emitter (in K);
 k and w - constants (k -Boltzmann constant,
 w - work function, for $W = 4.5$ eV)
 A_0 - constant depending of the material of
 the emitter (for $W = 60$ A.cm⁻²K⁻²)

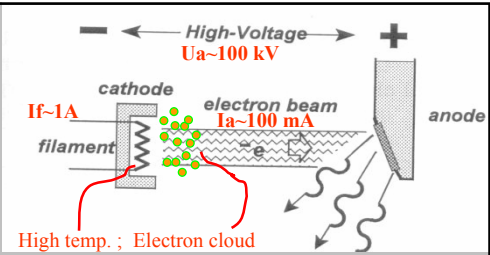

Space charge effect - X-ray tube function characteristics

PRE-Heating of Cathode

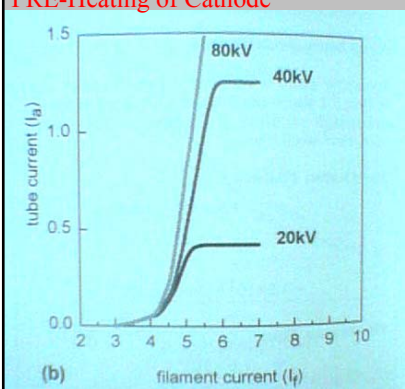

(b)

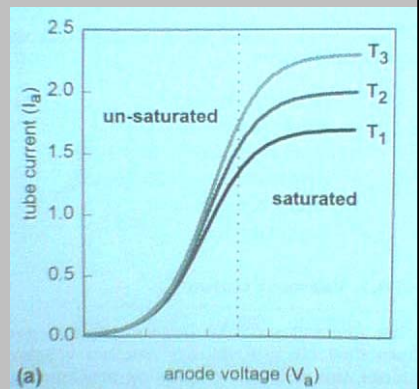

(a)

Cathode – W wire filament (~10x0.2 mm)
 Anode – W plate (melting at 3370°C)
 Construction: stationary and rotation

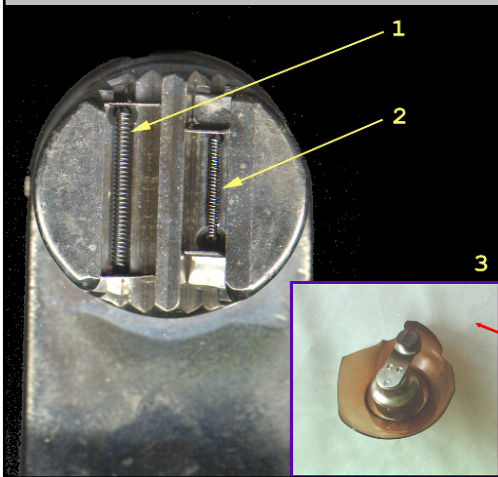

Cathode assembly
 (inside broken Tube)

Melted tungsten
 at anode target

ANODE: X-ray tube focal spot -
 Line focus principle

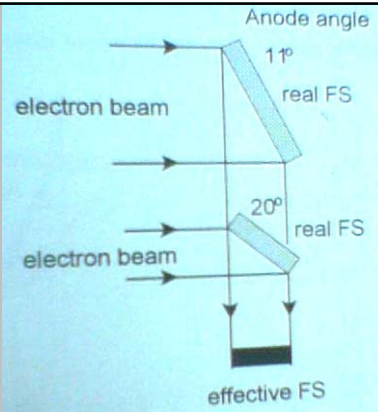
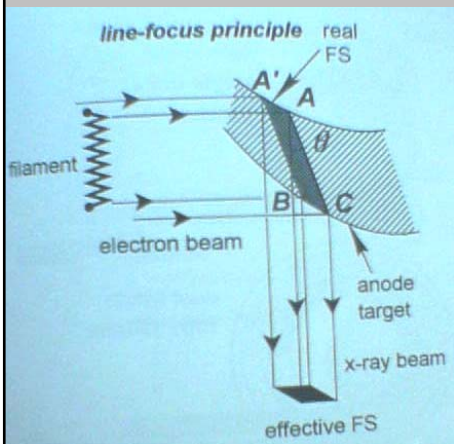

Dual
 focus
 X-ray
 tube

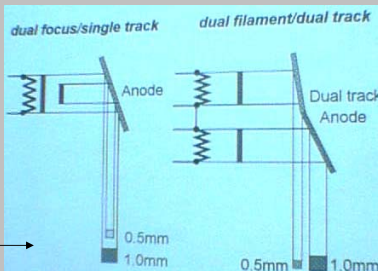

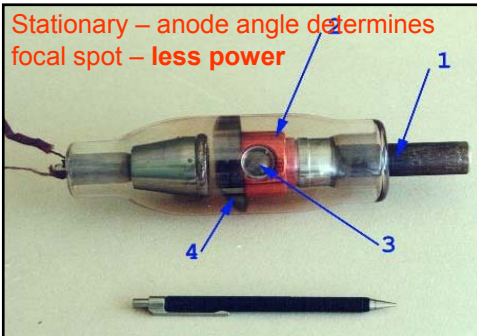

Anode angle: $EF = \sin \alpha \cdot AF$

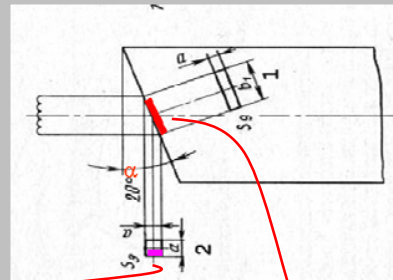

Effective focus - EF ; Thermal (Actual) focus - AF

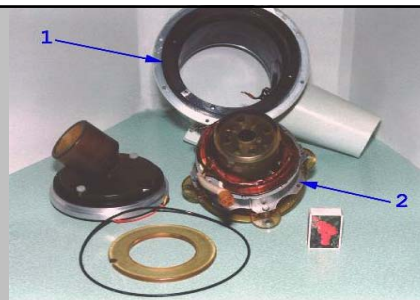
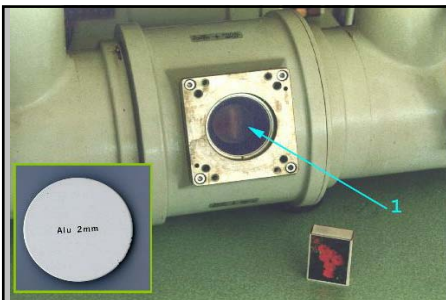
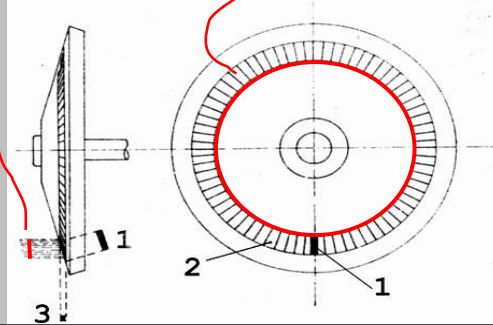

X-ray Tube Housing – Insulating Oil; Output window; Pb lining; Leakage radiation

Tube leakage radiation measurement

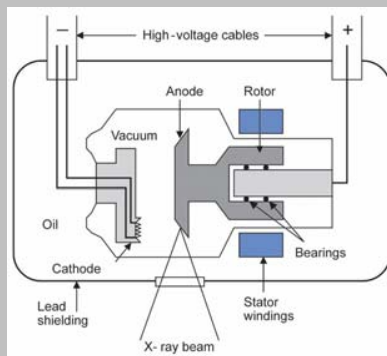

Tube and Housing cooling & T° protection



Metal X-ray tube with liquid metal bearing ('aqua planning' groove)

Anode heat - storage and dissipation (cooling)

$$P_{\max} \sim f^{3/2} \cdot D^{1/2} \cdot n^{1/2} / \sin \alpha$$

The maximal power of the rotating anode (P_{\max}) depends from the effective focal spot size (f); the diameter of the target track (D); the angle of the anode (α); and the speed of rotation (n - r.p.m.):

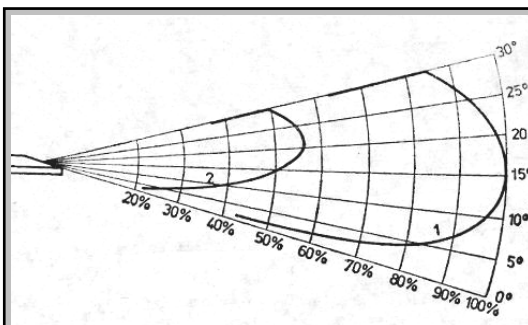

X-ray Intensity distribution:

- In all directions inside the Tube housing (only a fraction of X-rays used – output dose)

- The overall output intensity decreases with ageing of Tube

- Decreased intensity at Anode site (Heel effect) – it is more obvious with old Tubes

Intensity of X-ray radiation : $W \sim I \cdot U^2 \cdot Z$

Anode efficiency $\eta \sim k \cdot U \cdot Z$ (Z -anode atom. No.)

(intensity per energy unit - $\eta = W/I \cdot U$)

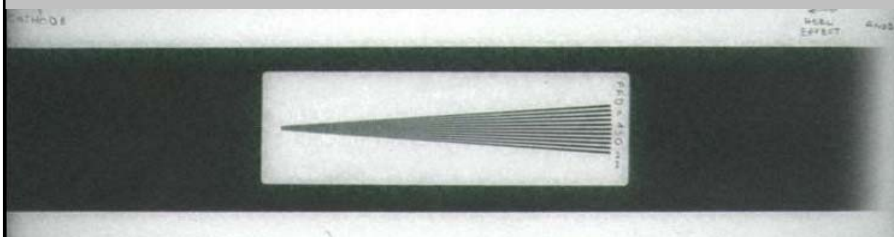

Max. power of the tube:
 $P = kV \cdot mA$ ($100 \times 300 = 30kW$)

Max anode heat capacity
 $HU = kV \cdot mAs$ ($100 \times 1000 = 100kHU$)
 $1HU = 1.4$ Joules

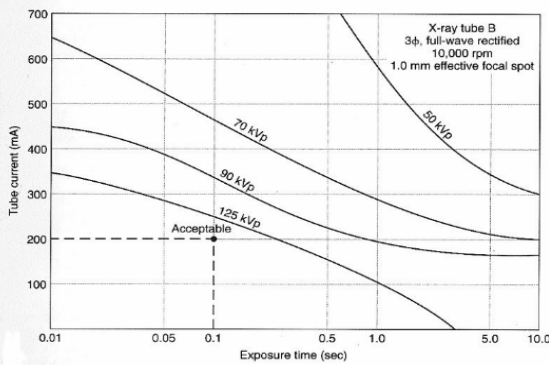
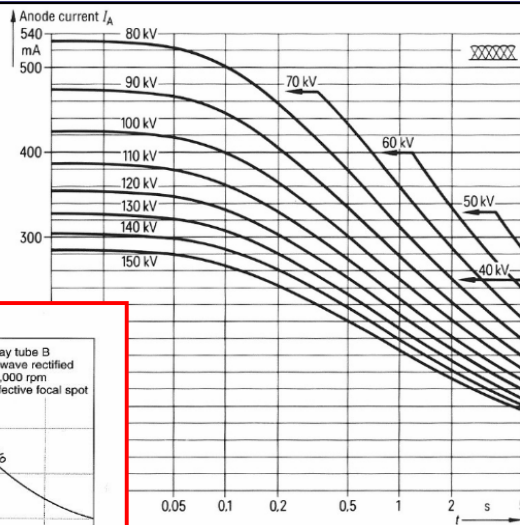

X-ray Tube characteristics:
 Using of single exp. chart

Fine focus and Large focus effects

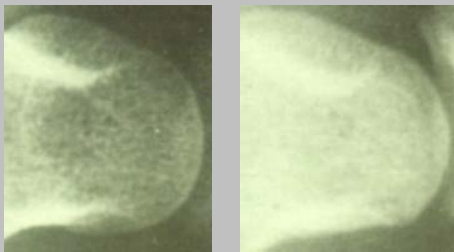
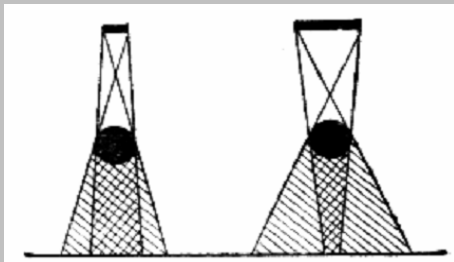

X-ray image resolution depends on the size of the X-ray tube focal spot (effective focus)

Fine (~ 0.5mm) or Broad (~1mm)

The BF smears the contours of the imaged objects (this increases with the increase of object-to-film distance)

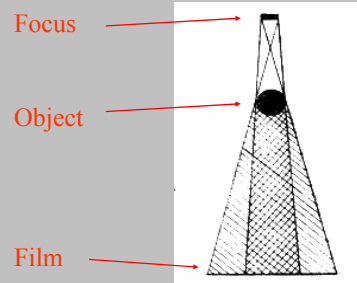

Straton: Revolutionary Tube Technology

The new Straton tube

1. New construction;
2. Focused and deflected beam of thermal e-;
3. The whole tube+anode assembly rotates;
4. Bearings outside
5. Modulated output

THE NEW Straton tube provides direct cooling of the anode with all bearings located outside the vacuum.

Superb e- focusing + heat dissipation (cooling) = small focal spot (better spatial resolution) + high X-ray tube power (penetration & long exposures)

Images from Siemens

X-ray H.V. Generator

- Basic circuits of classical High Voltage X-ray Generator
- kVp waveforms and ripple
- New Medium frequency X-ray Generator
- Basic circuits of medium frequency X-ray Generator
- kVp Control and diagnostic use
- Automatic Exposure Control

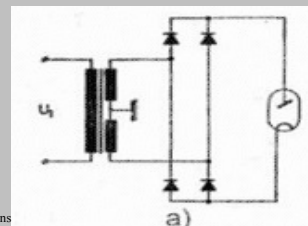

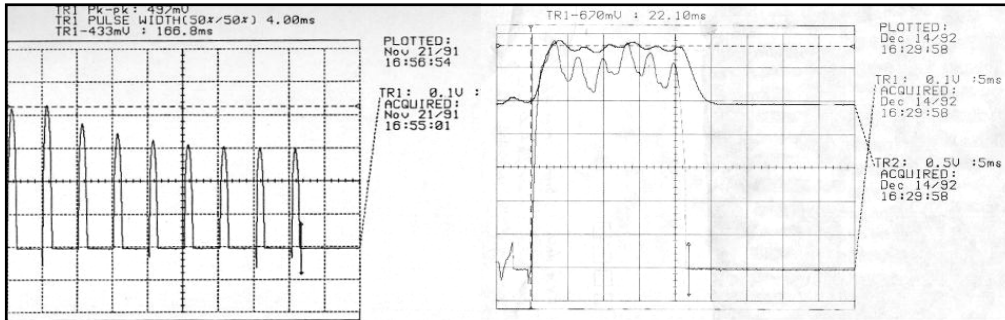

kVp and Dose pulses (waveforms) from various X-ray generators

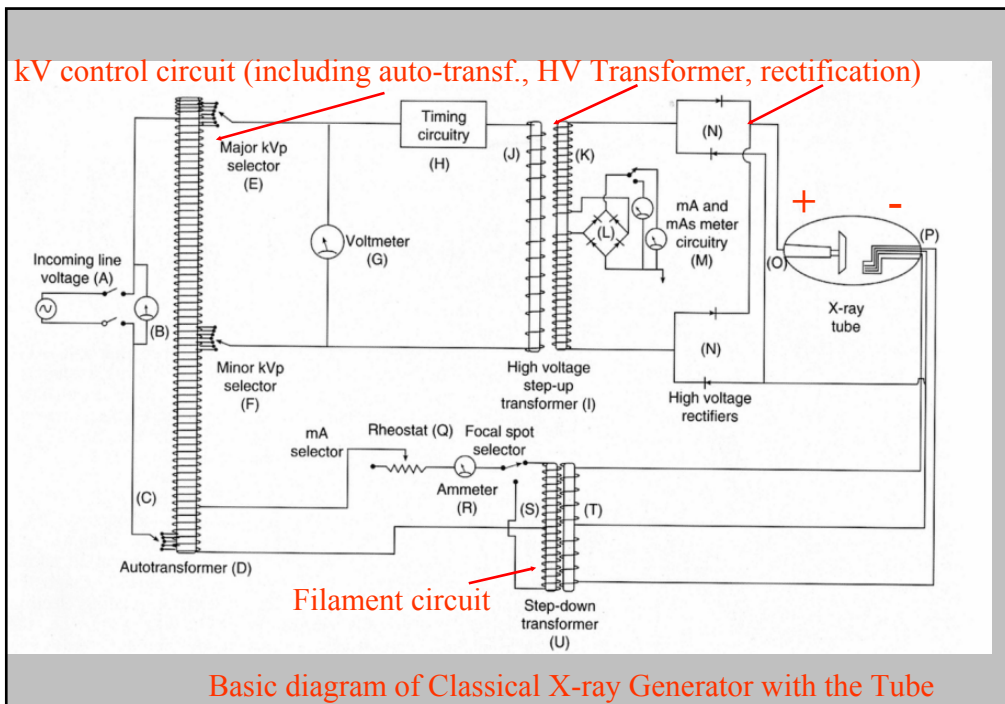
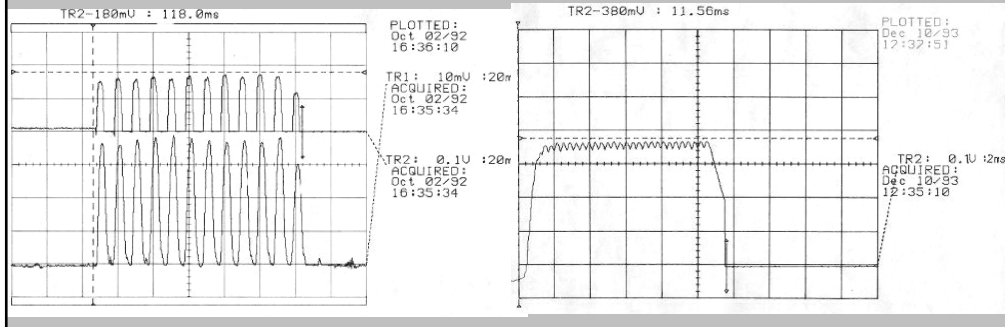

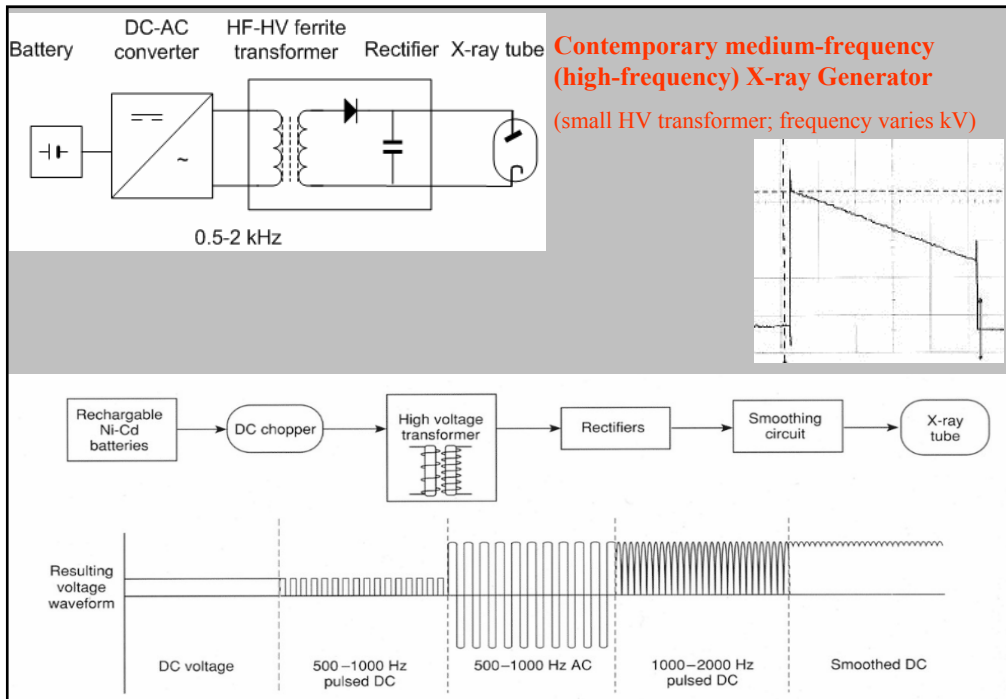

110/120 volts → [primary coil] → [iron core] → [secondary coil] → 220/240 volts

$U / f \sim A \cdot n$

voltage U with frequency f
 A - cross section of the transform core;
 n - number of transformer windings (transformer ratio);

The High Voltage Transformer

$B = \mu H$

magnetic flux density - B (T)
magnetic field strength - H (A/m)
magnetic permeability -
Ferrites - low hysteresis loss, high permeability, work at high frequencies
New High (Medium) Frequency Transformers use 1-20 kHz



$$U / f \sim A . n$$

$A . n$ – is constants for a transformer,

hence $U \sim c.f$

New ferrite core for HV transformer:
(smaller transformer size; electronics;
frequency varies the kV)

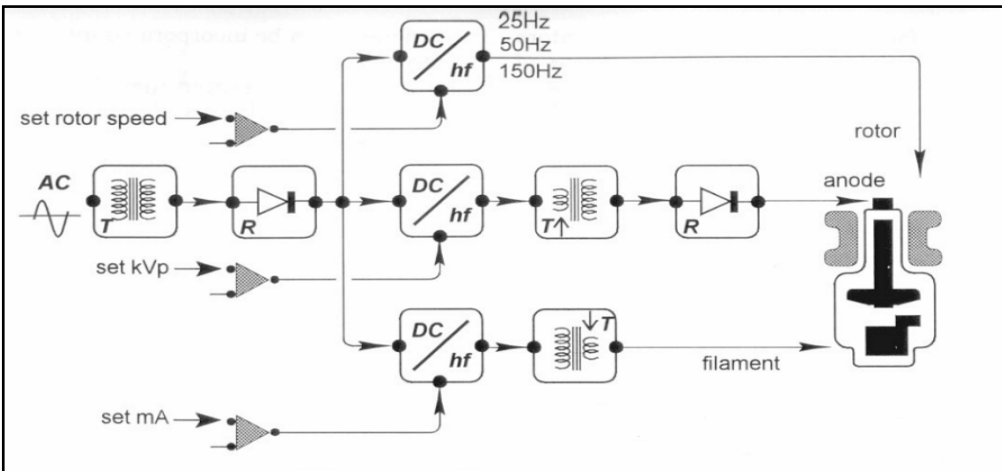
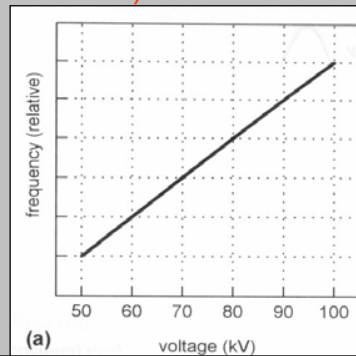

Block-diagram of modern computer-controlled medium frequency X-ray Generator (~20 kHz)

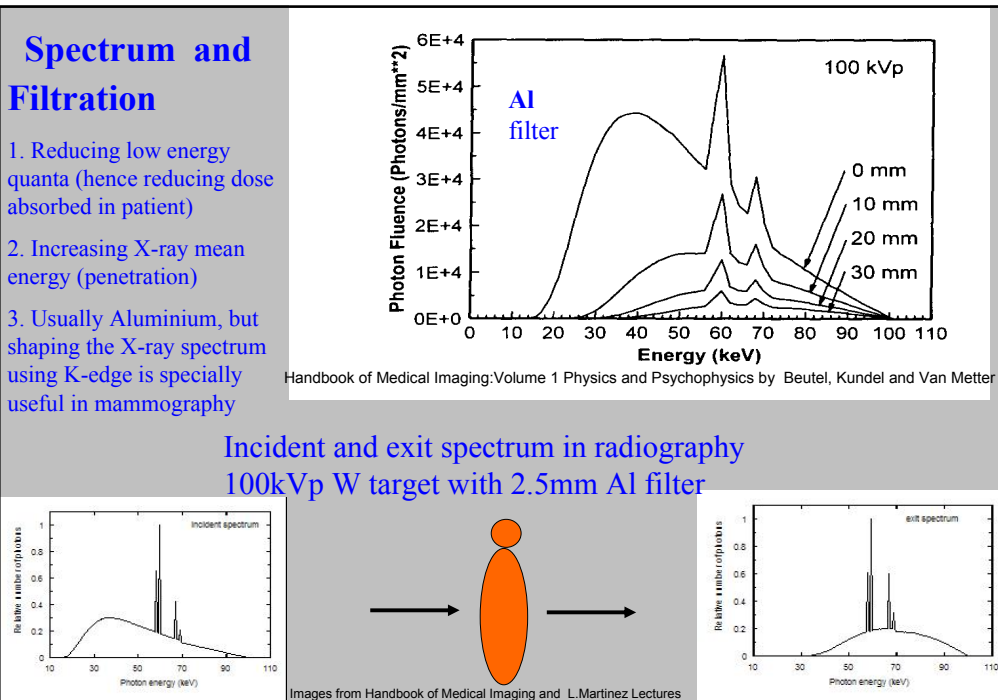
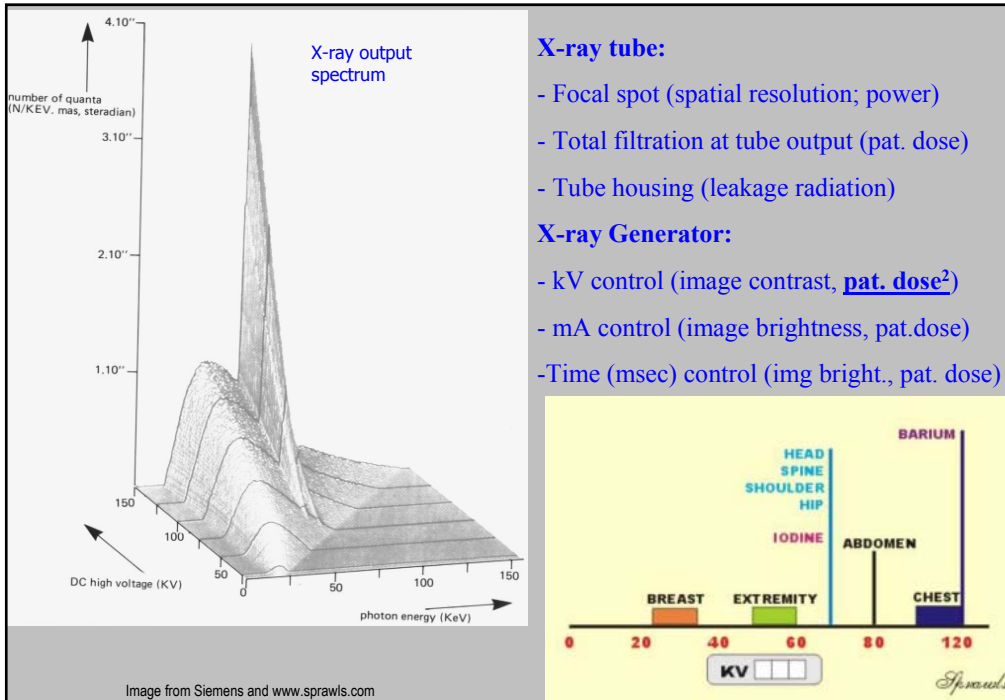

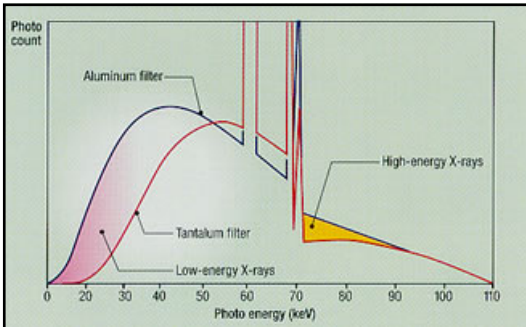

Filtration with use of K-edge

1. Tantalum filter (Toshiba) cuts out the low energy X-ray components and also the high-energy X-ray components that cause scattered radiation. This leads to reduced dose (~30%) and improved signal/noise.

2. Mammo Tungsten anode with Rhodium filter

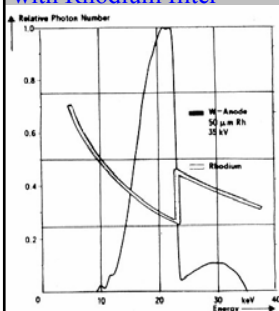

Images from: <http://www.toshibamedical.co.jp/tmd/english/products/xray/cardiovascular/xray5.html> and Tompson, Hattaway, Hall, Dowd "Principles of Imaging Science and Protection"

3. Incident and exit spectrum in mammography 28kVp Mo anode target with 0.03mm Mo filter

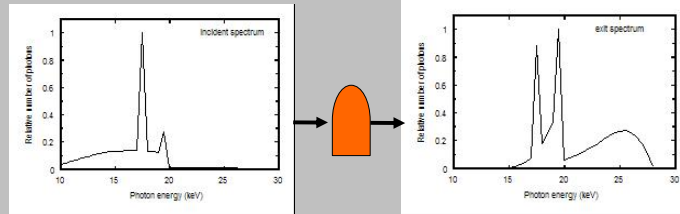

The X-ray source radiation I_0 passes through the object (the body) and is modulated by the body tissues ($\mu \cdot d$) on its way. This modulated radiation beam I_x interacts with the detector, where the modulated radiation is transformed into modulated light – the X-ray image.

The contrast of the image depends on the energy of the X-ray beam.

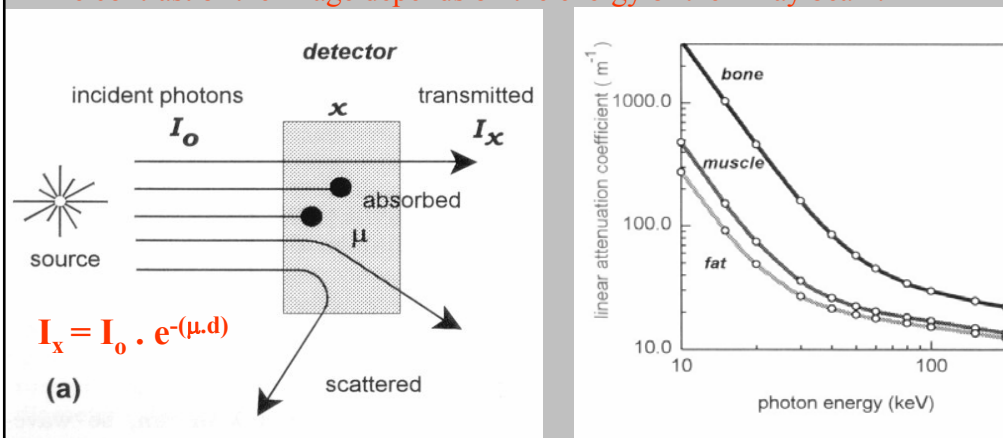

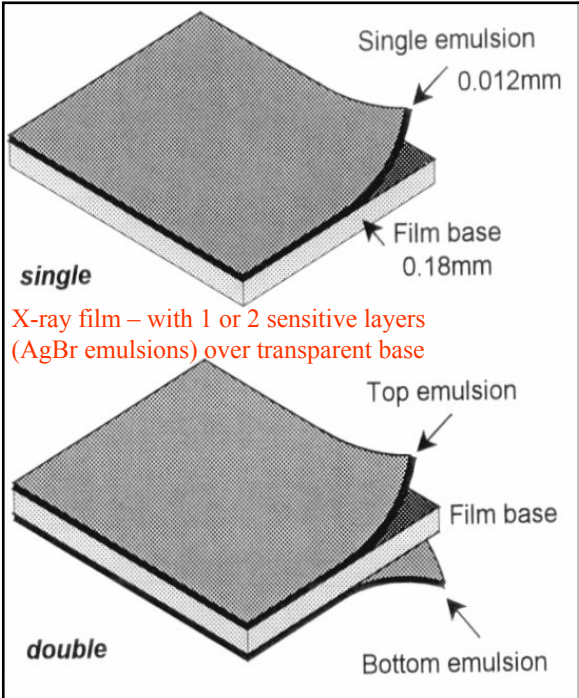

X-ray film – with 1 or 2 sensitive layers (AgBr emulsions) over transparent base

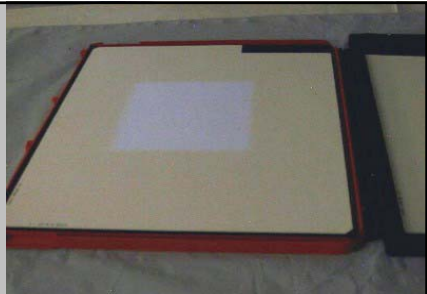

The film is exposed to both X-rays and light inside the cassette

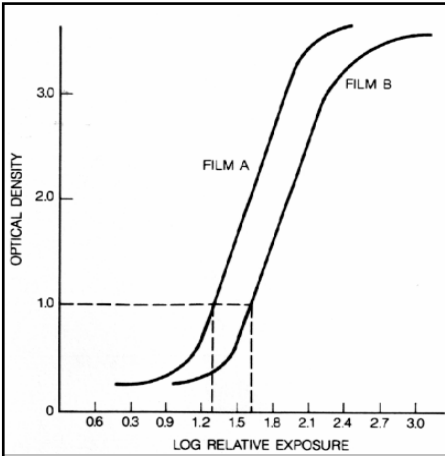

- X-ray film characteristics:
- Exposure latitude (dynamic range);
 - Resolution (grain size)
 - Sensitivity (film speed)

Cassette intensifying screen influence

Development process influence

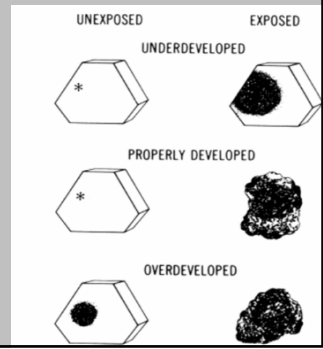
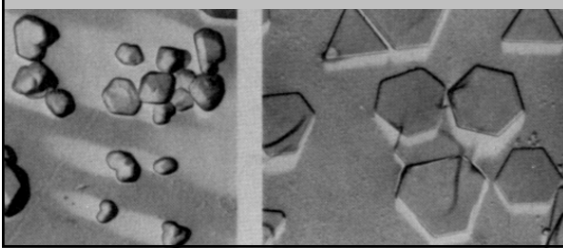

Influence of the characteristic curve

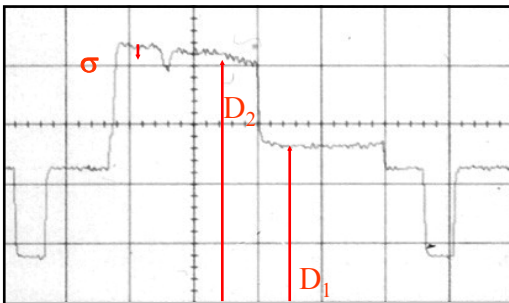
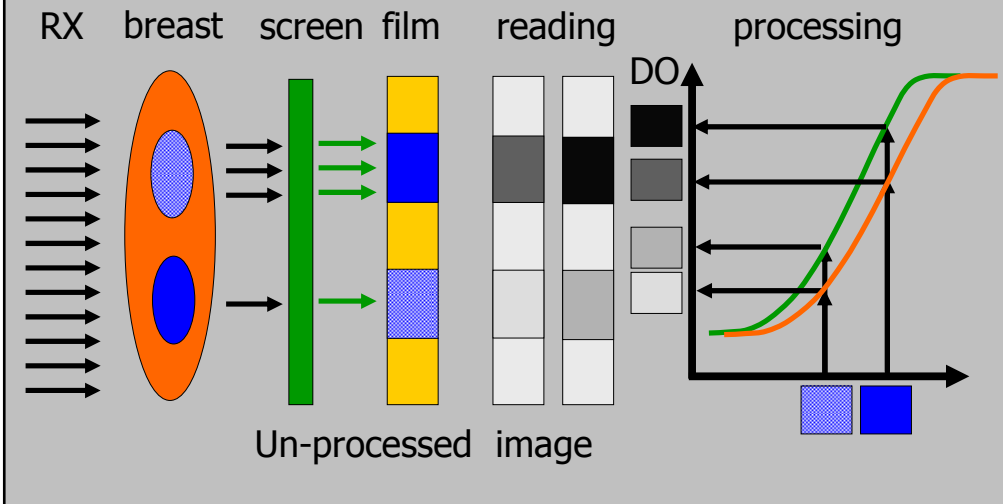

I - Intensity
D - Density
E - Exposure

Signal-to-Noise Ratio: SNR

$$\Delta C = [D_2 - D_1] / \sigma$$

Radiographic contrast

$$\Delta C = [D_2 - D_1] / D_1$$

Film contrast

$$\gamma = [D_2 - D_1] / [\log E_2 - \log E_1]$$

Subject Contrast $\Delta C = I_2 - I_1$

Visual contrast

$$\Delta C = \log I_2 - \log I_1$$

Basic Principles of Mammography

→ Use of low kV due to the type of imaged tissue

Photoelectric absorption :

$$\tau_m \approx 8(Z_{eff}\lambda)^3$$

Total absorption =
Photoelectric + Compton:

$$\mu = \sigma + \tau \approx \rho[0.2 + 8(Z_{eff}\lambda)^3]$$

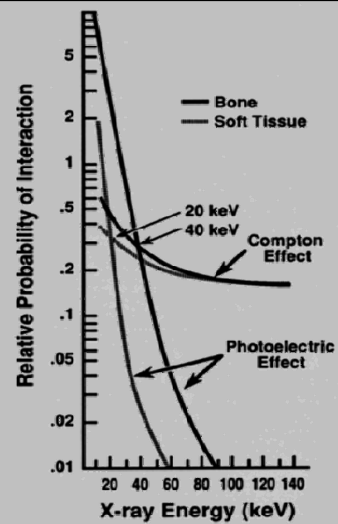

→ Some specific parameters of mammographic X-ray equipment

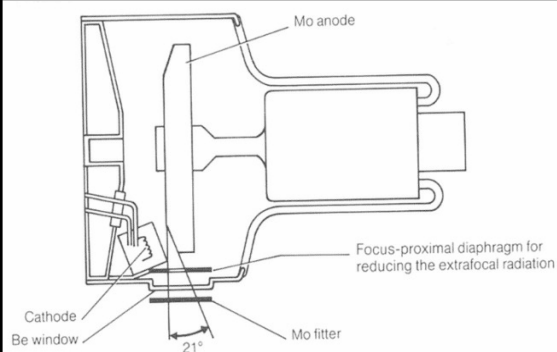

Parameter	
X-ray Generator	Medium frequency or at least 3 phase (~ 5 kW)
X-ray tube Anode + added filtration	Mo/ 30 μ m Mo Rh/ 50 μ m Rh W / 60 μ m Mo W / 50 μ m Rh
Focal spot	Small 0.1- 0.3 mm Large 0.4-0.6 mm
kV	20-35 kV, steps – 0.5-1 kV

→ X-ray spectrum from W anode with 0.06 mm Mo or 0.05 mm Rh filtration– 30 kV

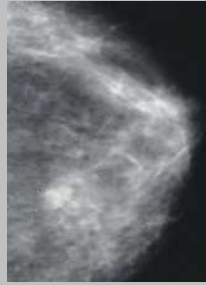
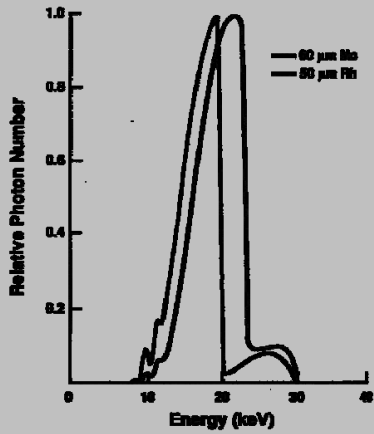
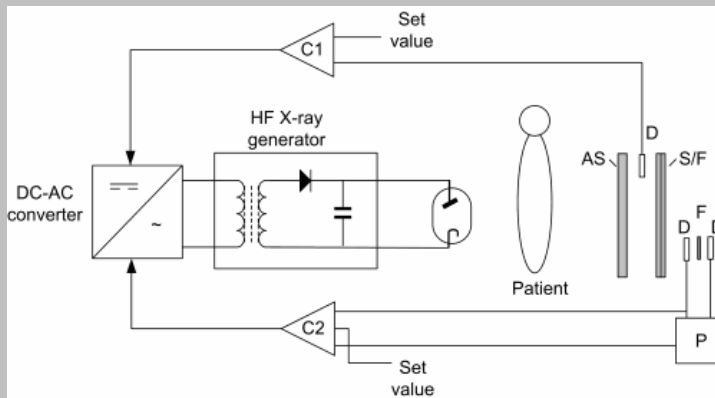

Fig. 20-4. The emission spectra from a tungsten target filtered by molybdenum or rhodium.

Automatic Exposure Control (AEC) system



Block diagram showing two typical AEC types.

C1 – used for chest radiography and C2 used for mammography.