

Workshop on  
Fully Programmable  
Systems-on-Chip for  
Scientific Applications

# *Embedded 'C' for Zynq*

---

***Cristian Sisterna***

Senior Associate, ICTP-MLAB 

Universidad Nacional San Juan - Argentina



# Differences Between 'C' and 'Embedded C'

---

Embedded systems programming is different from developing applications on a desktop computers. Key characteristics of an embedded system, when compared to PCs, are as follows:

- ❑ Embedded devices have resource constraints(limited ROM, limited RAM, limited stack space, less processing power)
- ❑ Components used in embedded system and PCs are different; embedded systems typically uses smaller, less power consuming components
- ❑ Embedded systems are more tied to the hardware
- ❑ Two salient features of Embedded Programming are ***code speed*** and ***code size***. Code speed is governed by the processing power, timing constraints, whereas code size is governed by available program memory and use of programming language.

# Difference Between C and Embedded C

---

Though **C** and **Embedded C** appear different and are used in different contexts, they have more similarities than the differences. Most of the constructs are same; the difference lies in their applications.

**C** is used for desktop computers, while **Embedded C** is for microcontroller based applications.

Compilers for **C** (ANSI C) typically generate OS dependent executables. **Embedded C** requires compilers to create files to be downloaded to the microcontrollers/microprocessors where it needs to run, moreover, give access to all resources which is not provided in compilers for desktop computer applications.

Embedded systems often have the real-time constraints, which is usually not there with desktop computer applications.

Embedded systems often do not have a console, which is available in case of desktop applications.

---

# Reviewing Embedded 'C' Basic Concepts

# 'C' Xilinx Basic Data Types

## `xbasic_types.h`

```
typedef unsigned char   Xuint8;    /**< unsigned 8-bit */
typedef char           Xint8;     /**< signed 8-bit */
typedef unsigned short Xuint16;   /**< unsigned 16-bit */
typedef short         Xint16;    /**< signed 16-bit */
typedef unsigned long  Xuint32;   /**< unsigned 32-bit */
typedef long          Xint32;    /**< signed 32-bit */
typedef float         Xfloat32;   /**< 32-bit floating point */
typedef double        Xfloat64;   /**< 64-bit double precision FP */
typedef unsigned long  Xboolean;  /**< boolean (XTRUE or XFALSE) */
```

## `xil_types.h`

```
typedef uint8_t  u8;
typedef uint16_t u16;
typedef uint32_t u32;
```

# Local vs Global Variables

Variables in 'C' can be classified by their scope

## Local Variables

Accessible only by the function within which they are declared and are allocated storage on *the stack*

## Global Variables

Accessible by any part of the program and are allocated permanent storage in RAM

# Global and Local Variables Declarations

---

Global

```
int flag = 0;  
char note = 'a';
```

```
main ()  
{
```

```
    ...  
    flag = 1;  
    function1( );  
    ...  
    flag = 2;  
    ...
```

```
}
```

```
int function1()
```

```
{
```

```
int alarm = 128;
```

```
    ...  
    alarm += 1;  
    flag = 3;  
    ...
```

```
}
```

Local



# Local vs Global Variables Memory Allocation

---

- ❖ **Local variables** only occupy RAM while the function to which they belong is running
- ❖ **Global variables** are allocated permanent storage in memory at an absolute address determined when the code is linked
  - ❖ The memory occupied by a *global variable* cannot be reused by any other variable
  - ❖ *Global variables* are not protected in any way, so any part of the program can access a global variable at any time
  - ❖ This means that the variable data could be corrupted if part of the variable is derived from one value and the rest of the variable is derived from another value



# Use of the 'static' modifier

❖ The '**static**' access modifier may be used with **global variables**

❖ This gives some degree of protection to the variable as it restricts access to the variable to those functions in the file in which the variable is declared

❖ The '**static**' access modifier may be used with **local variables**

❖ The 'static' access modifier causes that the local variable to be permanently allocated storage in memory, like a global variable, so the value is preserved between function calls (but still is local)

```
static int flag = 0;
static char note = 'a';

main ()
{
    ...
    flag = 1;
    function1( );
    ...
    flag = 2;
    ...
}

int function1()
{
    static int alarm = 128;
    ...
    alarm +=1;
    flag = 3;
    ..
}
```

# Volatile Variable

---

The value of ***volatile** variables* may change from outside the program.

For example, you may wish to read an A/D converter or a port whose value is changing.

*Often your compiler may eliminate code to read the port as part of the compiler's code optimization process if it does not realize that some outside process is changing the port's value.*

You can avoid this by declaring the variable ***volatile***.

# Volatile Variable - Example

```
1 #include <stdio.h>
2
3 /* Optimization code snippet 1 */
4 #include<stdio.h>
5
6 int x = 0;
7
8 int main()
9 {
10     if (x == 0) // This condition is always true
11     {
12         printf(" x = 0 \n");
13     }
14     else // Else part will be optimized be
15     {
16         printf(" x != 0 \n");
17     }
18     return 0;
19 }
```

```
1 #include<stdio.h>
2
3 volatile ir = 0; /* volatile Keyword*/
4
5 int main()
6 {
7     x = 0;
8
9     if (x == 0)
10    {
11        printf(" x = 0 \n");
12    }
13    else // Now compiler never optimize else part because the
14    { // variable is declared as volatile
15        printf(" x != 0 \n");
16    }
17    return 0;
18 }
```

# Functions Data Types

---

A function data type defines the value that a subroutine can return

- ❖ A function of type `int` returns a signed integer value
- ❖ Without a specific return type, any function returns an `int`
- ❖ To avoid confusion, you should always declare `main()` with return type `void`

```
void XGpioPs_IntrEnable(XGpioPs *InstancePtr, u8 Bank, u32 Mask);  
void XGpioPs_IntrDisable(XGpioPs *InstancePtr, u8 Bank, u32 Mask);  
u32 XGpioPs_IntrGetEnabled(XGpioPs *InstancePtr, u8 Bank);  
u32 XGpioPs_IntrGetStatus(XGpioPs *InstancePtr, u8 Bank);
```

# Function Parameters Data Types

Indicate the values to be passed into the function and the memory to be reserved for storing them

```
int XGpio_Initialize(XGpio *InstancePtr, u16 DeviceId);  
XGpio /**  
/* Initialize the XGpio instance provided by the caller based on the  
/* given DeviceID.  
/* A  
/*  
/*  
/* Nothing is done except to initialize the InstancePtr.  
/*  
/* @param InstancePtr is a pointer to an XGpio instance. The memory the  
/* pointer references must be pre-allocated by the caller. Further  
/* calls to manipulate the instance/driver through the XGpio API  
/* must be made with this pointer.  
/* @param DeviceId is the unique id of the device controlled by this XGpio  
/* instance. Passing in a device id associates the generic XGpio
```

# 'C' Structures

```
#include "xparameters.h"
#include "xgpio.h"
#include "xgpiops.h"

static XGpioPs psGpioInstancePtr;
static int iPinNumber = 7; /*Led LD9

//=====
/**
 * The XGpio driver instance data. The user is required to allocate a
 * variable of this type for every GPIO device in the system. A pointer
 * to a variable of this type is then passed to the driver API functions.
 */
int main (void)
{
    XGpio sw, led;
    int i, psnb_checked;

    typedef struct {
        u32 BaseAddress;      /* Device base address */
        u32 IsReady;         /* Device is initialized and ready */
        int InterruptPresent; /* Are interrupts supported in h/w */
        int IsDual;         /* Are 2 channels supported in h/w */
    } XGpio;
```

# Review of 'C' Pointer

In 'C', the pointer data type corresponds to a MEMORY ADDRESS

- a `int x = 1, y = 5, z = 8, *ptr;`
- b `ptr = &x; // ptr gets (point to) address of x`
- c `y = *ptr; // content of y gets content pointed by ptr`
- d `*ptr = z; // content pointed by ptr gets content of z`

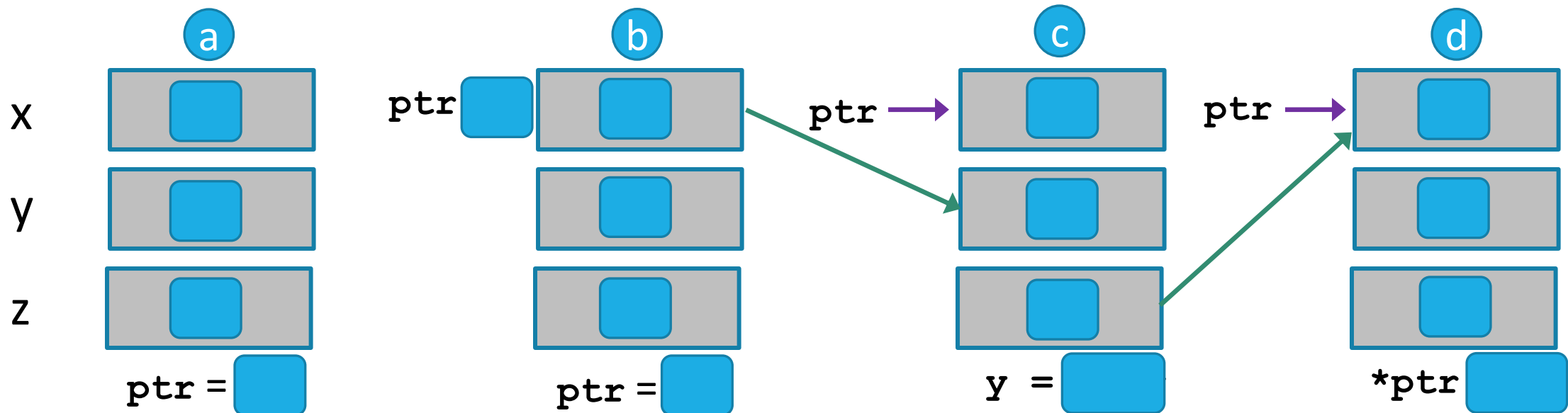

---

# 'C' Techniques for low-level I/O Operations



# Bit Manipulation in 'C'

Bitwise operators in 'C': `~` (**not**), `&` (**and**), `|` (**or**), `^` (**xor**)  
which operate on one or two operands at bit levels

```
u8 mask = 0x60;    //0110_0000 mask bits 6 and 5
u8 data = 0xb3     //1011_0011 data
u8 d0, d1, d2, d3; //data to work with in the coming example
. . .
```

```
d0 = data & mask; // 0010_0000; isolate bits 6 and 5 from data
d1 = data & ~mask; // 1001_0011; clear bits 6 and 5 of data
d2 = data | mask; // 1111_0011; set bits 6 and 5 of data
d3 = data ^ mask; // 1101_0011; toggle bits 6 and 5 of data
```

# Bit Shift Operators

---

Both operands of a bit shift operator must be integer values

The **right shift operator** shifts the data right by the specified number of positions. Bits shifted out the right side disappear. With unsigned integer values, 0s are shifted in at the high end, as necessary. For signed types, the values shifted in is implementation-dependant. The binary number is shifted right by *number* bits.

```
x >> number ;
```

The **left shift operator** shifts the data right by the specified number of positions. Bits shifted out the left side disappear and new bits coming in are 0s. The binary number is shifted left by *number* bits

```
x << number ;
```

# Bit Shift Example

```
void [REDACTED](XGpio *pLED_GPIO, int nNumberOfTimes)
{
    int i=0;      int j=0;
    u8 uchLedStatus=0;
    [REDACTED]
    for(i=0; i<nNumberOfTimes; i++)
    {
        for(j=0; j<8; j++) [REDACTED] p
        {
            uchLedStatus = 1 << j;
            XGpio_DiscreteWrite(pLED_GPIO, 1, uchLedStatus);
            delay(ABOUT_ONE_SECOND / 15);
        }
        for(j=0; j<8; j++) [REDACTED] n
        {
            uchLedStatus = 8 >> j;
            XGpio_DiscreteWrite(pLED_GPIO, 1, uchLedStatus);
            delay(ABOUT_ONE_SECOND / 15);
        }
    }
}
```

# Unpacking Data

There are cases that in the same memory address different fields are stored

Example: let's assume that a 32-bit memory address contains a 16-bit field for an integer data and two 8-bit fields for two characters

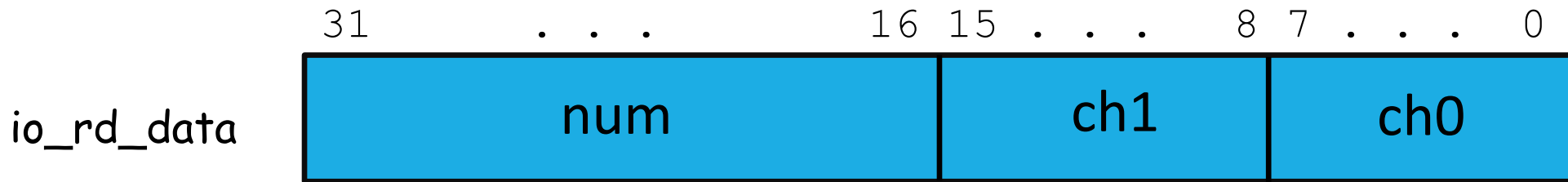

```
u32 io_rd_data;  
int num;  
char ch1, ch0;
```

Unpacking {

```
io_rd_data = my_iord(...); //my_io_read read a data  
num = (int) ((io_rd_data & 0xffff0000) >> 16);  
ch1 = (char) ((io_rd_data & 0x0000ff00) >> 8);  
ch0 = (char) ((io_rd_data & 0x000000ff) );
```

# Packing Data

There are cases that in the same memory address different fields are written

Example: let's assume that a 32-bit memory address will be written as a 16-bit field for an integer data and two 8-bit fields for two characters



```
u32 wr_data;  
int num = 5;  
char ch1, ch0;
```

Packing {

```
wr_data = (u32) (num); //num[15:0]  
wr_data = (wr_data << 8) | (u32) ch1; //num[23:8], ch1[7:0]  
wr_data = (wr_data << 8) | (u32) ch0; //num[31:16], ch1[15:8]  
my_iowr( . . . , wr_data) ; //ch0[7:0]
```

# Another Way ....

```
u32 wr_data;  
int num = 5;  
char ch1, ch0;
```

```
wr_data = (u32) (num); //num[15:0]  
wr_data = (wr_data << 8) | (u32) ch1; //num[23:8], ch1[7:0]  
wr_data = (wr_data << 8) | (u32) ch0; //num[31:16], ch1[15:8]  
my_iowr( . . . , wr_data) ; //ch0[7:0]
```

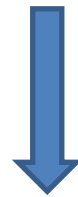

```
wr_data = (((u32) (num)) << 16) | (((u32) ch1) << 8) | (u32) ch2;
```

---

# Basic Embedded 'C' Program Template

# Basic Embedded Program Architecture

An embedded application consists of a collection tasks, implemented by hardware accelerators, software routines, or both.

```
#include "nnnnn.h"
#include <ppppp.h>
main ()
{
    sys_init(); //
    while(1) {
        task_1();
        task_2();
        . . .
        task_n();
    }
}
```



# Basic Example

---

The flashing-LED system turns on and off *two* LEDs alternatively according to the interval specified by the *ten* sliding switches

Tasks ????



1. reading the interval value from the switches
2. toggling the two LEDs after a specific amount of time

# Basic Example

---

```
main ()
{
while (1) {
    . . .
    task_1 ();
    task_2 ();
    . . .
}
}
```

```
#include "nnnnn.h"
#include "aaaaa.h"
```

```
main ()
{
int period;

while (1) {
    read_sw (SWITCH_S1_BASE, &period);
    led_flash (LED_L1_BASE, period);
}
}
```

# Basic Example - Reading

```
/*
*****
* function: read_sw ()
* purpose: get flashing period from 10 switches
* argument:
*     sw-base: base address of switch PIO
*     period: pointer to period
* return:
*     updated period
* note :
*****
void read_sw(u32 switch_base, int *period)
{
    *period = my_iord(switch_base) & 0x000003ff; //read flashing period
                                                    // from switch
}
```

# Basic Example - Writing

```
/******  
* function: led.flash ()  
* purpose: toggle 2 LEDs according to the given period  
* argument:  
*     led-base: base address of discrete LED PIO  
*     period: flashing period in ms  
* return : none  
* note :  
* - The delay is done by estimating execution time of a dummy for loop  
* - Assumption: 400 ns per loop iteration (2500 iterations per ms)  
* - 2 instruct. per loop iteration /10 clock cycles per instruction /20ns per clock cycle(50-MHz clock)  
*****/  
void led_flash(u32 addr_led_base, int period)  
{  
    static u8 led_pattern = 0x01;           // initial pattern  
    unsigned long i, itr;  
  
    led_pattern ^= 0x03;                   // toggle 2 LEDs (2 LSBs)  
    my_iowr(addr_led_base, led_pattern);   // write LEDs  
    itr = period * 2500;  
    for (i=0; i<itr; i++) {}               // dummy loop for delay  
}
```

# Basic Example – Read / Write

```
int main()
{
    int period;

    while(1) {
        read_sw(SWITCH_S1_BASE, &period);
        led_flash(LED_L1_BASE, period);
    }

    return 0;
}
```

```
void read_sw(u32 switch_base, int *period)
{
    *period = my_iord(switch_base) & 0x000003ff;
}
```

```
void led_flash(u32 addr_led_base, int period)
{
    static u8 led_pattern = 0x01;
    unsigned long i, itr;           //static?

    led_pattern ^= 0x03;
    my_iowr(addr_led_base, led_pattern);
    itr = period * 2500;
    for (i=0; i<itr; i++) {}
}
```

---

# Read/Write From/To GPIO Inputs and Outputs

# Read / Write IP Blocks

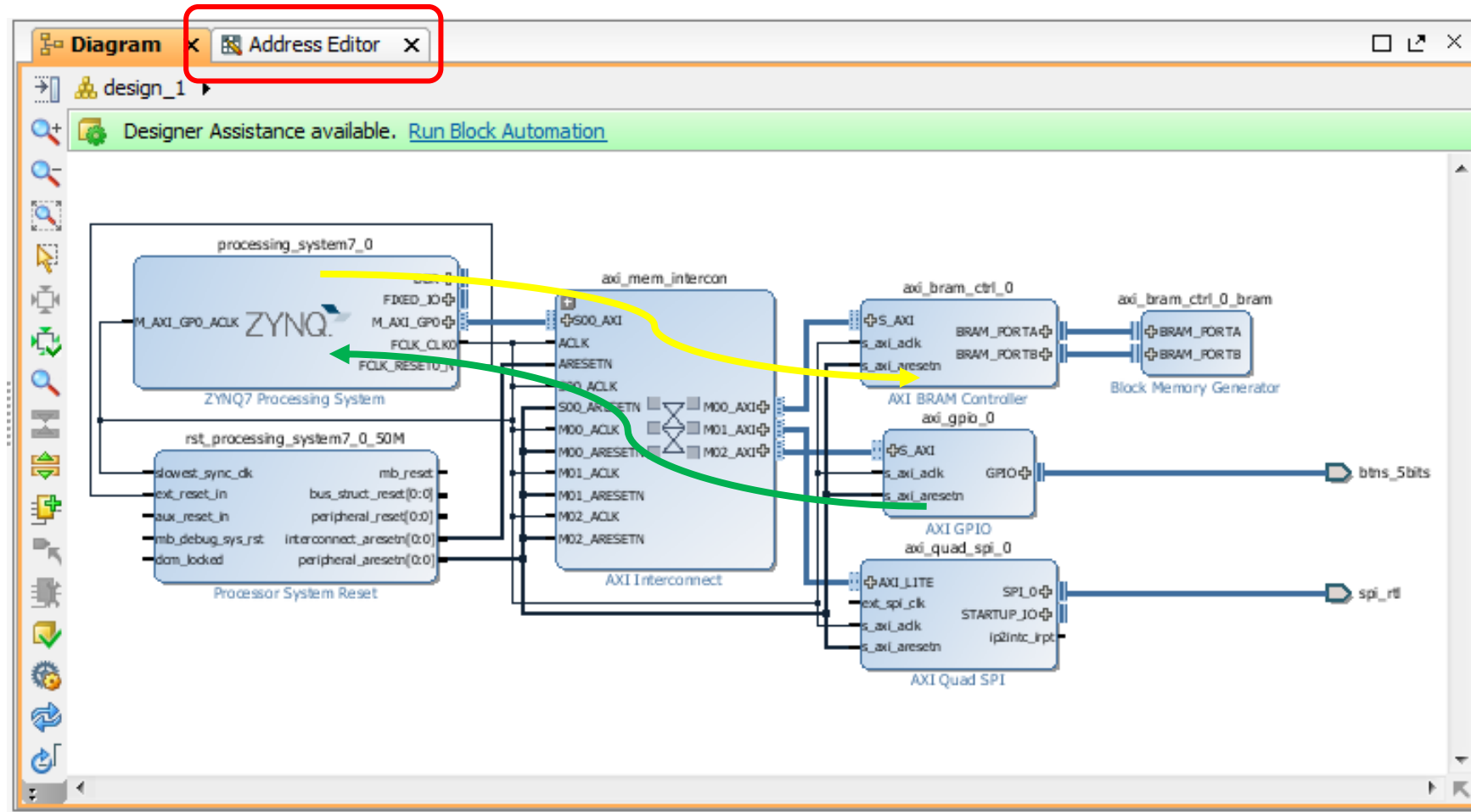

# Vivado Address Map

Memory-Map  
Address Space

Cell	Slave Interface	Base Name	Offset Address	Range	High Address
Data (32 address bits : 0x00000000 [ 1G ])					
axi_bram_ctrl_0	S_AXI	Mem0	0x4000_0000	8K	0x4000_1FFF
axi_quad_spi_0	AXI LITE	Reg	0x41E0_0000	64K	0x41E0_FFFF
axi_gpio_0	S_AXI	Reg	0x4120_0000	64K	0x4120_FFFF

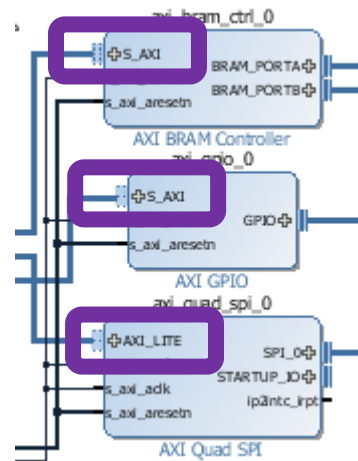



# Memory Location Mnemonics

---

 xparameters.h 

 lab\_gpio\_in\_...

 xgpiops\_hw.h

```
/* Definitions for peripheral BOARD_LEDS_8B */  
#define XPAR_BOARD_LEDS_8B_BASEADDR 0x41210000  
#define XPAR_BOARD_LEDS_8B_HIGHADDR 0x4121FFFF  
#define XPAR_BOARD_LEDS_8B_DEVICE_ID 0  
#define XPAR_BOARD_LEDS_8B_INTERRUPT_PRESENT 0  
#define XPAR_BOARD_LEDS_8B_IS_DUAL 0
```

# Steps for Reading from a GPIO

---

1. Create a GPIO instance
2. Initialize the GPIO
3. Set data direction (optional)
4. Read the data

# Steps for Reading from a GPIO – Step 1

## 1. Create a GPIO instance

```
#include "xparameters.h"
#include "xgpio.h"
int main(void)
{
    XGpio switches;
    XGpio leds;
    ...
}

/**
 * The XGpio driver instance data. The user is required to allocate a
 * variable of this type for every GPIO device in the system. A pointer
 * to a variable of this type is then passed to the driver API functions.
 */
typedef struct {
    u32 BaseAddress;      /* Device base address */
    u32 IsReady;          /* Device is initialized and ready */
    int InterruptPresent; /* Are interrupts supported in h/w */
    int IsDual;           /* Are 2 channels supported in h/w */
} XGpio;
```

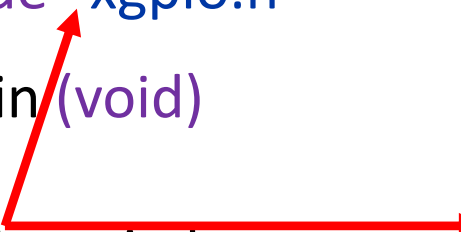

# Steps for Reading from a GPIO – Step 2

## 2. Initialize the GPIO

```
(int) XGpio_Initialize(XGpio *InstancePtr, u16 DeviceID);
```

**InstancePtr**: is a pointer to an **XGpio** instance (already declared).

**DeviceID**: is the unique **ID** of the device controlled by this **XGpio** component (declared in the *xparameters.h* file)

### @return

- XST\_SUCCESS if the initialization was successful.
  - XST\_DEVICE\_NOT\_FOUND if the device configuration data was not
- } xstatus.h

# Steps for Reading from a GPIO – Step 2(cont')

```
(int) XGpio_Initialize(XGpio *InstancePtr, u16 DeviceID);
```

```
// AXI GPIO switches initialization
```

```
XGpio_Initialize (&switches, XPAR_BOARD_SW_8B_DEVICE_ID);
```

```
// AXI GPIO leds initialization
```

```
XGpio_Initialize (&led, XPAR_BOARD_LEDS_8B_DEVICE_ID);
```

```
./xparameters.h lab_gpio_in... ./xgpiops_hw.h
```

```
/* Definitions for peripheral BOARD_LEDS_8B */  
#define XPAR_BOARD_LEDS_8B_BASEADDR 0x41210000  
#define XPAR_BOARD_LEDS_8B_HIGHADDR 0x4121FFFF  
#define XPAR_BOARD_LEDS_8B_DEVICE_ID 0  
#define XPAR_BOARD_LEDS_8B_INTERRUPT_PRESENT 0  
#define XPAR_BOARD_LEDS_8B_IS_DUAL 0
```

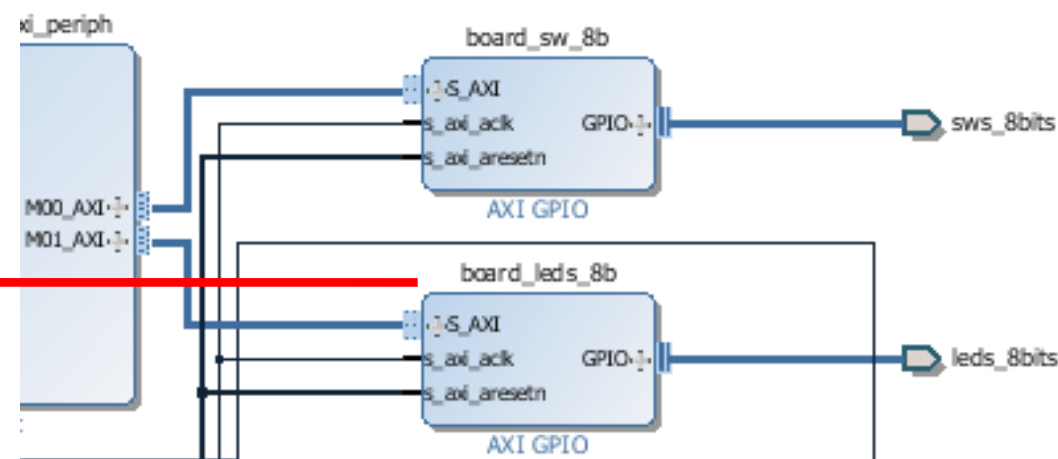

# xparameters.h

- exercise\_05\_bsp
  - BSP Documentation
  - ps7\_cortexa9\_0
    - code
    - include

```
lab_gpio_in_out.c
```

```
#include "xparameters.h"  
#include "xgpio.h"  
#include "xgpiops.h"
```

Ctrl + Mouse Over

*xparameters.h* file can be found underneath the include folder in the ps7\_cortexa9\_0 folder of the BSP main folder

# xparameters.h

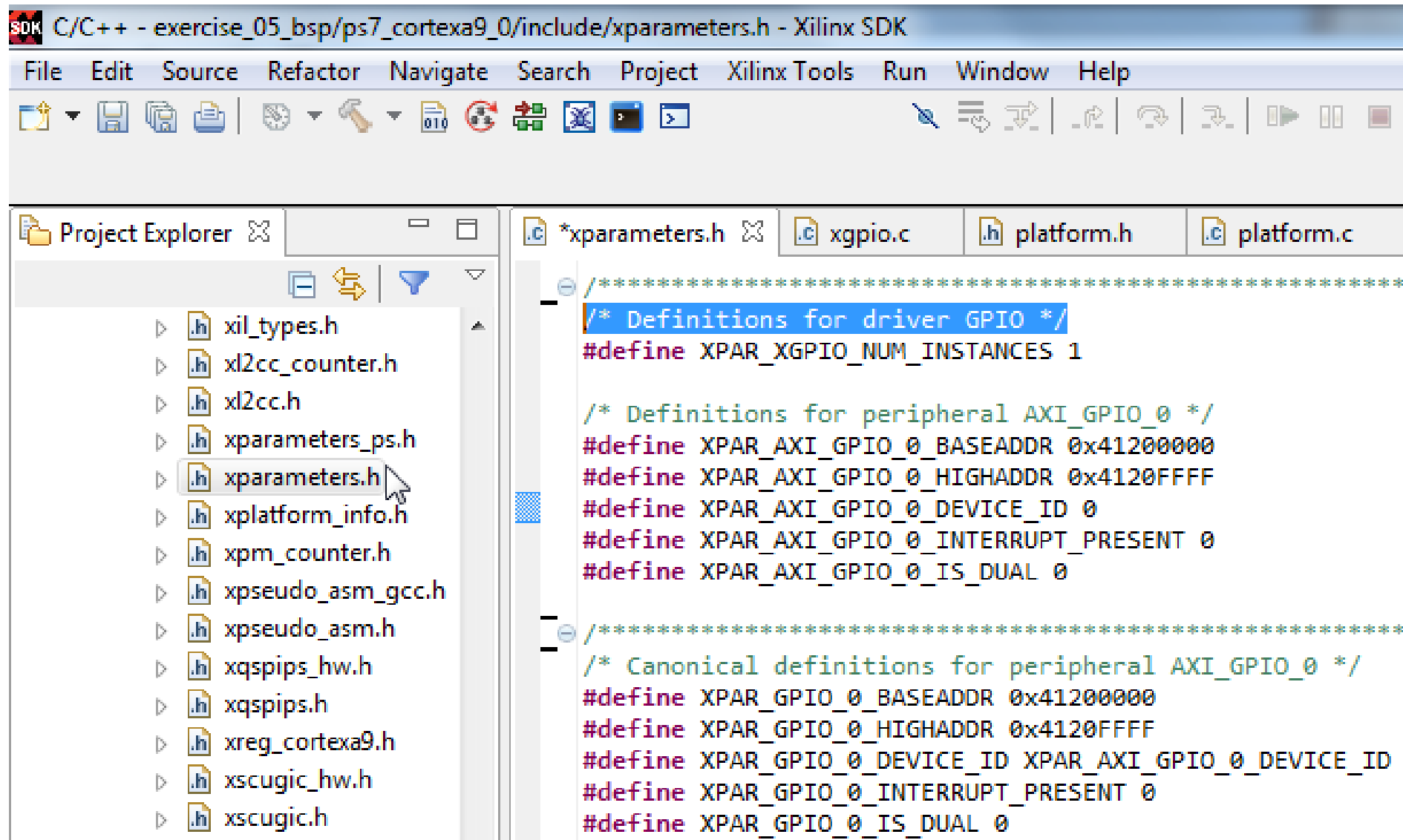

```
SDK C/C++ - exercise_05_bsp/ps7_cortexa9_0/include/xparameters.h - Xilinx SDK
File Edit Source Refactor Navigate Search Project Xilinx Tools Run Window Help
Project Explorer
  .h xil_types.h
  .h xl2cc_counter.h
  .h xl2cc.h
  .h xparameters_ps.h
  .h xparameters.h
  .h xplatform_info.h
  .h xpm_counter.h
  .h xpseudo_asm_gcc.h
  .h xpseudo_asm.h
  .h xqspips_hw.h
  .h xqspips.h
  .h xreg_cortexa9.h
  .h xscugic_hw.h
  .h xscugic.h
*xparameters.h
.xgpio.c
.h platform.h
.c platform.c
/*****
/* Definitions for driver GPIO */
#define XPAR_XGPIO_NUM_INSTANCES 1

/* Definitions for peripheral AXI_GPIO_0 */
#define XPAR_AXI_GPIO_0_BASEADDR 0x41200000
#define XPAR_AXI_GPIO_0_HIGHADDR 0x4120FFFF
#define XPAR_AXI_GPIO_0_DEVICE_ID 0
#define XPAR_AXI_GPIO_0_INTERRUPT_PRESENT 0
#define XPAR_AXI_GPIO_0_IS_DUAL 0

/*****
/* Canonical definitions for peripheral AXI_GPIO_0 */
#define XPAR_GPIO_0_BASEADDR 0x41200000
#define XPAR_GPIO_0_HIGHADDR 0x4120FFFF
#define XPAR_GPIO_0_DEVICE_ID XPAR_AXI_GPIO_0_DEVICE_ID
#define XPAR_GPIO_0_INTERRUPT_PRESENT 0
#define XPAR_GPIO_0_IS_DUAL 0
```

# Steps for Reading from a GPIO - Step 3

---

## 3. Set data direction

```
void XGpio_SetDataDirection (XGpio *InstancePtr, unsigned Channel, u32 DirectionMask);
```

**InstancePtr:** is a pointer to an XGpio instance to be working with.

**Channel:** contains the channel of the XGpio (1 or 2) to operate with.

**DirectionMask:** is a bitmask specifying which bits are inputs and which are outputs. Bits set to '0' are **output**, bits set to '1' are **inputs**.

**Return:** none



# Steps for Reading from a GPIO - Step 3 (cont')

```
void XGpio_SetDataDirection (XGpio *InstancePtr, unsigned Channel, u32 DirectionMask);
```

```
// AXI GPIO switches: bits direction configuration
```

```
XGpio_SetDataDirection(&board_sw_8b, 1, 0xffffffff);
```

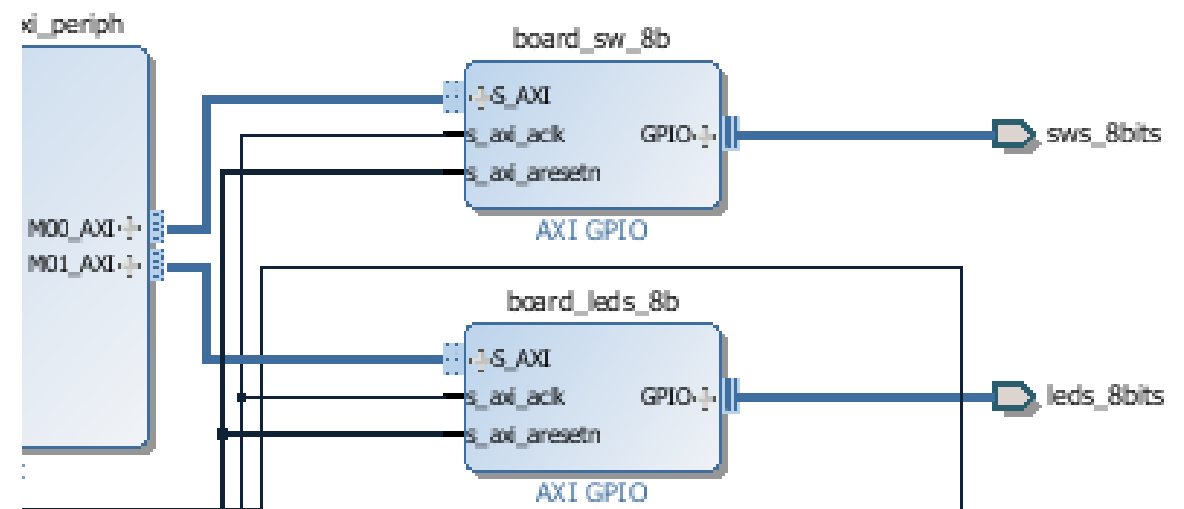

# Steps for Reading from a GPIO – Step 4

---

## 4. Read the data

```
u32 XGpio_DiscreteRead (XGpio *InstancePtr, unsigned Channel);
```

**InstancePtr:** is a pointer to an XGpio instance to be working with.

**Channel:** contains the channel of the XGpio (1 or 2) to operate with.

**Return:** read data

# Steps for Reading from a GPIO – Step 4 (cont')

---

```
u32 XGpio_DiscreteRead (XGpio *InstancePtr, unsigned Channel);
```

```
// AXI GPIO: read data from the switches  
sw_check = XGpio_DiscreteRead(&board_sw_8b, 1);
```

# Steps for Writing to GPIO

---

1. Create a GPIO instance
2. Initialize the GPIO
3. Set the data direction (optional)
4. Read the data

# Steps for Writing to a GPIO – Step 1

## 1. Create a GPIO instance

```
#include "xgpio.h"
int main (void)
{
    XGpio switches;
    XGpio leds;
    ...
}

/**
 * The XGpio driver instance data. The user is required to allocate a
 * variable of this type for every GPIO device in the system. A pointer
 * to a variable of this type is then passed to the driver API functions.
 */
typedef struct {
    u32 BaseAddress;           /* Device base address */
    u32 IsReady;              /* Device is initialized and ready */
    int InterruptPresent;     /* Are interrupts supported in h/w */
    int IsDual;               /* Are 2 channels supported in h/w */
} XGpio;
```

# Steps for Writing to a GPIO – Step 2

## 2. Initialize the GPIO

```
(int) XGpio_Initialize(XGpio *InstancePtr, u16 DeviceID);
```

**InstancePtr**: is a pointer to an XGpio instance.

**DeviceID**: is the unique id of the device controlled by this XGpio component

### @return

- XST\_SUCCESS if the initialization was successful.
  - XST\_DEVICE\_NOT\_FOUND if the device configuration data was not
- } xstatus.h

# Steps for Writing to a GPIO – Step 2(cont’)

```
(int) XGpio_Initialize (XGpio *InstancePtr, u16 DeviceID);
```

```
// AXI GPIO LEDs initialization
```

```
XGpio_Initialize (&board_leds_8b, XPAR_BOARD_LEDS_8B_DEVICE_ID);
```

```
xparameters.h lab_gpio_in... xgpiops_hw.h
```

```
/* Definitions for peripheral BOARD_LEDS_8B */  
#define XPAR_BOARD_LEDS_8B_BASEADDR 0x41210000  
#define XPAR_BOARD_LEDS_8B_HIGHADDR 0x4121FFFF  
#define XPAR_BOARD_LEDS_8B_DEVICE_ID 0  
#define XPAR_BOARD_LEDS_8B_INTERRUPT_PRESENT 0  
#define XPAR_BOARD_LEDS_8B_IS_DUAL 0
```

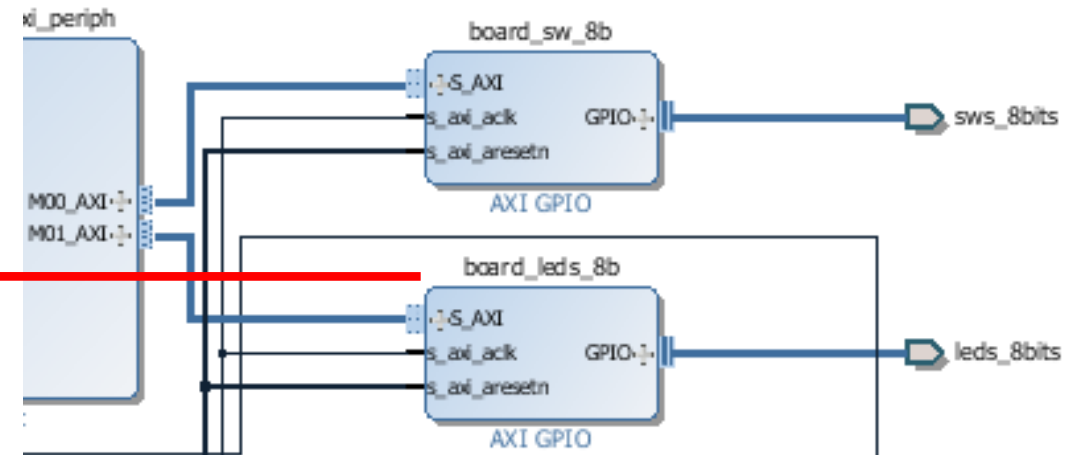

# Steps for Writing to a GPIO – Step 3

---

## 3. Write the data

```
void XGpio_DiscreteWrite (XGpio *InstancePtr, unsigned Channel, u32 Data);
```

**InstancePtr:** is a pointer to an XGpio instance to be worked on.

**Channel:** contains the channel of the XGpio (1 or 2) to operate with.

**Data:** Data is the value to be written to the discrete register

**Return:** none



# Steps for Writing to a GPIO – Step 3 (cont')

---

```
void XGpio_DiscreteWrite (XGpio *InstancePtr, unsigned Channel, u32 Data);
```

```
// AXI GPIO: write data (sw_check) to the LEDs  
XGpio_DiscreteWrite(& board_leds_8b, 1, sw_check);
```

---

# 'C' Drivers for IP Cores

# SPI IP Core - Example

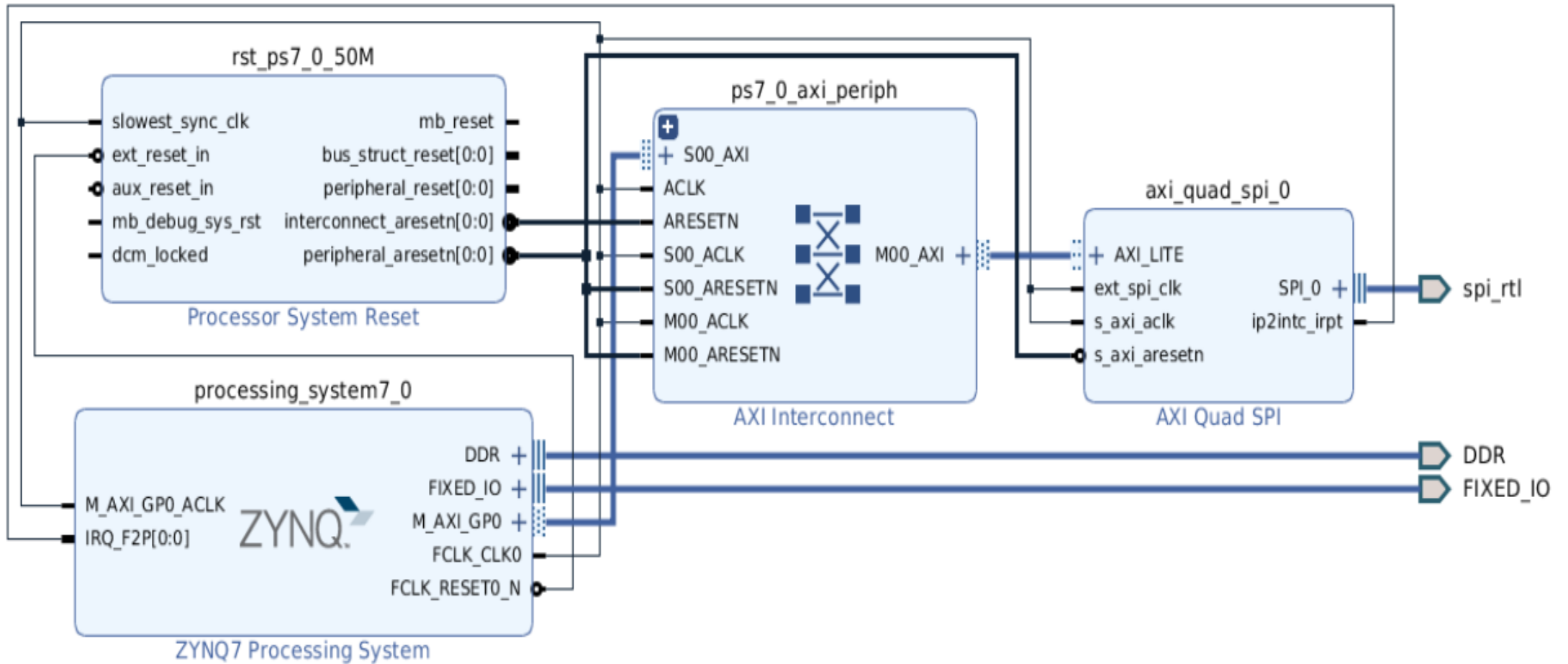

# SPI IP Core - Example

---

```
#include "xparameters.h"  
#include "xscugic.h"  
#include "xil_exception.h"  
#include <stdio.h>  
#include "xspi.h"      /* SPI device driver */
```



```
// ----- SPI related functions ----- //  
// Initialize the SPI driver  
SPI_ConfigPtr = XSpi_LookupConfig(XPAR_AXI_QUAD_SPI_0_DEVICE_ID);  
if (SPI_ConfigPtr == NULL) return XST_DEVICE_NOT_FOUND;  
  
Status = XSpi_CfgInitialize(&SpiInstance, SPI_ConfigPtr, SPI_ConfigPtr->BaseAddress);  
if (Status != XST_SUCCESS) return XST_FAILURE;  
  
// Reset the SPI peripheral  
XSpi_Reset(&SpiInstance);
```

# SPI IP Core - Example

```

/*****
/**
 *
 * Initializes a specific XSpi instance such that the driver is ready to use.
 *
 * The state of the device after initialization is:
 * - Device is disabled
 * - Slave mode
 * - Active high clock polarity
 * - Clock phase 0
 *
 * @param InstancePtr is a pointer to the XSpi instance to be worked on.
 * @param Config is a reference to a structure containing information
 * about a specific SPI device. This function initializes an
 * InstancePtr object for a specific device specified by the
 * contents of Config. This function can initialize multiple
 * instance objects with the use of multiple calls giving
 * different Config information on each call.
 * @param EffectiveAddr is the device base address in the virtual memory
 * address space. The caller is responsible for keeping the
 * address mapping from EffectiveAddr to the device physical base
 * address unchanged once this function is invoked. Unexpected
 * errors may occur if the address mapping changes after this
 * function is called. If address translation is not used, use
 * Config->BaseAddress for this parameters, passing the physical
 * address instead.
 *
 * @return
 * - XST_SUCCESS if successful.
 * - XST_DEVICE_IS_STARTED if the device is started. It must be
 * stopped to re-initialize.
 *
 * @note None.
 *
 *****/
int XSpi_CfgInitialize(XSpi *InstancePtr, XSpi_Config *Config,
                      UINTPTR EffectiveAddr)

```

---

# 'C' Drivers for Custom IP

# Custom IP

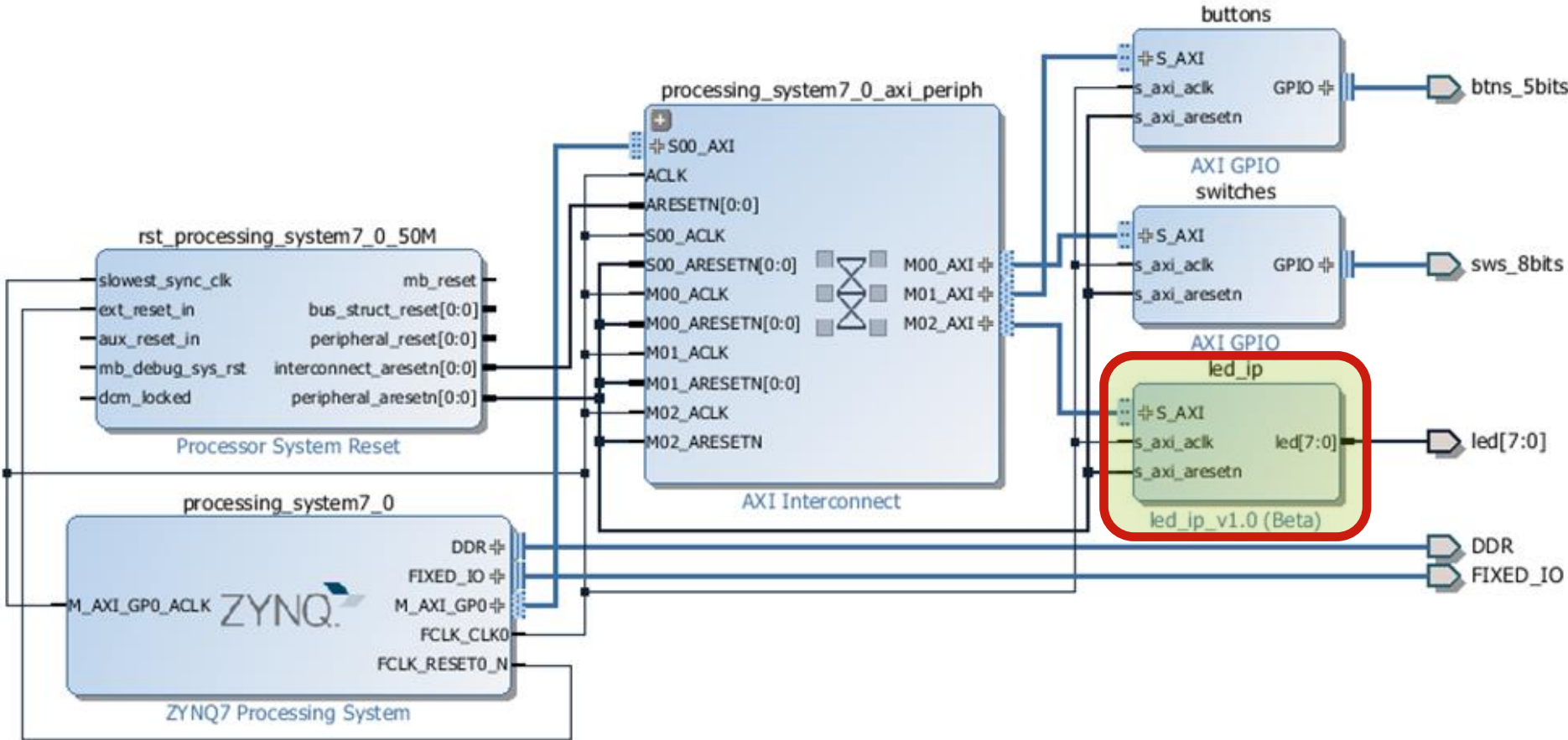

# My IP – Memory Address Range

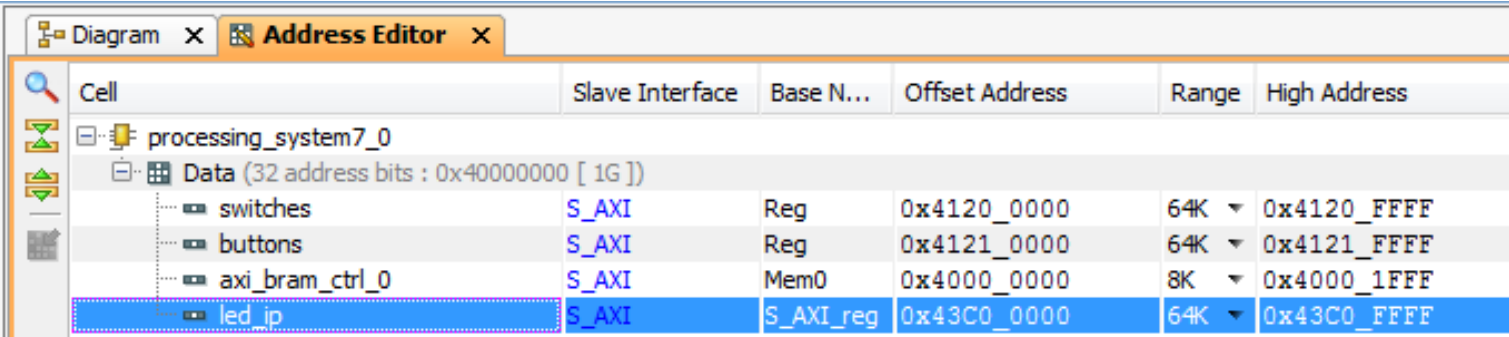

Cell	Slave Interface	Base N...	Offset Address	Range	High Address
processing_system7_0					
Data (32 address bits : 0x40000000 [ 1G ])					
switches	S_AXI	Reg	0x4120_0000	64K	0x4120_FFFF
buttons	S_AXI	Reg	0x4121_0000	64K	0x4121_FFFF
axi_bram_ctrl_0	S_AXI	Mem0	0x4000_0000	8K	0x4000_1FFF
led_ip	S_AXI	S_AXI_reg	0x43C0_0000	64K	0x43C0_FFFF



# Custom IP Drivers

- The *driver code* are generated automatically when the IP template is created.
- The *driver* includes higher level functions which can be called from the user application.
- The *driver* will implement the low level functionality used to control your peripheral.

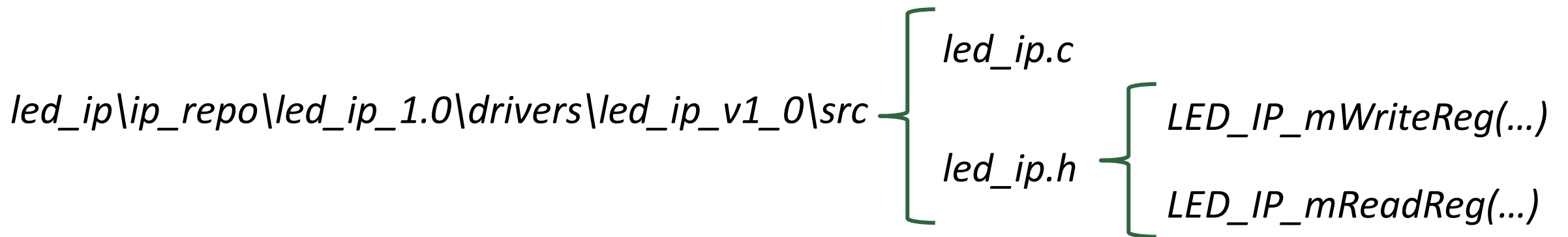

# Custom IP Drivers: \*.c

*led\_ip\ip\_repo\led\_ip\_1.0\drivers\led\_ip\_v1\_0\src\led\_ip.c*

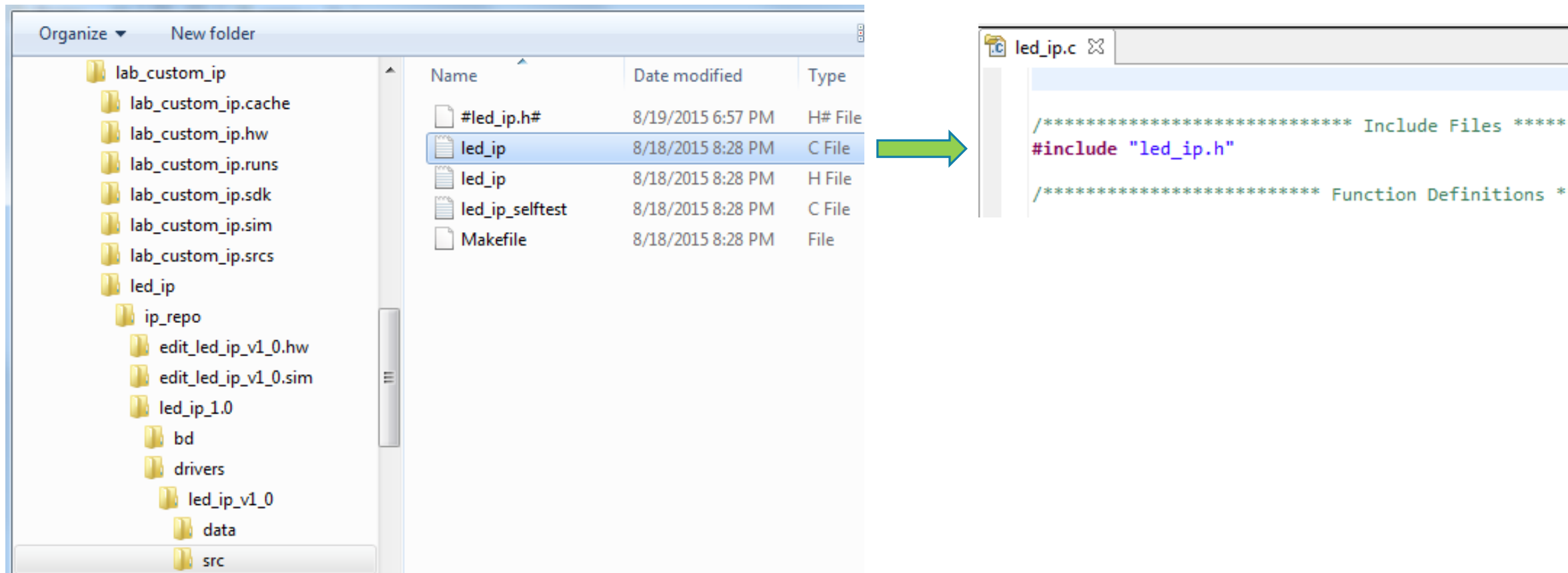

The image shows a file explorer window on the left and a code editor window on the right. The file explorer displays a directory tree with the following structure:

- lab\_custom\_ip
  - lab\_custom\_ip.cache
  - lab\_custom\_ip.hw
  - lab\_custom\_ip.runs
  - lab\_custom\_ip.sdk
  - lab\_custom\_ip.sim
  - lab\_custom\_ip.srcs
  - led\_ip
    - ip\_repo
      - edit\_led\_ip\_v1\_0.hw
      - edit\_led\_ip\_v1\_0.sim
      - led\_ip\_1.0
        - bd
        - drivers
          - led\_ip\_v1\_0
            - data
            - src

The file explorer's right pane shows a table of files in the selected directory:

Name	Date modified	Type
#led_ip.h#	8/19/2015 6:57 PM	H# File
led_ip	8/18/2015 8:28 PM	C File
led_ip	8/18/2015 8:28 PM	H File
led_ip_selftest	8/18/2015 8:28 PM	C File
Makefile	8/18/2015 8:28 PM	File

A green arrow points from the 'led\_ip' file in the table to the code editor window. The code editor shows the following code:

```
led_ip.c
/***** Include Files *****/
#include "led_ip.h"
/***** Function Definitions *****/
```

# Custom IP Drivers: \*.h

*led\_ip\ip\_repo\led\_ip\_1.0\drivers\led\_ip\_v1\_0\src\led\_ip.h*

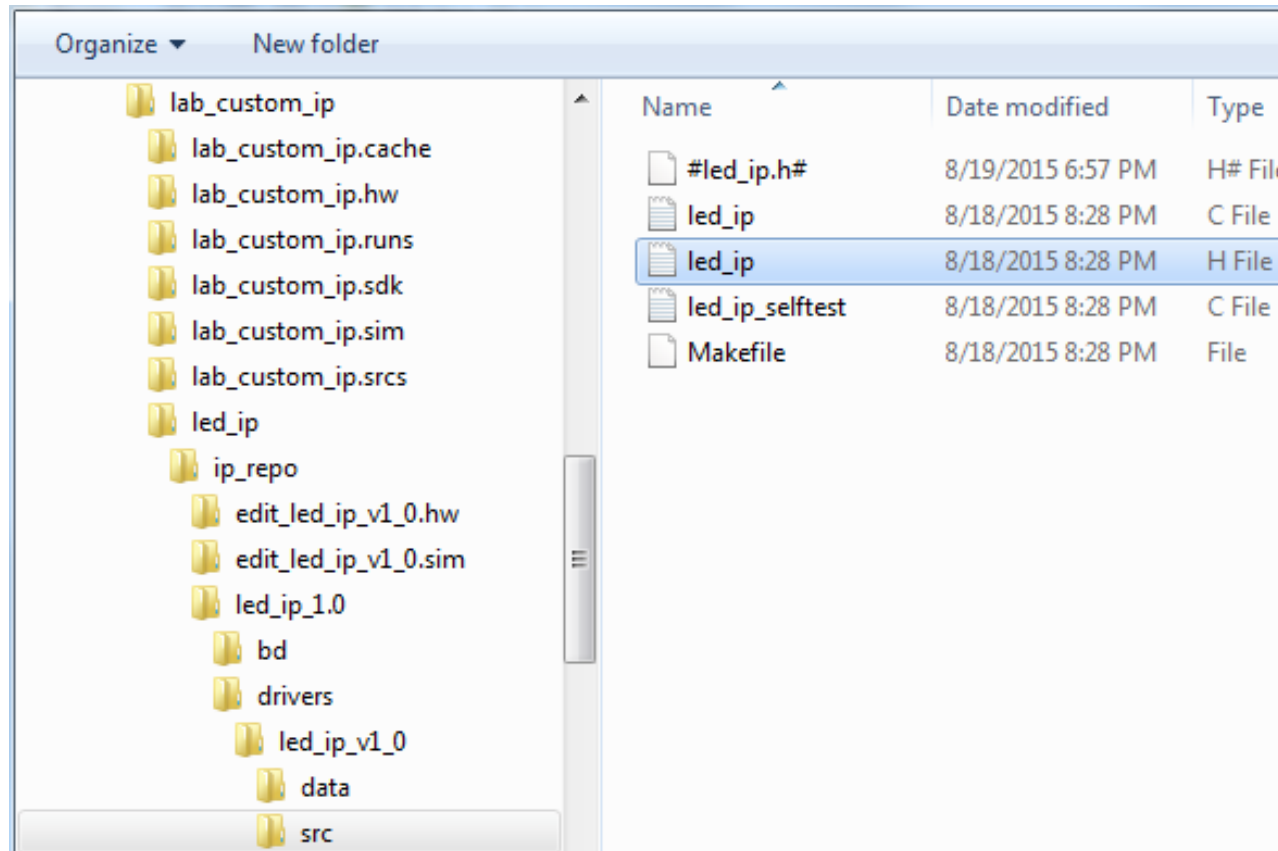

# Custom IP Drivers: \*.h (cont' 1)

---

*led\_ip\ip\_repo\led\_ip\_1.0\drivers\led\_ip\_v1\_0\src\led\_ip.h*

```
led_ip.h ⌵  
  
/***** Include Files *****/  
#include "xil_types.h"  
#include "xstatus.h"  
  
#define LED_IP_S_AXI_SLV_REG0_OFFSET 0  
#define LED_IP_S_AXI_SLV_REG1_OFFSET 4  
#define LED_IP_S_AXI_SLV_REG2_OFFSET 8  
#define LED_IP_S_AXI_SLV_REG3_OFFSET 12
```

# Custom IP Drivers: \*.h (cont' 2)

---

*led\_ip\ip\_repo\led\_ip\_1.0\drivers\led\_ip\_v1\_0\src\led\_ip.h*

```
/**
 *
 * Write a value to a LED_IP register. A 32 bit write is performed.
 * If the component is implemented in a smaller width, only the least
 * significant data is written.
 *
 * @param BaseAddress is the base address of the LED_IPdevice.
 * @param RegOffset is the register offset from the base to write to.
 * @param Data is the data written to the register.
 *
 * @return None.
 *
 * @note
 * C-style signature:
 * void LED_IP_mWriteReg(u32 BaseAddress, unsigned RegOffset, u32 Data)
 */
#define LED_IP_mWriteReg(BaseAddress, RegOffset, Data) \
    Xil_Out32((BaseAddress) + (RegOffset), (u32)(Data))
```

# Custom IP Drivers: \*.h (cont' 3)

---

*led\_ip\ip\_repo\led\_ip\_1.0\drivers\led\_ip\_v1\_0\src\led\_ip.h*

```
/**
 *
 * Read a value from a LED_IP register. A 32 bit read is performed.
 * If the component is implemented in a smaller width, only the least
 * significant data is read from the register. The most significant data
 * will be read as 0.
 *
 * @param BaseAddress is the base address of the LED_IP device.
 * @param RegOffset is the register offset from the base to write to.
 *
 * @return Data is the data from the register.
 *
 * @note
 * C-style signature:
 * u32 LED_IP_mReadReg(u32 BaseAddress, unsigned RegOffset)
 *
 */
#define LED_IP_mReadReg(BaseAddress, RegOffset) \
    Xil_In32((BaseAddress) + (RegOffset))
```

# Custom IP Drivers: \*.h (cont' 4)

---

*led\_ip\ip\_repo\led\_ip\_1.0\drivers\led\_ip\_v1\_0\src\led\_ip.h*

```
/**
 *
 * Run a self-test on the driver/device. Note this may be a destructive test if
 * resets of the device are performed.
 *
 * If the hardware system is not built correctly, this function may never
 * return to the caller.
 *
 * @param  baseaddr_p is the base address of the LED_IP instance to be worked on
 *
 * @return
 *
 * - XST_SUCCESS   if all self-test code passed
 * - XST_FAILURE   if any self-test code failed
 *
 * @note    Caching must be turned off for this function to work.
 * @note    Self test may fail if data memory and device are not on the same bus.
 */
XStatus LED_IP_Reg_SelfTest(void * baseaddr_p);
```

# 'C' Code for Writing to My\_IP

```
#include "xparameters.h"
#include "xgpio.h"
#include "led_ip.h"

//=====
int main (void)
{
    XGpio dip, push;
    int i, psb_check, dip_check;

    xil_printf("-- Start of the Program --\r\n");

    XGpio_Initialize(&dip, XPAR_SWITCHES_DEVICE_ID);
    XGpio_SetDataDirection(&dip, 1, 0xffffffff);

    XGpio_Initialize(&push, XPAR_BUTTONS_DEVICE_ID);
    XGpio_SetDataDirection(&push, 1, 0xffffffff);

    while (1)
    {
        psb_check = XGpio_DiscreteRead(&push, 1);
        xil_printf("Push Buttons Status %x\r\n", psb_check);
        dip_check = XGpio_DiscreteRead(&dip, 1);
        xil_printf("DIP Switch Status %x\r\n", dip_check);

        for (i=0; i<9999999; i++);
    }
}
```



# IP Drivers – *Xil\_Out32/Xil\_In32*

---

```
#define LED_IP_mWriteReg(BaseAddress, RegOffset, Data) Xil_Out32((BaseAddress) + (RegOffset), (Xuint32)(Data))
```

```
#define LED_IP_mReadReg(BaseAddress, RegOffset) Xil_In32((BaseAddress) + (RegOffset))
```

- For this driver, you can see the macros are aliases to the lower level functions **Xil\_Out32( )** and **Xil\_In32( )**
- The macros in this file make up the higher level API of the led\_ip driver.
- If you are writing your own driver for your own IP, you will need to use low level functions like these to read and write from your IP as required. The low level hardware access functions are wrapped in your driver making it easier to use your IP in an Application project.

# IP Drivers – *Xil\_In32 (xil\_io.h/xil\_io.c)*

```
/*
*****
**
* Performs an input operation for a 32-bit memory location by reading from the
* specified address and returning the Value read from that address.
*
* @param   Addr contains the address to perform the input operation at.
*
* @return  The Value read from the specified input address.
*
* @note    None.
*
*****
u32 Xil_In32(INTPTR Addr)
{
    return *(volatile u32 *) Addr;
}
```

# IP Drivers – *Xil\_Out32 (xil\_io.h/xil\_io.c)*

```
/*
*****
**
* Performs an output operation for a 32-bit memory location by writing the
* specified Value to the the specified address.
*
* @param Addr contains the address to perform the output operation at.
* @param Value contains the Value to be output at the specified address.
*
* @return None.
*
* @note None.
*****
void Xil_Out32(INTPTR Addr, u32 Value)
{
    u32 *LocalAddr = (u32 *)Addr;

    *LocalAddr = Value;
}
```

# IP Drivers – SDK ‘Activation’

---

- Select *<project\_name>\_bsp* in the project view pane. Right-click
- Select *Board Support Package Settings*
- Select *Drivers* on the *Overview* pane
- If the *led\_ip* driver has not already been selected, select Generic under the Driver Column for *led\_ip* to access the dropdown menu. From the dropdown menu, select *led\_ip*, and click OK>

# IP Drivers – SDK 'Activation' (cont')

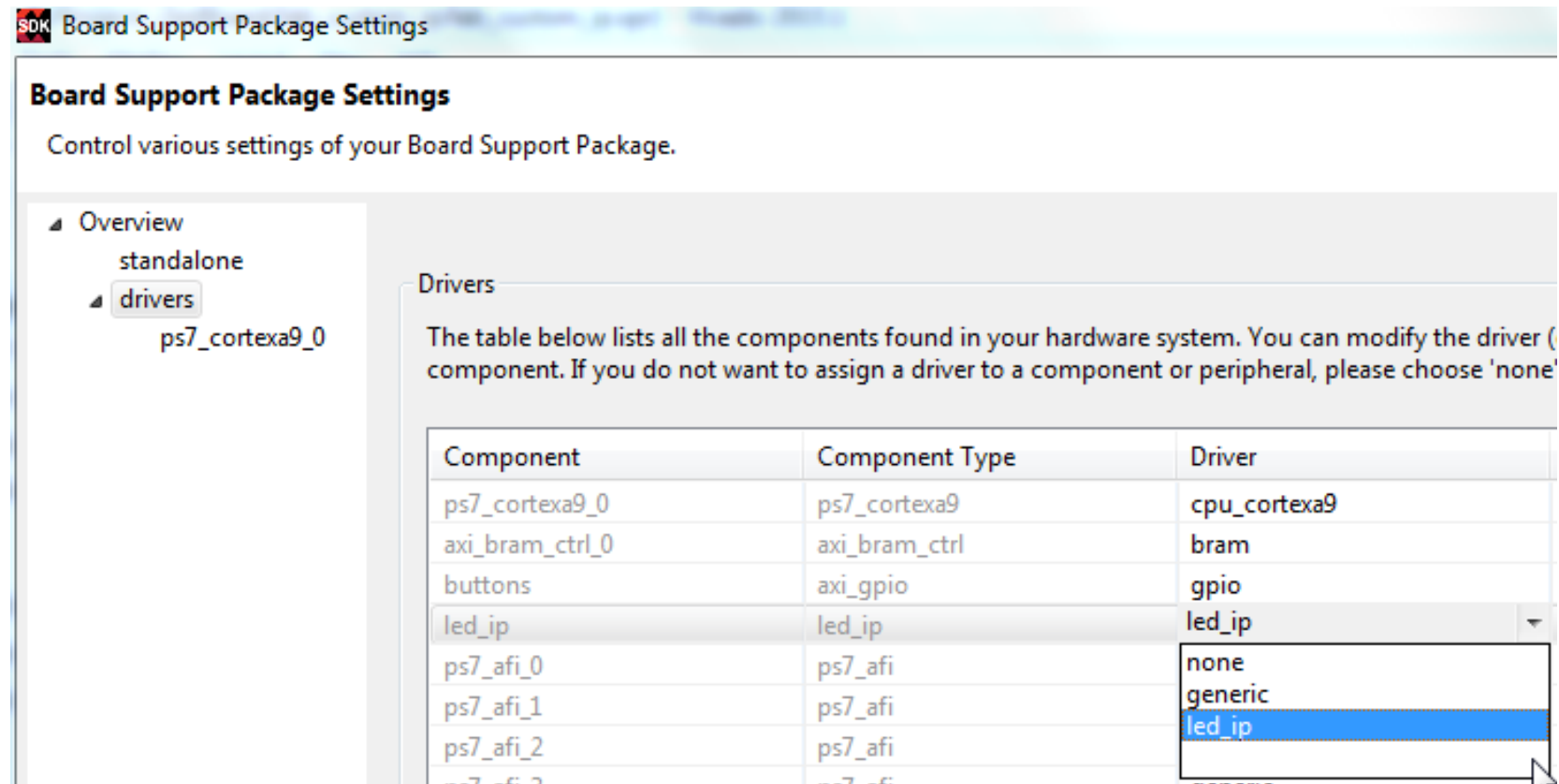

**Board Support Package Settings**

Control various settings of your Board Support Package.

- Overview
  - standalone
    - drivers**
      - ps7\_cortexa9\_0

**Drivers**

The table below lists all the components found in your hardware system. You can modify the driver (component). If you do not want to assign a driver to a component or peripheral, please choose 'none'

Component	Component Type	Driver
ps7_cortexa9_0	ps7_cortexa9	cpu_cortexa9
axi_bram_ctrl_0	axi_bram_ctrl	bram
buttons	axi_gpio	gpio
led_ip	led_ip	led_ip
ps7_afi_0	ps7_afi	none
ps7_afi_1	ps7_afi	generic
ps7_afi_2	ps7_afi	led_ip
ps7_afi_3	ps7_afi	

# System Level Address Map

Address Range	CPU and ACP	AXI_HP	Other Bus Masters <sup>(1)</sup>	Notes
0000_0000 to 0003_FFFF <sup>(2)</sup>	OCM	OCM	OCM	Address not filtered by SCU and OCM is mapped low
	DDR	OCM	OCM	Address filtered by SCU and OCM is mapped low
	DDR			Address filtered by SCU and OCM is not mapped low
				Address not filtered by SCU and OCM is not mapped low
0004_0000 to 0007_FFFF	DDR			Address filtered by SCU
				Address not filtered by SCU
0008_0000 to 000F_FFFF	DDR	DDR	DDR	Address filtered by SCU
		DDR	DDR	Address not filtered by SCU <sup>(3)</sup>
0010_0000 to 3FFF_FFFF	DDR	DDR	DDR	Accessible to all interconnect masters
4000_0000 to 7FFF_FFFF	PL		PL	General Purpose Port #0 to the PL, M_AXI_GP0
8000_0000 to BFFF_FFFF	PL		PL	General Purpose Port #1 to the PL, M_AXI_GP1
E000_0000 to E02F_FFFF	IOP		IOP	I/O Peripheral registers, see <a href="#">Table 4-6</a>
E100_0000 to E5FF_FFFF	SMC		SMC	SMC Memories, see <a href="#">Table 4-5</a>
F800_0000 to F800_0BFF	SLCR		SLCR	SLCR registers, see <a href="#">Table 4-3</a>
F800_1000 to F880_FFFF	PS		PS	PS System registers, see <a href="#">Table 4-7</a>
F890_0000 to F8F0_2FFF	CPU			CPU Private registers, see <a href="#">Table 4-4</a>
FC00_0000 to FDFE_FFFF <sup>(4)</sup>	Quad-SPI		Quad-SPI	Quad-SPI linear address for linear mode
FFFC_0000 to FFFF_FFFF <sup>(2)</sup>	OCM	OCM	OCM	OCM is mapped high
				OCM is not mapped high

# I/O Read Macro

## Read from an Input

```
int switch_s1;  
.  
.  
.  
switch_s1 = *(volatile int *) (0x00011000);
```

```
#define SWITCH_S1_BASE = 0x00011000;  
.  
.  
switch_s1 = *(volatile int *) (SWITCH_S1_BASE);
```

```
#define SWITCH_S1_BASE = 0x00011000;  
#define my_iord(addr) (*(volatile int *) (addr))  
.  
.  
.  
switch_s1 = my_iord(SWITCH_S1_BASE);    //
```

Macro

# I/O Write Macro

## Write to an Output

```
char pattern = 0x01;  
.  
.  
.  
*(0x11000110) = pattern;
```

```
#define LED_L1_BASE = 0x11000110;  
.  
.  
.  
*(LED_L1_BASE) = pattern;
```

```
#define LED_L1_BASE = 0x11000110;  
#define my_iowr(addr, data) (*(int *) (addr) = (data))  
.  
.  
.  
my_iowr(LED_L1_BASE, (int)pattern); //
```

Macro