

Unlocking new chemical space via selective catalysis



Debabrata Maiti
IIT Bombay, Mumbai, India
www.dmaiti.com

dmaiti@iitb.ac.in
+91-9820907155

Key Research Areas

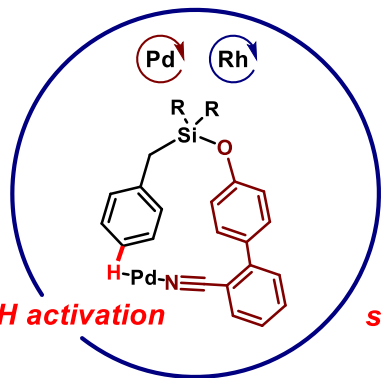

sp^2 C-H activation

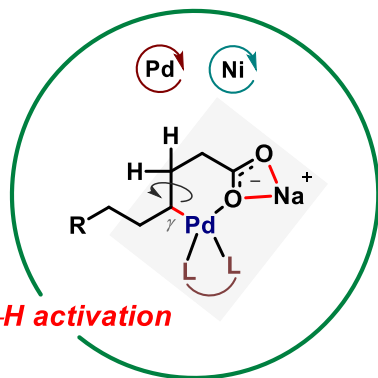

sp^3 C-H activation

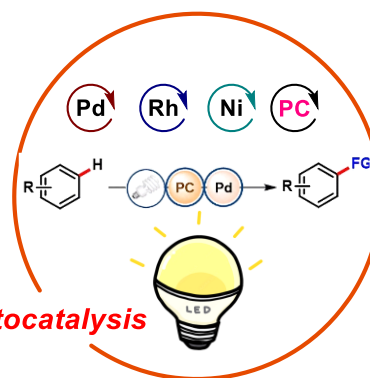

Photocatalysis

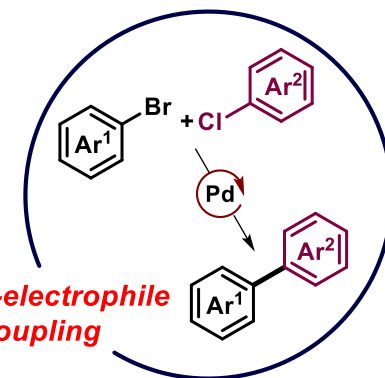

Cross-electrophile coupling

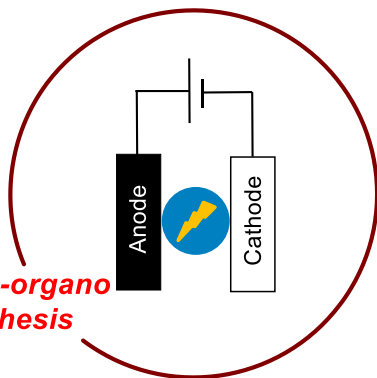

Electro-organo synthesis

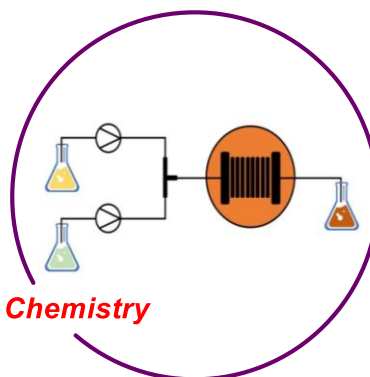

Flow Chemistry

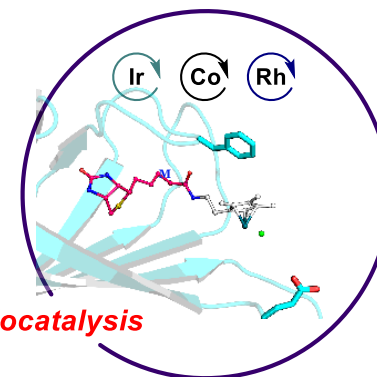

Biocatalysis

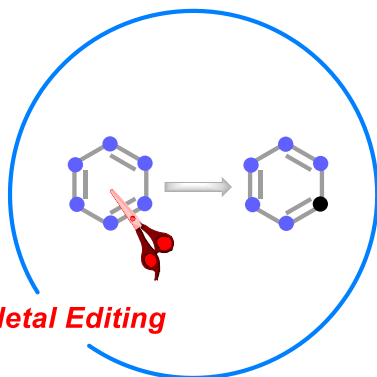

Skeletal Editing

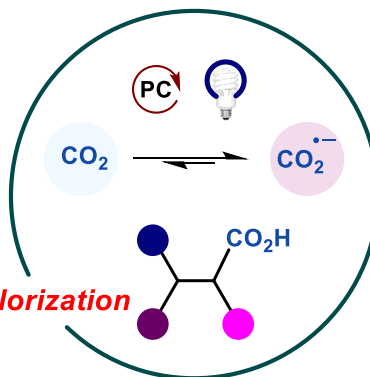

CO₂ valorization

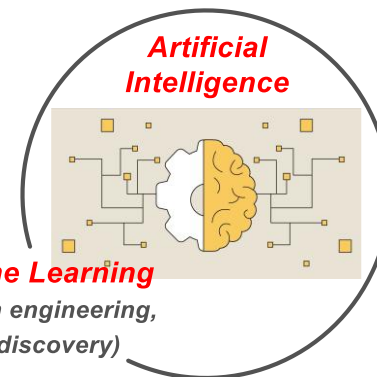

Artificial Intelligence

Machine Learning
(reaction engineering,
drug discovery)

Directing scaffolds controls LSF

meta-C-H functionalization

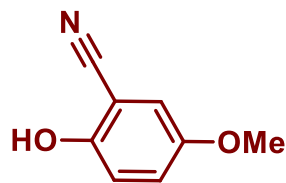
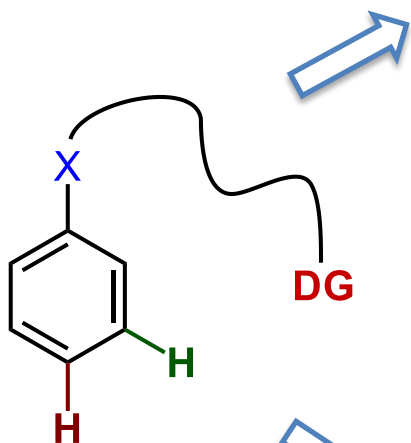

SIGMA-ALDRICH

Maiti-Bera-Modak Auxiliary
Catalogue number 798193

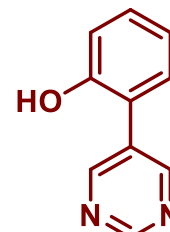
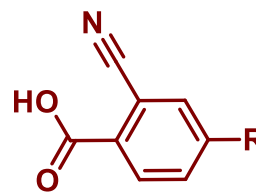
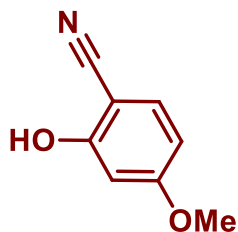

SIGMA-ALDRICH

Maiti-Bag-Dutta Auxiliary
Catalogue number 930083

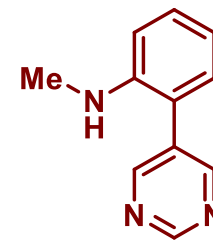

para-C-H functionalization

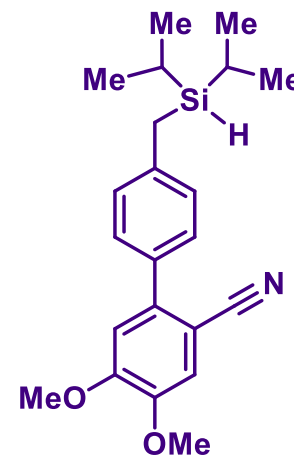
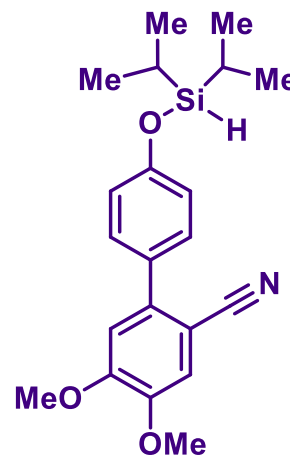
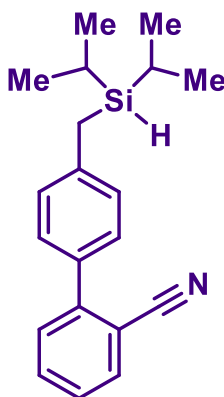
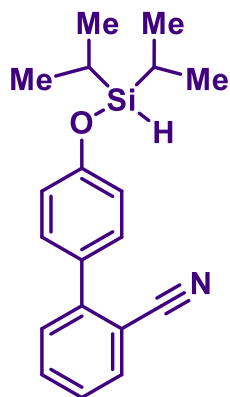

Maiti-Patra-Bag Auxiliary
TCI

Low energetic C–H activation step: **Reversible?**

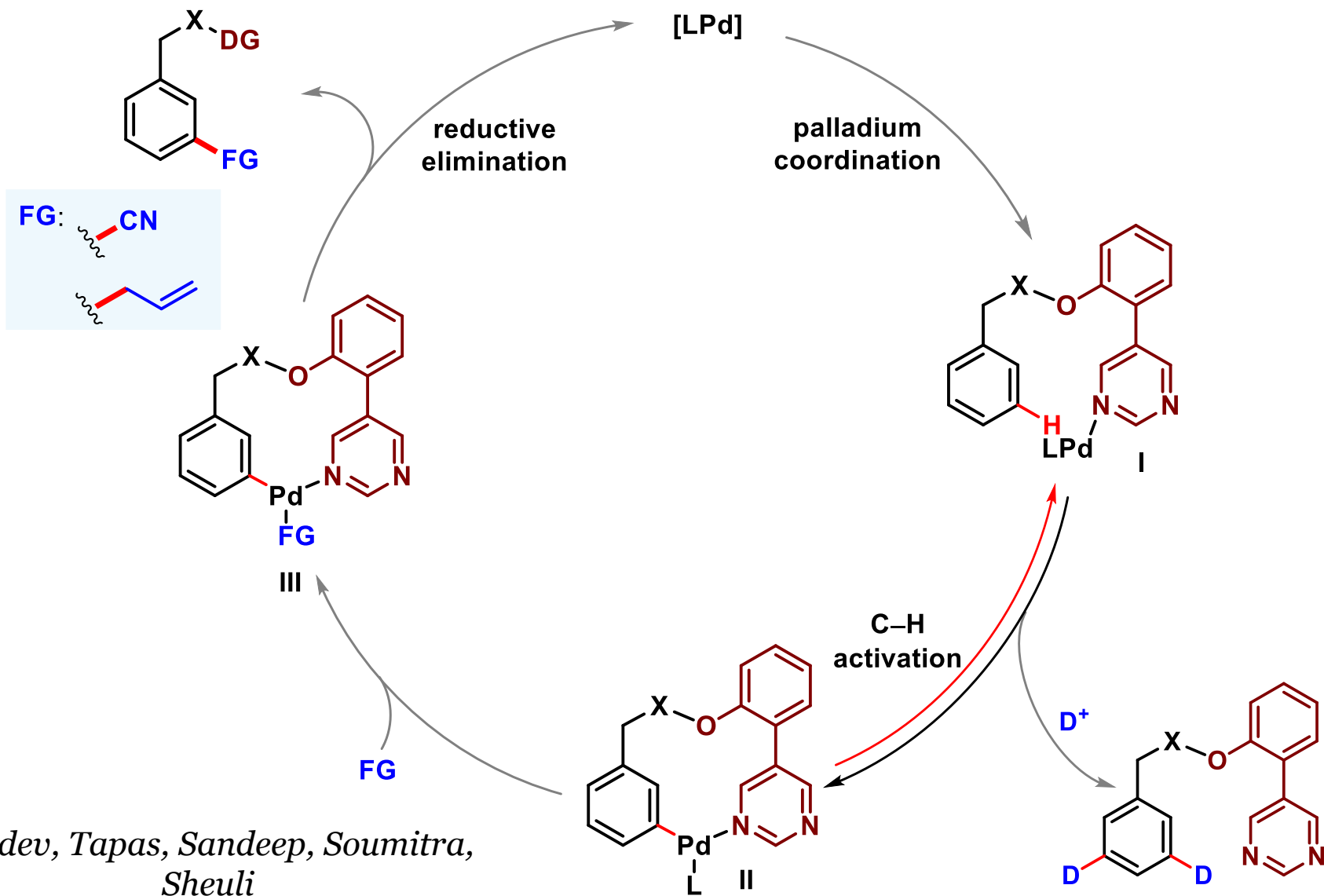

Mechanism of *para*-C–H functionalisation

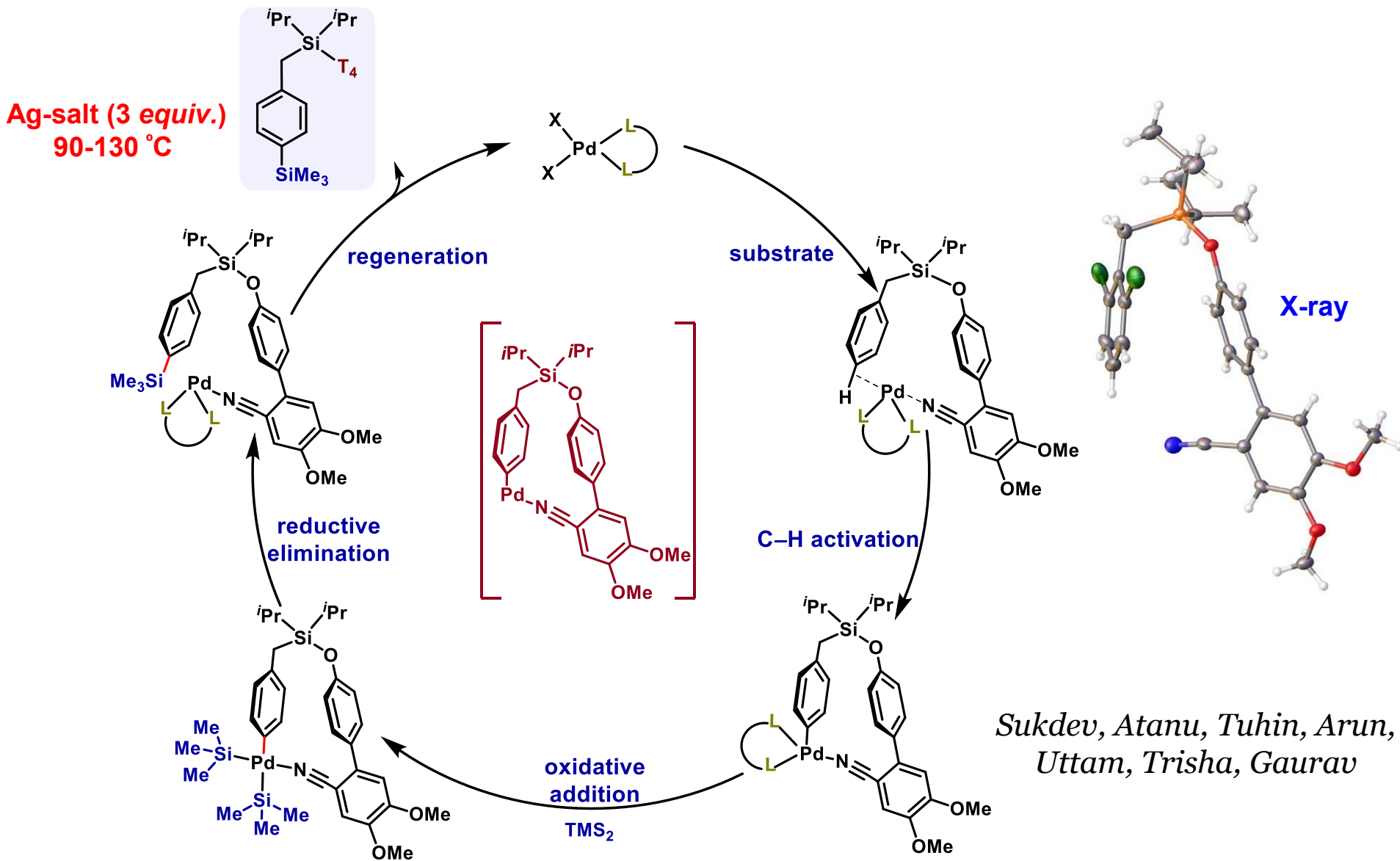

Evolution of transient approach

Covalent DG Approach



- Rigid backbone to maintain distance and geometry
- Extra steps for installation and removal of DG
- High molecular weight scaffold

Transient DG Approach



- Reversibly attachable-and-detachable DG
- One pot synthesis

Cytochrome P450 mediated hydroxylation

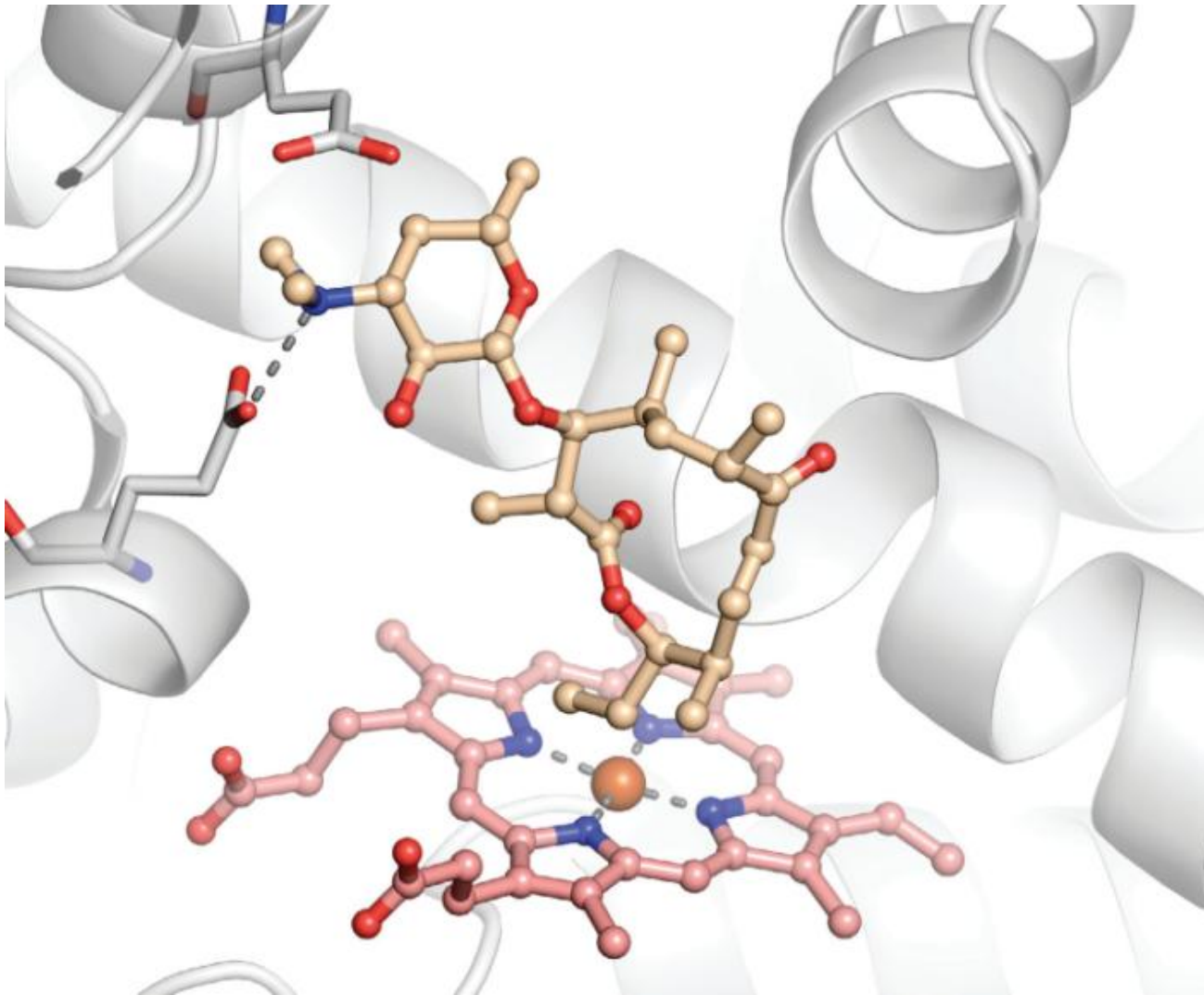

Introducing catalytic anionic ligand

Previous approach
with covalent DG

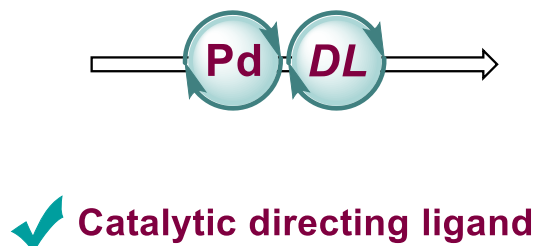
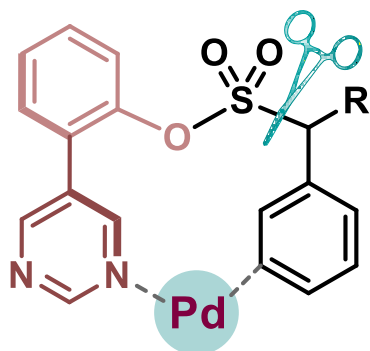

Non-covalent approach
with organic salts

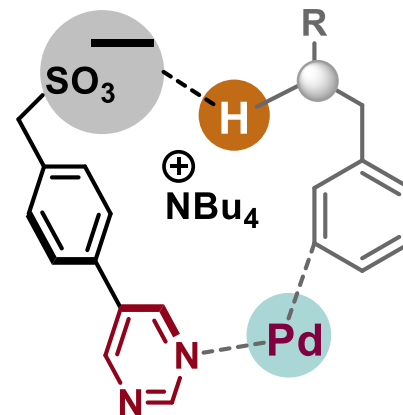

- ✓ Anionic ligand directed distal activation
- ✓ Pd-catalysed *meta*-olefination of amines
- ✓ Non-covalent interaction assisted *meta*-olefination

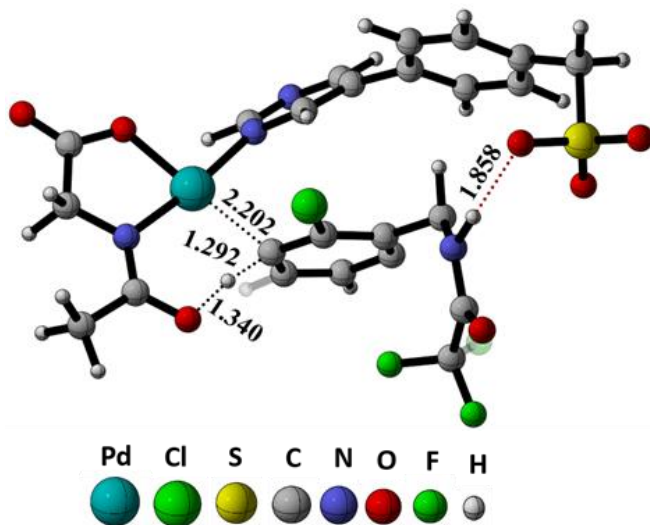

Nupur



Soumya

Substrate-ligand two fold **H-bonding** interaction

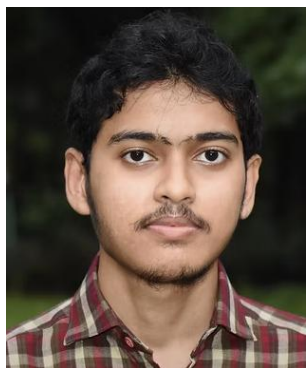
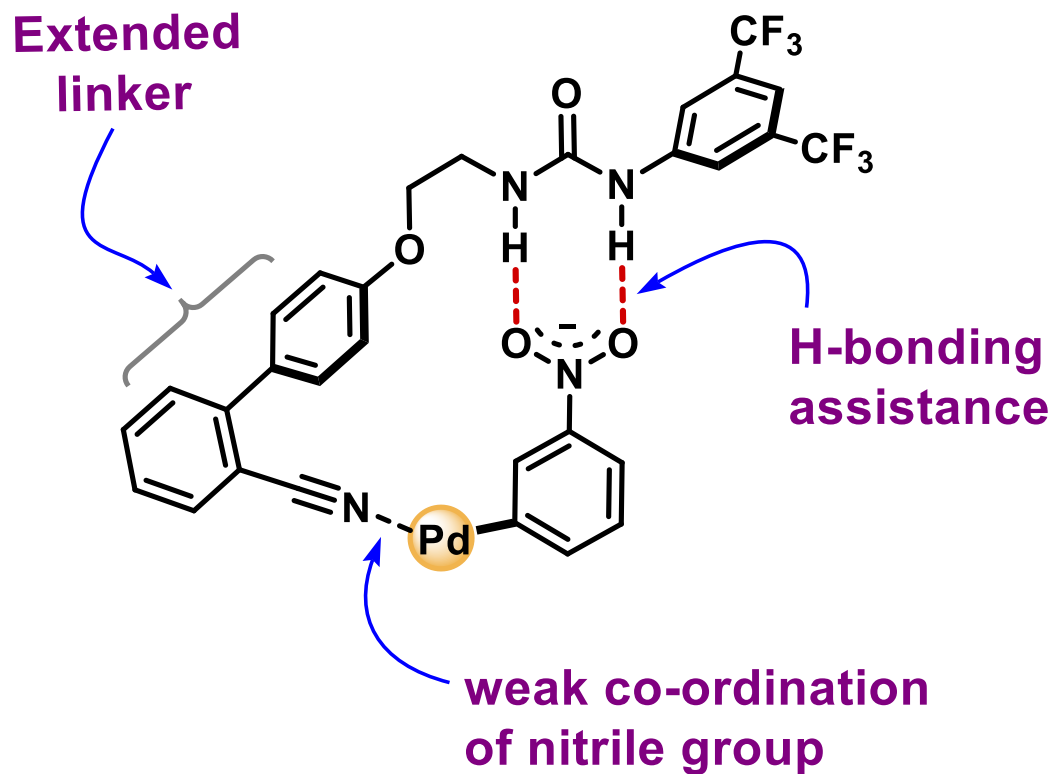

Bishal

- ✓ *H-bonding interaction guides regioselectivity*
- ✓ *Meta-C-H activation of nitroarenes*

Photocatalysis with Pd @ RT, oxidant free

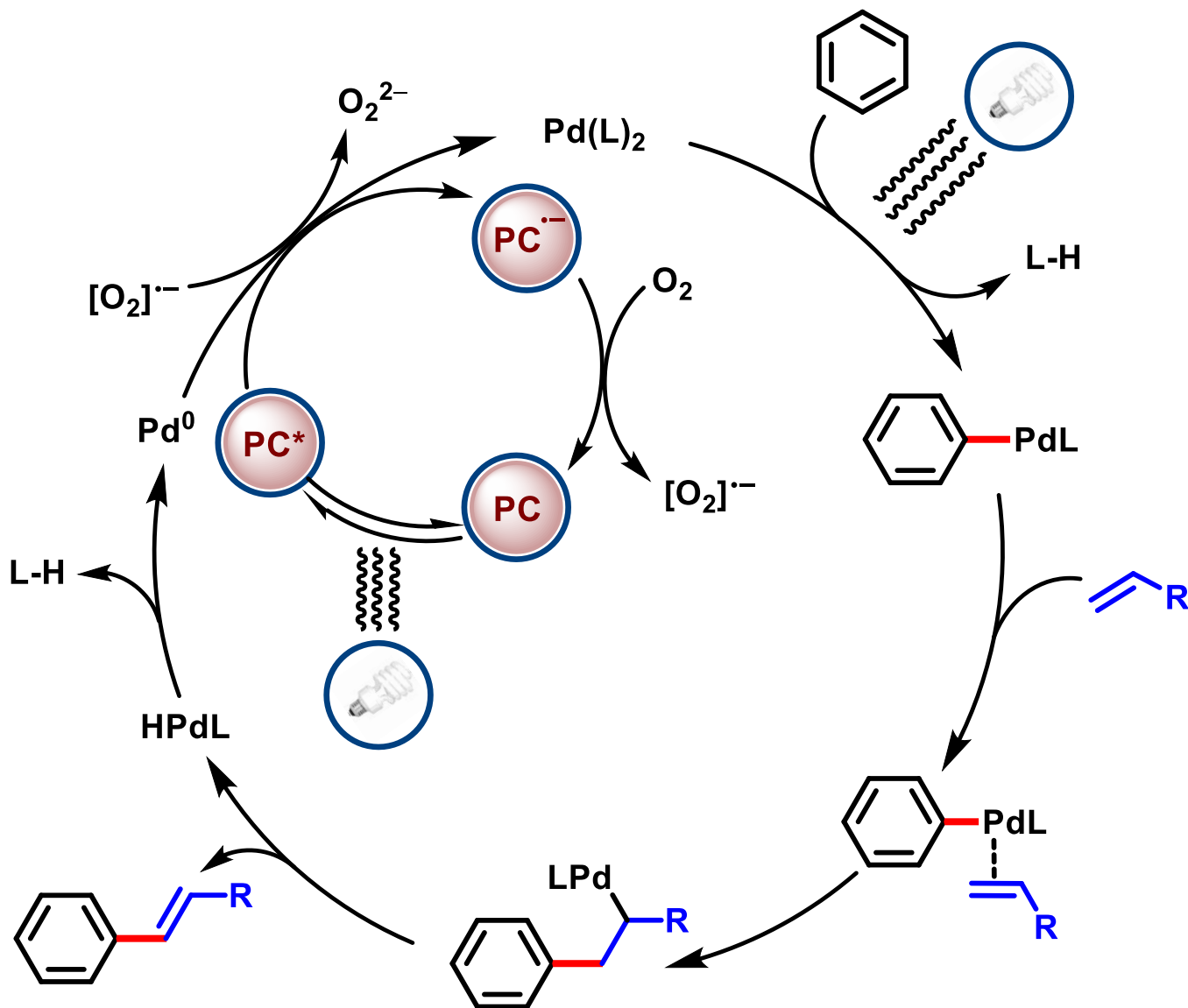

Superior photocatalytic performances

Thermal approach

Our Photocatalytic approach

Thermal approach

Our Photocatalytic approach

AgOAc (2 equiv.)

No external oxidant

100 °C

RT

Yu and coworkers
Nature **2017**, 551, 490



Argha

Srimanta

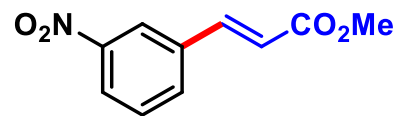

(*m/p* = 14.1/1.0)

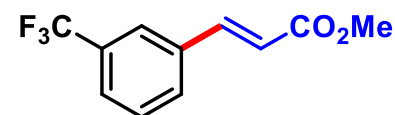

69%, (*m/p* = 3.3/1.0)

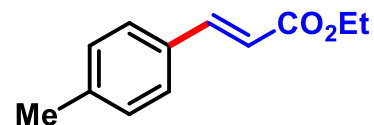

(*o/m/p* = 1.0/12.2/13.8)

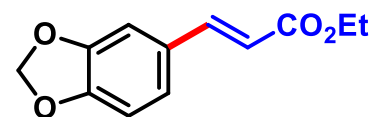

(β/α = 1.8/1.0)

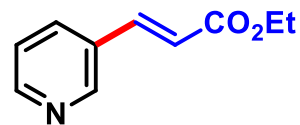

(*C-3/C-2/C-4* = 12/1/1)

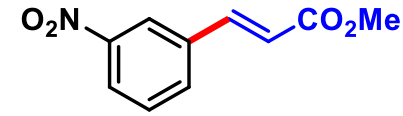

exclusive

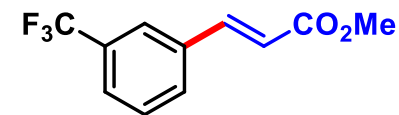

exclusive

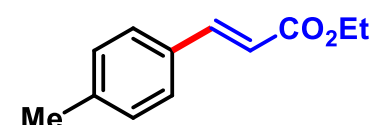

exclusive

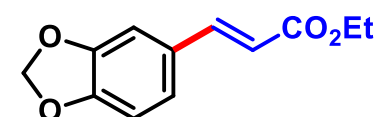

exclusive

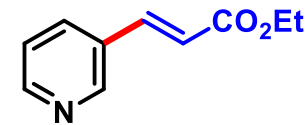

exclusive

Theory corroborates with experimental data

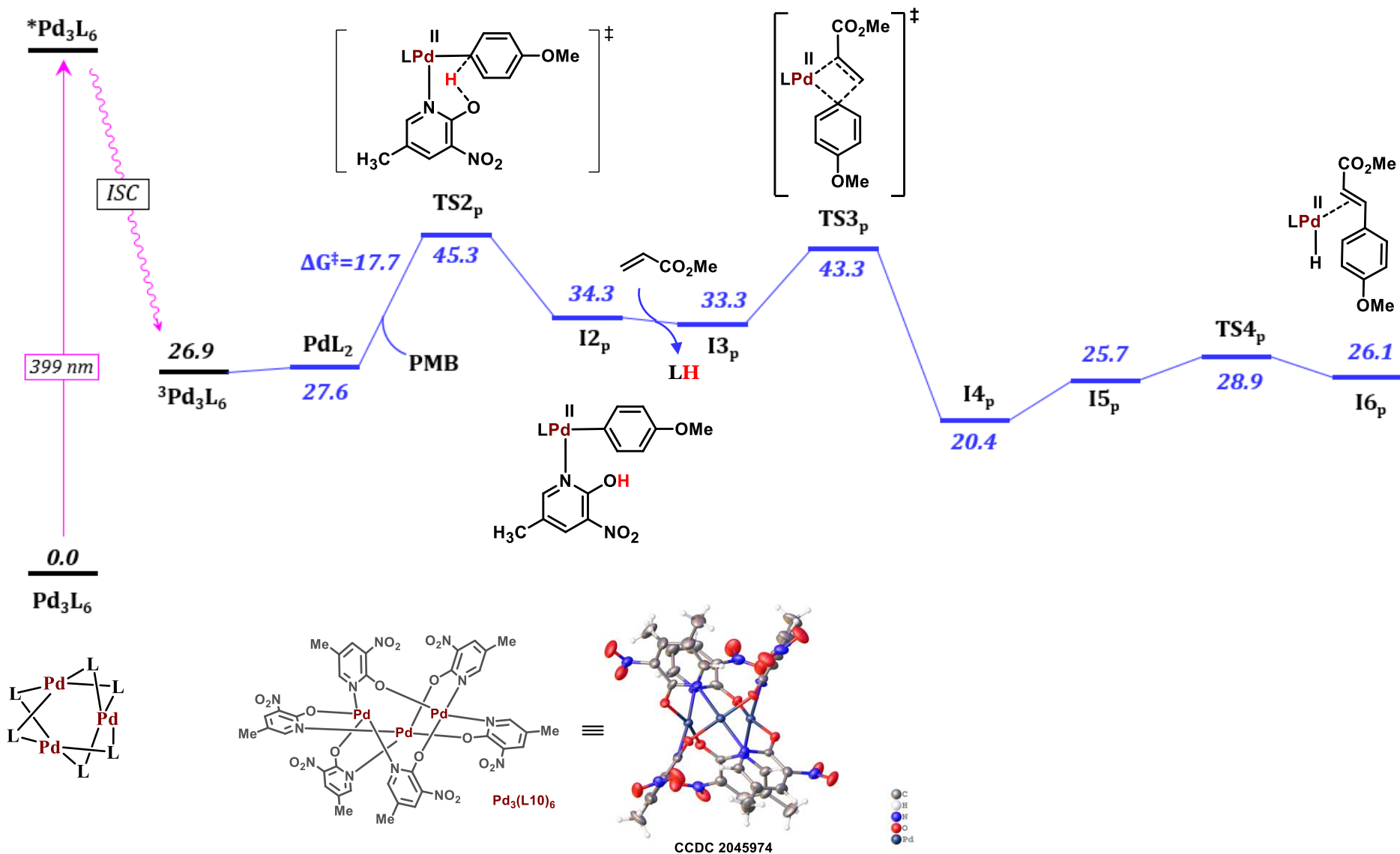

Deuteration and Tritiation of Pharmaceuticals

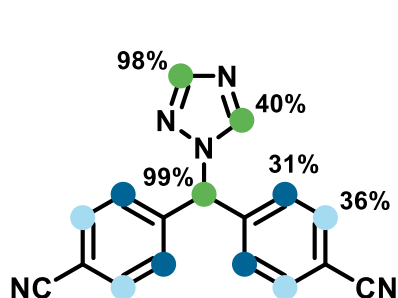

6[²H], 78%
Letrozole
- D/molecule

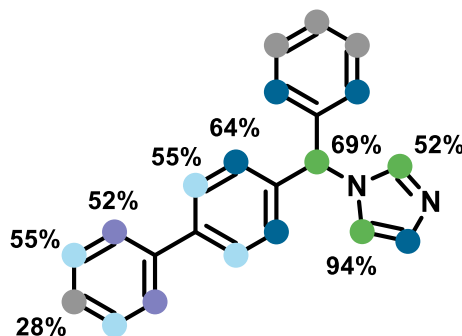

7[²H], 88%
Bifonazole
9.71 D/molecule

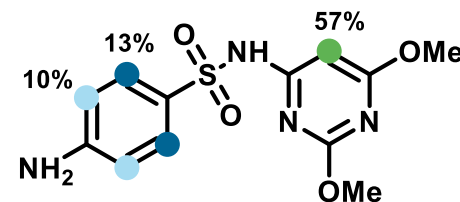

8[²H], 73%
Sulfadimethoxine
1.03 D/molecule

Tritium labelling

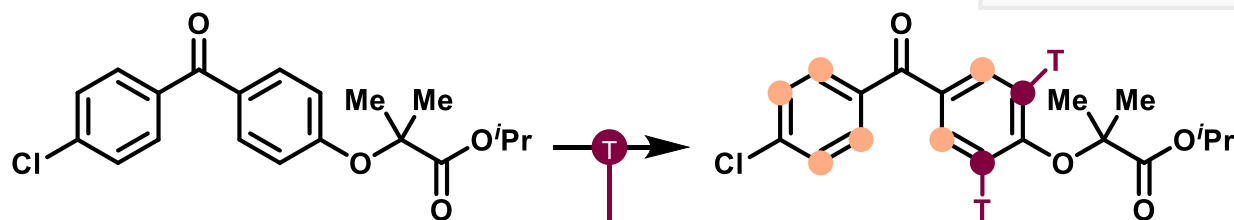

Fenofibrate 14

T-Fenofibrate, 14[³H]

Tritiation by HTO

molar activity
259 GBq mol⁻¹

radiochemical purity
>98%

in situ preparation of HTO (~ 4 Ci) by reduction of Pt₂O in TFT/Dioxane



Dr. Grégory Pieters
CEA Paris-Saclay, France

Achiral metal, *chiral* cavity

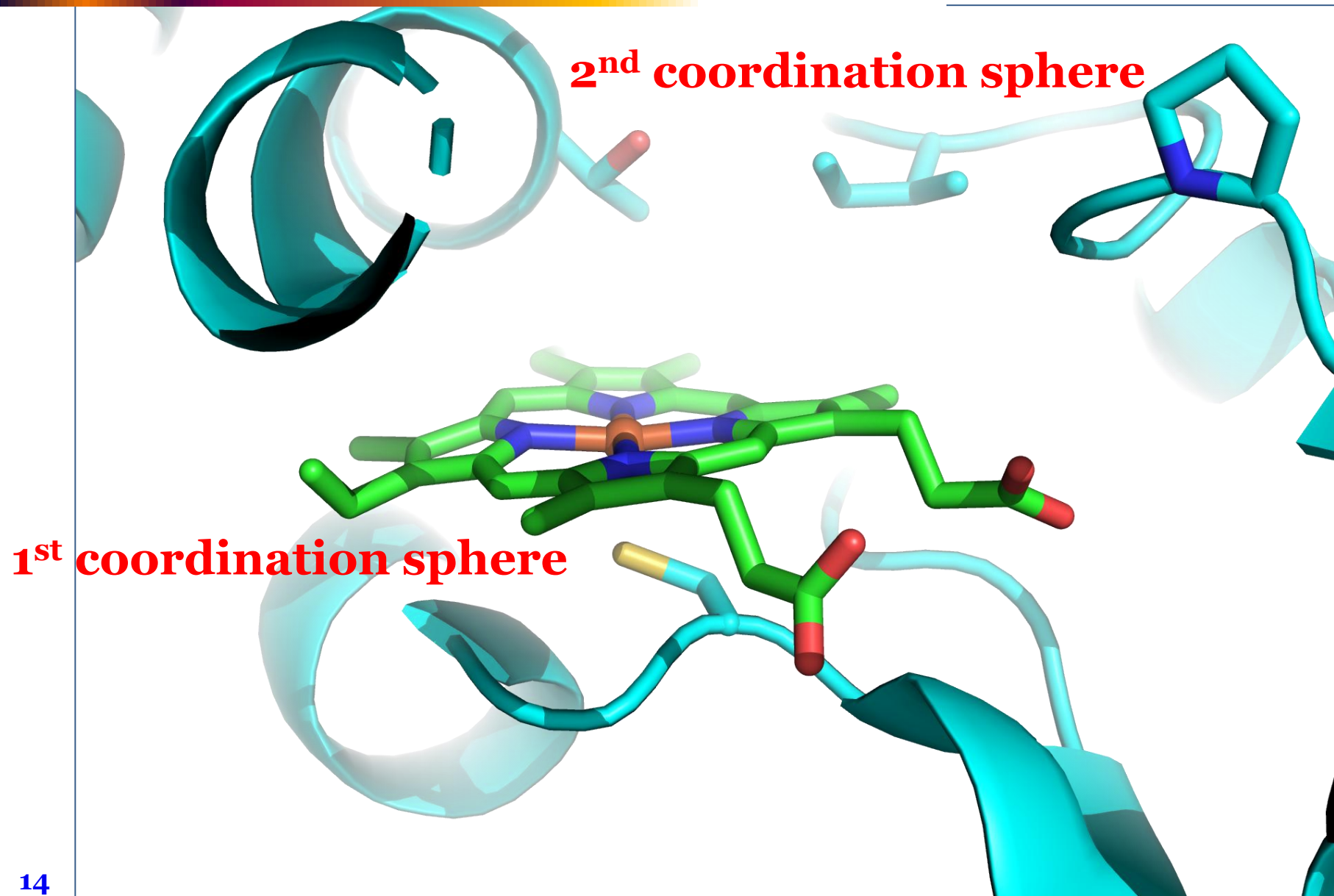

Metalloenzyme's active site

Artificial metalloenzyme (*hybrid platform*)

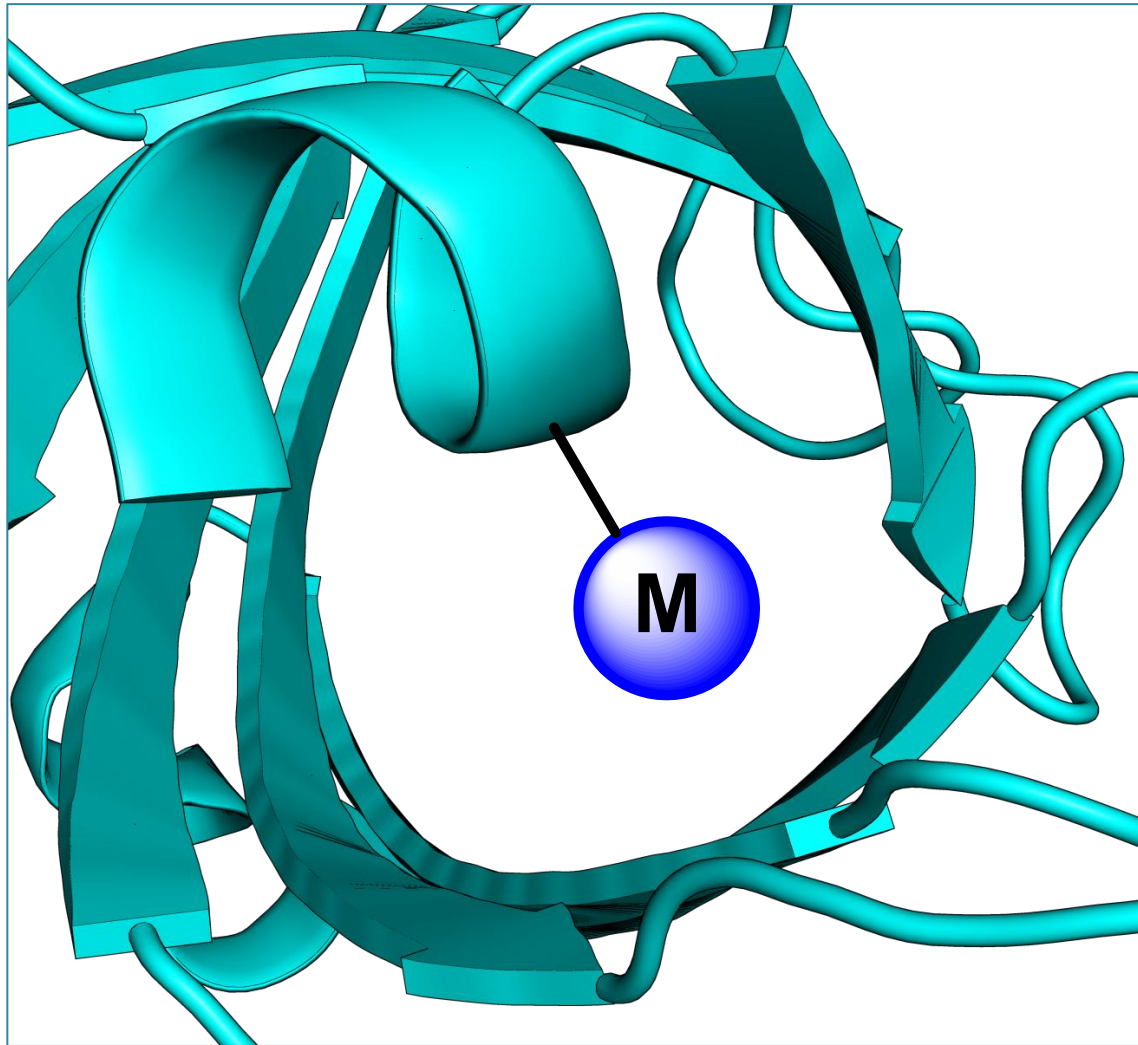

Mutation is the *way forward*



Prasun



Hirak



Nandita

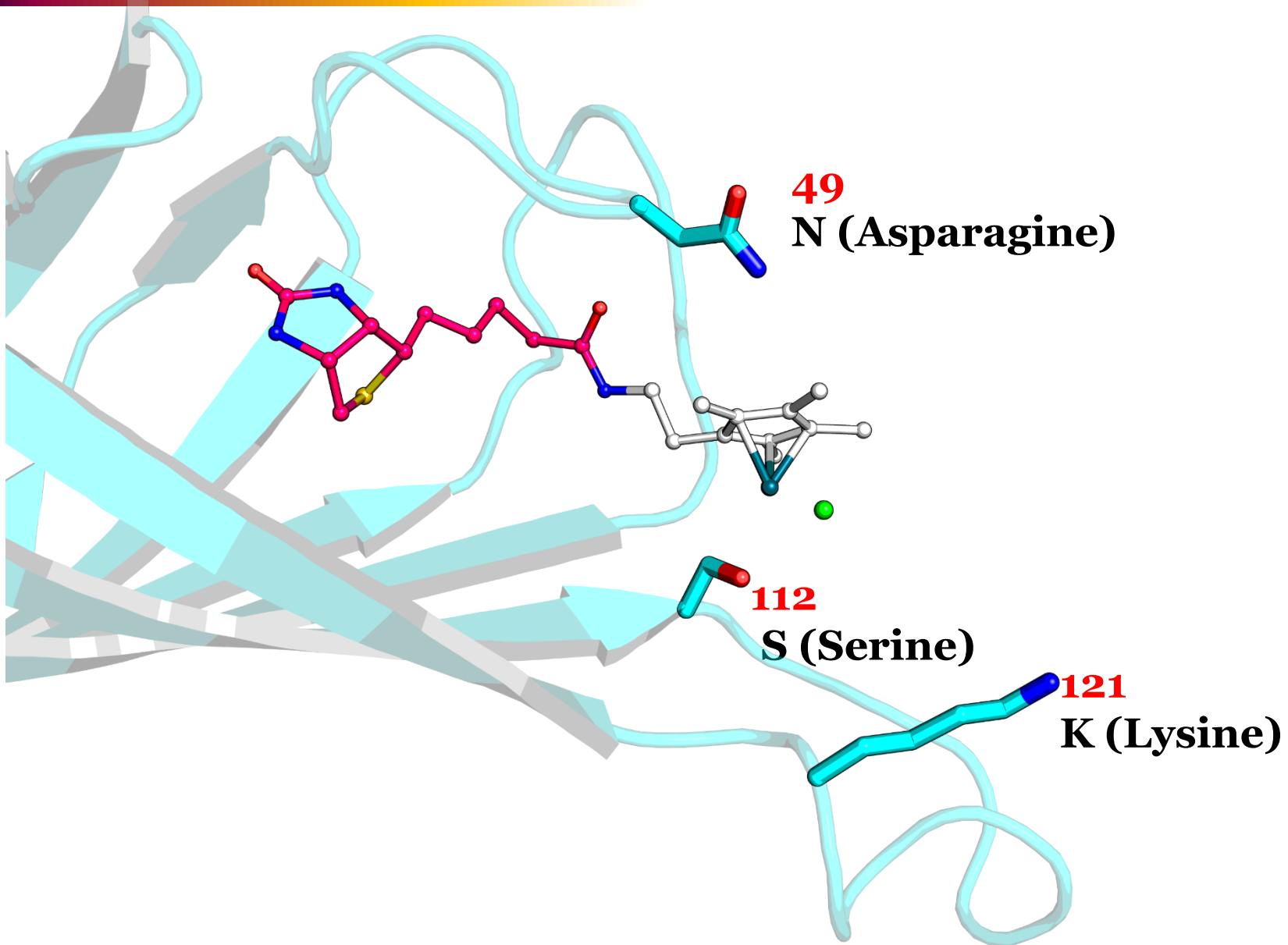

(R)-Selectivity by site directed mutagenesis

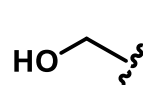
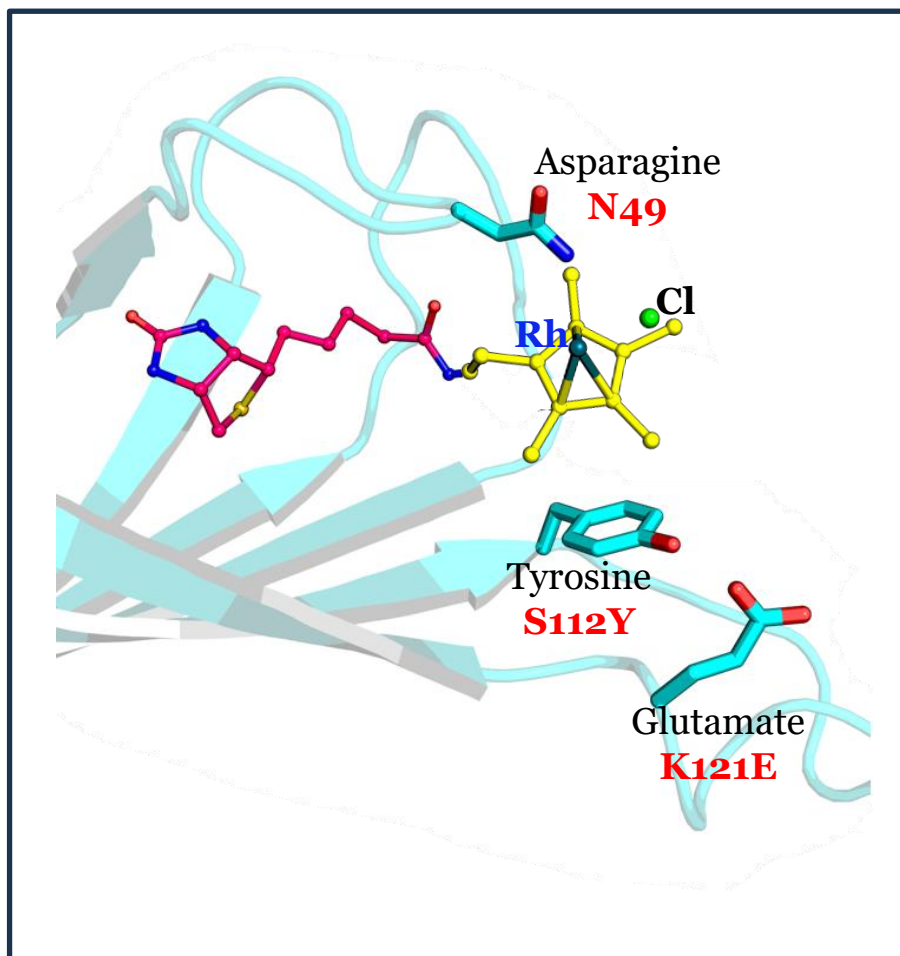
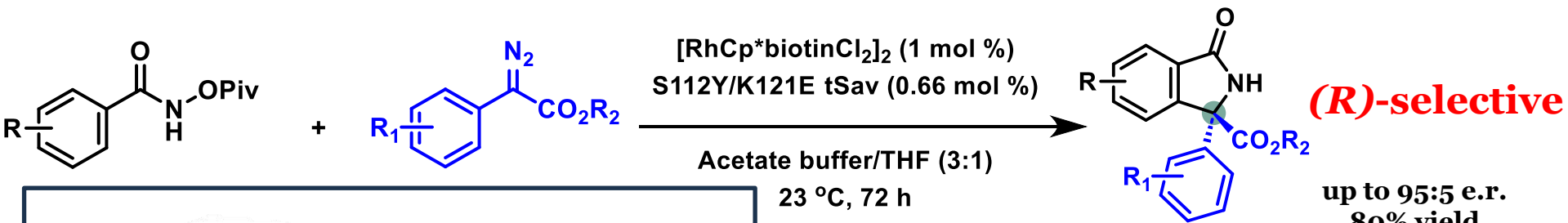

Serine (S112)

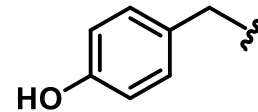

Tyrosine (S112Y)

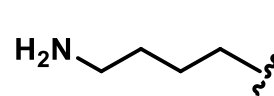

Lysine (K121)

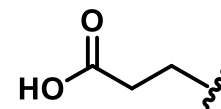

**Glutamic acid
(K121E)**

ArMs catalyzed Photo redox reactions

Photoinduced iridium artificial metalloenzymes mediated indolone synthesis

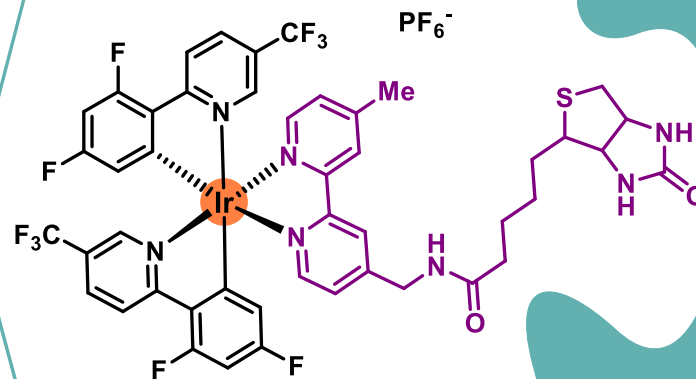
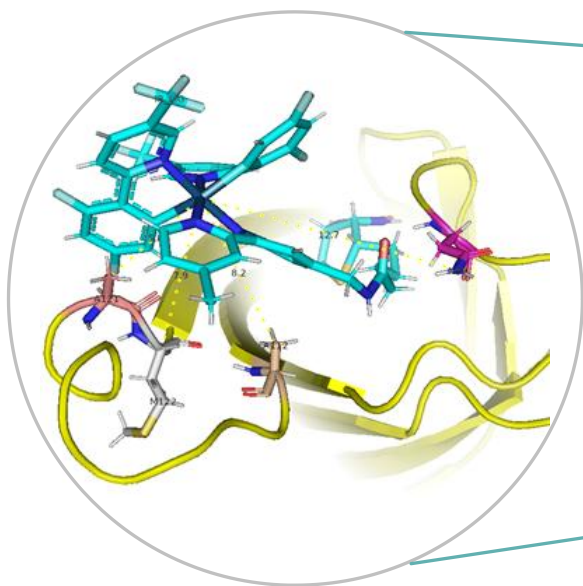
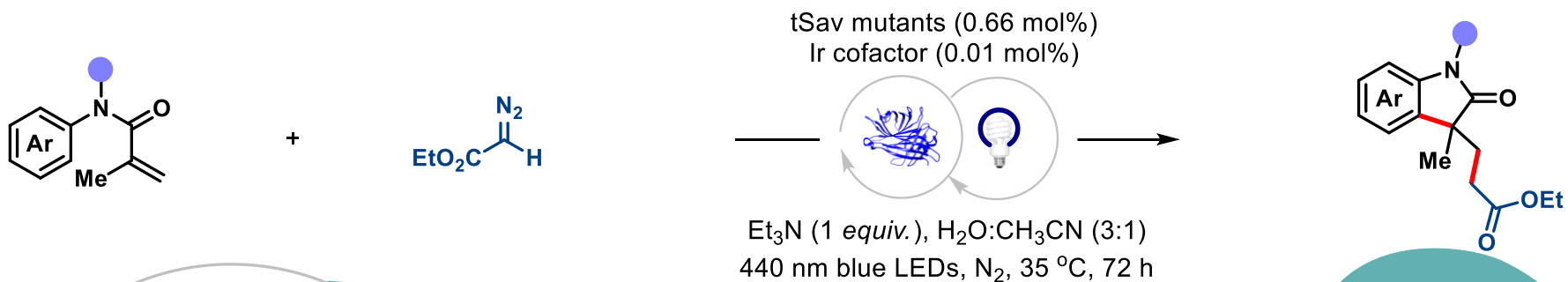

Biotinylated iridium co-factor into streptavidin

ArMs catalyzed Photo redox reactions

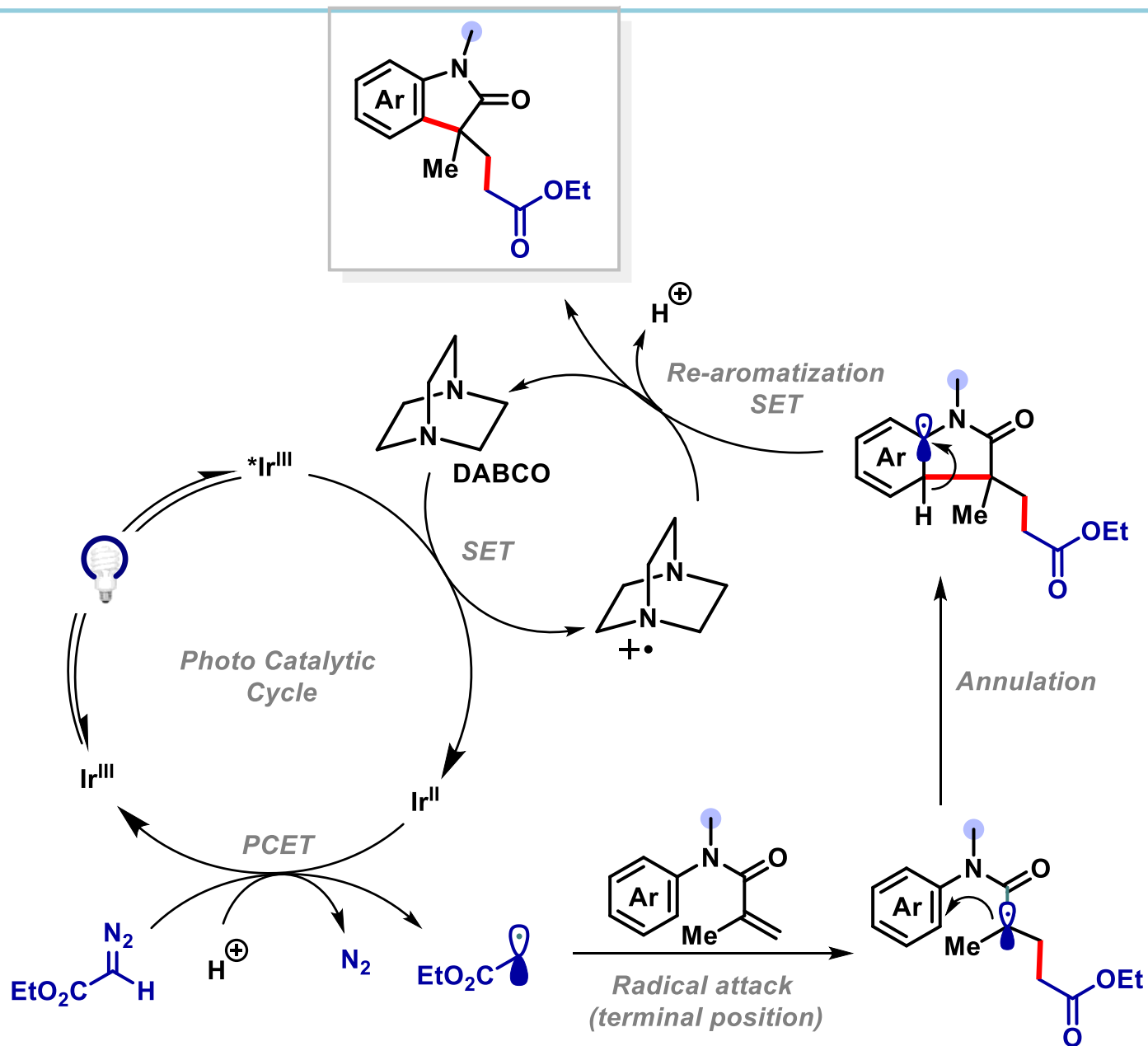

Cross-coupling leads the way...

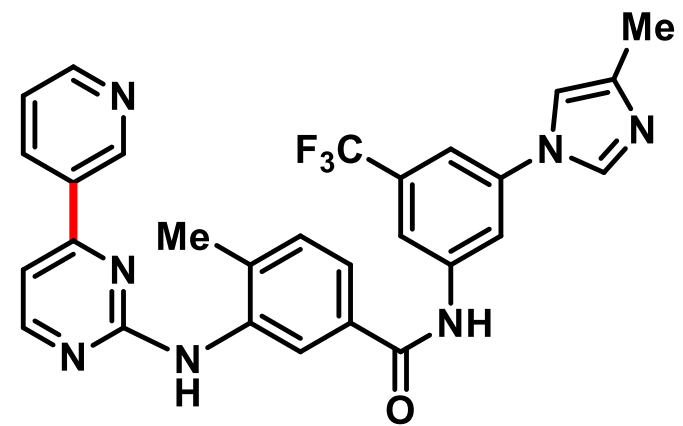
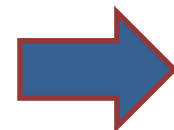
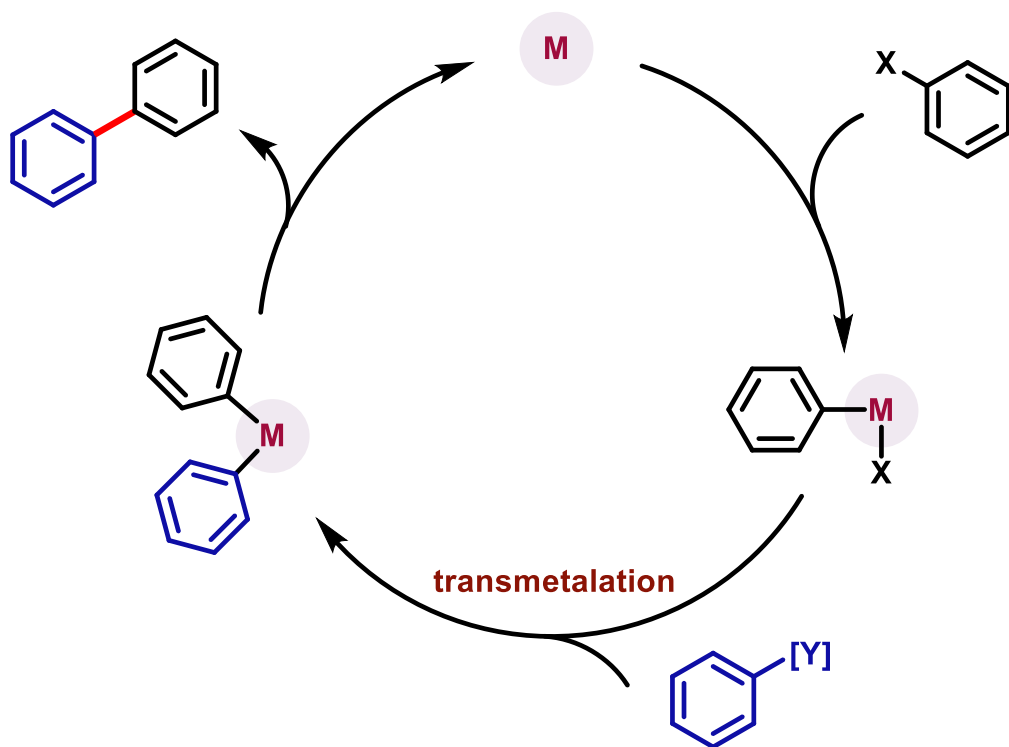
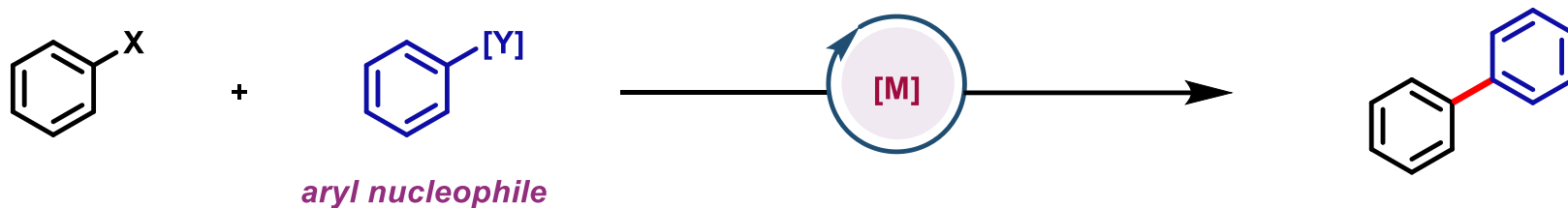

Tasigna
\$1.923 Billion
Hematology

Breaking barriers in cross-electrophile coupling

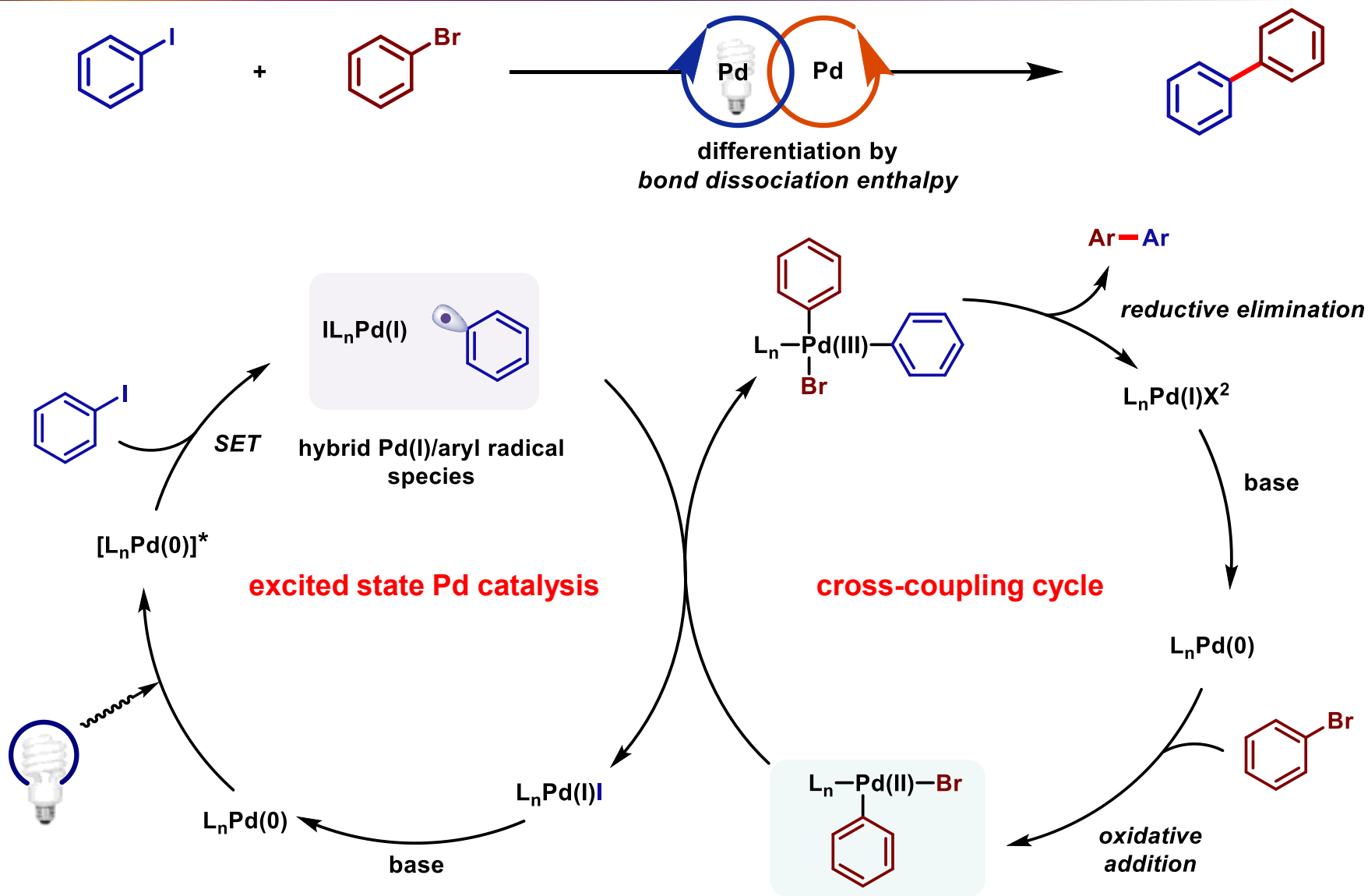

2,4-di-NMe₂ stabilises Pd⁰

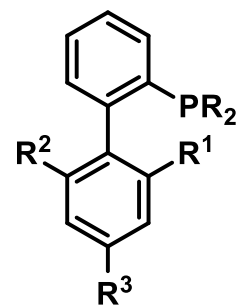

stereoelectronic modulation

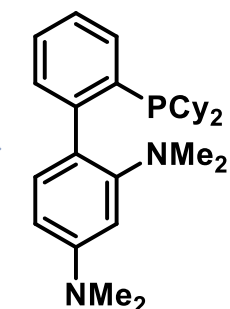

SudipPhos

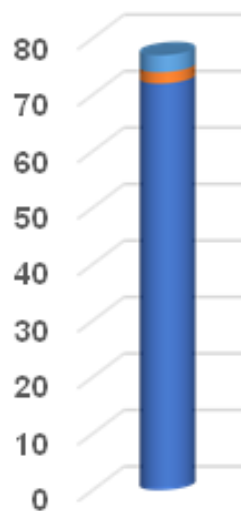
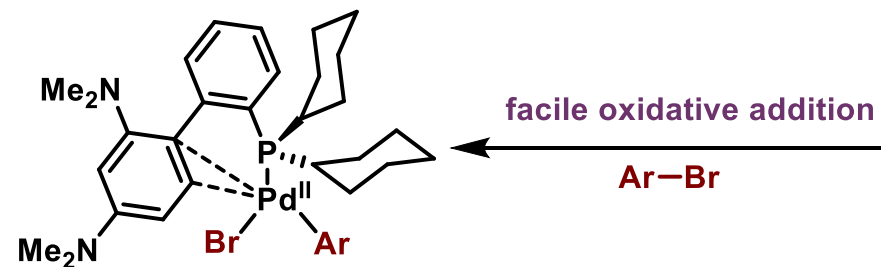
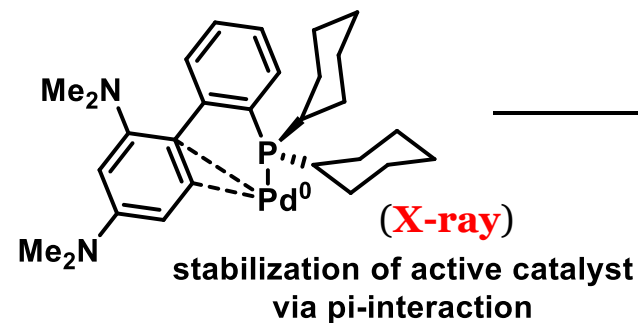

SudipPhos

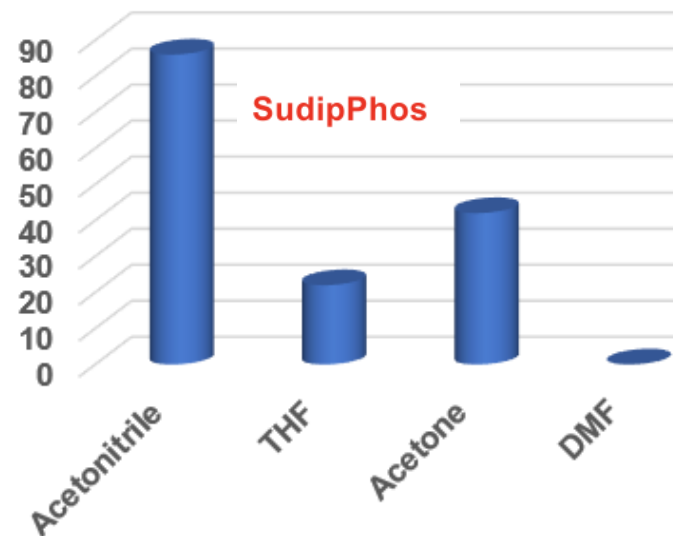

SudipPhos

Replacing expensive boronic acids by halides

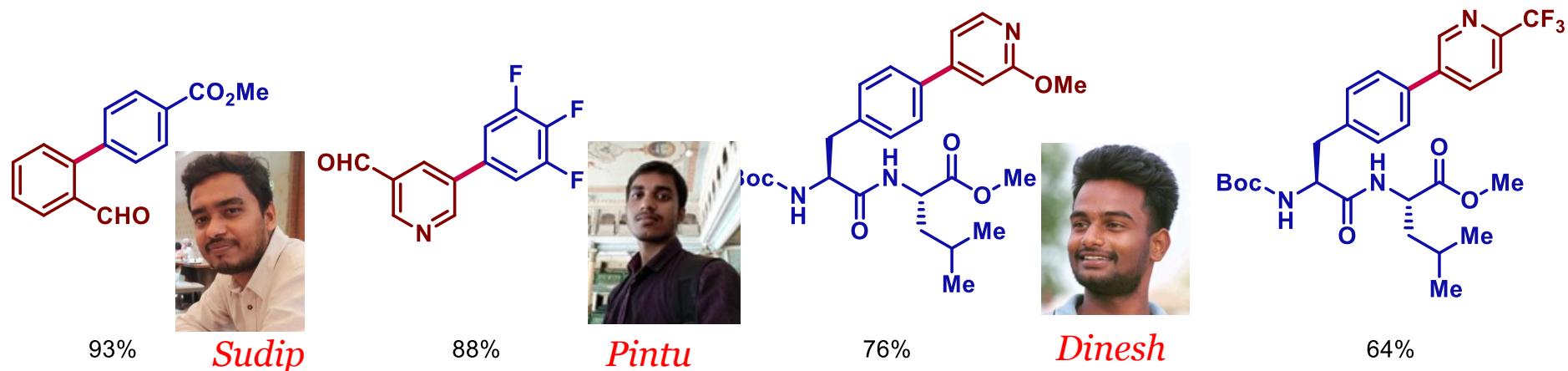
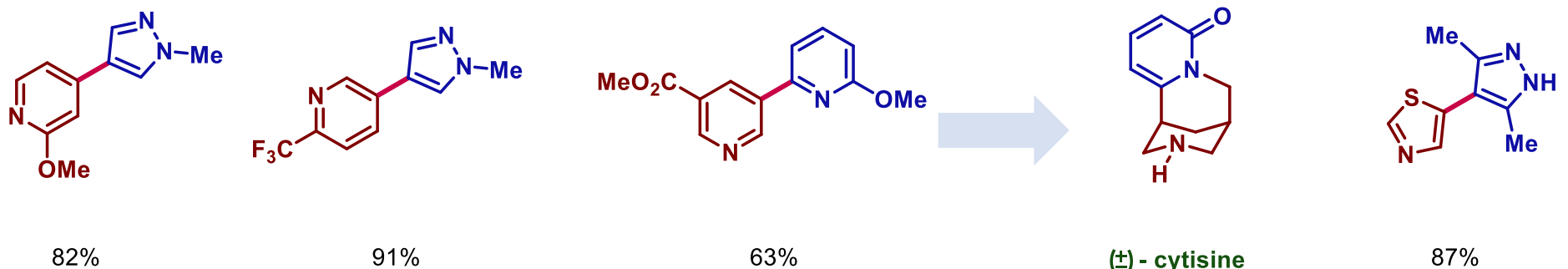
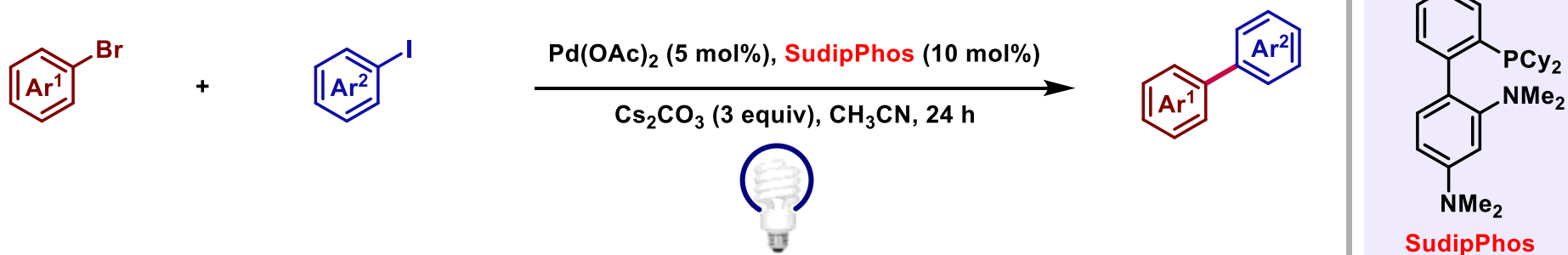

XEC reaction *via* continuous photo-flow

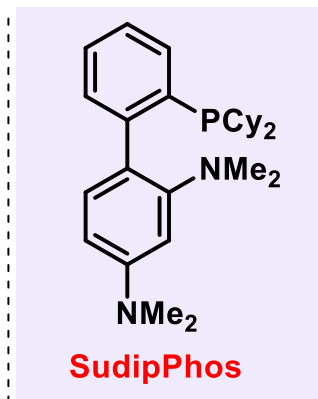
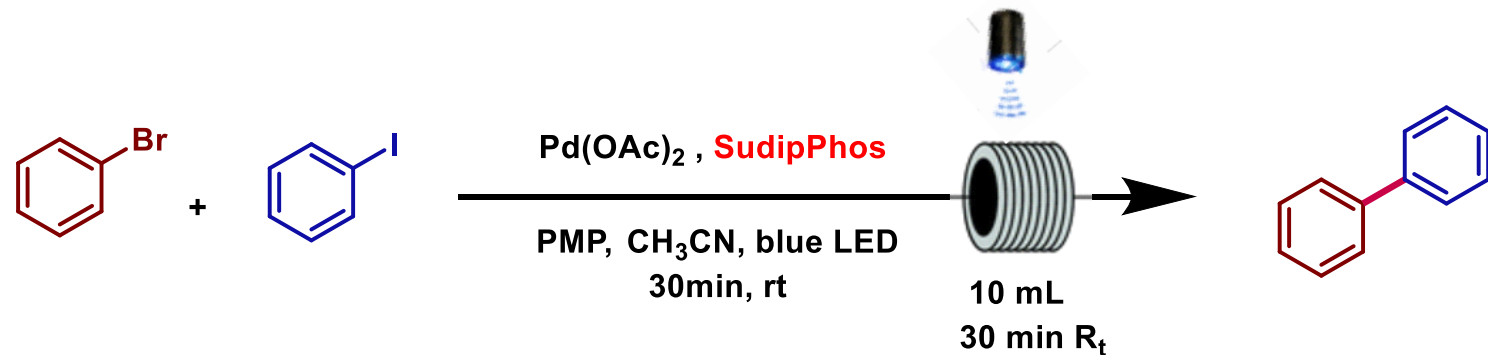

Pd(OAc)_2
SudipPhos

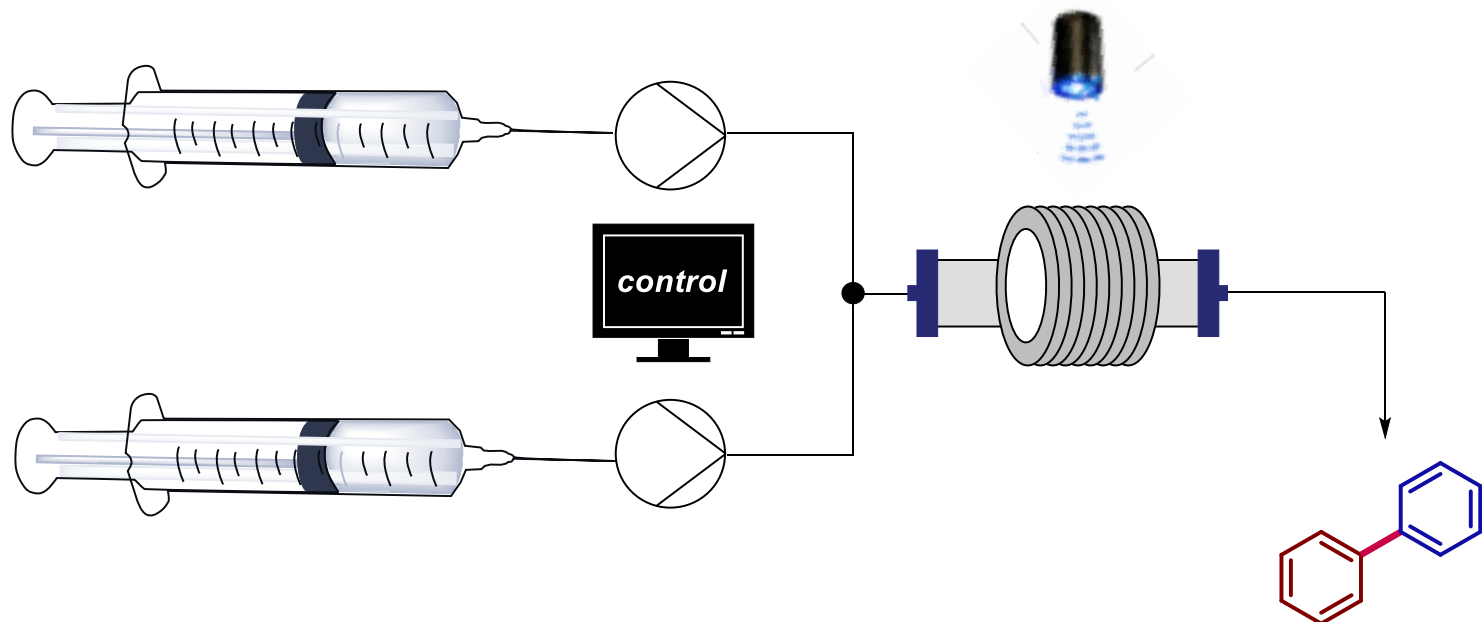
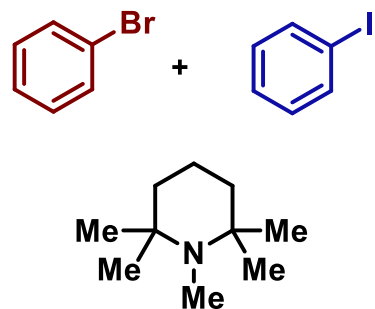

Industrial scale application

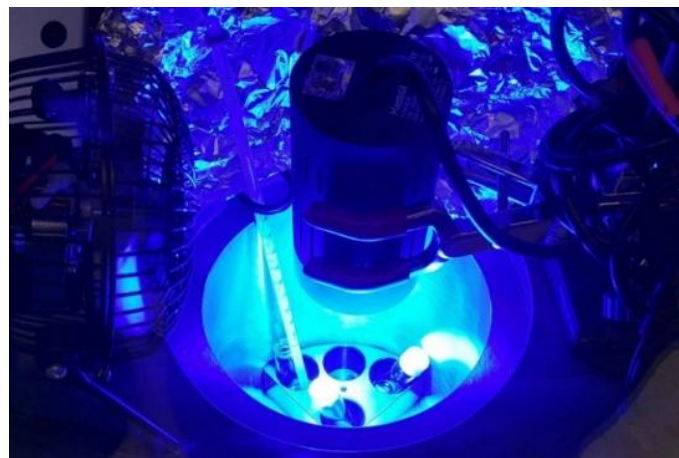

Light set-up in laboratory
440 nm, 34 W LEDs (for trial on 1 kg scale)

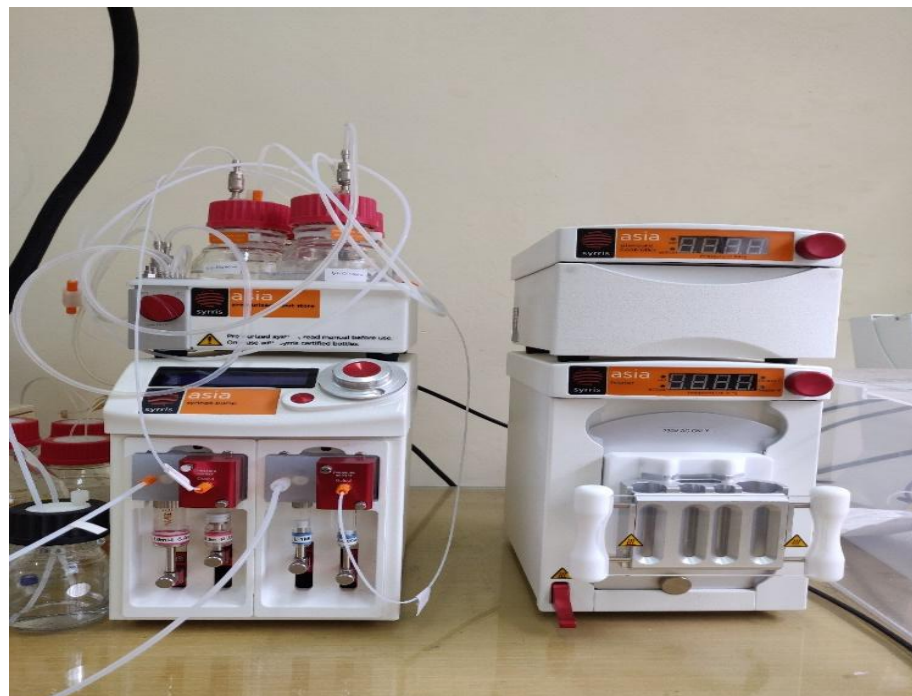

Thank You @ICOPP

Funding Agencies – BARC, DST, ANRF, CSIR, DRDO, ISRO,
ACTREC, Industry Partners

Collaborators, students



Unlocking new chemical space via selective catalysis



Debabrata Maiti

IIT Bombay, Mumbai, India

www.dmaiti.com

dmaiti@iitb.ac.in

+91-9820907155

Use of industrial waste **carbon dioxide** and **olefins**



CO₂



*Development of strategies for fixing CO₂
in unsaturated hydrocarbon*

AXILOR
WHERE INNOVATION MEETS EXECUTION

CO₂

+

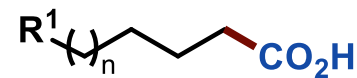
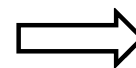
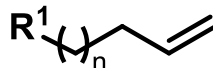

oil industry (mainly from fume)

petroleum waste olefin

Kilogram scale

Terminal carboxylic acid containing **pharmaceuticals**



+

Olefin

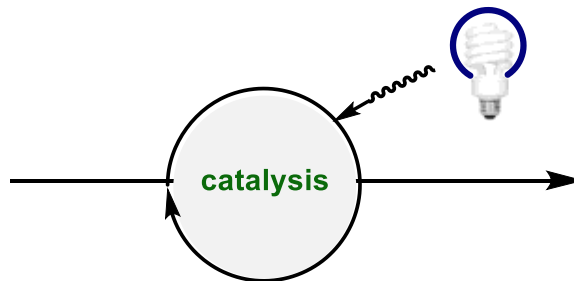

Medicines

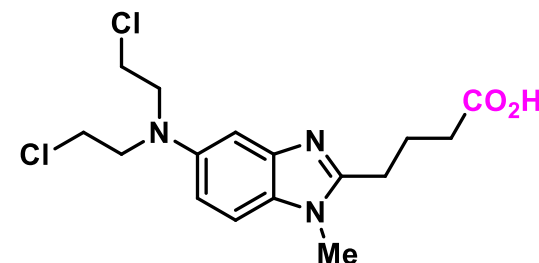
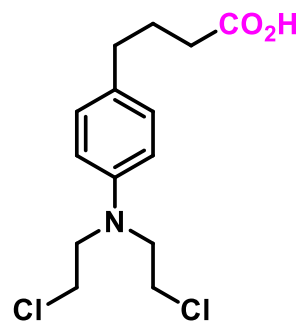
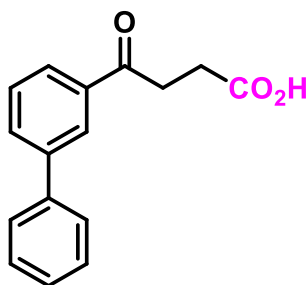
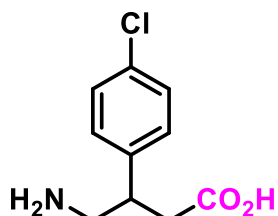
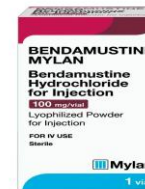

Baclofen

relaxes muscles

Fenbufen

nonsteroidal
anti-inflammatory drug

Chlorambucil

chronic lymphocytic
leukemia

Bendamustine

chronic lymphocytic leukemia

Challenges of hydrocarboxylation reaction

- challenges associated with single electron reduction of CO_2

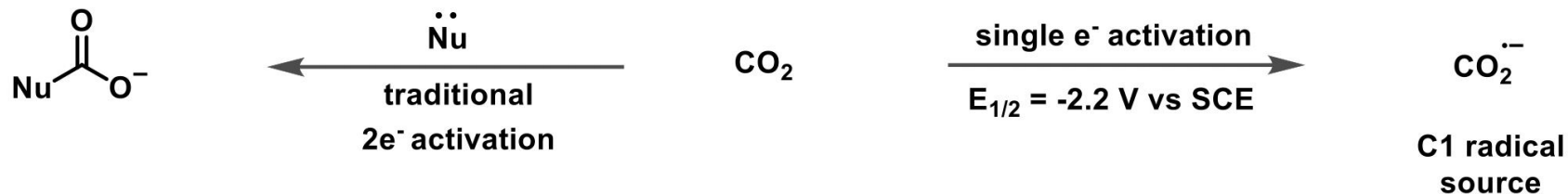

- difficulties of valorization of $\text{CO}_2^{\cdot-}$

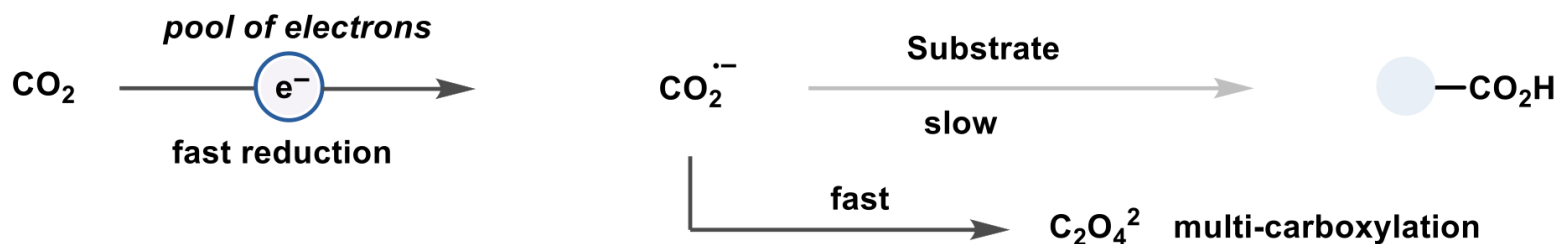

- our approach: A H^- and H^\cdot atom transfer synergy for selective carboxylation

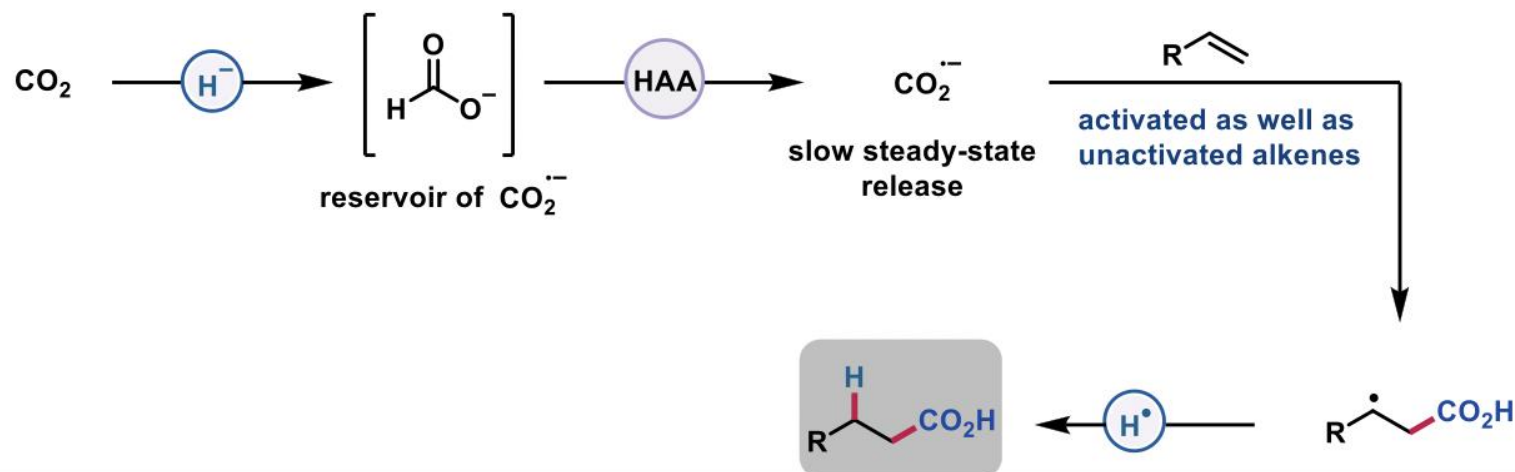

Taming $\text{CO}_2^{\bullet-}$

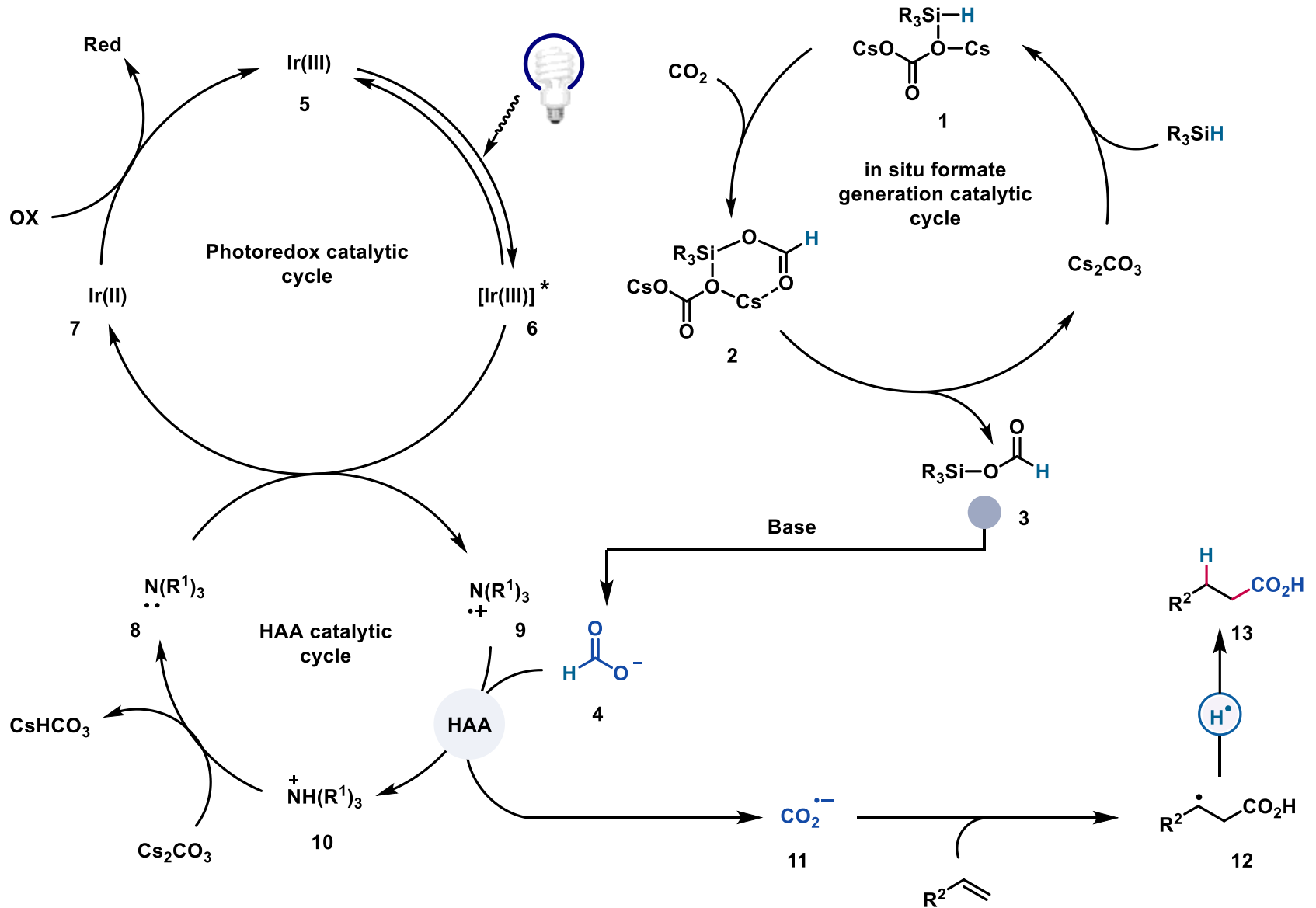

CO₂^{•-} generation

CO₂

Ir-PC (1 mol%), TTMSS (2 equiv.), DABCO (1 equiv.)

Cs₂CO₃ (3 equiv.), DMSO, blue LEDs

CO₂^{•-}

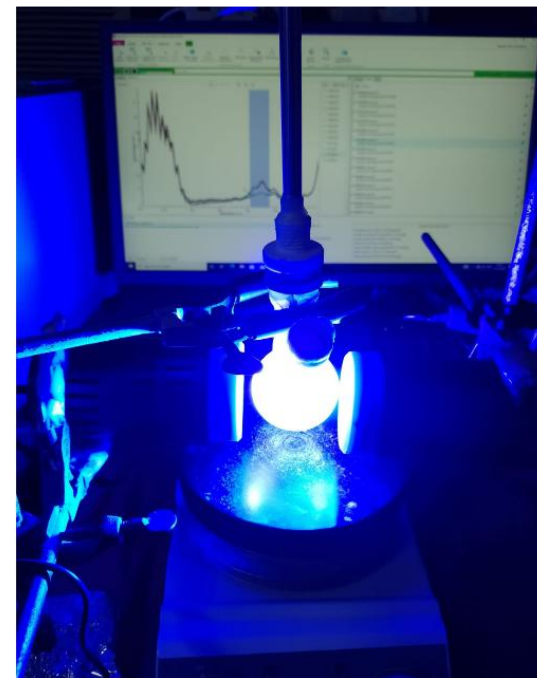
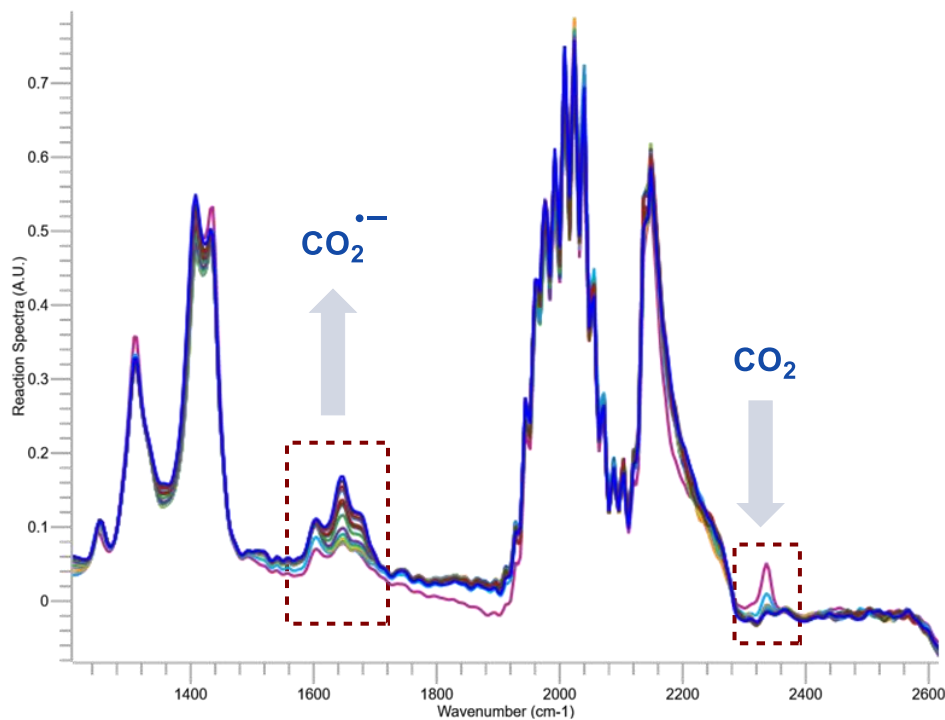

ReactIR FTIR setup

● Probing CO₂^{•-} generation from formate

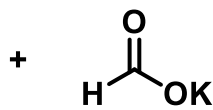
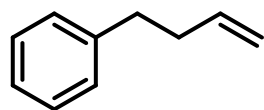

standard reaction conditions

CO₂ radical anion generates from formate

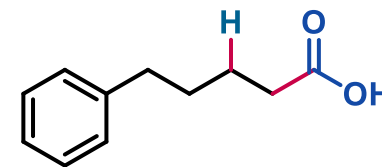

20%

32

Radiolabeling during olefin hydrocarboxylation

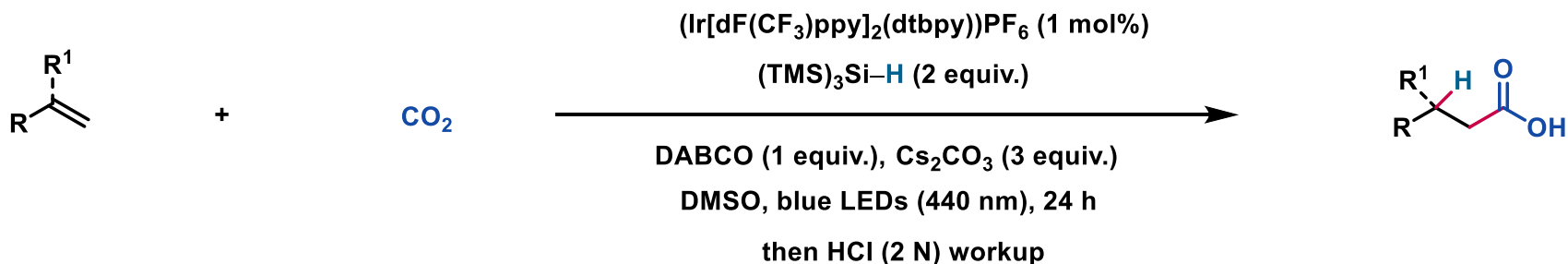

Long chain aliphatic alkene scope

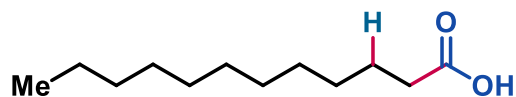

Lauric acid

17, 75%

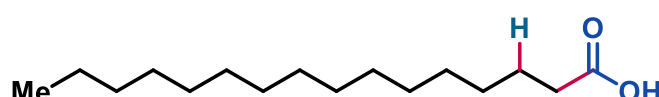

Palmitic acid

18, 71%

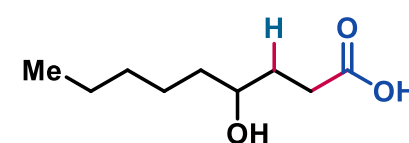

20, 67%

Carbon-13/14 radiolabelling

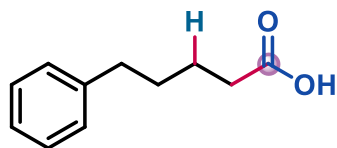

[¹³C]24, (45%), 32%

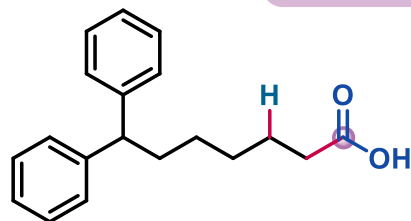

[¹³C]25, (47%), 28%

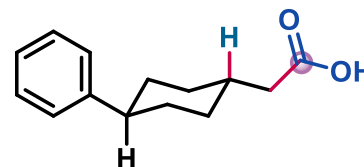

[¹³C]26, (54%), 29%

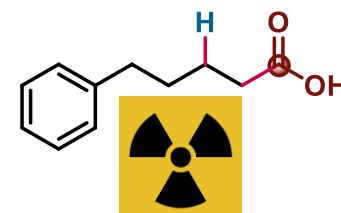

[¹⁴C]27, (39%), 38%
A_m = 0.877 GBq.mmol⁻¹

Thank You @ICOPP@Prof. Aftab Alam

Funding Agencies – BARC, DST, ANRF, CSIR, DRDO, ISRO,
ACTREC, Industry Partners

Collaborators, students



Unlocking new chemical space via selective catalysis



Debabrata Maiti

IIT Bombay, Mumbai, India

www.dmaiti.com

dmaiti@iitb.ac.in

+91-9820907155