



Edge AI for the Internet of Things: Insights from Real-World Projects

Dejan Vukobratovic
Professor
Faculty of Technical Sciences
University of Novi Sad

23. March 2026, ICTP, Trieste



Dejan Vukobratovic

Professor

Communications and Signal Processing Group

Homepage: <https://sites.google.com/view/vukobratovic>

Google Scholar:

<https://scholar.google.com/citations?user=MugUYHgAAAAJ>



The Institute of Artificial Intelligence R&D of Serbia

Affiliated Senior Researcher

Webpage: <https://ivi.ac.rs/en/>



Founding director of ICONIC centre

ICONIC: Centre for intelligent communications, networking and information processing

<https://iconic.ftn.uns.ac.rs/>

University of Novi Sad

<http://www.uns.ac.rs/>

Faculty of Technical Sciences

<http://ftn.uns.ac.rs/>

Department of Power, Electronic and Communications Engineering

<http://deet.ftn.uns.ac.rs/>



Communications and Signal Processing



Electronics



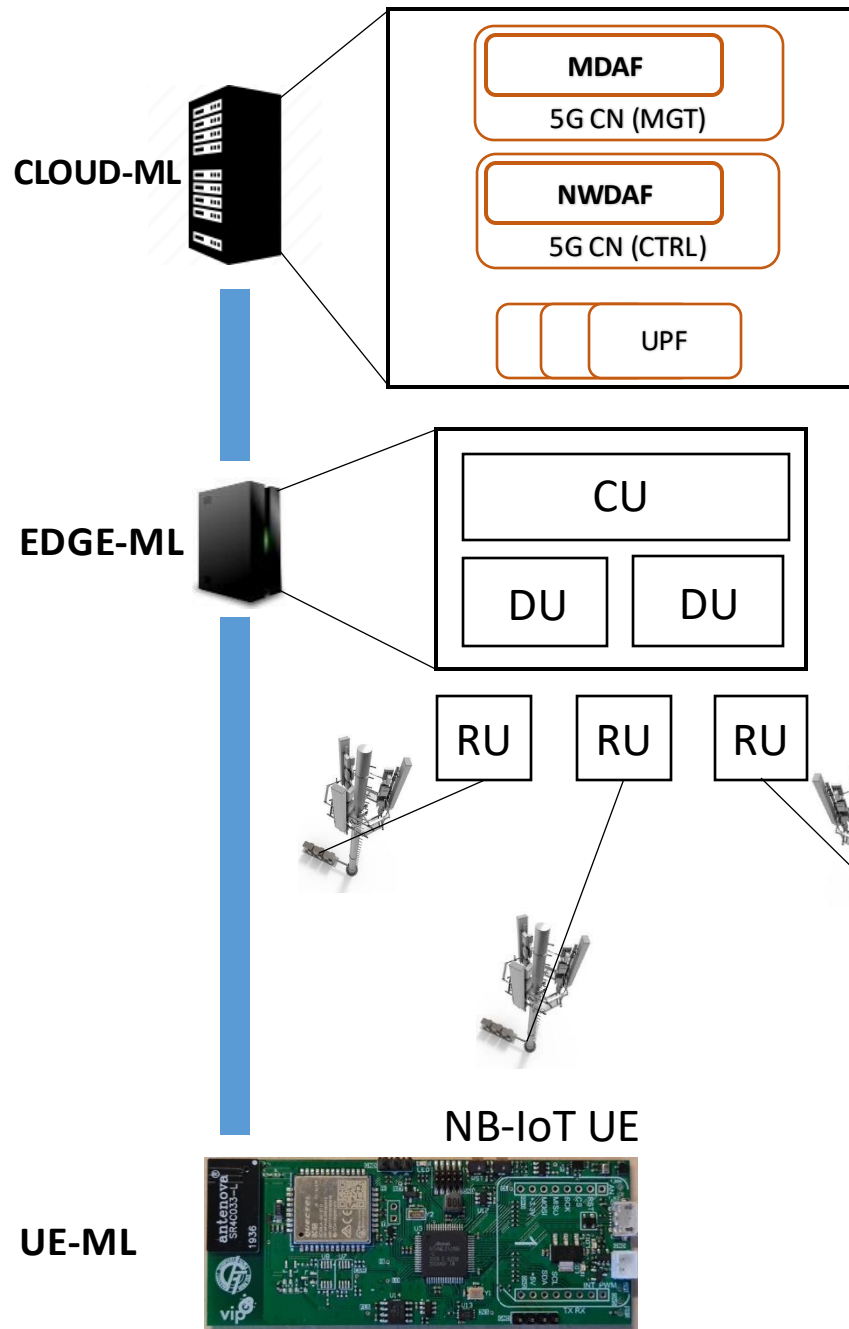

Centralised vs distributed ML/AI deployment in networks

- Delay vs accuracy vs convergence
- Communication costs and complexity

Large-scale distributed inference/optimisation in networks

- Large-scale Graphical models and Belief Propagation
- Message-passing Graph neural networks

Machine learning for the PHY layer

- Classical signal processing vs ML-based PHY layer
- Autoencoder-based PHY design

Fundamental limits of massive connectivity

- Random access design for massive IoT
- Reliability vs Age of information

Machine learning at the Edge

- Low-complexity ML (TinyML)



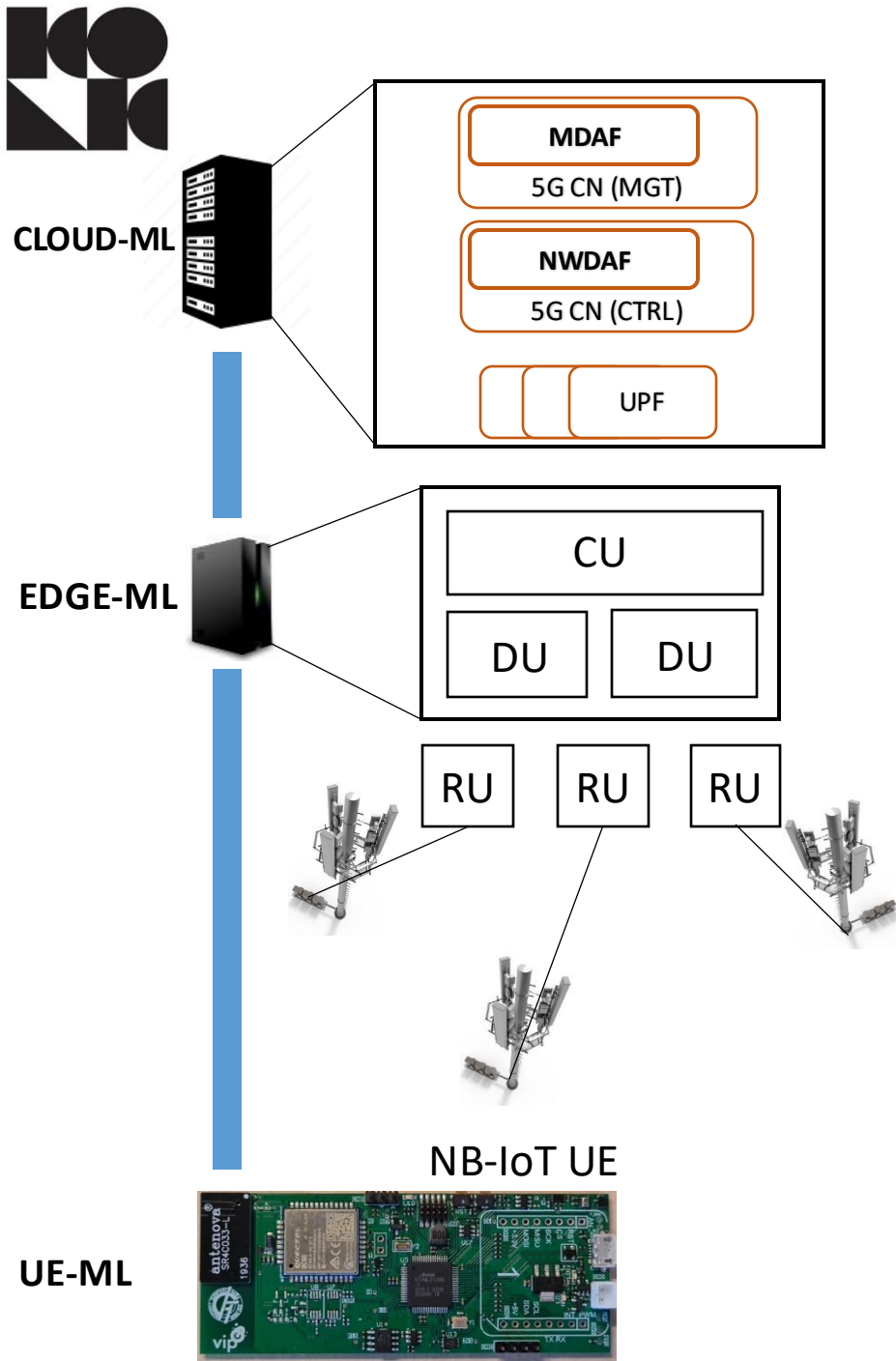

Input features:
 UE SINR/RSSI/RSRQ,
 packet size,
 device GPS coordinates

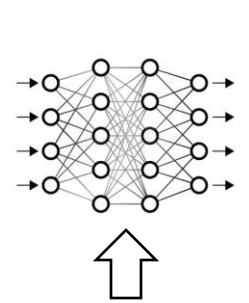

Output:
 consumed energy

A¹

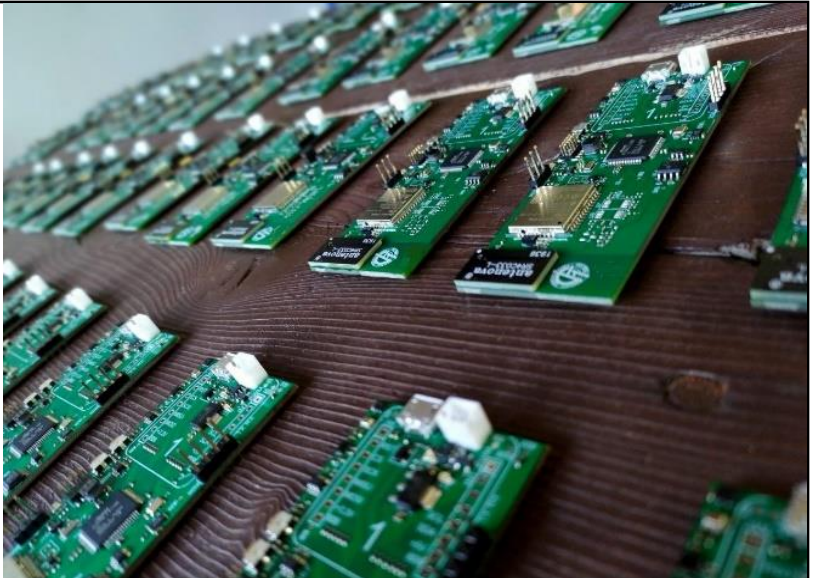
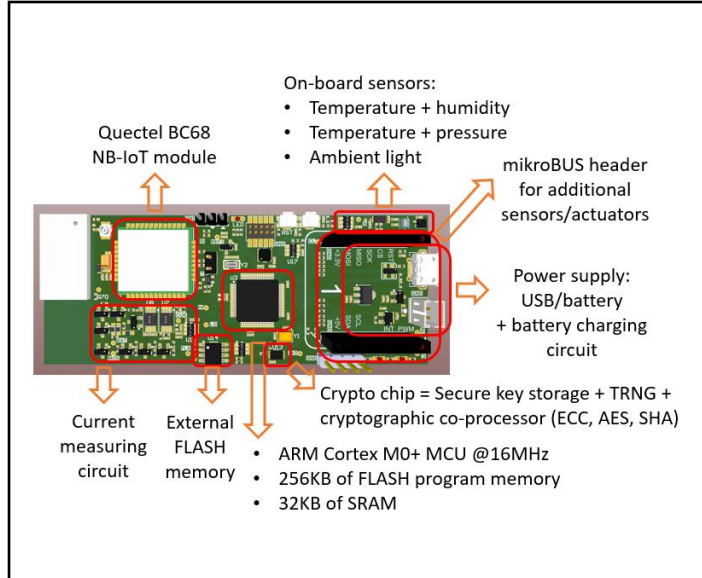
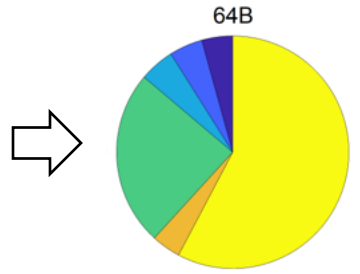
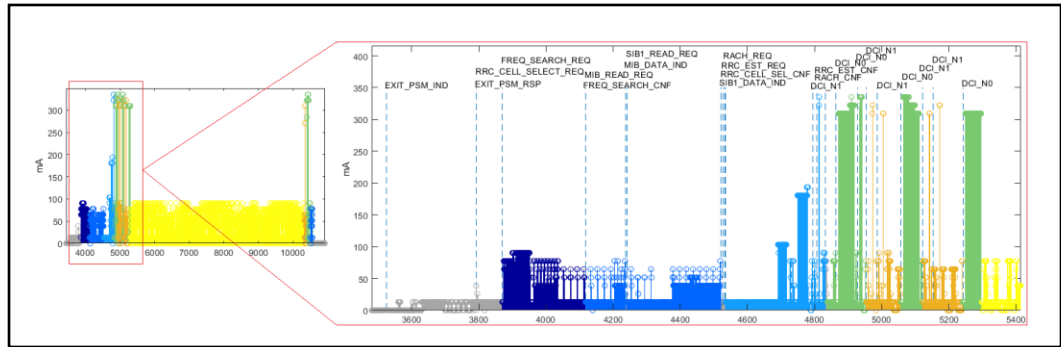

V. Nikic, D. Bortnik, S. Sobot, D. Vukobratovic, I. Mezei, M. Lukic: "Evaluation of Machine Learning Algorithms for NB-IoT Module Energy Consumption Estimation based on Radio Channel Quality," IEEE Access, 2025.

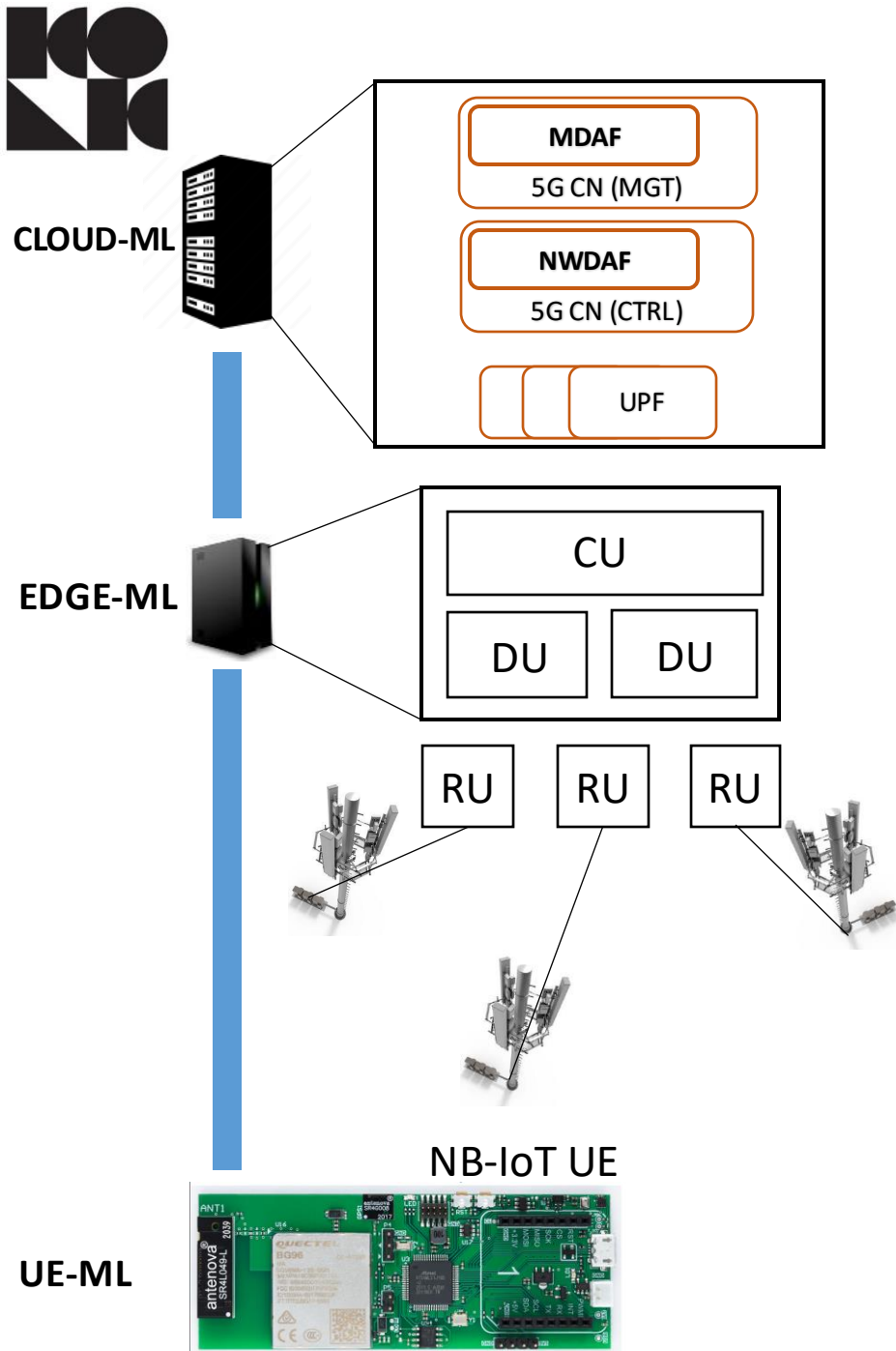

Input features:
Aggregated data from accelerometer

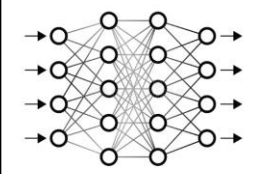

Output:
Anomalous container handling

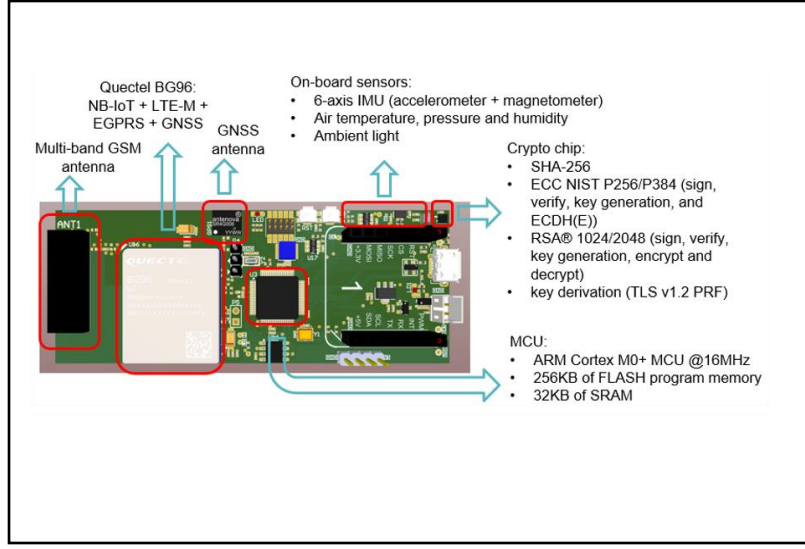
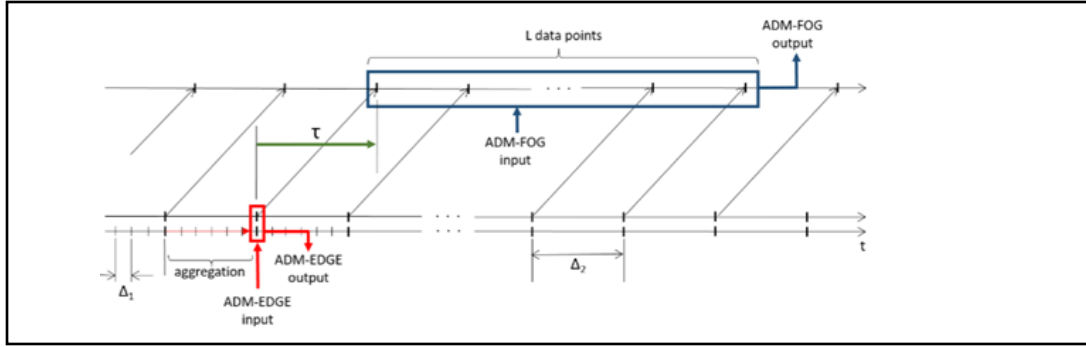

M. Savic, M. Lukic, D. Danilovic, Z. Bodroski, D. Bajovic, I. Mezei, D. Vukobratovic, S. Skrbic, D. Jakovetic: "Deep Learning Anomaly Detection for Cellular IoT with Applications in Smart Logistics," Vol. 9, pp 59406-59419, IEEE Access, April 2021.



CLOUD-ML

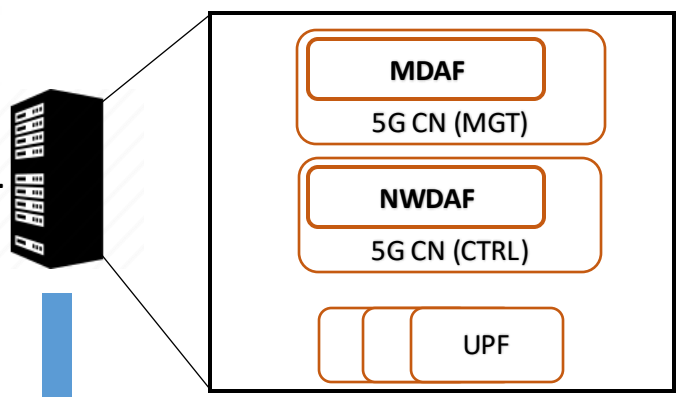

EDGE-ML

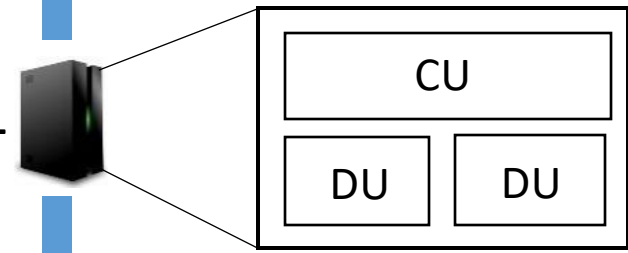

RU RU RU

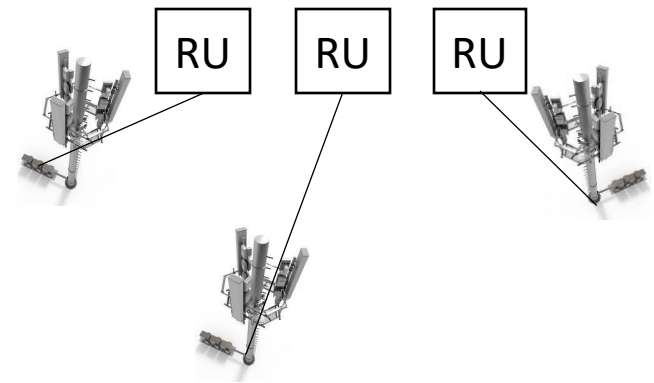

NB-IoT UE



UE-ML

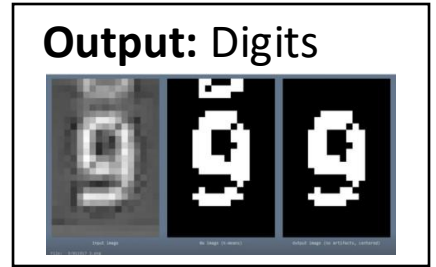
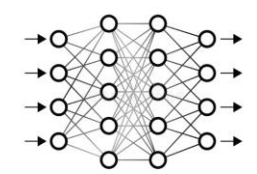
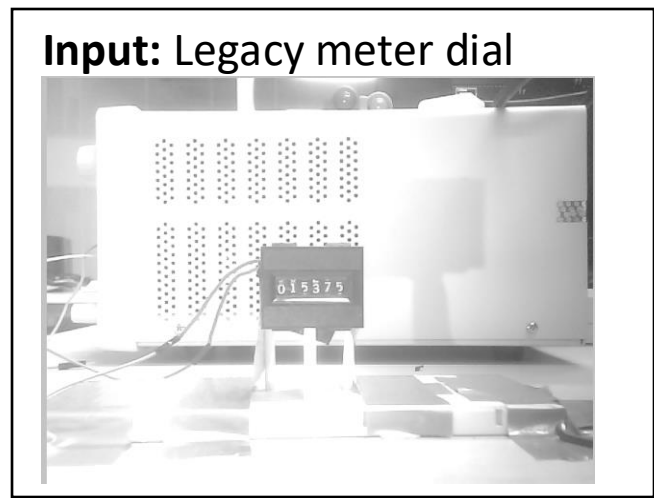
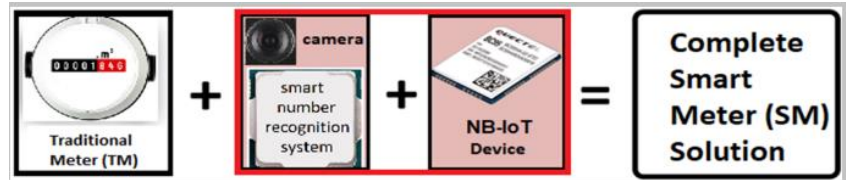

REPUBLIKA SRBIJA
FOND ZA
INOVACIONU
DELATNOST

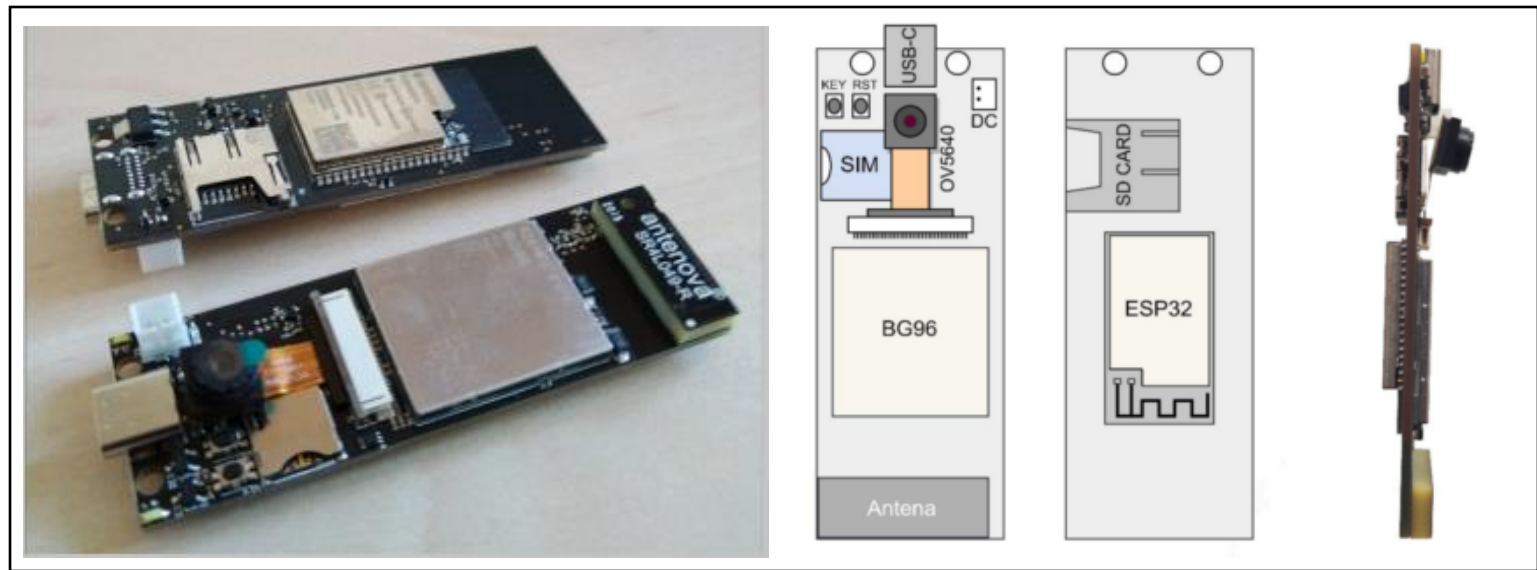
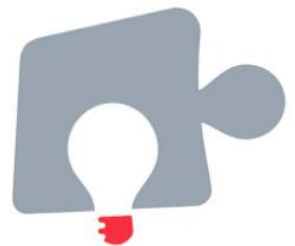

V. Nikic, D. Bortnik, M. Lukic, D. Vukobratovic, I. Mezei: "Lightweight Digit Recognition in Smart Metering Systems Using Narrowband Internet of Things and Federated Learning," **Future Internet**, 16(11), 402, 2024.



CLOUD-ML

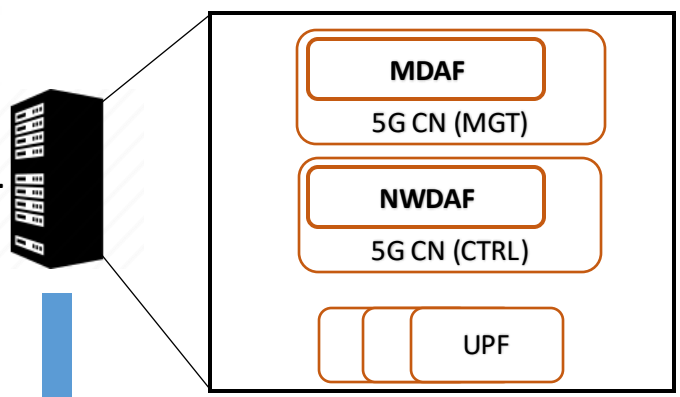

EDGE-ML

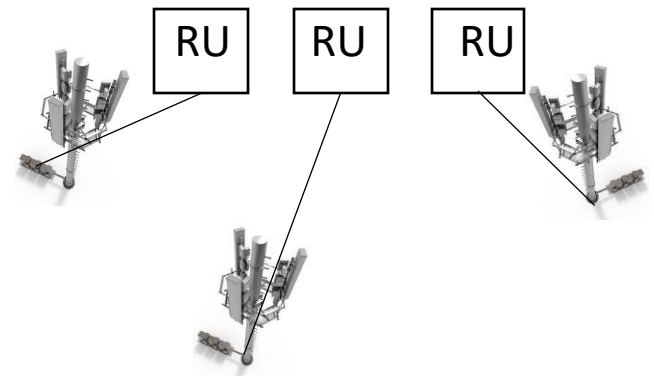
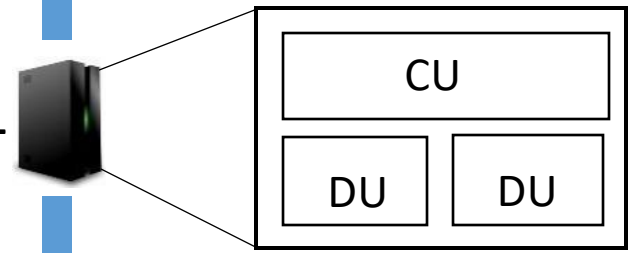

NB-IoT UE

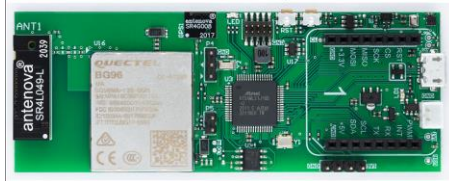

UE-ML

Distributed Collaborative Learning: Split vs Federated Learning for Massive IoT

TinyML implementations on real-world devices

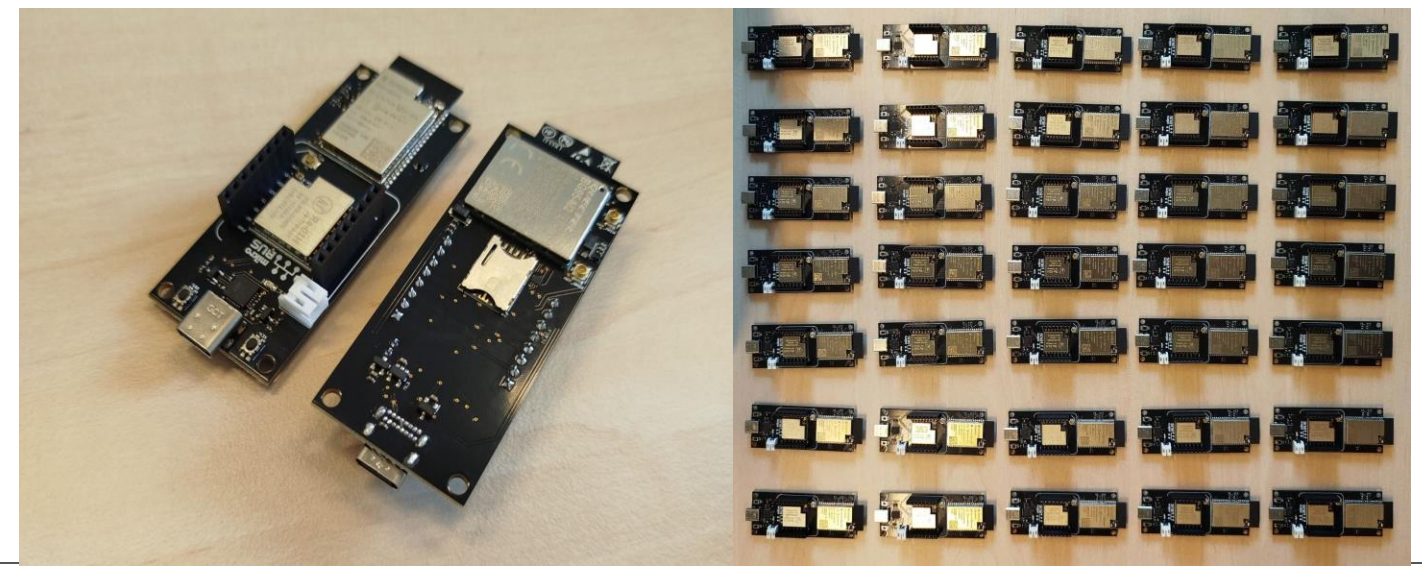
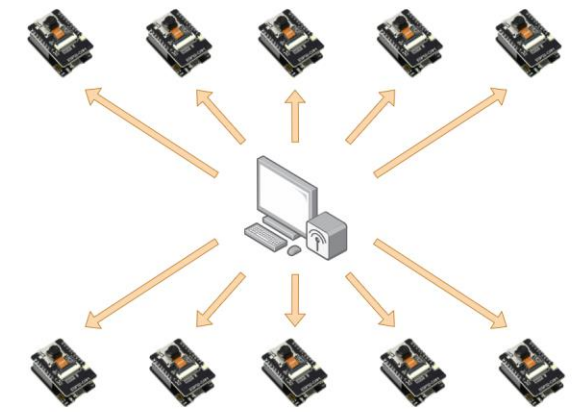
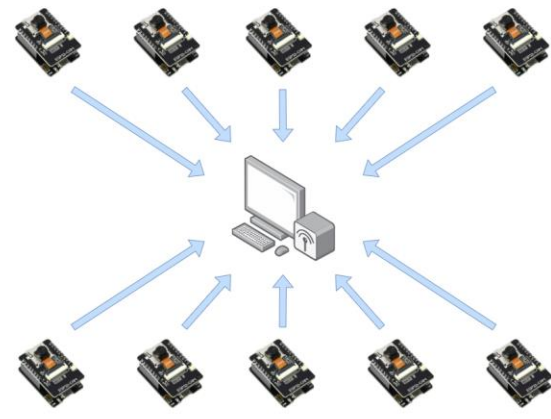

V. Nikic, D. Bortnik, M. Lukic, D. Vukobratovic, I. Mezei: "Lightweight Digit Recognition in Smart Metering Systems Using Narrowband Internet of Things and Federated Learning," **Future Internet**, 16(11), 402, 2024.

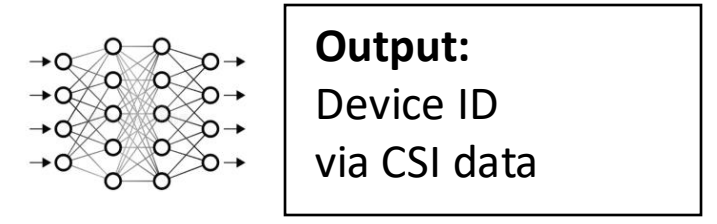
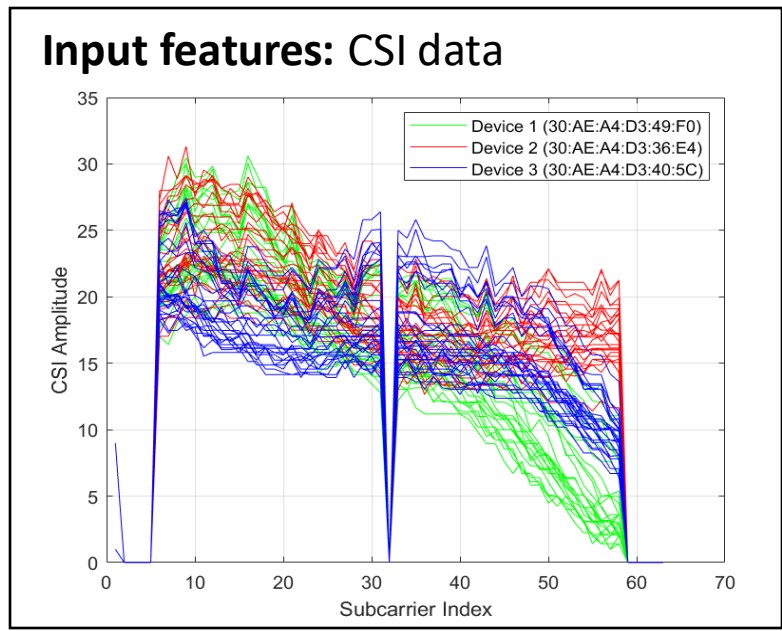
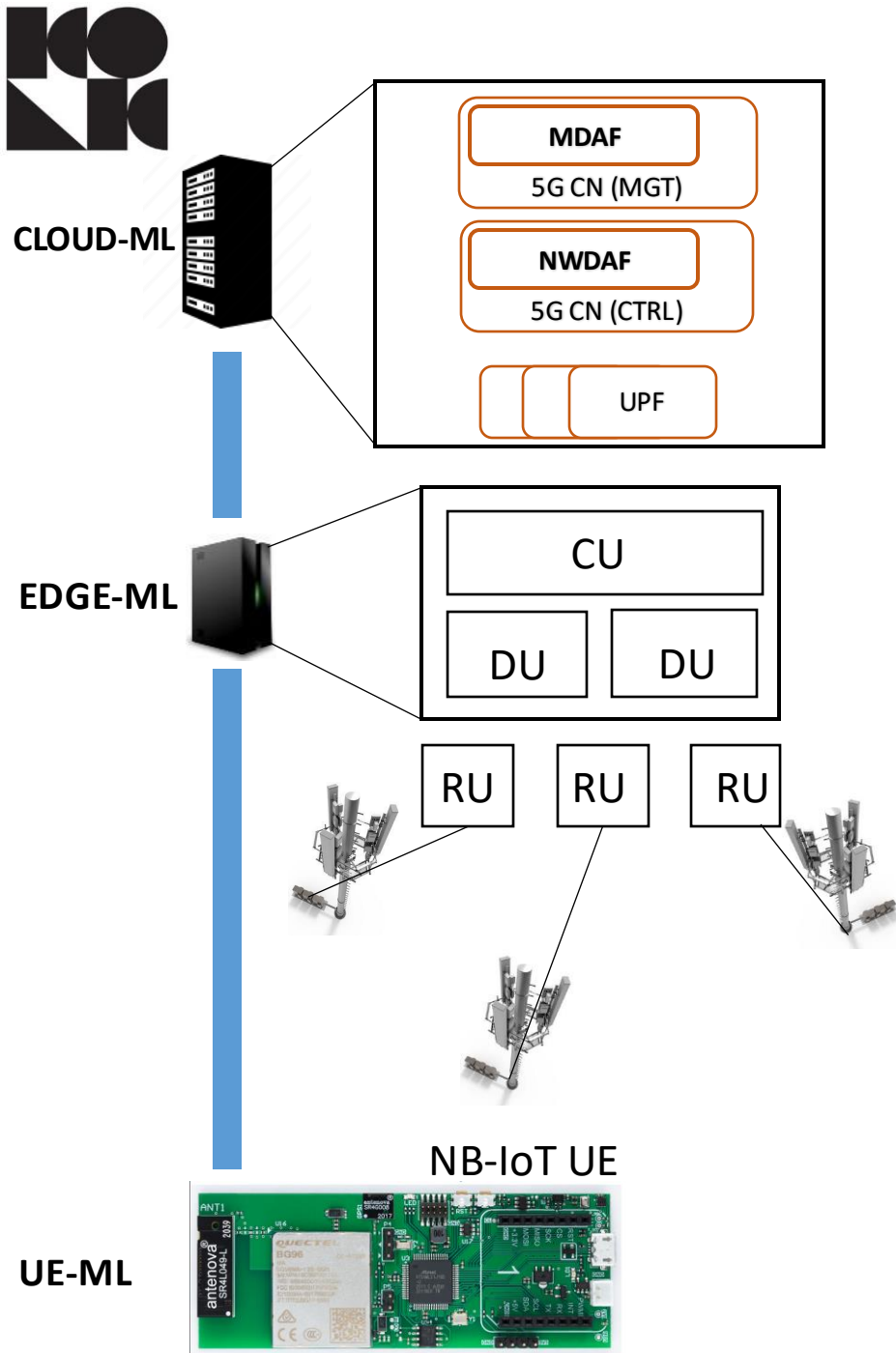

Output:
Device ID
via CSI data



D. Vukobratovic, M. Lukic, I. Mezei, D. Bajovic, D. Danilovic, M. Savic, Z. Bodroski, S. Skrbic, D. Jakovetic: "Edge Machine Learning in 3GPP NB-IoT: Architecture, Applications and Demonstration," EUSIPCO 2022, Belgrade, Serbia, August 2022.



Hybrid Indoor OWC/Outdoor LoRa IoT System

Design of hybrid indoor IoT/outdoor LP WAN (LoRa) connectivity:

- USRP-based OWC prototype (Figure) + LoRa
- IR-based OWC prototype (Figure)
- OpenVLC-based prototype

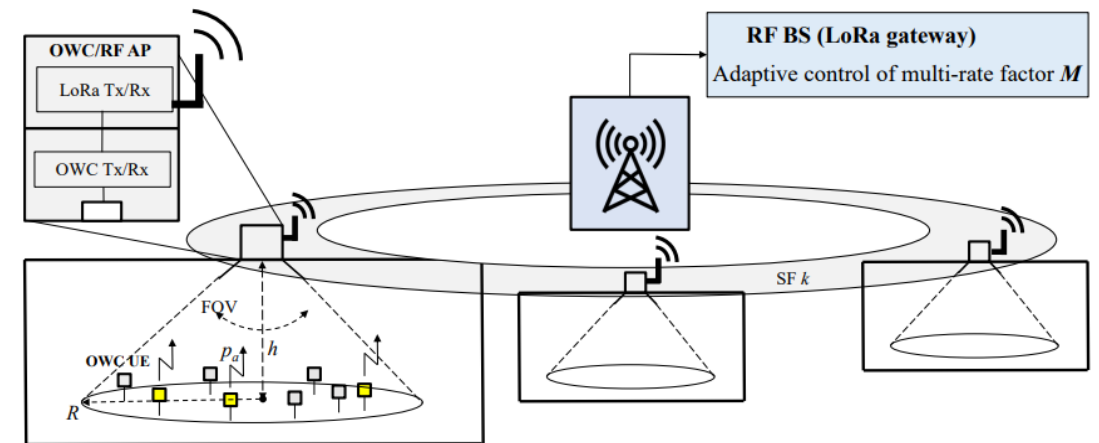
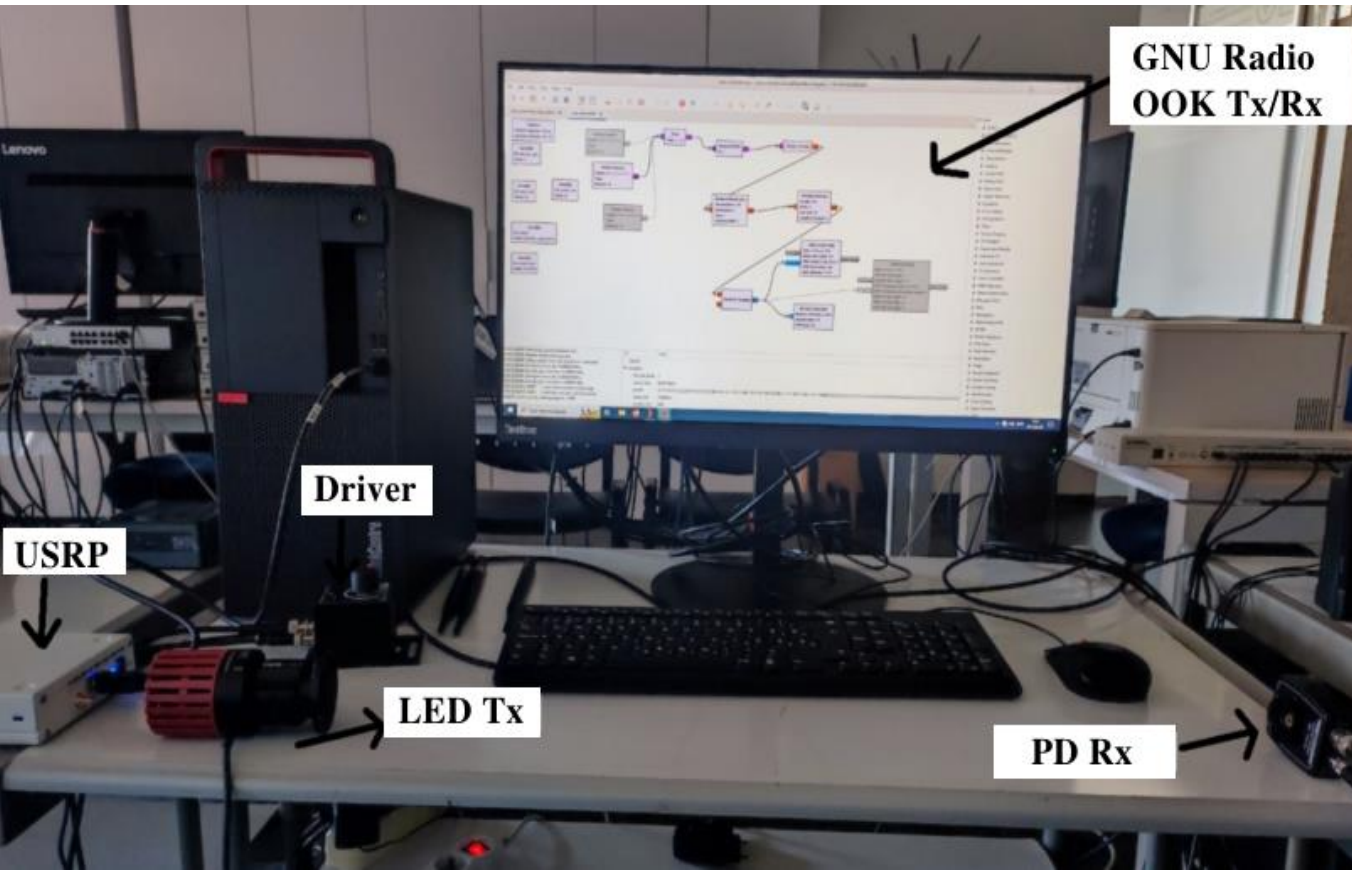
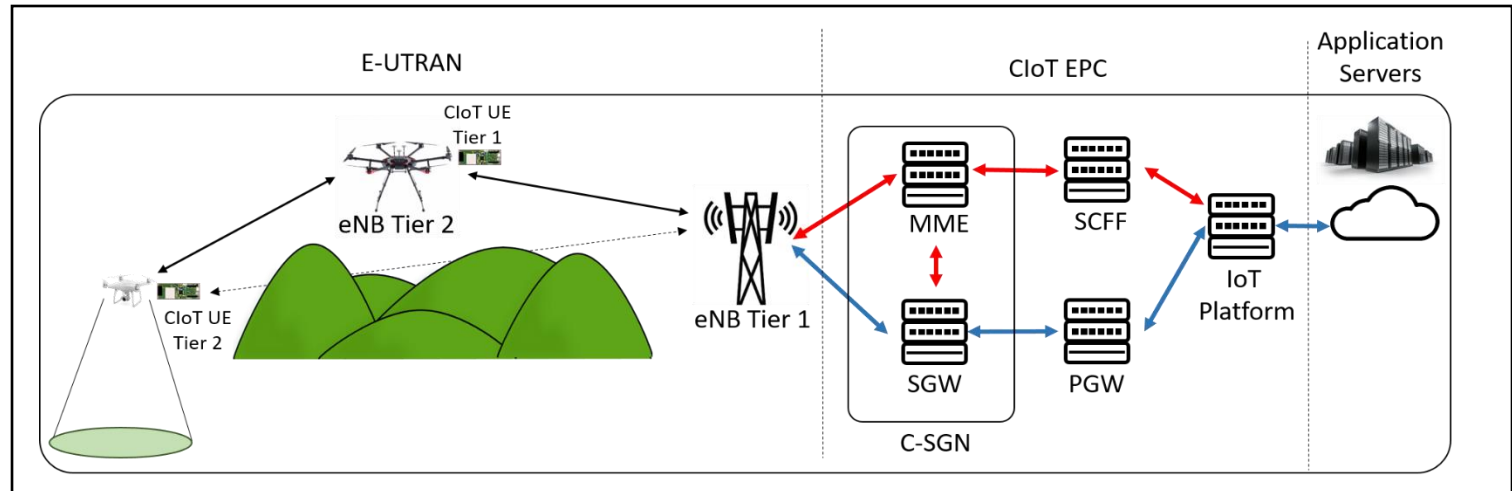
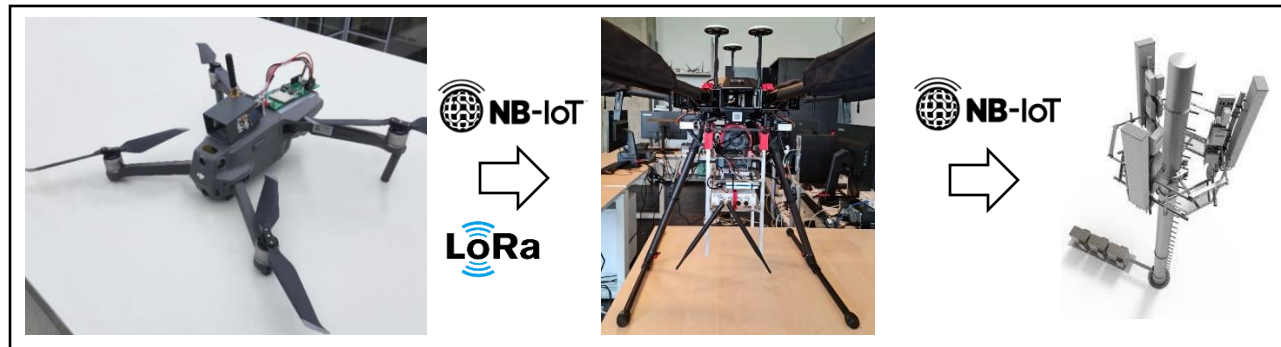
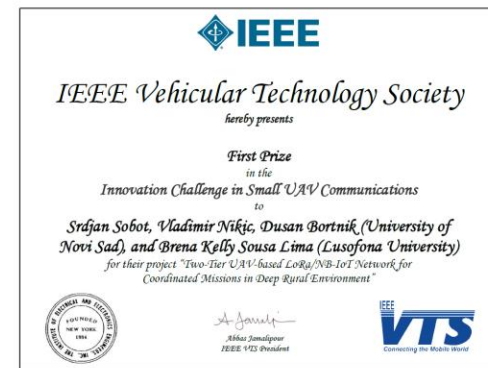
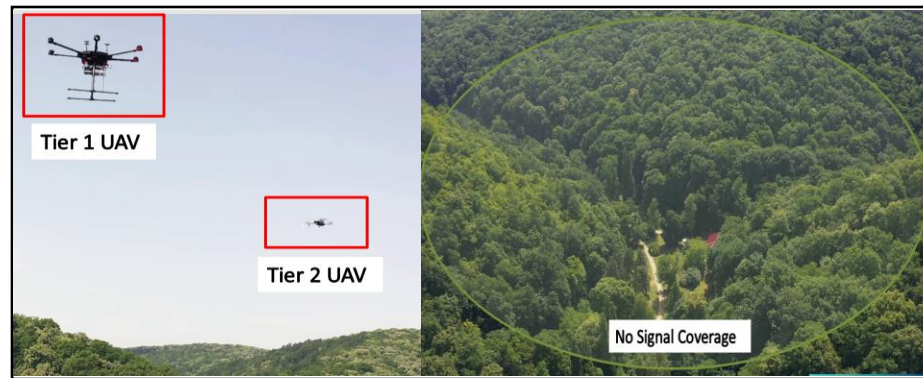
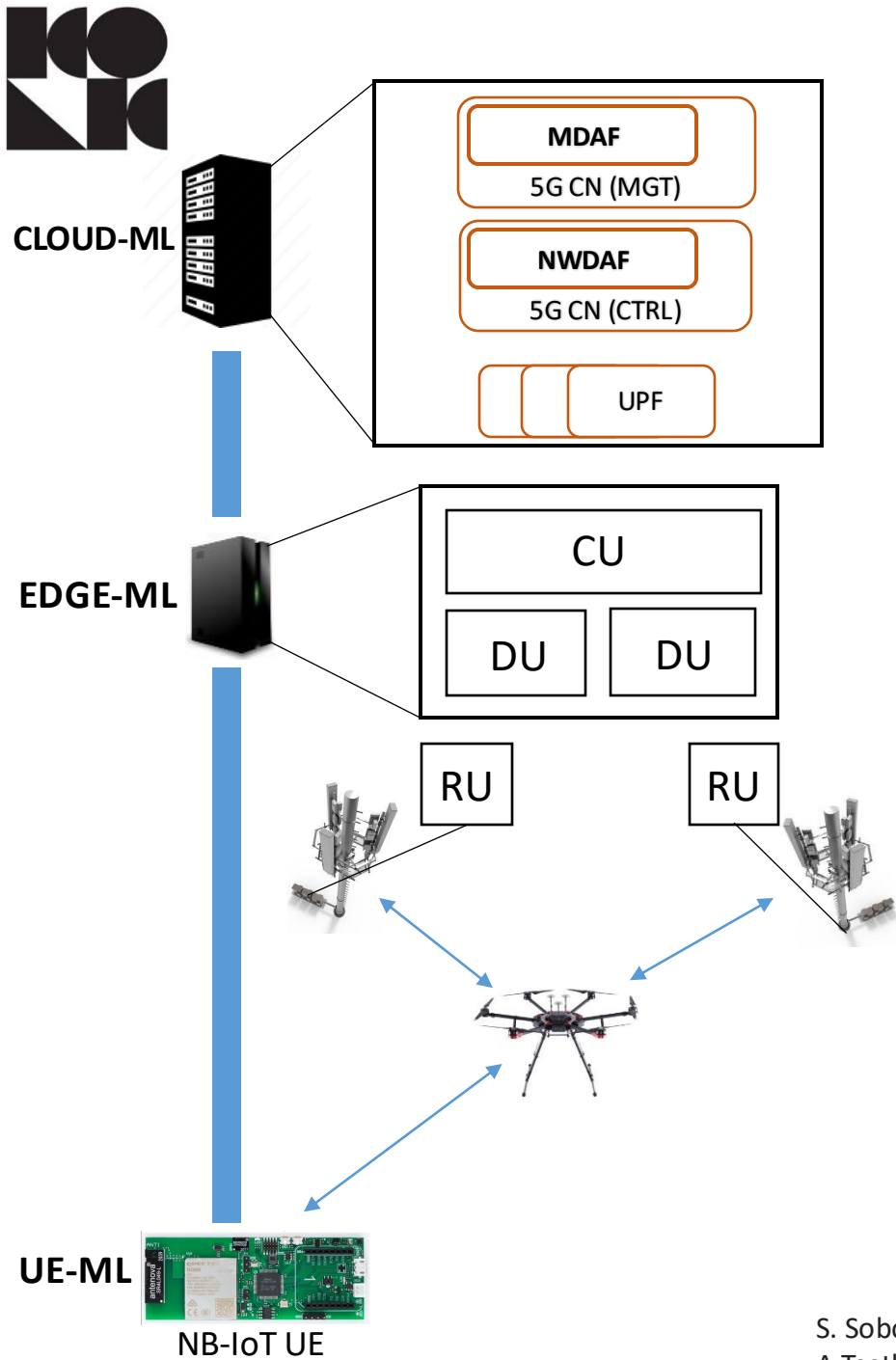

Fig. 1. Two-Tier OWC/RF-Based IoT Network.

T. Devaja, M. Petkovic, F. Escibano, C. Stefanovic, D. Vukobratovic: "Slotted ALOHA with Capture for OWC-Based IoT: Finite Block-Length Performance Analysis," *IEEE Access*, Vol. 11, pp 76804-76815, 2023.

M. Petkovic, D. Vukobratovic, F. Clazzer, A. Munari, "Two-Tier Multi-Rate Slotted ALOHA for OWC/RF-Based IoT Networks," *IEEE Communication Letters*, Vol. 27, No. 4, pp. 1190-1194, April 2023.



S. Sobot, M. Lukic, D. Bortnik, V. Nikic, B. Lima, M. Beko, D. Vukobratovic: "Two-Tier UAV-Based Low Power Wide Area Networks: A Testbed and Experimentation Study," Int'l Conf on Cloud and Internet of Things Clot 2023, Lisbon, Portugal, March 2023.



Science Fund
of the Republic of Serbia
REWARDING

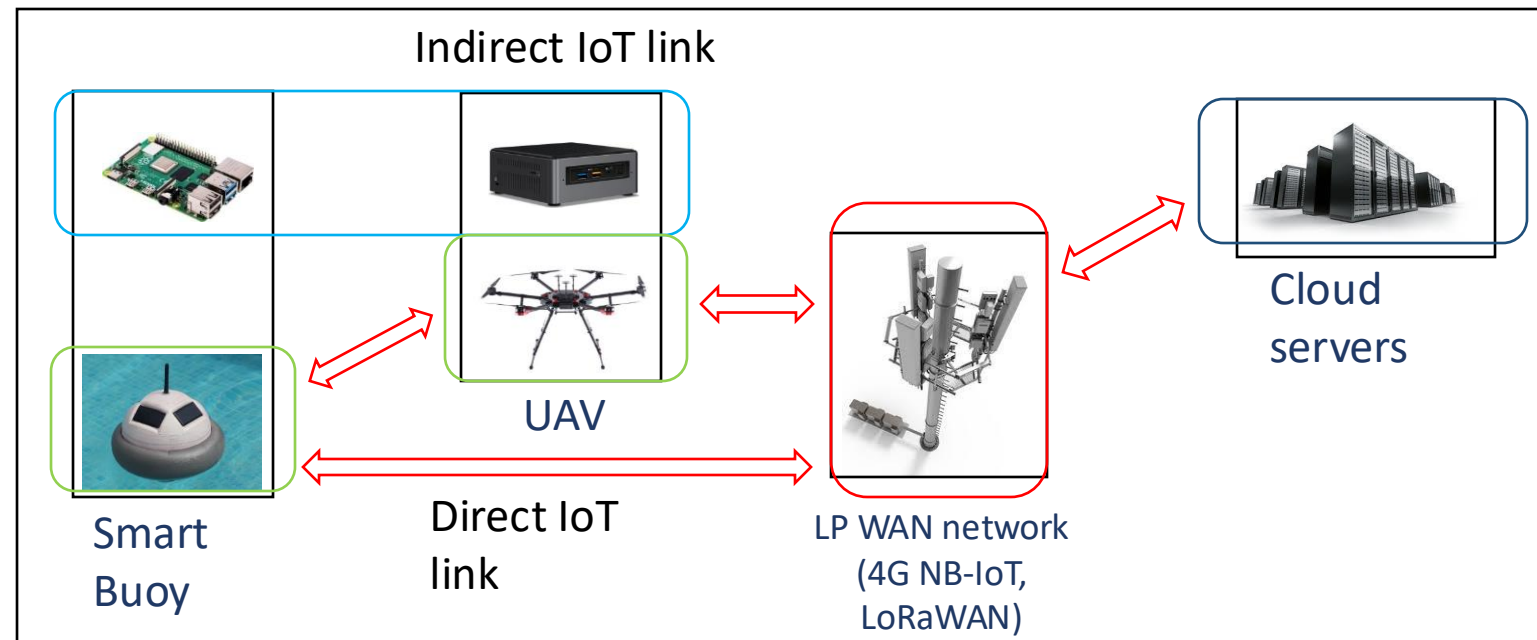
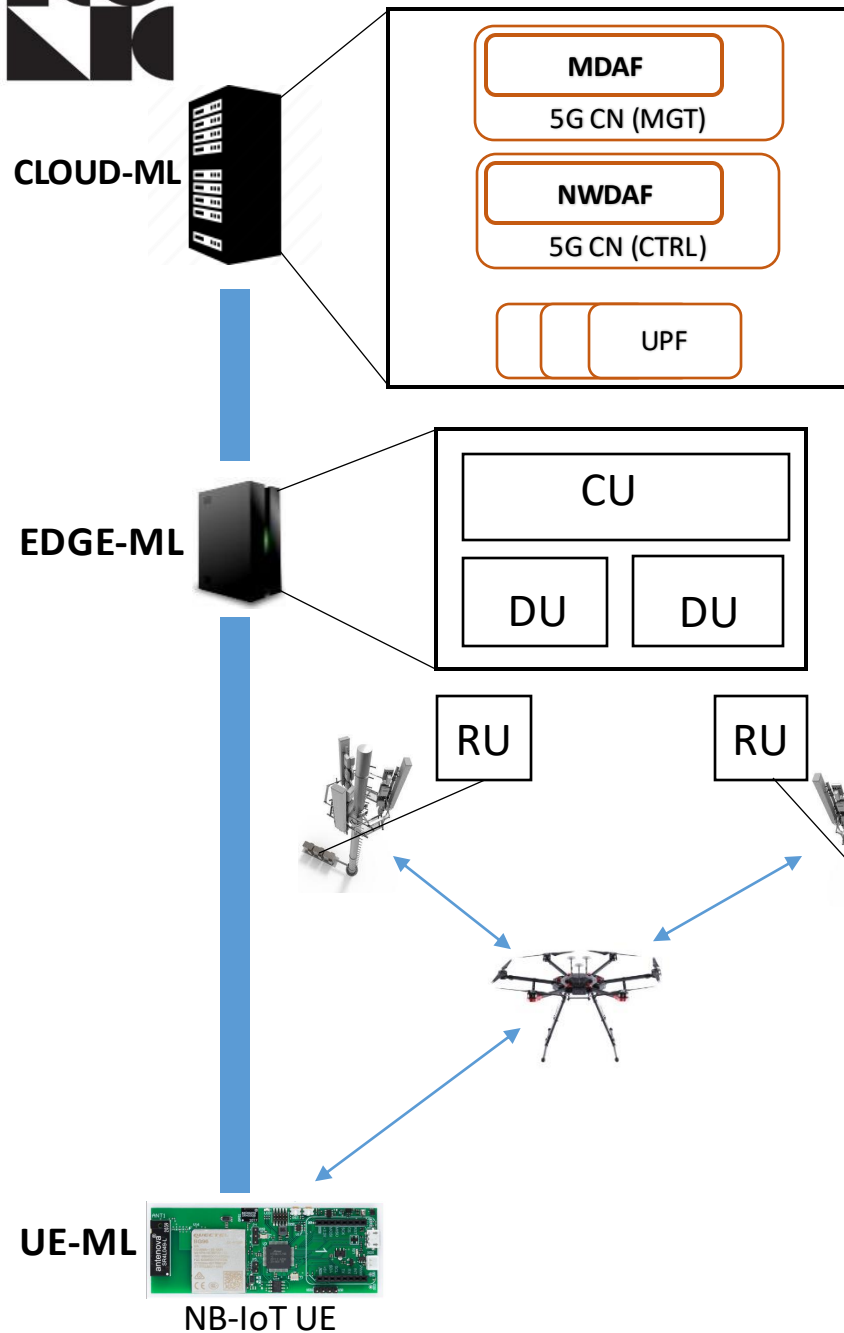

Environmental monitoring LP WAN testbed

Urban Environmental Monitoring Testbed

Plan: City-wide environmental monitoring testbed

Telekom Serbia C-IoT infrastructure (NB-IoT/LoRa)

- Free-of-charge access to Telekom Serbia C-IoT infrastructure

20+ rainfall Lambrecht measurement sensors (+ THP meteo)

20+ air quality measurement sensors

Water quality measurement buoys + drone water sampling

Backend infrastructure (data storage, MLOps, visualisation)

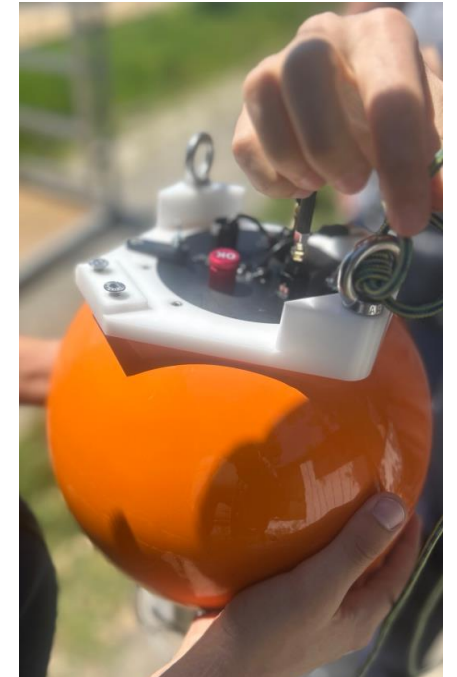
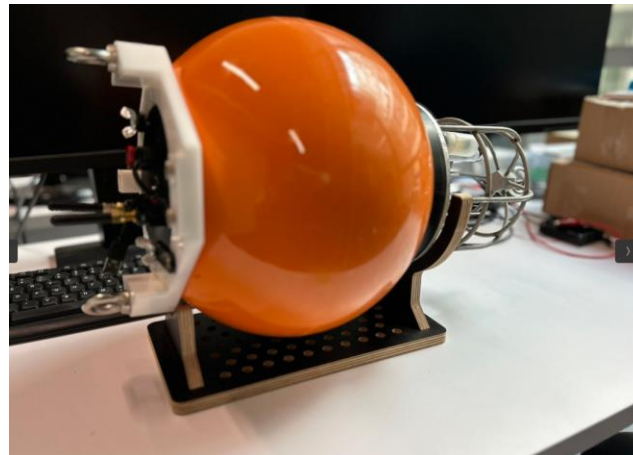

Edge ML for Massive Cellular IoT Networks

- Most of the IoT use cases deal with **time-series data**
- Data sources frequently overwhelm **limited capacity IoT data connection**
- Excessive data transfer also leads to **limited battery lifetime**
- One solution is to **offload ML model to the edge** IoT device
- **Limited edge device compute**: this may work if the model is simple
- Can we **reduce the amount of transmitted data** via data compression?
- Cost of **Compression vs Edge ML model processing**?
- Extract only relevant data for a given context: **Semantic communications**?
- Compression **aims to reconstruct source data**, SemCom does not!
- Can we design **end-to-end model** that is **optimal for a given ML task**?
- **Effective or Goal-Oriented Communications**

Goal-Oriented Communications

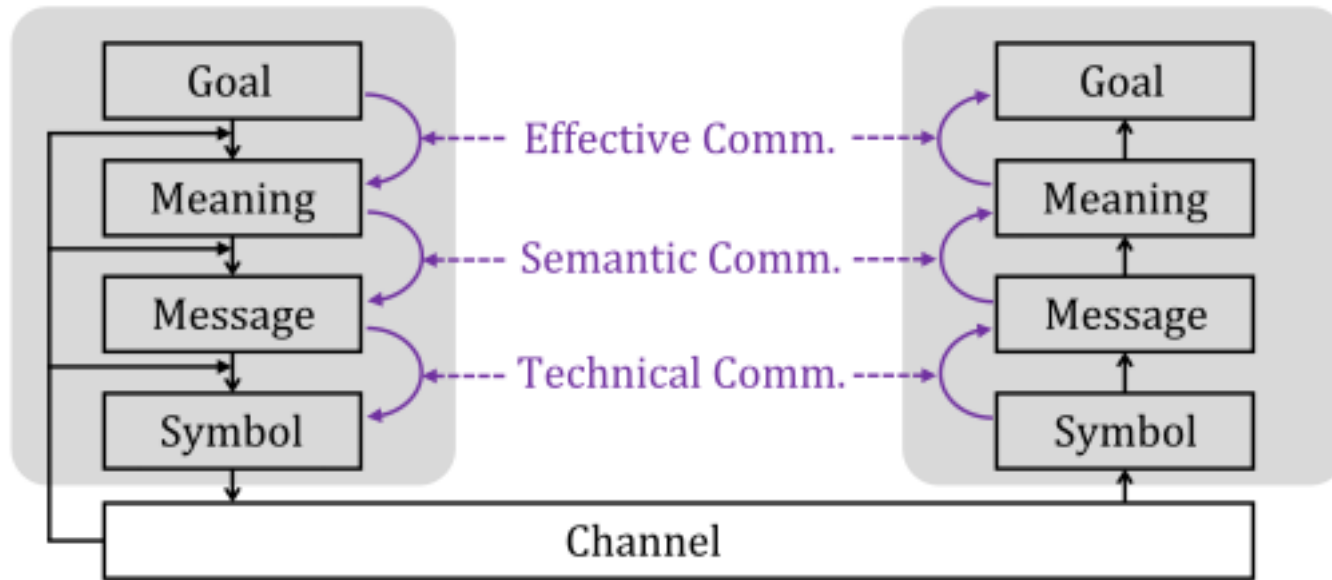

The effectiveness problem: How effectively does the received meaning affect desired conduct?

The semantic problem: How precisely do the transmitted symbols convey the desired meaning?

The technical problem: How accurately can the symbols of communication be transmitted?

Traditional Shannon-theory communications solves only the technical problem of communications.

C. E. Shannon and W. Weaver, *The Mathematical Theory of Communication*. Urbana, IL, USA: Univ. Illinois Press, 1949.

Y. Shao, Q. Cao, D. Gündüz, *A theory of semantic communication*. *IEEE Transactions on Mobile Computing*, 23(12), 2024.



Edge AI for the Internet of Things: Insights from Real-World Projects

Dejan Vukobratovic
Professor
Faculty of Technical Sciences
University of Novi Sad