

Global Nuclear Energy Scenarios in INPRO Studies and Role of SMRs

Joint IAEA-ICTP Workshop on Reactor Physics, Thermal Hydraulics and Plant Design
Engineering of Small Modular Reactors, Trieste, Italy, 13-17 April 2026

Alexander Bychkov - IAEA consultant / international expert,
Ex-DDG-NE IAEA (2011-2015)
in cooperation with J.M.C.Johari and T.Mai Vu – Nuclear Engineers
(IAEA/INPRO)

International Project on Innovative Nuclear Reactors and Fuel Cycles (INPRO)



- INPRO is a **key forward looking IAEA activity** assessing nuclear energy systems integrated with the “One House” of the IAEA
- The INPRO **members are key drivers** of projects and tasks in INPRO
- INPRO promotes **the innovation** in the areas of:
 - Nuclear reactors
 - Nuclear fuel cycles: front-end and back-end
 - Institutional approaches for nuclear power
- INPRO assists the Member States in **National strategic and long-term planning**
- INPRO develops and provides tools and services
- INPRO promotes the Partnerships for Nuclear Futures

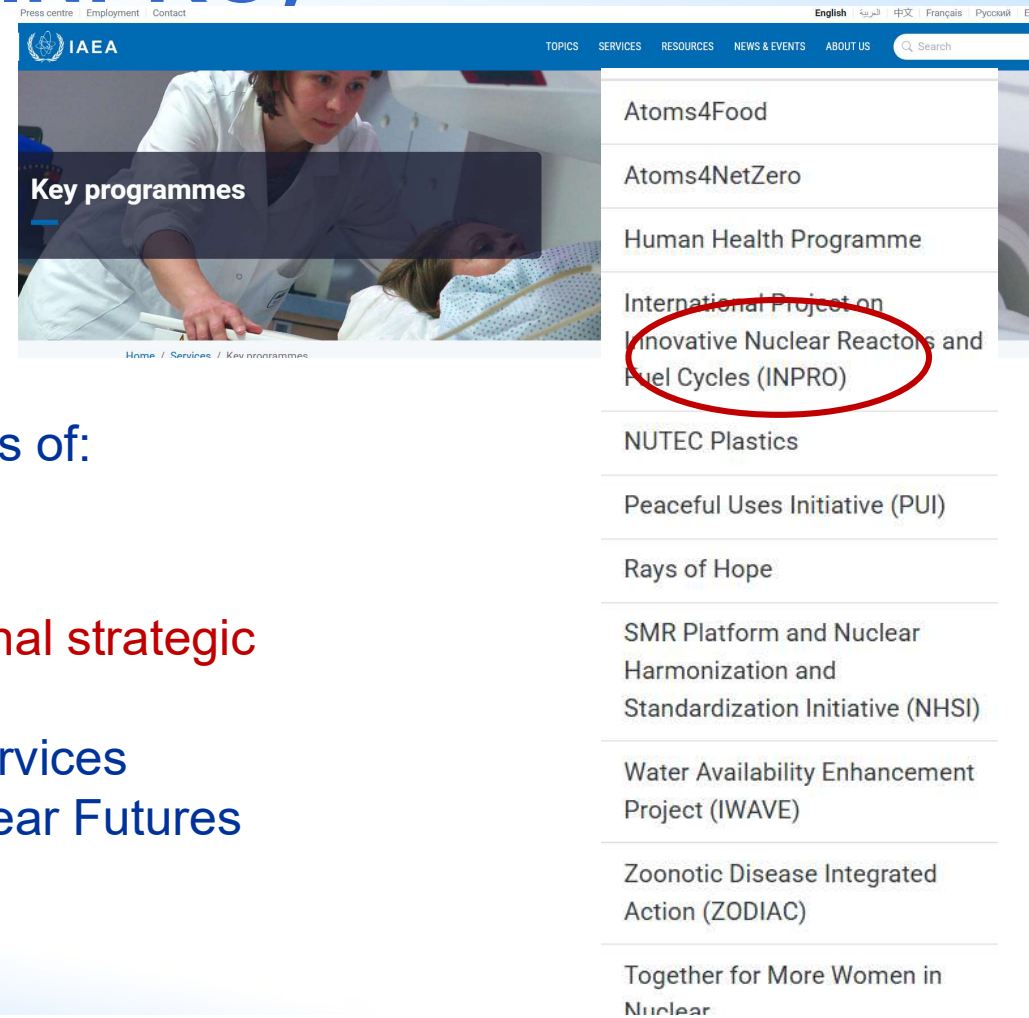

INPRO

International Project on
Innovative Nuclear Reactors
and Fuel Cycles

Sustainable nuclear energy planning

Nuclear energy can contribute in a sustainable manner for a century and beyond

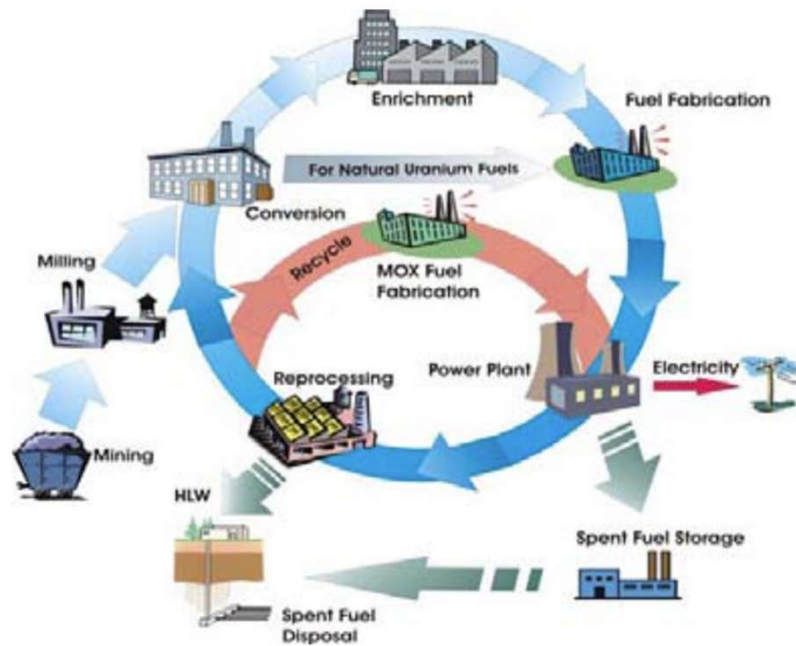

INPRO Methodology

- Comprehensive
- Focus on **facilities** (e.g. SMR)
- Time: sustainability for 100 years
- Supports future generations in meeting their needs

2025

2050

2075

2100

2125

INPRO Mission and Vision

IAEA Statute, ARTICLE II: Objectives

The Agency shall seek to accelerate and enlarge the contribution of atomic energy to peace, health and prosperity throughout the world

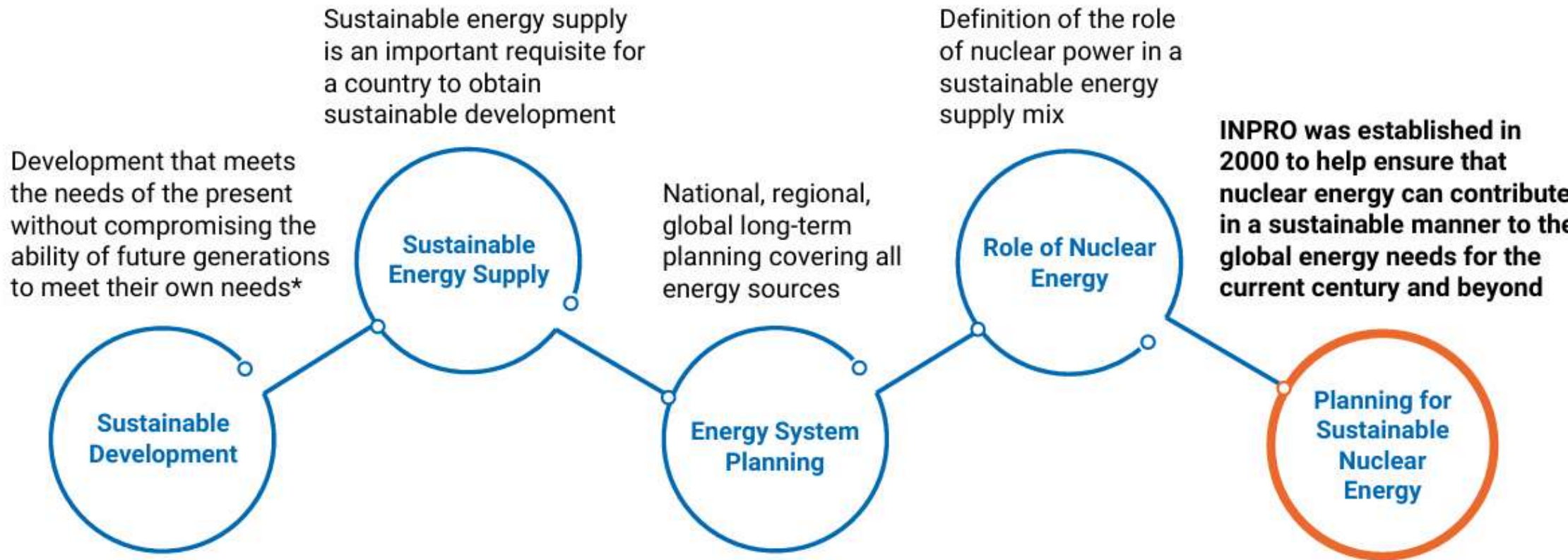

* Our Common Future: Report of the UN World Commission on Environment and Development (Brundtland Commission), 1987

INPRO Methodology Developed to Address Nuclear Energy Sustainability

UN concept for sustainable development of energy

INPRO methodology for sustainability assessment

1. Economic

2. Environment

3. Society

4. Political/Institutional

Economics

Environment

Waste

Safety

Infrastructure

**Sustainable
Nuclear
Energy**

Proliferation

NESA: Assessing for long-term sustainability

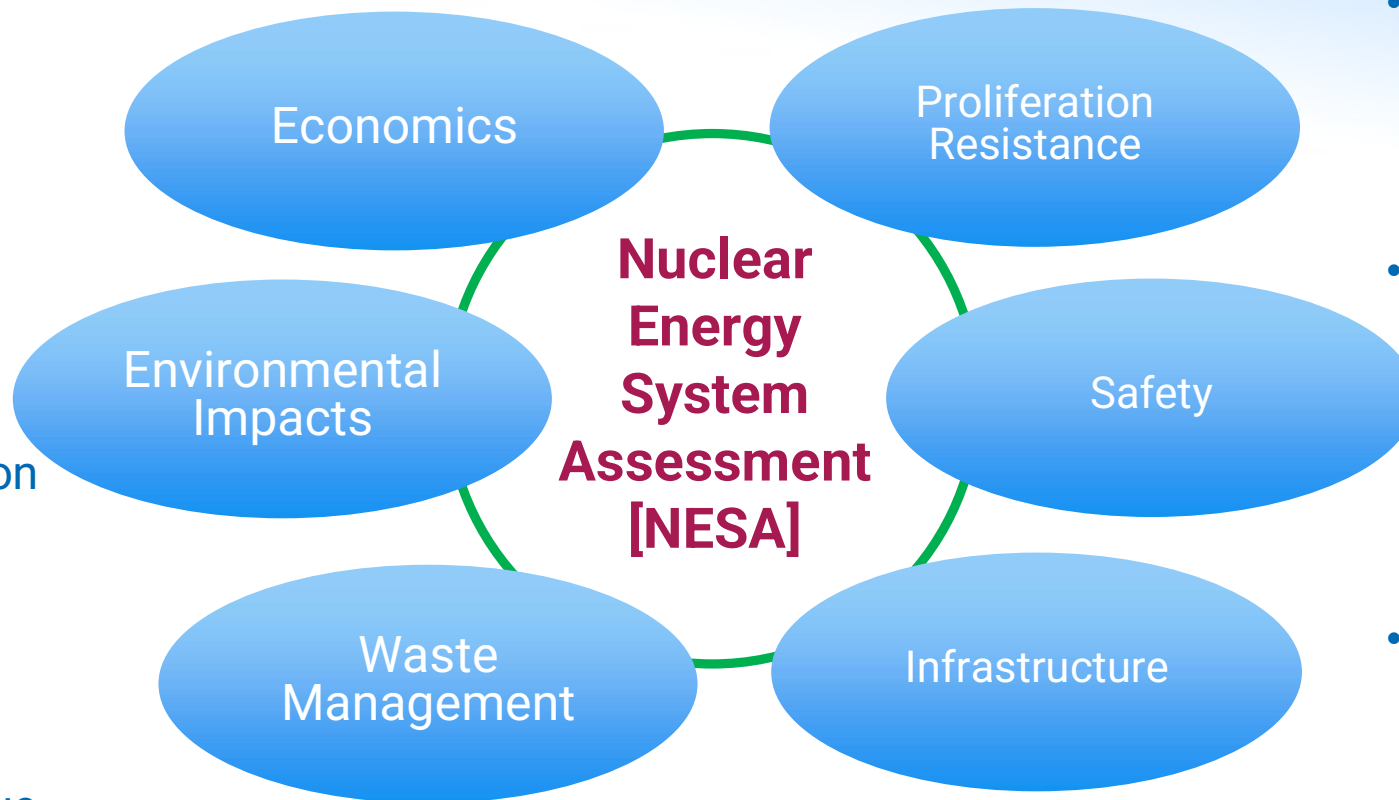

- Economically attractive and competitive
- No adverse impacts on environment, consider depletion of resources
- Protect current and future generations; do not pass on undue burdens

- Unattractive means to nuclear weapons or explosive devices
- Safer than previous generations, reduced off-site releases and impact
- National and international measures to ensure NES is sustainable

Holistic and systematic approach
Protects future generations

Hierarchical Framework

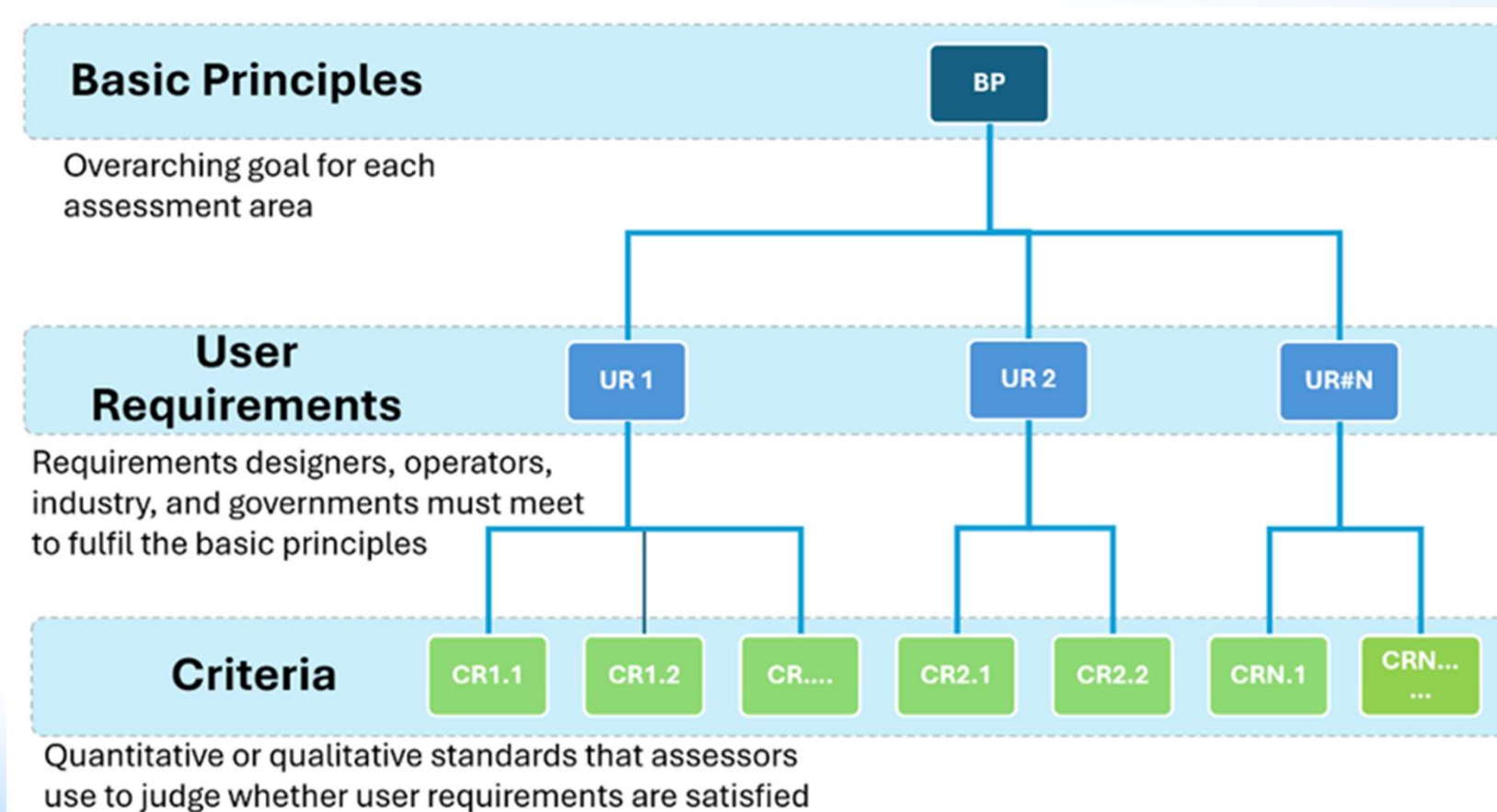

Sustainability Assessments Benefits

Newcomer Country

- Assisting with planning and decision making
- Increasing awareness of long-term issues
- Limiting scope
- Uses a graded approach

State / Government Institutions

- Maintaining or expanding NES
- Comparing options
- Identifying gaps
- Identifying synergies amongst NES combinations

National Industry

- Comparing options
- Identifying improvements
- Identifying areas for research and development

Designer / Technology Developer

- Guiding development
- Comparing options
- Identifying options with advantages
- Identify areas for R&D

Types of NESAs

Limited scope (newcomers / others)

- By assessment area
- Current INPRO project looking at SMR: Economics and Safety

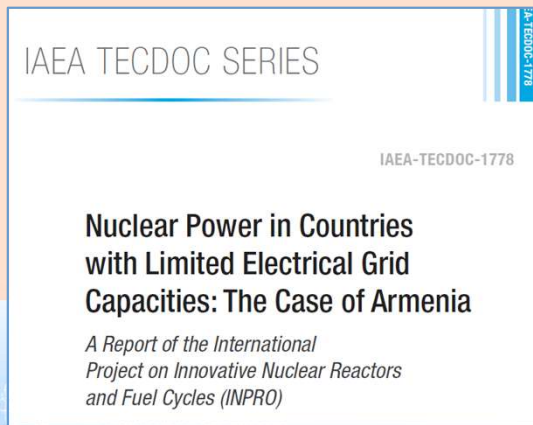

Innovative Nuclear Reactors and Fuel Cycles

Limited scope (developer)

- Identification of critical issues, i.e., gaps to be closed
- Balanced design, i.e., avoidance of undesirable consequences in one area caused by development in another area

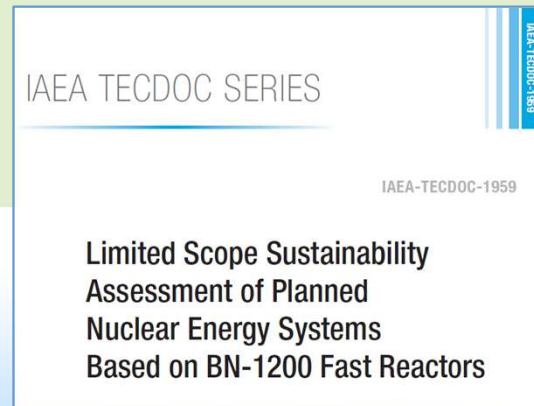

Full scope (users)

- Identification of gaps in early deployment of additional units
- Identification of potential advantages of different NES options
- Newcomers
 - Increase awareness of nuclear issues, i.e., educational tool
- Assistance in planning and decision-making process

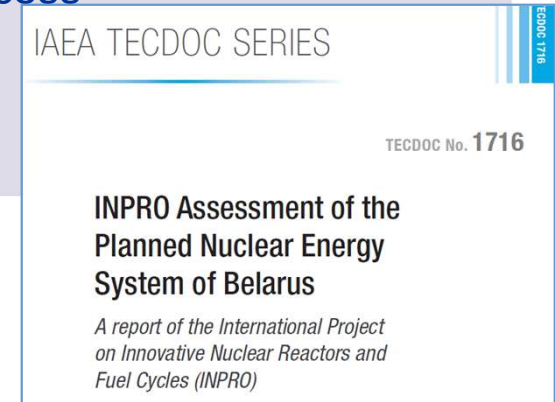

Application of the INPRO Methodology: Achievements in NESAs (SMRs)

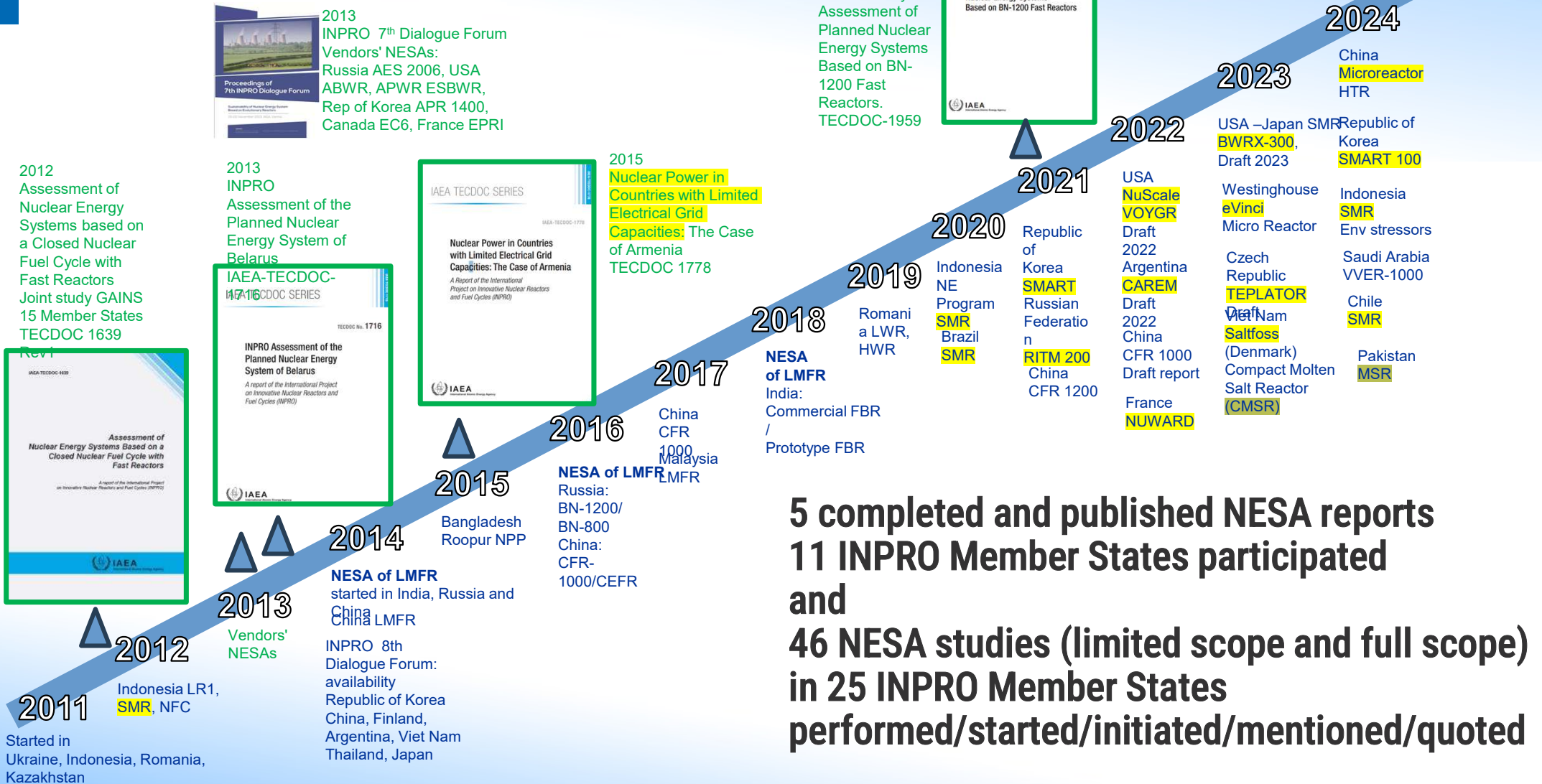

5 completed and published NESAs reports
11 INPRO Member States participated
and
46 NESAs studies (limited scope and full scope)
in 25 INPRO Member States
performed/started/initiated/mentioned/quoted

INPRO Task Structure

1. Global Scenarios:
Collaborative projects, modelling and analysis

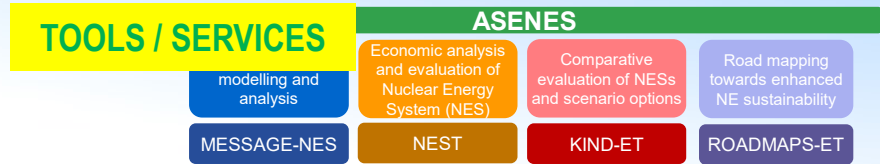

2. Innovations:
Innovative nuclear energy technologies and institutional arrangements

Transportable NPP
Akademik Lomonosov

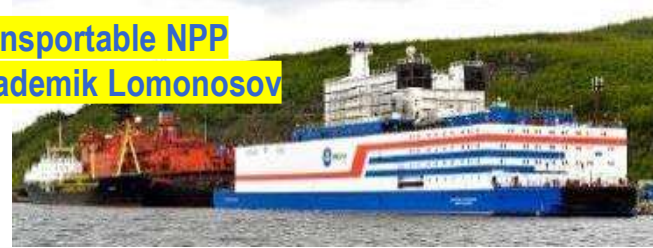

Fusion Studies



3. Sustainability Assessments & Strategies:
Nuclear Energy System Assessments (NESA) for sustainability

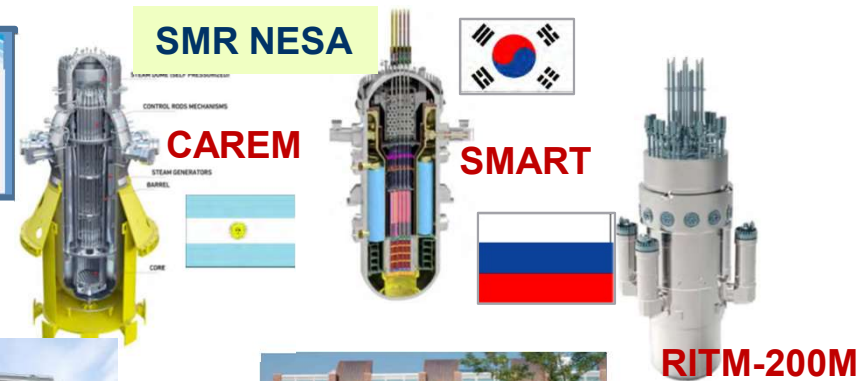
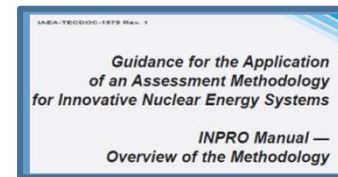

4. Dialogue and Outreach:
– Dialogue forums (DF)
– Training



Using the INPRO Methodology for Master Programmes at Universities

INPRO Area “Global scenarios”



The objective of the INPRO Area (Task) “**Global scenarios**” is to develop global and regional nuclear energy scenarios, using developed scientific-technical analysis tools that lead to a **global vision of sustainable nuclear energy development** in the current century and beyond

Over the past decade this task has successfully implemented a number of collaborative projects with broad participation of Member States – INPRO Members targeted at providing the support to interested Member States **in formulating national strategies for enhancing nuclear energy sustainability**



INPRO

International Project on
Innovative Nuclear Reactors
and Fuel Cycles

International Architecture of Innovative Nuclear Power and Nuclear Fuel Cycle

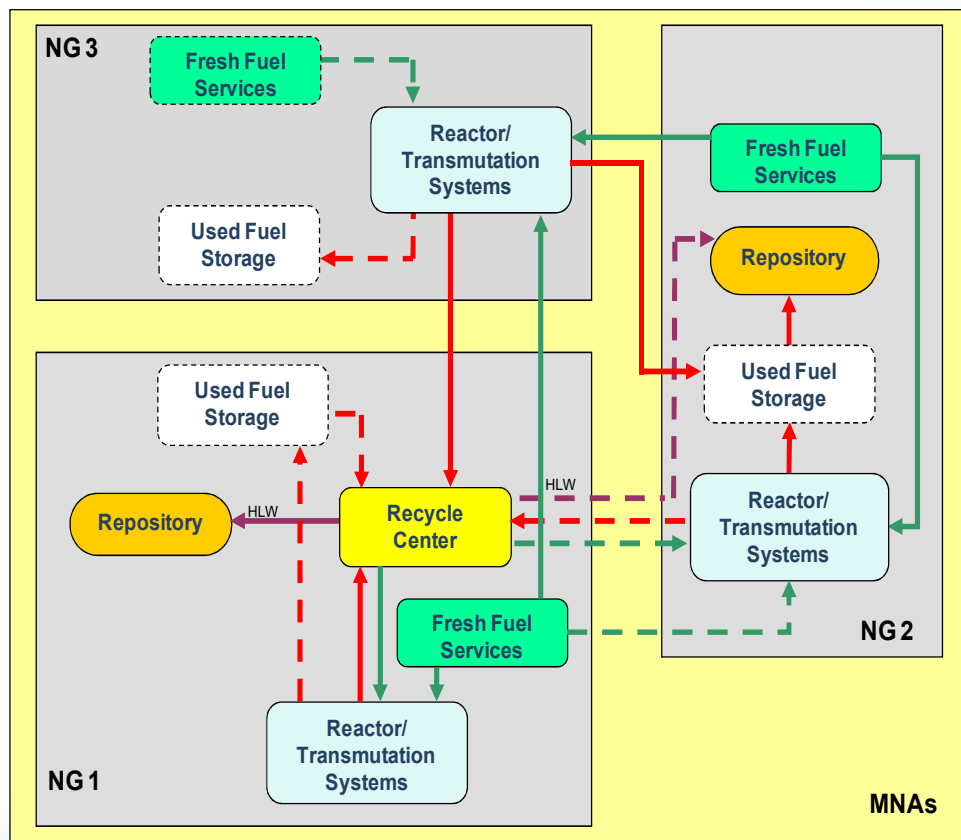
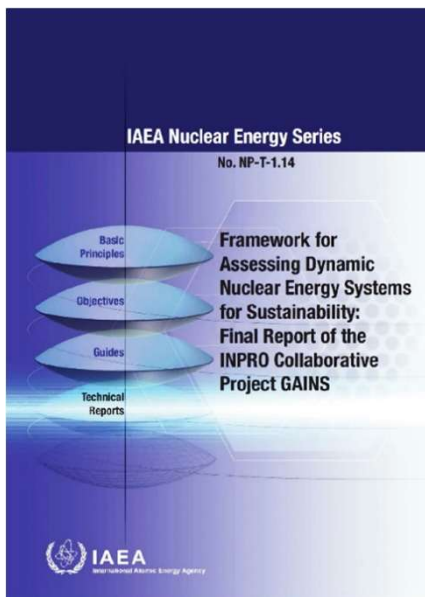

➤ GAINS project - transition scenarios to future nuclear energy systems

➤ The most important element is a heterogeneous world model with different policies regarding NFC front-end and back-end

➤ **NG1 (technology holders)** - Recycle used fuel

➤ **NG2 (technology users)** - Either directly dispose used fuel or to reprocess used fuel abroad

➤ **NG3 (newcomers)** - Use imported fresh fuel 1) Send used fuel abroad for either disposal or recycle or 2) Back-end strategy is undecided

Global Scenarios Activities

INPRO
Collaborative
Projects

Methods,
Tools,
Publications

Service to
MSs: ASENES
Package

GAINS - Global Architecture of Innovative Nuclear Energy Systems with Thermal and Fast Reactors and a Closed Fuel Cycle

SYNERGIES - Synergistic Nuclear Energy Regional Group Interactions Evaluated for Sustainability

KIND/CENESO - Key Indicators for Innovative Nuclear Energy Systems

ROADMAPS - Roadmaps for a Transition to Globally Sustainable Nuclear Energy Systems

Methods and software tools - internationally verified

Project publications - including case studies

ASENES - Analysis Support for Enhanced Nuclear Energy Sustainability

①

Collaborative projects

On-going Projects:

- ✓ ASENES SMR
- ✓ STEP FORWARD

②

INPRO Advisory Service

INPRO Methods and Tools

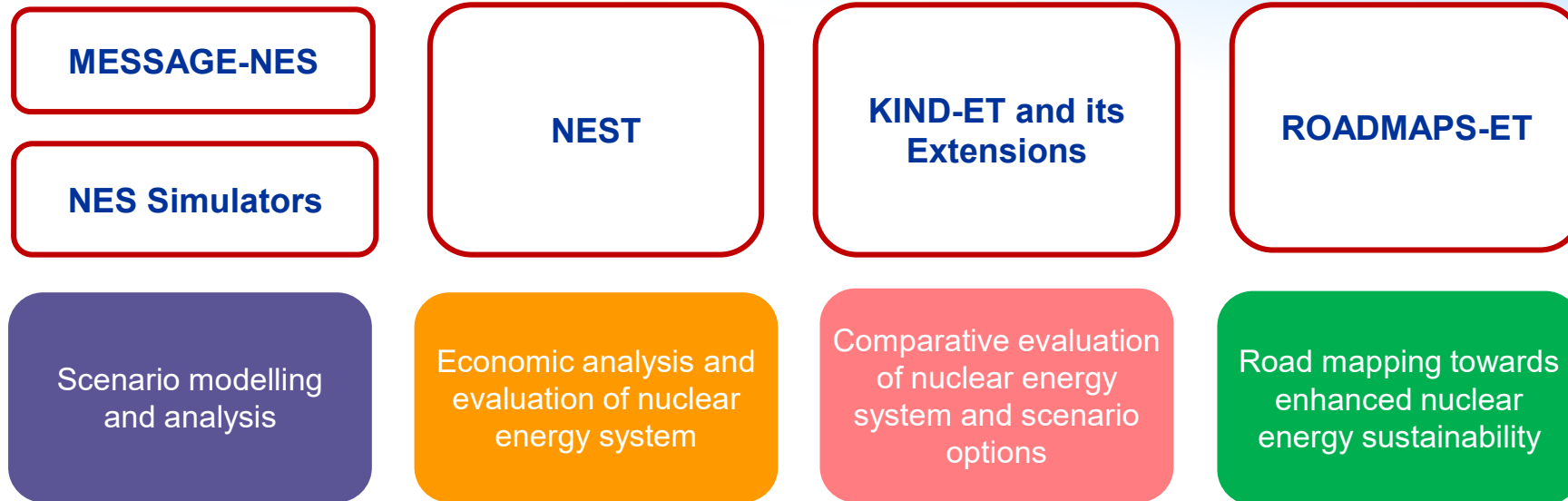

- ❑ **MESSAGE-NES:** Modelling material flows and cooperation amongst countries
- ❑ **NES SIMULATORS:** Simplified estimate mass flow and economic indicators
- ❑ **NEST:** Calculates LUEC and other economic figures for NPPs
- ❑ **KIND-ET and its extensions:** Comparison of NESs and non-nuclear energy options, using key factors important for decision making
- ❑ **ROADMAPS-ET:** Structured mapping of actions and timeframes

Task 2: Innovations

Investigate **innovative** nuclear energy (NE) **technologies** and institutional arrangements to support sustainable NE development

- Transportable / **Factory Fuelled SMRs**
- Institutional and Legal Impediments for Prospective Deployment of **Fusion** Facilities
- Cooperative Approaches to the **Back-end** of the Nuclear Fuel Cycle: Drivers and Institutional, Economic and Legal Impediments
- **Waste** from Innovative Reactors and Fuel Cycles (WIRAF)
- INPRO Case Study on **Hydrogen** Systems: Drivers and Institutional, Economic and Legal Impediments
- Collaborative Project **FRAMES**

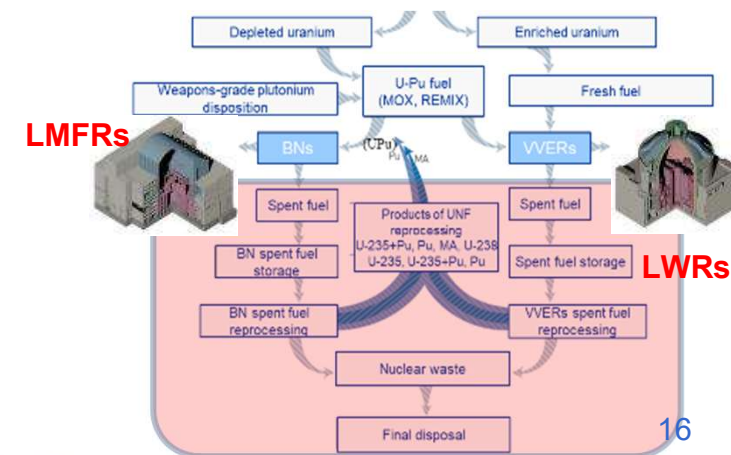
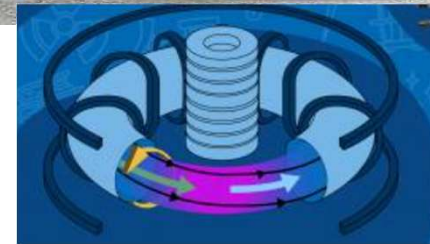

Task 3: NESAs and Strategies

- Nuclear Energy System Assessment: NESAs
- Updating INPRO Methodology Manuals
- Introduction to INPRO Methodology
- INPRO Support Package - Wiki

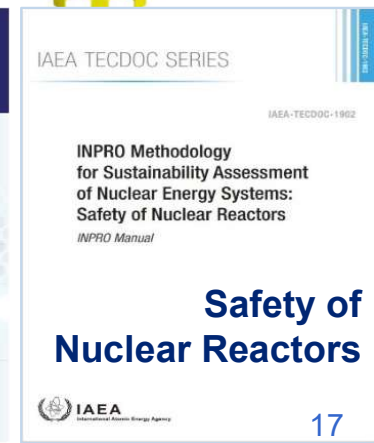
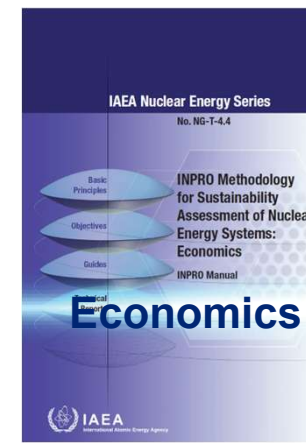
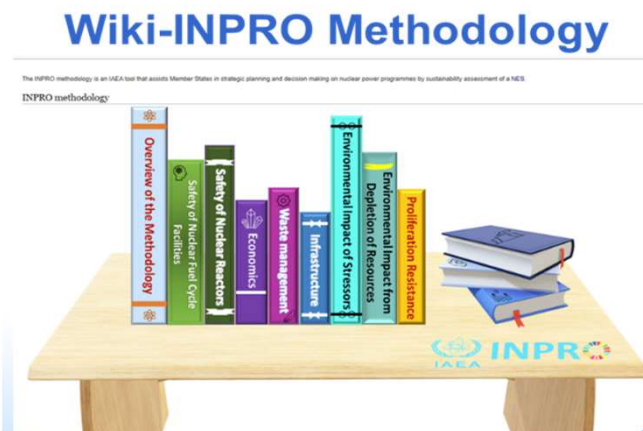
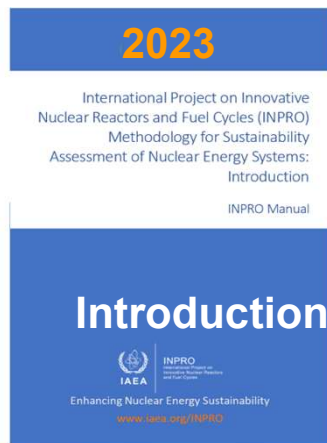
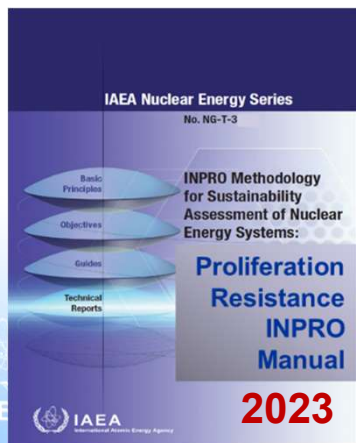
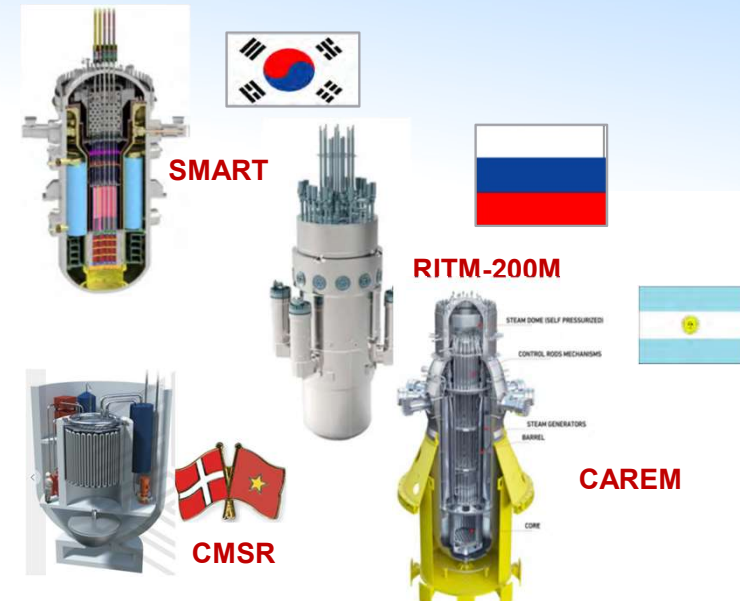

Task 4: Dialogue and Outreach

Dialogue Forums:

- 21st Deployment of SMRs to Support SDG (Russia) – Aug 2023
- 22nd Nuclear Energy Innovations (RoK) – Jeju Island, 20-24 May 2024
- 23rd Nuclear Energy Innovations to Support Net-Zero Transition – Vienna, 30.10-01.11, 2024
- 24th Sustainable Deployment of Floating NPPs for Transitioning to NetZero –Vienna, 19-23.05.2025
- 25th Africa's Dialogue Forum 17 - 21 November 2025 - Nairobi, Kenya
- 26th INPRO DF on Deployment of Nuclear Energy Systems for Applications Beyond Electricity, 24-28 August 2026, Bangkok, Thailand**



INPRO Training

Joint ICTP-INPRO Schools June 2023, July 2024, Sept.2025, [Aug.2026](#) (Trieste, Italy); Regional INPRO Schools: Uzbekistan (April 2024), Hungary (June 2025), [Rep.Korea \(July 2026\)](#), [Kazakhstan \(Sept.2026\)](#).

TC training on NESAs for SMR October 2023, NESAs Training for Chinese experts, training for Viet Nam – 2023-25.

Curriculum Development, support university Master's programme, incorporating INPRO methodology



Historical Perspective of INPRO SMR Activities



2000s-2010s

Prospective role of SMRs, overall considerations:

- First studies of TNPP – some legal gaps
- Request by MSs through GC resolutions to continue studies
- INPRO Dialog Forums on SMR Role (2011, 2013)

2015- 2020

Study on proliferation resistance of innovative SMRs,

Study of specific cases of TNPP :

- Recommendation for further IAEA studies of Legal aspects, Nuclear Safety and Security approaches and others
- INPRO Dialog Forums on SMR (2019)

Current

Assessments and Strategies:

- ASENES (Modelling and Analysis) – “Sustainable Deployment of SMRs”
- NESAs on SMRs with some designers
- Dialogue Forums: 21st, 22nd, 24th

Training: Strategic Planning for Sustainable Nuclear Energy (with SMR)



INPRO

International Project on Innovative Nuclear Reactors and Fuel Cycles

Transportable NPP (TNPP) Studies by INPRO

- First study (Preliminary): 2008-2013, IAEA Nuclear Energy Series, No. NG-T-3.5
- Issues considered: Infrastructure, safeguards, legal, nuclear: safety, security, & liability



- **Collaborative Project:** “INPRO Case Study on Deployment of Factory Fuelled Small Modular Reactors (SMR)” – TNPP-2

- Three cases selected for analysis:

1. submersible SMR
2. floating SMR
3. land-based SMR

- **SMRs loaded with nuclear fuel and transported to Host State for operation**

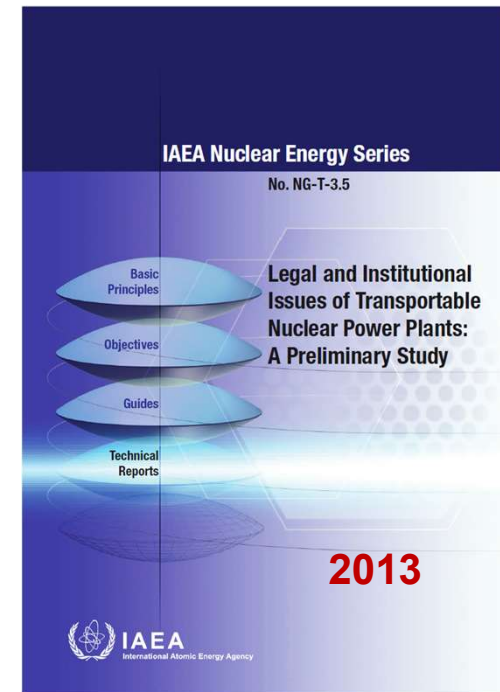
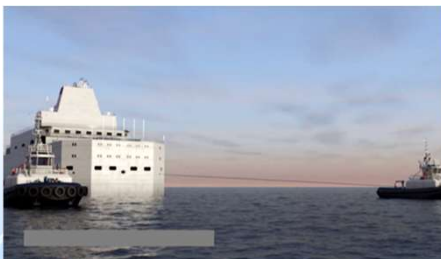

Sustainable Deployment of SMRs (ASENES SMR)

Title of Activity: Sustainable Deployment Scenarios for Small Modular Reactors: A Study Supported by the INPRO Service “Analysis Support for Enhanced Nuclear Energy Sustainability” [ASENES SMR]

Objective: Provide formulation of promising scenarios and success factors for the deployment of sustainable nuclear energy system with SMRs, including the prospective models of cooperation

Deliverable: TECDOC (under preparation)

Timeframe: 2020 – 2026

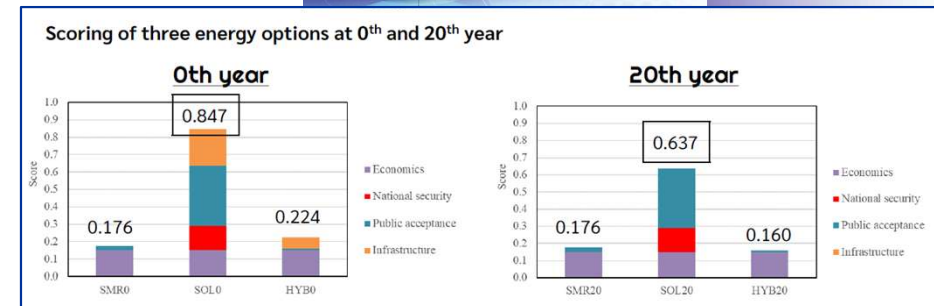
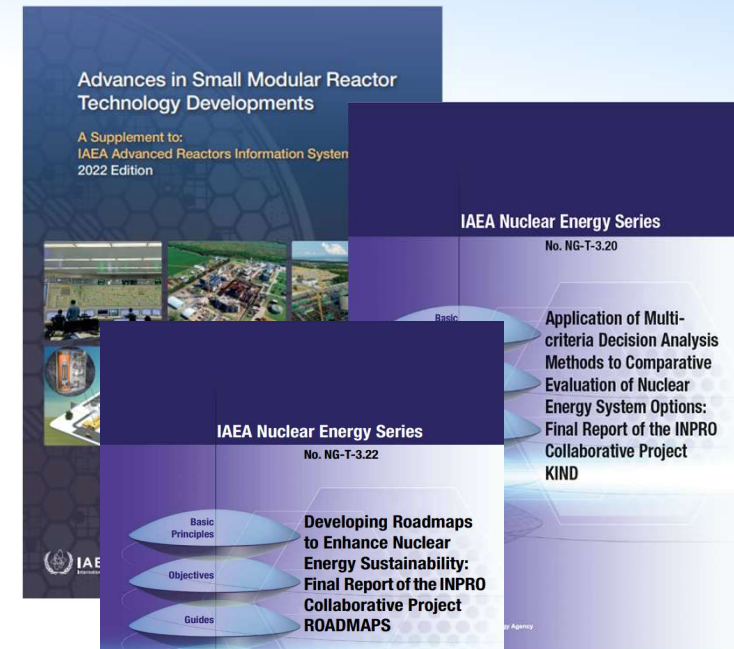

NESA SMR with Member States

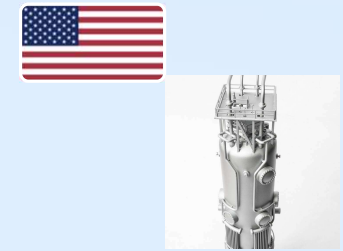
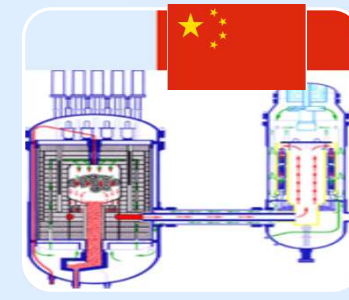
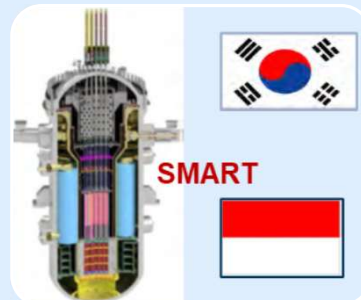

Viet Nam with
Saltfoss
CMR
(Denmark)
Full Scope
NESA

Indonesia with
SMART
(Korea)
Full Scope
NESA

Russia
RITM200M
Limited Scope
NESA
Economics
Safety

China
micro-HTGR
Full Scope
NESA

Hopeful:
NuScale
VOYGR

The object of study



innovative integral RITM-200M reactor plants, analogues of which are currently used on multi-purpose nuclear-powered icebreakers

Ship hull optimization

FPU
Akademik Lomonosov

Optimized
Floating Power Unit
(OFPU)

144.2 m	LENGTH	112 m
30 m	BEAM	30 m
5.6 m	DRAFT	5 m
21,000 t	DISPLACEMENT	16,680 t

2 reactor plants

RITM-200M

service life

up to 60 years

refueling interval

up to 10 years

electric power

100 MW

reactor plant thermal power

up to 198 MW

OPTIMIZED FLOATING POWER UNIT (OFPU)

is a non-self-propelled berth-connected ship fitted with a double bottom and double sides all along the hull, a well-developed superstructure stretching all along the ship, a reactor compartment amidships and a crew accommodation block in the fore part.

**according to the preliminary design results*



FRAMES – Collaborative Project

Purpose: *investigating and analysing NES for grid integration of intermittent renewables and advanced nuclear technologies (including SMRs)*

Released FRAMES V1.0 in October 2025

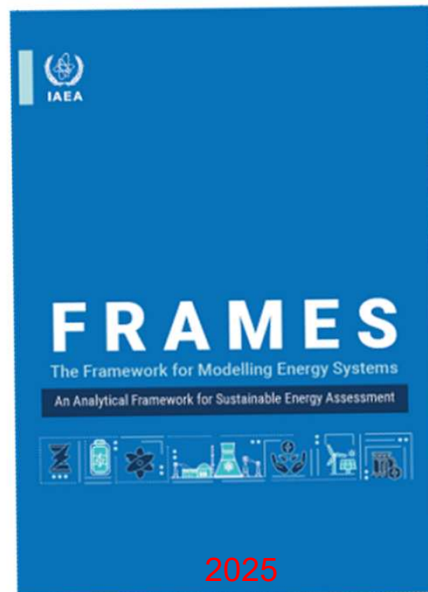

Activities for 2026

- FRAMES Model description (2026)
- Finalizing ToR Phase II
- Training
- Developing and analyzing national and regional scenarios
- **TM FRAMES Phase II 28 Sep – 1 Oct 2026**

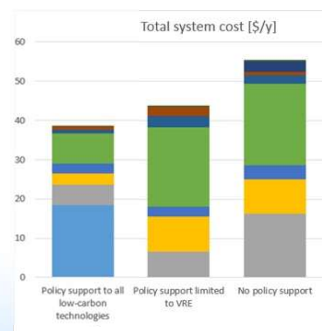
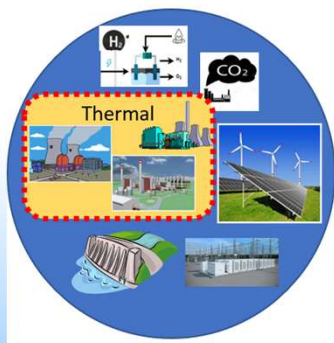

Fossil-to-Nuclear Sustainable Transition Assessment (F2N)

Launched (Oct 2025): Collaborative project on Assessing Sustainability for Transitioning Fossil Fuel Plants to Nuclear Energy Systems

- Improve air quality, public health and environment
- Energy security
- Job creation
- Economic growth
- Transition with SMRs

Activities for 2026

- Finalizing ToR
- Identifying collaborative project participants
- Establishing WG

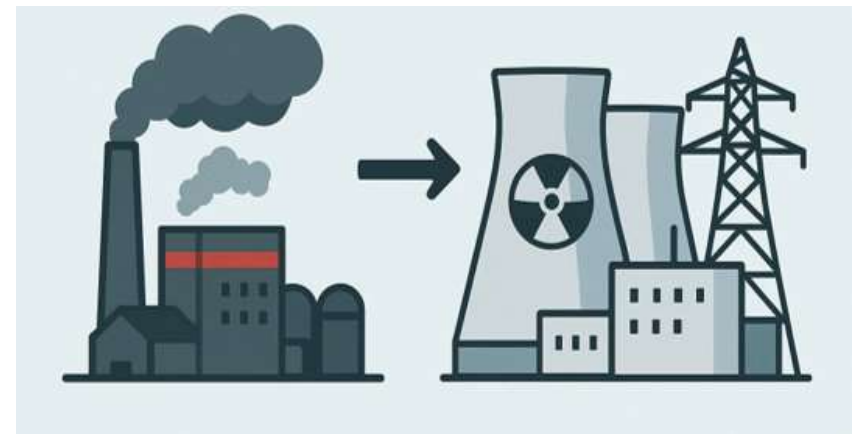

INPRO Advisory Services



- Advisory Services / Missions
 - Nuclear Energy System Assessment (NESA)
 - Scenario Modelling & Analysis (former title - ASENES)
- Capacity Building
 - Dialogue Forums
 - Schools, Trainings and Universities Programmes
- Collaborative Projects
 - Global Scenario Modelling
 - Assessment of Innovative Fuel Cycles

INPRO Scope (current vision)

An IAEA forward looking project that integrates all areas important to the sustainability of nuclear energy

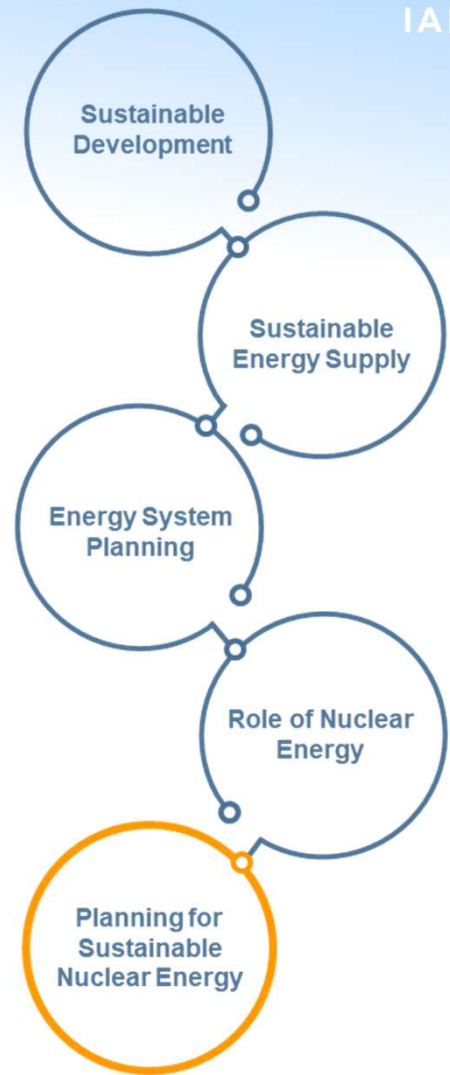
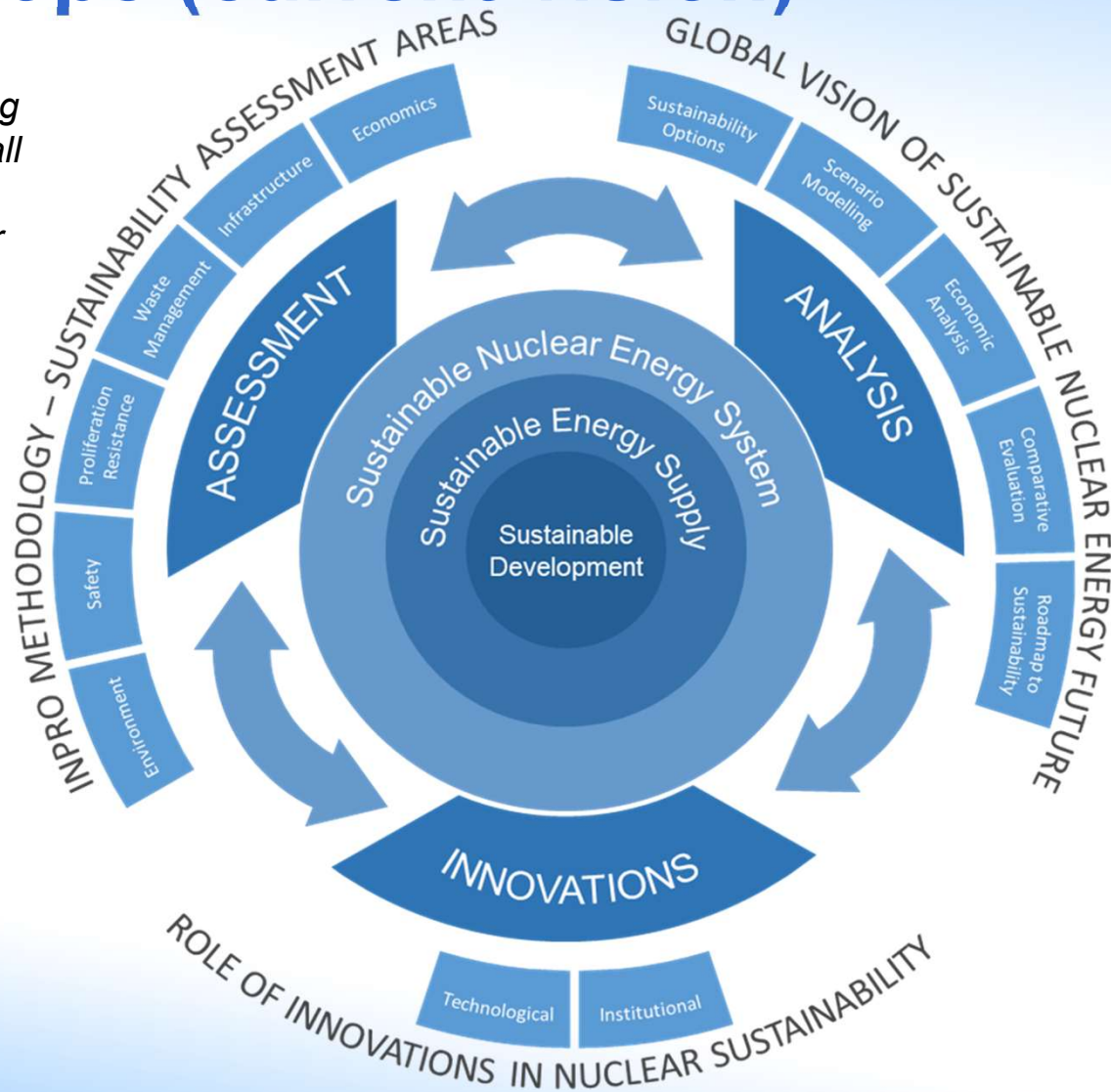

Conclusions:

INPRO methodology and INPRO tools are valid instruments for:

- **Strategic planning of Nuclear power Systems for Member States with enhanced international and regional cooperation**
- **Systematic promotion of nuclear innovations and understanding of their roles in sustainable development**



IAEA

International Atomic Energy Agency
Atoms for Peace and Development

Thank you!



IAEA

INPRO

International Project on
Innovative Nuclear Reactors
and Fuel Cycles



Nuclear
Energy

INPRO

INTERNATIONAL PROJECT ON INNOVATIVE
NUCLEAR REACTORS AND FUEL CYCLES

INTERNATIONAL PROJECT ON INNOVATIVE NUCLEAR REACTORS AND FUEL CYCLES

- *Developing sustainable nuclear energy scenarios*
- *Investigating institutional and technical innovations*
- *Assessing the sustainability of nuclear energy systems*
- *Facilitating dialogue between technology holders and users*



www.iaea.org/inpro



The presentation contains illustrations prepared by INPRO and used for public lectures. Special thanks IAEA INPRO staff including Ms.C.Scherer, Ms.T. Mai Vu, Ms.J.M.C.Johari, Mr.M.Gladyshev for the materials and advices for the presentation.