

**WORKSHOP ON
NUCLEAR POWER PLANT SIMULATORS**

**INTRODUCTION TO CANDU
SYSTEMS AND OPERATION**

Dr. G. T. BEREZNAI

and Dr. G. HARVEL

**Faculty of Energy Systems and Nuclear Science,
University of Ontario Institute of Technology, Oshawa,
Ontario, Canada (2011)**

INTRODUCTION TO CANDU SYSTEMS and OPERATION

SESSION 1: OVERALL UNIT

SESSION 2: REACTOR

SESSION 3: HEAT TRANSPORT

SESSION 4: STEAM, TURBINE & FEEDWATER

SESSION 5: ADVANCED CANDU REACTOR

Lecture Notes

prepared by:

Dr. George Bereznai

Dean, Energy Systems and
Nuclear Science, at the University of
Ontario Institute of Technology,
Canada

george.bereznai@uoit.ca

glenn.harvel@uoit.ca

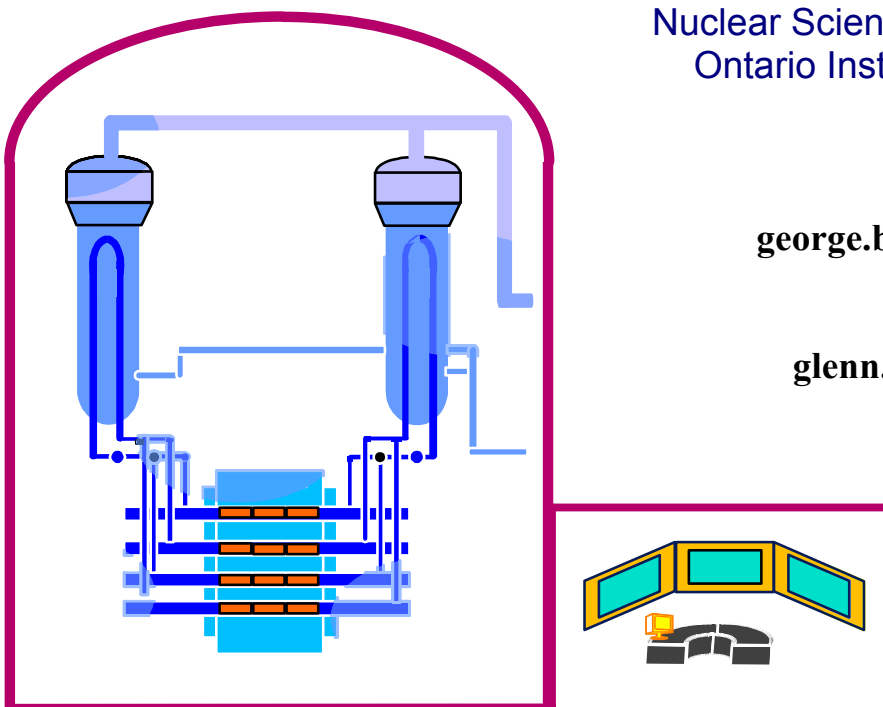

SESSION 1:

1.	INTRODUCTION	page 2
2.	MAJOR CANDU SYSTEMS	page 3
3.	NUCLEAR STEAM SUPPLY SYSTEM	page 4
4.	FUEL HANDLING AND STORAGE	page 5
5.	MODERATOR SYSTEMS	page 6
6.	HEAT TRANSPORT SYSTEM	page 7
7.	STEAM GENERATOR AND MAIN STEAM SYSTEMS	page 8
8.	FEEDWATER SYSTEM	page 9
9.	TURBINE, GENERATOR, CONDENSATE AND FEEDHEATING SYSTEMS	page 10
10.	REACTOR SHUTDOWN SYSTEMS (SDS#1 AND SDS#2)	page 11
11.	NUCLEAR POWER PLANT SIMPLIFIED SCHEMATIC	page 12
12.	NORMAL AND ALTERNATE MODES OF UNIT CONTROL	page 13
13.	SIMPLIFIED BLOCK DIAGRAM OF THE MAIN PLANT SYSTEMS	page 14
14.	COMPUTERIZED PLANT CONTROL SYSTEMS	page 15
15.	CANDU 9 OPERATING CHARACTERISTICS	page 16



1. INTRODUCTION

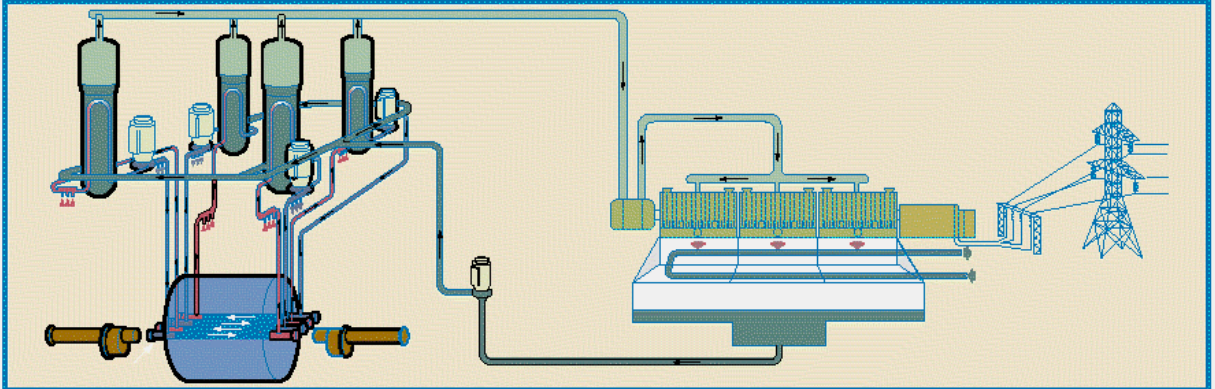

CANDU Overview

2. MAJOR CANDU SYSTEMS

The portion of this workshop that deals with CANDU Systems and Operations is organized into four Sessions. Each Session encompasses a major portion of a CANDU unit, and covers a system or a group of functionally related systems. The role and relation of the systems discussed in a Session to the overall generating unit is introduced and related to the rest of the Workshop with the aid of the "Course Map" shown on the diagram.

Item 1. In Session 1 we look at the Overall Nuclear Electric Generating Unit as an entity. I am using the yellow background in the diagram to illustrate what is meant by the term Overall Unit: it is the complete physical plant that is involved in having the energy in the nuclear fuel converted through various processes to electrical energy. This Session concentrates on the main building blocks that make up an operating unit and the interactions between these blocks.

Each of the subsequent Sessions will look at the main systems and groups of systems of the overall unit.

Item 2. In the second Session we look at the main components of the reactor and of the reactor regulating system.

We will see how the natural uranium fuel is held in the fuel channels and how it is cooled by the heavy water of the heat transport system. We will also look at the types of instruments and techniques that are used to measure the power produced by the reactor, the control algorithms that compare the power measurements with the desired power level, and how the devices used to control the nuclear reaction change the power output of the reactor.

Using the simulator, you will perform several reactor operations under both normal and malfunction conditions, and gain a good appreciation of the rate and magnitude of power level changes, and the mechanisms through which the regulating system control reactor power.

Item 3. Session 3 is about the Heat Transport System, which in CANDUs uses heavy water to transfer the energy released by the nuclear fuel in the reactor to generate steam to drive the turbine and generator. You will learn the key features of the Main Circuit, how the pressure and inventory of heavy water is controlled in the heat transport system. It is quite a complex system, and it is shown in sufficient detail on the simulator to let you do some interesting exercises under normal as well as several malfunction conditions.

Item 4. Session 4 is about the systems that are often referred to collectively as the Balance of Plant: the steam, turbine and feedwater systems. Important control systems are associated with these, including the steam generator pressure and level control systems and the turbine control system.

On the simulator a variety of malfunctions involving each of the above systems will be dealt with.

2. MAJOR CANDU SYSTEMS

- ▶ Session 1: Overall Unit
- ▶ Session 2: Reactor
- ▶ Session 3: Heat Transport
- ▶ Session 4: Steam, Turbine & Feedwater

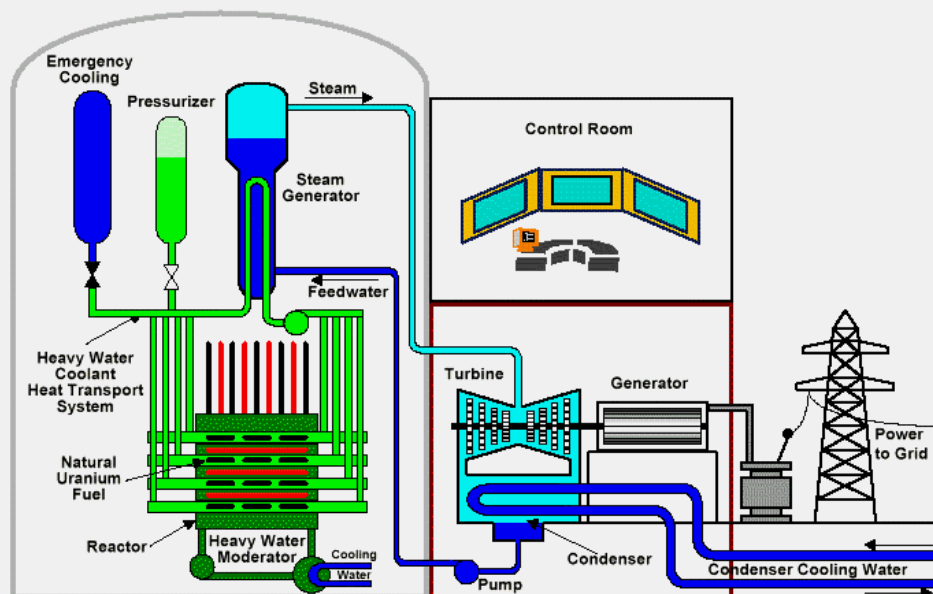

3. NUCLEAR STEAM SUPPLY SYSTEM

The diagram shows the following major components of the CANDU Nuclear Steam Supply System, the Reactor, Fuel Handling, Heat Transport, Feedwater and Steam systems. The Fuel Handling System provides fresh fuel and removes spent fuel from the Reactor. The heat generated in the Reactor from the fissioning of nuclei in the fuel is removed by the Heat Transport system heavy water and is transferred in the Steam generators to the Feedwater, which is ordinary light water, and the resultant steam is supplied to the Turbine.

(1) The Reactor Assembly consists of (a) the Calandria, which is a stainless steel horizontal cylindrical vessel that holds the heavy water moderator and reflector. There are hundreds of Fuel Channels installed in the Calandria vessel and supported by the End Shield that close off the two ends of the Calandria. Arrow (b) points to one of the Fuel Channels, each of which consists of a calandria tube that surrounds a pressure tube that contains 12 natural uranium fuel bundles and carries the pressurized heavy water heat transport coolant. There are 380 such fuel channels in a CANDU 6 reactor, and 480 in a CANDU 9 reactor.

The Calandria is surrounded by a Shield Assembly, indicated by arrow (3), made of concrete and steel, and containing light water. There are In-core Flux Detectors installed from the top of the Calandria, and Ion Chambers that are housed at the side of the Calandria, as indicated by arrows (d). The Reactivity Mechanisms are shown by arrow (e) as being inserted from the top of the calandria.

(2) The Heat Transport System consists of two main loops, identified by the labels on the diagram. Each of the two loops has a 'hot-leg' as indicated by arrows (b1) and (b2), a pair of boilers in each loop, at arrows (c1) and (c2), and a 'cold-leg' shown at (d1) and (d2) to complete each loop. The actual system is of course much more complicated, with two circulating pumps per loop, reactor inlet and outlet headers and piping connections to every pressure tube. The heat transport coolant heavy water is continuously circulated through each loop, carrying the heat from the reactor to the steam generators and back to the reactor. The coolant is under high pressure so that only a small amount of boiling takes place near the outlets of the hottest fuel channels. We will look at the pressure and inventory control system, and other heat transport auxiliary systems later in this Session.

(3) The Steam Generators transfer the heat from the heavy water coolant of the heat transport system on the primary side to the light water on the secondary side to form steam. The steam is sent to the Balance Of Plant systems, most of it to the Turbine, and a much smaller amount to the Feed Heating system. After passing through the Turbine the steam is condensed in the Condenser, and the water is subsequently raised in temperature and pressure before returning it to the Steam Generators in the form of Feedwater.

(4) The Fuel Handling System takes fresh fuel bundles, as indicated by arrow (a) and feeds them into the designated fuel channel. After a residency time of approximately one year, the spent fuel bundles, indicated by arrow (b) are removed from the fuel channel by the computerized remote controlled fuel handling system, and transfers them to the irradiated fuel bay, where the bundles will reside for at least seven years, before they can be transferred to dry storage.

3. NUCLEAR STEAM SUPPLY SYSTEM

- ▶▶ (1) Reactor Assembly
 - (a) Calandria
 - (b) Fuel channels
 - (c) Shielding
 - (d) Flux detectors
 - (e) Reactivity Mechanisms
- ▶▶ (2) Heat Transport System
 - (a) Two Loops
 - (b) 'Hot Leg'
 - (c) Steam Generators
 - (d) 'Cold Leg'
- ▶▶ (3) Feedwater and Steam
- ▶▶ (4) Fuel Handling
 - (a) Fresh Fuel
 - (b) Spent Fuel

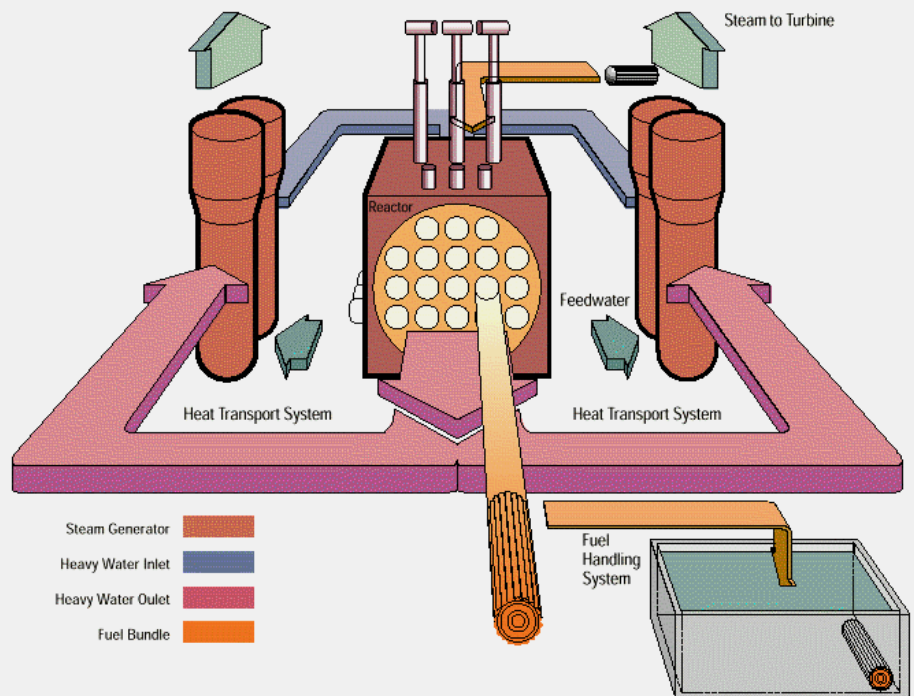

4. FUEL HANDLING AND STORAGE

Typical refuelling operations require that each day eight fuel bundles are replaced in one or two channels. Apart from the loading of new fuel bundles into the magazines of the new fuel ports, all other operations are controlled remotely from the control room using digital computers.

The Fuel Handling and Storage Facilities to support this operation include:

- (1) receiving, storing, inspecting and loading new fuel into fuelling machines;
- (2) on-line removal of spent fuel and insertion of fresh fuel;
- (3) cooling of irradiated fuel during its removal and transfer to storage bays;
- (4) underwater storage of irradiated fuel until it can be transferred to dry storage (at least six years).

(1) New fuel is received, inspected and stored in the New Fuel Storage room that is located in the Service Building.

When required for use in the reactor, the fuel bundles are transferred to the New Fuel Transfer Room in the Reactor Building. The fuel bundles, typically eight at a time, are loaded manually into one of the two magazines of the new fuel port.

Transfer of the new fuel bundles into the fuelling machine that is designated to hold the fresh fuel is controlled remotely.

(2) Fuelling Machines

Two fuelling machines, connected to either end of a fuel channel, are needed to change the fuel in a CANDU reactor.

One fuelling machine inserts new fuel bundles into the fuel channel, in the same direction as the flow of coolant in that channel, left to right in this diagram. The irradiated or 'spent' fuel bundles are pushed into the other fuelling machine at the downstream end of the fuel channel. Typically either four or more often eight of the 12 fuel bundles in a fuel channel are exchanged during a refuelling operation.

Either of the two fuelling machines can load fresh fuel or receive spent fuel. The direction of loading, and hence the role that each machine will have, depends on the direction of coolant flow in the fuel channel being refuelled, since the flow direction alternates between adjacent channels.

(3) Irradiated Fuel

Following the placement of the irradiated fuel bundles in the fuelling machine the fuel channel is reclosed. The fuelling machine then moves to the Discharge Port, where the fuel bundles are transferred into an elevator, which lowers them into the water filled Discharge Bay.

The irradiated fuel bundles are moved under water through a Transfer Canal into the Reception Bay, where they are loaded onto storage trays or baskets and passed into the Irradiated Fuel Storage Bay.

All the transfer operations from the Fuelling Machine to the Irradiated Fuel Storage Bay take place under water, ensuring that the fuel is cooled at all times during removal and transfer, to prevent fuel overheating and possible damage to the bundles.

(4) Irradiated Fuel Storage Bay

Irradiated fuel bundles are stored in the Irradiated Fuel Storage Bay for a minimum of six years before they can be transferred to dry storage. The storage volume of the bays has sufficient capacity of a minimum of 10 years' accumulation of irradiated fuel. Operations in the Storage Bays are carried out under water, using special tools aided by cranes and hoists.

Defective fuel is placed into protective cans before transfer to the Defective Fuel Bay, in order to limit the spread of contamination.

Because CANDU uses natural uranium fuel, neither the new nor the irradiated fuel can achieve criticality in air or in ordinary light water, regardless of the storage configuration.

4. FUEL HANDLING AND STORAGE

- (1) New Fuel Storage
- (2) Fuelling Machines
- (3) Irradiated Fuel
- (4) Irradiated Fuel Storage Bay

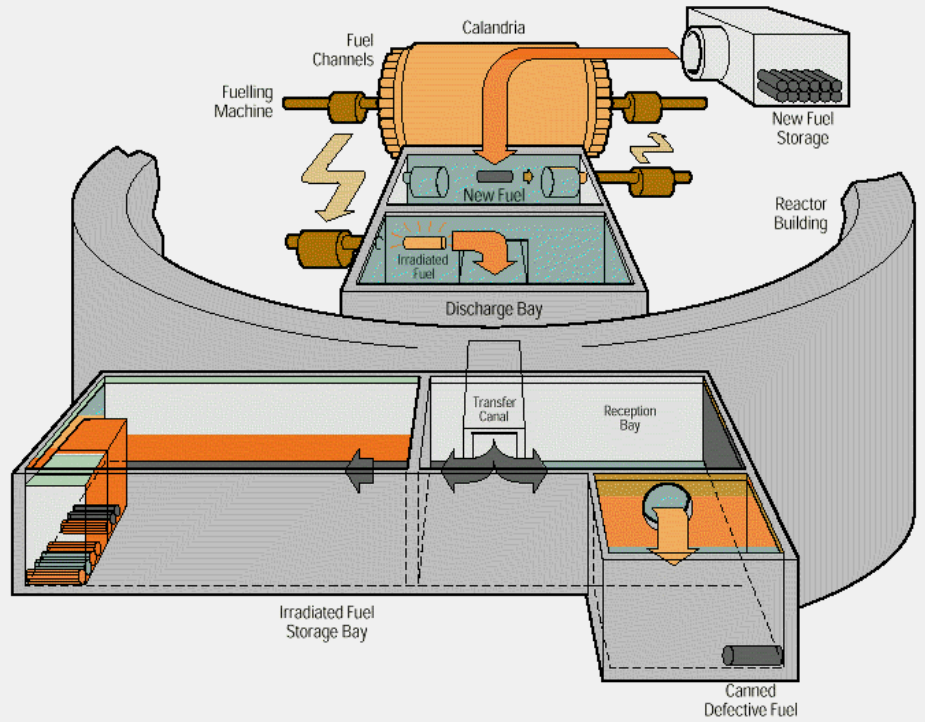

5. MODERATOR SYSTEMS

All CANDU reactors use heavy water as the moderator, in a system that is completely separate from the reactor coolant heavy water. About 4% of the reactor thermal power appears in the moderator, due to gamma radiation, the slowing down of fast neutrons, and heat transferred from the fuel channels.

The Moderator Systems consist of the Main Circuit, which circulates the heavy water through the calandria and heat exchangers to remove the heat generated in the moderator during reactor operation.

The operating pressure at the moderator free surface near the top of the Calandria is slightly above atmospheric. A Helium Cover Gas system provides an inert atmosphere at this surface.

Liquid Poisons can be added to the moderator for reactor control and shutdown, and removed via the Purification system.

A Heavy Water Collection system collects any heavy water that leaks from the moderator and associated systems.

(1) The Moderator Main Circuit, removes the heat generated in the moderator during reactor operation and maintains the moderator level in the Calandria. The Calandria is normally full, and the Head Tank is designed to maintain the level within the required range by allowing moderator swell and shrink that result from temperature fluctuations. The pressures and temperatures in the Calandria are kept at slightly above atmospheric conditions.

Two 100% capacity pumps circulate the heavy water moderator through the calandria and two heat exchangers. The moderator heat is rejected to the Recirculated Cooling Water (RCW) System.

The heavy water in the Calandria provides a heat sink in the unlikely event of a loss of coolant accident coincident with failure of emergency core cooling.

(2) A Cover Gas System above the free moderator surface is needed to prevent moisture in the air down-grading the heavy water concentration, and the accumulation of a potentially explosive mixture of deuterium and oxygen gases that result from the radiolysis of the heavy water.

Helium, which is chemically inert and not activated by neutron irradiation, is used as the cover gas. The system controls the concentration of deuterium and oxygen gasses by catalytically recombining them to re-form heavy water.

The Cover Gas System includes two compressors and two recombination units through which the cover gas is circulated.

- (3) The Liquid Poison System adds negative reactivity to the moderator when required, such as:
- to provide a means of reactivity control by adding dissolved poison to the moderator;
 - to provide a means of rapid reactor shutdown by injection of poison into the moderator; this is done by Reactor Shutdown System (SDS) #2;
 - to provide a means of guarantying reactor shutdown by dissolving excess poison into the moderator.

The liquid poisons employed are boron as boric anhydride, and gadolinium as gadolinium nitrate, dissolved in D₂O.

- (4) The Moderator Purification System has the following main functions:
- maintain the purity of heavy water so that the excess production of deuterium and oxygen gases through radiolysis is minimized;
 - minimize the corrosion of components by removing impurities and controlling the pD level of the heavy water;
 - control reactivity by reducing the concentration of dissolved poisons boron and gadolinium in the moderator, under the unit operator's control;
 - remove the excess gadolinium that was injected in response to a Reactor Shutdown System #2 trip, once the conditions for restarting the unit have been established.

The system consists of a filter and ion exchanger columns.

(5) The Moderator D₂O Collection System collects any heavy water leakage from the moderator and associated systems and transfers it into the heavy water management systems for Cleanup and Upgrading.

- 5. MODERATOR SYSTEMS**
- (1) Main Circuit
 - (2) Cover Gas
 - (3) Liquid Poison
 - (4) Purification
 - (5) D₂O Collection

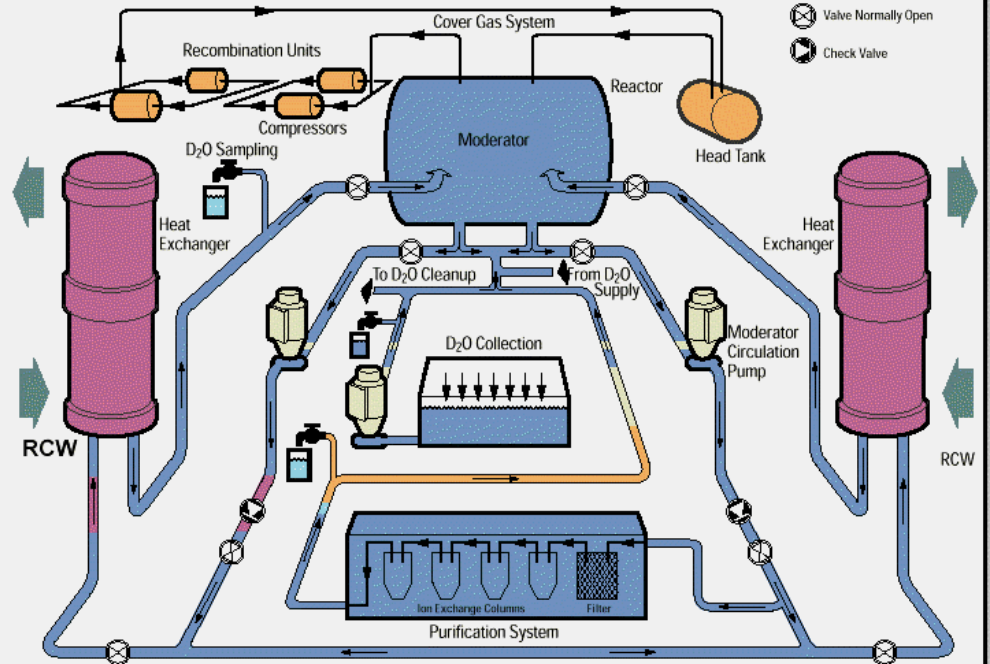

6. HEAT TRANSPORT SYSTEM

The Heat Transport Main Circuit uses pressurized heavy water to remove the heat produced in the reactor. The heat is carried to the steam generators where it boils the light water on the secondary side to produce steam.

The Heat Transport system must provide for the continuous cooling of the fuel, and it has to contain any fission products that may be released from the fuel.

The Main circuit, as shown on the diagram, consists of two loops, each with a figure of eight coolant flow pattern. Reactor inlet and outlet headers connect the fuel channels through feeder pipes to the rest of the main circuit. There are four steam generators of the vertical U-tube type with an integral preheating section. The four heat transport system pumps are vertical single discharge, electric motor driven, centrifugal pumps with multi-stage mechanical shaft seals.

Under normal operating conditions the Pressurizer maintains the required system pressure.

No chemicals are added to the heat transport system for reactivity control.

(1) Two Loops

The Main Circuit, as shown on the diagram, consists of two loops. Only four representative channels are shown, two per loop, with the coolant flow in opposite directions as the two 'legs' of each loop pass through the Reactor. The illustration is indicative of the flow pattern for the actual number of fuel channels, since the coolant flow through the core is bi-directional, i.e. in opposite directions in adjacent fuel channels.

Each loop serves half of the reactor. The fuel channels are divided for this purpose about the vertical centre-plane of the reactor. Having a steam generator and a circulating pump at the 'ends' of each loop, the overall effect is a figure of eight coolant flow pattern. The arrows point to the circuit for Loop 1.

(2) The four Steam Generators transfer heat from the reactor coolant, contained on the steam generator primary side, to light water to produce steam on the secondary side. The CANDU 6 and 9 steam generators consist of an inverted vertical U-tube bundle in a cylindrical shell. Steam separating equipment is provided in the steam drum in the upper part of the shell. The steam leaving the steam generator has less than 0.25 percent moisture by weight.

Feedwater enters the baffled preheater section of the steam generator, and flows over the D2O outlet end of the U-tube bundle. Water at saturated temperature from the preheater mixes with recirculating water flowing over the hot leg section of the tube bundle.

(3) The four heat transport Main Circuit Pumps are vertical single discharge, centrifugal pumps with multi-stage mechanical shaft seals. Each pump is driven by a vertical, totally enclosed, air-water cooled squirrel cage induction motor.

The pump/motor unit has sufficient rotational inertia so that, on loss of motor power, the rate of coolant flow reduction matches the reactor power rundown following reactor trip. Natural circulation maintains fuel cooling after the pumps stop.

(4) Headers

Each pressure tube receives its coolant flow via a feeder pipe connected to a Reactor Inlet Header (RIH), and the coolant leaves the pressure tube via another feeder pipe connected to the Reactor Outlet Header (ROH). In CANDU 6 there are four RIH and four ROH, as shown in the diagram. The CANDU 9 design has combined two of the Inlet Headers, one on either end of the Reactor.

The feeders that connect each fuel channel to the reactor inlet and outlet headers are sized such that the coolant flow to each channel is proportional to channel power. The enthalpy increase of the coolant is therefore the same for each fuel channel assembly.

The operating pressure at the Reactor Outlet Header is 10 MPa. In order to maximize unit thermal efficiency, boiling in the core at high power is permitted, leading to an Reactor Outlet Header steam quality of up to 4% at full power.

6. HEAT TRANSPORT SYSTEM

- (1) Two Loops
- (2) Four Steam Generators
- (3) Four Main Circuit Pumps
- (4) Headers
- (5) Heat Transfer Path
- (6) Pressurizer

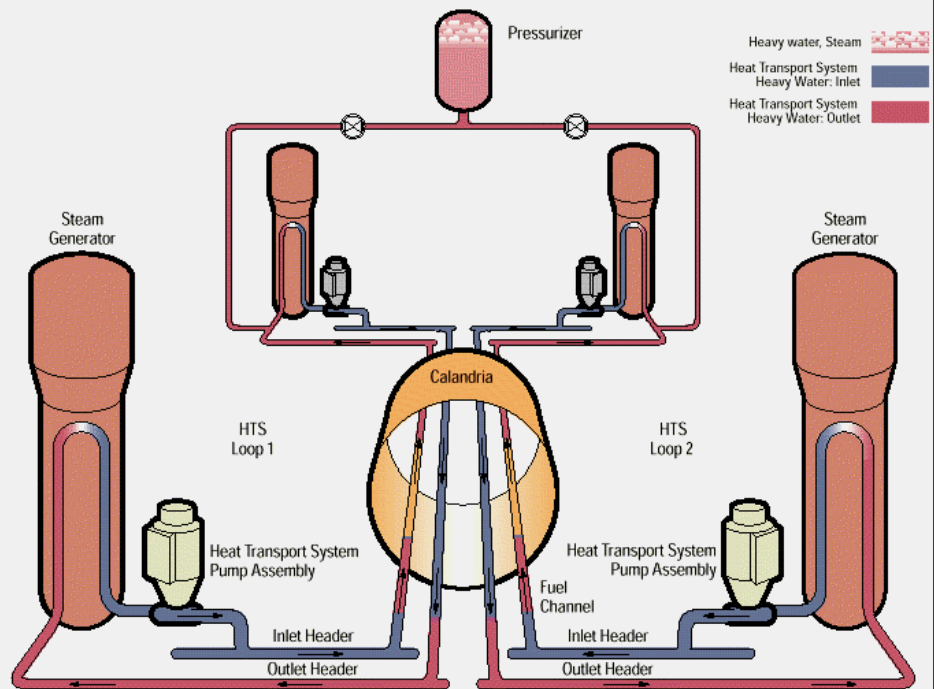

(5) Heat Transfer Path

Please refer to the arrow numbers shown on the diagram.

- (a) The coolant emerges hot, shown by red colour, from the fuel channels.
- (b) All the feeders from a quarter of the fuel channels are connected to the given ROH, from which the hot heavy water flows to the steam generators, where it transfers heat to the light water on the secondary side.
- (c) The once again cooled heavy water enters the Heat Transport Circulating pump, then flows to the RIH.
- (d) The RIH distributes the coolant to each of the feeder pipes connected to it, sending the coolant to the inlet of the fuel channels, flowing in the opposite direction from the earlier set.
- (e) The coolant is heated once again as it flows past the fuel, and emerges at the other end of the reactor, flowing through the ROH, the Steam Generator, and the Circulating pump.
- (f) The loop is completed with the coolant going through the RIH back to the first set of fuel channels.

(6) The Pressurizer maintains the required system pressure under normal operating conditions. The Pressurizer's liquid and steam are kept at saturation, and at a pressure that is slightly higher than the saturation conditions in the reactor outlet header at 100%FP.

Pressurizer and hence heat transport pressure can be raised by adding heat to the liquid via electric heaters, and the pressure can be reduced by bleeding steam out of the pressurizer.

During a reactor power increase the outlet header pressure rises as a result of the swell in the system. The level setpoint in the pressurizer increases automatically so that all the swell resulting from power increases is stored in the pressurizer.

The level in the pressurizer, and hence the heat transport system inventory, is normally controlled via the Heat Transport feed and bleed flows. In cases when the Pressurizer is isolated from the Main Circuit, the feed and bleed flows also control the system pressure.

7. STEAM GENERATOR AND MAIN STEAM SYSTEMS

The Steam Generator and Main Steam Systems include the four Steam Generators, the piping and valves that direct the flow of steam to the Turbine, to other steam loads, or to by-pass these loads when the need arises.

As discussed earlier, the heavy water reactor coolant of the Heat Transport System flows through hundreds of small inverted 'U' tube bundles in each of the four Steam Generators (only one shown in the diagram) and transfers heat to the light water supplied by the Feedwater System. The steam from the Steam Generators is fed by separate piping, called Steam Mains to the Turbine Steam Chest via the Turbine Stop Valves, and its flow is controlled by the Governor Valves.

When the turbine cannot accept the full steam flow, the excess steam can be discharged to the atmosphere or bypass the turbine by flowing directly to the condenser.

Over-pressure protection is provided by four Safety Relief Valves on each steam main.

- (1) Steam Flow Measurements are made in each of the four Steam Mains, and are used for:
 - (a) Input to the Reactor Regulating System for the computation of Reactor Thermal Power .
 - (b) Input to the Steam Generator Level Control program to control the opening of the Feedwater valves.
 - (c) Display by the Computerized Plant Display System and on the Control Room Panel Instruments.
- (2) There is a Main Steam Isolation Valve in each of the four Steam Mains. These are motorized valves that are normally open, and are closed remote-manually only after the reactor had been shut down. They are provided for the purpose of being able to isolate each Steam Generator from the rest of the system, typically in cases that involve leakages from the primary side of the Steam Generators to the secondary side.
- (3) There are four Steam Safety Relief Valves (also called Main Steam Safety Valves or MSSV) in each of the four Steam Mains, but only one per line is shown in the diagram. These are spring-loaded valves with auxiliary pneumatic operators. Their combined capacity is such that three out of the four MSSV's provide a flow of 115% of the steam flow from each steam generator. The valves have staggered set pressures, and will open between 5.11 MPa and 5.24 MPa.
- (4) There is an Atmospheric Steam Discharge Valve, in short ASDV, in each of the four Steam Mains. These valves have a total capacity of 10% of the unit's full power steam flow.

The ASDVs are normally closed, and are controlled by the Steam Generator Pressure Control program. They are opened when the Main Steam Header Pressure rises above the ASDV setpoint, which is typically 70 kPa above the Main Steam Header Setpoint. The valve opening is proportional to the pressure error. The ASDVs are also used to provide a heat sink for the reactor when the main condenser is unavailable.

The ASDVs open fully before the CSDVs begin to open. They are capable to go from closed to fully open in less than 2 seconds.

- (5) There are two Condenser Steam Discharge Valves, in short CSDVs connected from the Main Steam Header to the Condenser. Only one of these is shown on the diagram. These valves have a combined capacity of 100% of the unit's full power steam flow in case of a load rejection. The turbine bypass system is sized to permit a continuous steam flow to the condenser of up to 60% of full power steam flow.

The main function of these valves is to bypass the steam to the condenser when the turbine is not available, so that the reactor can continue to operate at up to 60%FP, in order to prevent a poison-out.

The CSDVs are normally closed, and are controlled by the Steam Generator Pressure Control program. They are opened when the Main Steam Header Pressure rises above the CSDV setpoint, which is typically 100 kPa above the Main Steam Header Setpoint. The CSDVs are capable to go from closed to fully open in less than 1 second.

7. STEAM GENERATOR AND MAIN STEAM SYSTEMS

- (1) Flow Measurement
- (2) Main Steam Isolation Valves
- (3) Steam Safety Relief Valves
- (4) Atmospheric Steam Discharge Valves
- (5) Condenser Steam Discharge Valves
- (6) Turbine Stop Valves
- (7) Isolation Valves

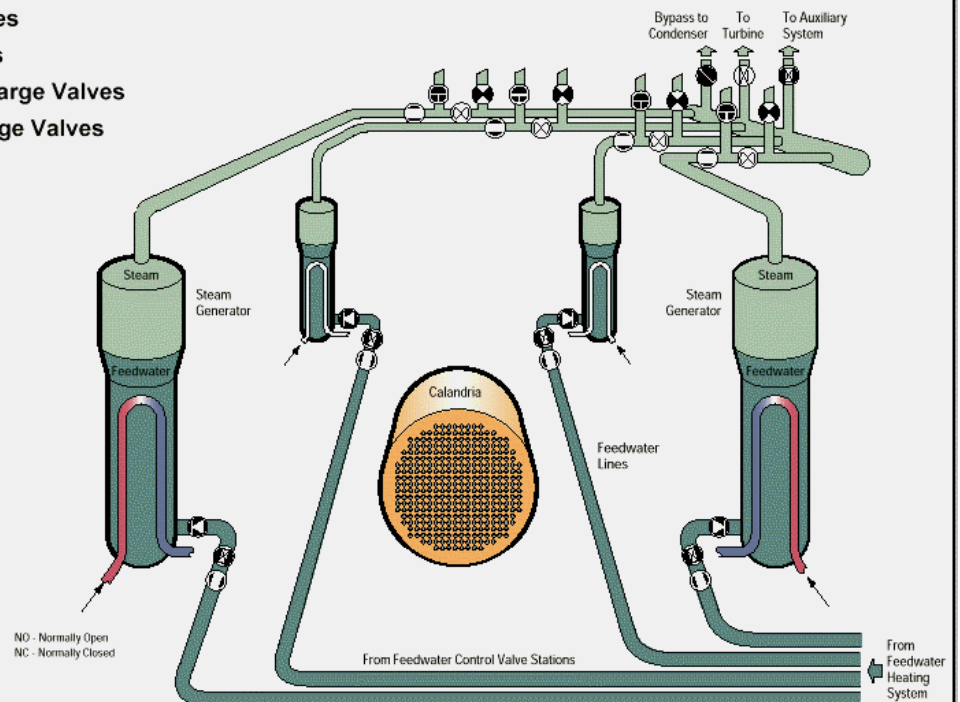

(6) There are Turbine Stop Valves (also called Main Stop Valves) upstream of the turbine control valves. These are hydraulically operated spring-closed valves that are normally open. Their main function is to close rapidly when required to protect the turbine against over-speed if the turbine control valves fail. Only one of these valves is shown on the diagram.

(7) There is an Isolation Valve in each of the steam lines to the various Auxiliary Systems. These are motorized valves that are normally open, and are closed either by automatic logic or remote-manually from the Main Control Room. They are provided for the purpose of being able to isolate each Auxiliary System from the Main Steam Header, typically in cases that involve leakages from the primary side of the Steam Generators to the secondary side.

8. FEEDWATER SYSTEM

The feedwater system supplies demineralized and preheated light water to the steam generators. The flow to each steam generator is via a set of valves, that include pneumatic control, motorized isolation, and check valves.

Varying the feedwater flow to each Steam Generator controls its level. The level setpoint is varied as a function of reactor power to ensure a consistent inventory of water in the steam generators, despite the expansion of the water with increased boiling.

The actual level measurement is combined with measurements of steam and feedwater flow, and the resultant control signal is used to adjust the feedwater control valve opening.

(1) Feedwater Flow Measurements are made in each of the four Feedwater Lines. These measurements are used for:

- (a) Input to the Reactor Regulating System for the computation of Reactor Thermal Power.
- (b) Input to the Steam Generator Level Control program to control the opening of the Feedwater valves.
- (c) Display by the Computerized Plant Display System and on the Control Room Panel Instruments.

(2) The Isolation Valves drawn in each of the Feedwater lines on the diagram are in fact a set of six valves, consisting of three parallel lines, each having a Control Valve and an Isolation Valve in series, as shown in the red line diagram.

The Isolation Valves are motor driven and are normally open. They are closed either by automatic logic or remote-manually from the Main Control Room. They are provided for the purpose of being able to isolate each Feedwater Flow Control Valve, typically in cases when the associated control valve needs to be removed from the flow path.

(3) There is a Check Valve, also called non-return valve, in the Feedwater line upstream of the flow entering each Steam Generator.

These valves are provided to prevent backflow in the unlikely event of feedwater pipe failure.

8. FEEDWATER SYSTEM

- (1) Flow Measurement
- (2) Isolation Valves
- (3) Check Valves

- Check Valve (NO)
- Steam Safety Relief Valve (NC)
- Main Steam Isolation Valves (NO)
- Atmospheric Steam Discharge Valves (NC)
- Condenser Steam Discharge Valves (NC)
- Turbine Stop Valves (NO)
- Isolation Valves (NO)
- Flow Measurement

NO - Normally Open
NC - Normally Closed

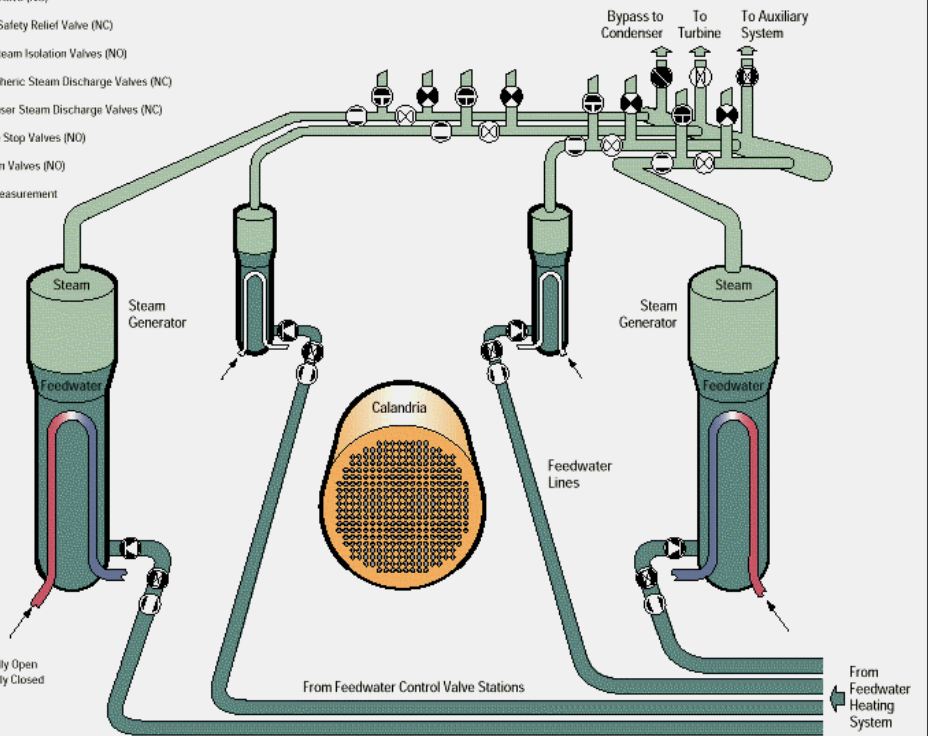

9. TURBINE, GENERATOR, CONDENSATE AND FEEDHEATING SYSTEMS

The diagram shows the main systems involved in converting the heat energy of the steam in the turbine to rotational energy, which in turn drives the generator to convert the mechanical energy to electrical energy.

In order to extract maximum energy from the steam, it needs to be condensed to a pressure and temperature that is as low as practicable. This takes place in the condenser, with the heat being removed to the environment by the condenser cooling water.

The feedheating system uses extraction steam from the turbine to raise the temperature of the feedwater before returning it to the steam generator. The flows, temperatures and pressures of the steam and feedheating systems are designed to optimize the thermodynamic efficiency of the steam cycle.

The following items highlight each of the main components in the turbine, generator and feedheating systems.

(1) The Main Steam Header collects the steam flow from the individual steam mains coming from each of the four steam generators, and distributes the steam to various loads.

Under normal operating conditions most of the flow is via the Governor Valves to the high pressure turbine. Smaller amounts go to the Steam Reheater, the high pressure heaters and some auxiliary loads.

If the Steam Generator Pressure rises above predetermined setpoints, usually because the turbine is unable to accept the full steam flow, steam release valves to the atmosphere and to the condenser open to discharge the excess steam, and to control steam pressure at its setpoint.

The diagram shows the Steam Mains, the steam flow to the Steam Reheater, the Governor Valve and the Condenser Steam Discharge Valves.

(2) The High Pressure Turbine is a double-flow unit, designed to work with saturated inlet steam. The amount of steam flowing to the high pressure turbine is controlled by the Governor Valves. Emergency Stop Valves in series with the Governor Valves are fully open under normal operating conditions, but will close rapidly in the event of a turbine trip.

(3) Separator and Reheater.

Steam exiting the high pressure turbine has about 10% moisture content, which must be removed prior to admitting the steam to the low pressure stages.

The Separator uses mechanical means to remove much of the moisture content, and in the Reheater live steam raises the steam to superheated conditions.

(4) The Low Pressure Turbine stage consists of three double flow low pressure cylinders. The steam from the Reheater passes through a set of intercept and release valves which, in the case of a turbine trip, will stop the flow of steam to the low pressure cylinders (intercept valves close) and bypass the steam to the condensers (release valves open).

Each of the three low pressure turbine cylinders is connected to a separate condenser shell where the exhaust steam is condensed.

(5) The Generator is a three-phase four-pole machine directly coupled to the turbine. In the case of electrical system operating at 60 Hz, the generator typically operates at 1800 rpm, and for 50 Hz systems at 1500 rpm. The output voltage is typically 24,000 volts, and is connected via forced air cooled, isolated phase bus duct to the step-up Main Output Transformer.

Cooling of the rotor winding and stator core is by hydrogen, and of the stator winding by water.

9. TURBINE, GENERATOR, CONDENSATE AND FEEDHEATING SYSTEMS

- (1) Main Steam Header
- (2) High Pressure Turbine
- (3) Separator & Reheater
- (4) Low Pressure Turbines
- (5) Generator
- (6) Condenser
- (7) Feedwater Heating

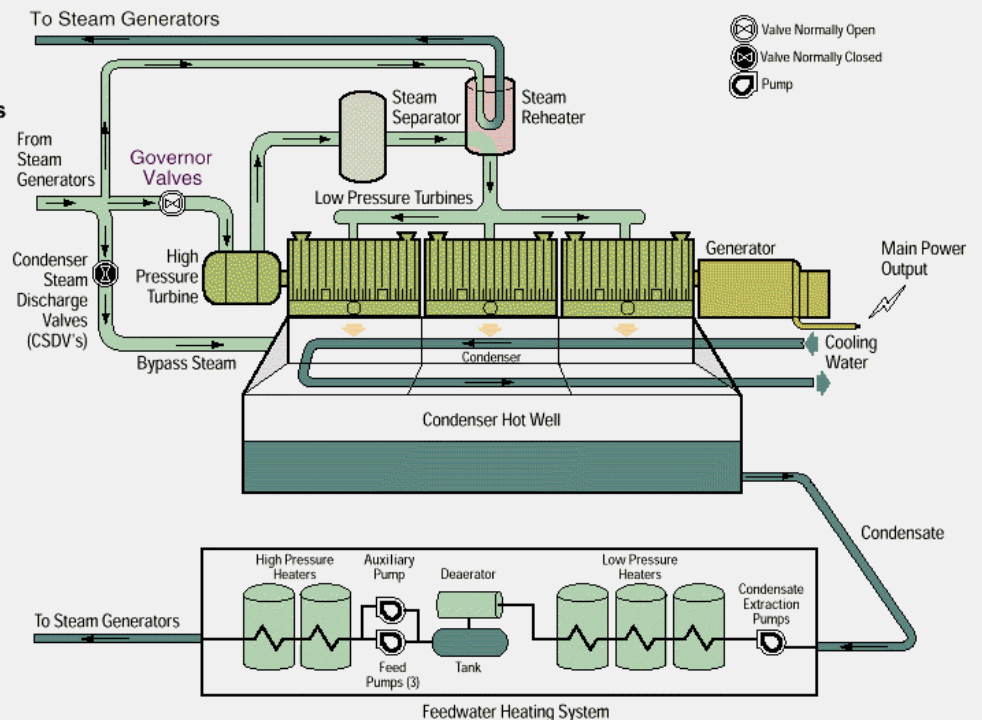

(6) The Condenser consists of three separate shells, one for each low pressure turbine cylinder. The exhaust steam from each turbine cylinder flows into the shells where it is condensed by flowing over tube bundle assemblies through which cooling water is pumped.

The condensed steam collects in the bottom of the condenser, in what is called the “hot well”. The condenser is capable of handling 100% steam flow for a few minutes, to allow reactor power to be reduced to 70% full power or lower, and at these levels the condenser can accept by-pass steam flow continuously.

(7) The Feedwater Heating System uses extraction steam to preheat the feedwater in order to optimize thermodynamic efficiency and to raise the temperature of the feedwater to the desired value for admission to the steam generators.

The main components of the Feedheating System are shown on the diagram. Starting from the Condenser Hot Well, the condensate is pumped through three low pressure heater units. In the Deaerator dissolved oxygen and other non-condensable gases are removed. The associated Storage tank acts as a reserve of feedwater, and by locating it high in the turbine building, it also provides the net positive suction head to the main feedwater pumps. Typically three large feed pumps and one auxiliary pump are used to return the feedwater to the steam generators.

Two high pressure heaters raise the temperature of the feedwater to a sufficient level to minimize thermal shock when entering the preheater section of the steam generator, where the feedwater temperature is raised to saturation value.

10. REACTOR SHUTDOWN SYSTEMS (SDS#1 and SDS#2)

In this and the next two sections we take a brief look at what are called the Special Safety Systems. These systems do not take any part in normal power plant operations, but are “poised” to act. In other words, they are waiting and watching in case the processes and their control systems cannot keep key operating parameters within prescribed limits. In such cases, when there is the potential for fuel failure to occur with a risk of radioactivity release, these special safety systems spring into action. If the control of reactor power is not assured, one or both Reactor Shutdown Systems will shut it down. If cooling of the fuel is judged to be insufficient, Emergency Core Cooling will be implemented; and if there is a risk, or perhaps an actual release of radioactivity from any of the plant systems, then the Containment System will ensure that no unsafe level of radiation is released to areas outside the plant’s boundary.

(1) There are two ‘full capability’ reactor shutdown systems in CANDU units. They are called Shutdown System Number 1, in short SDS1, and Shutdown System Number 2, or SDS2.

These two reactor shutdown systems are functionally and physically independent of each other, and each is able, on its own, to shut down the reactor and to keep it in the shutdown state.

As shown in the diagram, SDS1 uses solid neutron absorbing rods that are dropped into the core, while a liquid poison is injected into the moderator for SDS2. There is a very high level of functional independence provided by using two such fundamentally different methods of shutdown.

There is also a large measure of physical independence between systems as a result of the shutdown rods having been positioned vertically through the top of the reactor, while the poison injection tubes are located horizontally through the sides of the reactor.

The desired very high level of independence is further enhanced by using diversity between the two shutdown systems in every possible area, such as the types of instruments used, the choice of trip parameters, the type and source of control equipment hardware, the software languages used, and even the membership of the design and analysis teams.

(2) Shutdown System Number 1 is the primary method of quickly shutting down the reactor. SDS1 employs instruments that give parameter measurements and logic systems that process these measurements, that are different and independent from the corresponding components of SDS2 and the reactor regulating system. When the conditions for a reactor trip are detected by the SDS1 circuits, they send signals to de-energize the clutches that hold the neutron absorbing shutdown rods in their poised positions above the reactor core, allowing them to fall into the core.

The design philosophy of the trip systems is based on triplicating the measurement and processing of each signal, and initiating their protective action when any two of the three channels indicate that a trip condition exists based on any one variable, or a combination of different variables.

(3) Shutdown System Number 2 uses the rapid injection into the Moderator of a liquid that contains a strong neutron absorbing substance, for CANDU this is concentrated gadolinium nitrate. Such a liquid is called a “poison” because it rapidly shuts down the nuclear chain reaction.

The liquid poison is held in tanks outside the reactor, and the gas spaces above the liquid poison tanks are connected by a highly reliable set of quick opening valves to a tank containing helium under a high pressure. The triplicated parameter sensors and logic circuits of SDS2 are fully independent of the equipment and circuits of SDS1 and of the reactor control system, as I pointed out earlier. When the SDS2 logic system determines that there is a requirement for it to shut down the reactor, the fast-acting valves are opened, and the high pressure helium expels the liquid poison from the tanks into the horizontal tubes that are installed through the side of the calandria and through the injection nozzles into the moderator heavy water.

10. REACTOR SHUTDOWN SYSTEMS (SDS#1 and SDS#2)

- (1) There are two 'full capability' reactor shutdown systems, called Shutdown System Number One (SDS#1) and Shutdown System Number Two (SDS#2). They are functionally and physically independent of each other, and each able to shut down the reactor;
- (2) SDS#1 drops solid neutron absorbing rods into the core and these shutoff units are installed vertically through the top of the reactor.
- (3) SDS#2 injects liquid poison into the moderator and the poison injection tubes are installed horizontally through the sides of the reactor.
- (4) The two shutdown systems respond automatically to both neutronic and process signals
- (5) a very high level of independence is achieved by using diversity in:
 - (a) the types of instruments used,
 - (b) parameters measured
 - (c) the control equipment hardware
 - (d) software language
 - (e) design and analysis teams.

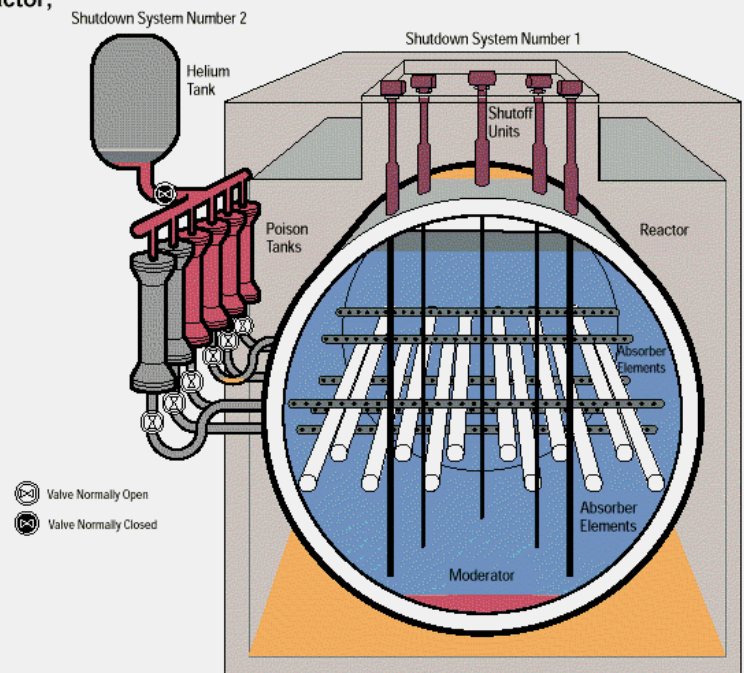

(4) Both SDS1 and SDS2 respond automatically to carefully chosen parameters, which include neutronic as well as process system signals. In addition to choosing as many different parameters to be measured as possible, if the same or similar trip parameter is used than the type of instrument, and its electrical supply will be different.

Typical variables that are used as trip parameters include the following:

- high neutron power
- high rate of log neutron power
- low heat transport coolant flow
- high heat transport pressure
- low pressurizer level
- low steam generator level
- high containment building pressure

(5) The desired very high level of independence between SDS1, SDS2 and the reactor regulating system is further enhanced by using diversity between these systems in every possible area, such as the types of instruments used, the source of electric and pneumatic power, the location and spatial orientation of wire runs, the choice of trip parameters, the type and source of control equipment hardware, the software languages used, and even the membership of the design and analysis teams.

11. NUCLEAR POWER PLANT SIMPLIFIED SCHEMATIC

This diagram shows a simplified schematic or block diagram of a typical nuclear power plant such as CANDU.

In order to help to explain how the control systems maintain the energy balance and do their control functions, I have broken down the diagram into five main groups of systems, namely the Nuclear Steam Supply Process Systems, the Steam Utilization Process Systems, the Nuclear Steam Supply Control Systems, the Steam Utilization Control Systems, and the Special Shutdown Systems.

By selecting each of these five topics we can build up the schematic diagram in a step-by-step fashion.

(1) Nuclear Steam Supply Process Systems

On this very much simplified diagram, I used only two blocks and the interconnecting circuit to represent the Nuclear Steam Supply Process Systems.

The Reactor block, the principle source of energy for the power plant, is indicated to include the nuclear fuel, the reactor coolant and the moderator.

The Steam Generator block is where the transfer of energy from the heavy water reactor coolant on the primary side to the light water on the secondary side of the steam generator takes place.

The Heat Transport system is shown only as the interconnection between the reactor and the steam generator blocks, with the pump symbol indicating the flow of coolant around the circuit, transferring heat from the reactor to the steam generator.

As we will see, from an overall unit control point of view, these three process systems of the Nuclear Steam Supply side of the plant are the ones of principle interest.

(2) For the Steam Utilization Process Systems I have chosen to highlight two groups of systems.

In the upper part of the diagram are the High and Low Pressure Turbines, with the Moisture Separator and Reheater between them, and the condenser at the outlet of the low pressure stage. The generator is connected to the same shaft as the turbine. As we will see, these are the systems principally involved with unit electrical output control and steam generator pressure control.

The lower part of the diagram shows the main blocks of the feedheating system, including the Condensate Extraction pumps, Low and High Pressure Heaters, the Deaerator and the Feedwater pumps. We will see how steam generator level control is accomplished in connection with the feedwater system.

(3) The two Nuclear Steam Supply Control Systems that we need to consider at this stage are the Reactor Regulating System and the Heat Transport Pressure and Inventory Control System.

The Reactor Regulating System has the task of keeping reactor power at the required level, and to maneuver it from one level to another at specified rates.

The Heat Transport Pressure Control System maintains the high pressure required to keep the coolant in the liquid state. During power operations, the pressure is constant, it only changes when the unit is not producing electric power and the reactor is in a shutdown state.

Because of thermal expansion, the volume of heavy water in the main circuit changes as a function of operating temperature, so control of the heavy water inventory is an integral part of the Heat Transport Pressure Control System.

(4) The two Steam Utilization Control Systems that we will deal with in this course are the Steam Generator Pressure Control System and the Steam Generator Level Control System.

The valves connected to the steam line from the steam generator to the turbine are involved in steam generator pressure control and protection. Under normal operating conditions the steam flow is from the steam generator through the Emergency Stop Valves that are fully open, and through the Governor Valves. The openings of the Governor Valves alter the amount of steam that flows to the turbine, and hence the power produced by the turbine. Changes in steam flow also affect the steam generator pressure.

11. NUCLEAR POWER PLANT SIMPLIFIED SCHEMATIC

- (1) Nuclear Steam Supply Process Systems
 (2) Steam Utilization Process Systems

- (3) Nuclear Steam Supply Control Systems
 (4) Steam Utilization Control Systems
 (5) Special Shutdown Systems

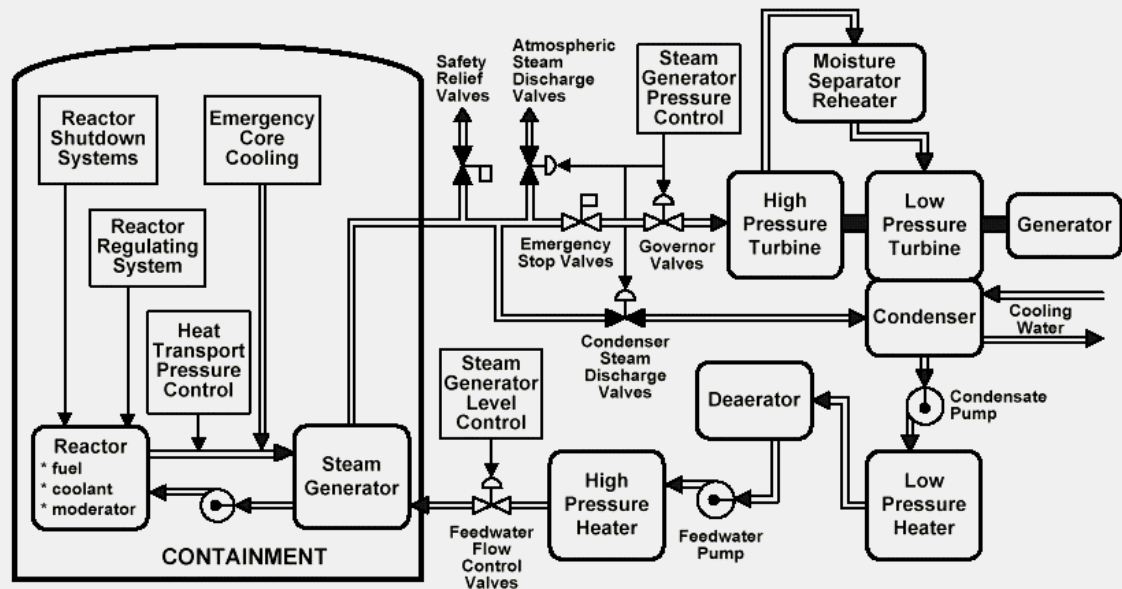

CANDU Overview

page 12/16

[Contents](#)

If the pressure rises above a specified margin, the Atmospheric Steam Discharge Valves open to limit the rise in steam pressure. If the pressure increases further, the Condenser Steam Discharge Valves open to bypass the turbine and discharge the steam directly to the condenser.

In case the Atmospheric and Condenser Steam Discharge Valves cannot maintain steam pressure below a specified value, the Safety Relief Valves open to ensure that the steam pressure does not exceed the safety limit.

Steam Generator Level Control is achieved by altering the openings of the Feedwater Flow Control Valves. By increasing the valves' openings, the flow of feedwater and hence steam generator level will increase, while the converse takes place if the valves' openings are decreased.

(5) Special Shutdown Systems.

All the systems that we have discussed so far have various safety devices and operating limits as integral parts of the design of each system. In nuclear power plants, there are additional safety features, and in particular special safety systems, that are designed to prevent the reactor's power level from going too high, ensuring that there is cooling of the fuel at all times, and that any radioactivity that may be inadvertently released from the fuel or any other station system, is contained within the reactor building structure.

In CANDU plants, there are two independent Reactor Shutdown Systems, each of which is fully capable to shut down the reactor and to keep it in the shutdown state.

The Emergency Core Cooling System has a high pressure injection part, an intermediate pressure injection component, and equipment for low pressure recovery operation.

The Containment system is designed to withstand the largest expected pressure increase, and to ensure that no unsafe amounts of radiation are released to the public under either normal or accident conditions.

12. CANDU NORMAL AND ALTERNATE MODES OF UNIT CONTROL

In this section we look at how the overall unit control modes are realized for CANDU power plants.

There are two basic alternatives, but one of these has two variants.

First we have "NORMAL" mode, in which the turbine leads the reactor.

The second case is "ALTERNATE" mode, in which the reactor leads the turbine, and the turbine is under Steam Generator Pressure Control.

We distinguish a third case, when the reactor is in "ALTERNATE" mode, but the turbine is Manually controlled. This mode is only used during certain stages of start-up and shutdown.

(1) In NORMAL mode, the unit operator specifies the target value of generator output setpoint and its rate of change.

The Unit Power Regulator uses the target values to change the generator power setpoint from its existing value to the new value. It also compares the setpoint with the actual generator output power, and in case of a difference sends a signal to the Turbine Controller, requesting a corrective action. The Turbine Controller will adjust the Governor valves to eliminate the error.

The Steam Generator Pressure Controller continuously monitors steam generator pressure. In response to a pressure error, it calculates a change in the reactor power setpoint, and sends the change request to the Reactor Regulating System.

The Reactor Regulating System computes a new setpoint based on the request from the Steam Generator Pressure Controller. It also compares the actual Reactor Power with the demanded power setpoint, and makes changes to the reactivity mechanisms so as to eliminate the reactor power error.

Changes in reactor power will result in changes in the heat generated in the reactor and through the actions of the heat transport system, to the amount of heat transferred to the steam generators. As the amounts of heat given up in the steam generators change, there will be corresponding changes in steam generator pressure.

If the steam pressure rises above a predetermined level, the Steam Generator Pressure Controller will open the ASDVs, and if there is a further increase in pressure, the CSDVs also.

(2) In ALTERNATE mode, the unit operator specifies the target value of reactor power setpoint and its rate of change.

The Reactor Regulating System uses the target values to change the reactor power setpoint from its existing value to the new value. It also compares the setpoint with the actual reactor power, and makes changes to the reactivity mechanisms so as to eliminate the reactor power error.

Changes in reactor power will result in changes in the heat generated in the reactor and through the actions of the heat transport system, to the amount of heat transferred to the steam generators. As the amounts of heat given up in the steam generators change, there will be corresponding changes in steam generator pressure.

The Steam Generator Pressure Controller continuously monitors steam generator pressure, and compares it with the setpoint, which is constant, except under certain startup and shutdown conditions. In case of a pressure error, it sends a signal to the Turbine Controller, requesting a corrective action. The Turbine Controller will adjust the Governor valves to eliminate the error.

If the steam pressure rises above a predetermined level, the Steam Generator Pressure Controller will open the ASDVs, and if there is a further increase in pressure, the CSDVs also.

12. NORMAL AND ALTERNATE MODES OF UNIT CONTROL

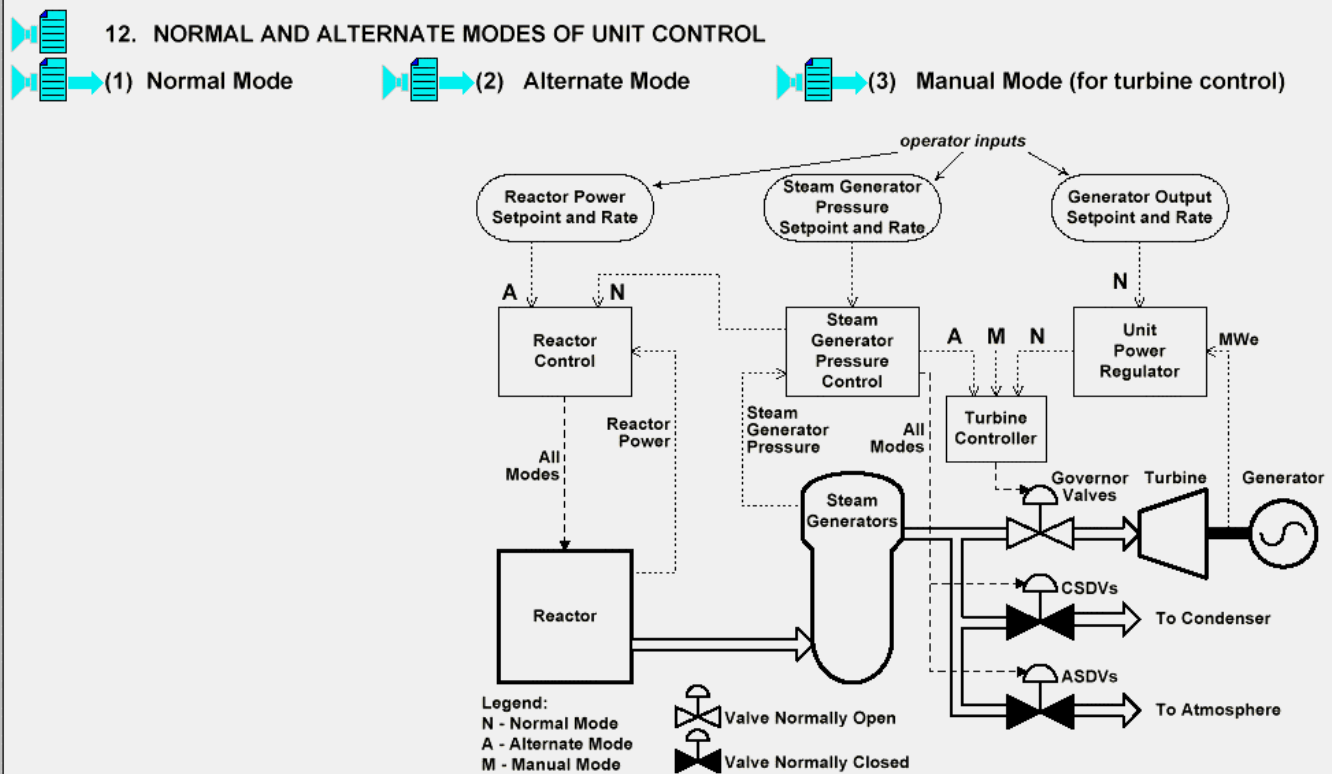

(3) The Turbine Controller may be disconnected from the steam generator and placed under MANUAL control under certain startup and shutdown conditions. The reactor will be in ALTERNATE mode in such a case, as described in item (2).

The Steam Generator Pressure Controller has no effect on the Governor valves in this mode of operation. The only control action it has is to open the steam discharge valves in case the steam pressure rises above the setpoints for the ASDVs and CSDVs.

13. SIMPLIFIED BLOCK DIAGRAM OF THE MAIN PROCESS AND CONTROL SYSTEMS

In Section 8 we extend what we have learned in the previous four sections about overall unit control. We will look at how the systems involved in overall unit control interact with the main process systems under normal operating conditions. We also will take a brief look at two other control systems that are not directly involved in Overall Unit Control, but which do have important control actions in maintaining heat transport pressure and inventory, and steam generator level at the correct values. I will use this simplified block diagram to illustrate each of six important areas of CANDU process and control systems.

(1) The first set of blocks I would like to consider are the Reactor, the Moderator and the Reactor Regulating System. The main interactions are shown on the diagram, and they include:

- fresh fuel being added to the reactor and spent fuel being removed,
- the flow of heat transport heavy water that removes the heat generated by the reactor,
- the flow of moderator heavy water to and from the reactor, removing the heat generated in the calandria heavy water and other structures,
- the Reactor Regulating System, which measures the power level in the reactor, compares it with the operator specified setpoint, and makes adjustments to the reactivity mechanisms to eliminate any error between the actual and demanded reactor power levels.

(2) The second set of blocks includes the Main Heat Transport System and the Heat Transport Pressure and Inventory Control System. The main interactions are shown on the diagram, and they include:

- the flow of heat transport heavy water that removes the heat generated by the reactor and transfers it to the Steam Generators,
- the Heat Transport Pressure and Inventory Control System, which is responsible for maintaining a pressure of 10 - 11 Mega Pascals in the main circuit. The pressure in the main circuit is kept at a constant value, irrespective of power level, but because the volume of heavy water in the main circuit varies as a function of the operating temperature, the inventory control system adds or removes liquid as needed from the main circuit.

(3) The third set of blocks includes the Steam Generator and Main Steam System, the Feedwater System, and the Steam Generator Pressure and Level Control Systems. The main interactions are shown on the diagram, and they include:

- the flow of heat transport heavy water that transfers the heat generated by the reactor to the Steam Generators;
- the flow of steam from the Steam Generators to the Turbine;
- the flow of condensed steam from the Turbine via the Condenser and the Feedwater System back to the Steam Generators;
- the Steam Generator Pressure Control System, which is responsible for maintaining a pressure in the order of 4.7 Mega Pascals in the steam generators. The pressure is kept at a constant value irrespective of power level. In NORMAL mode, the pressure control system alters the reactor power setpoint to eliminate any pressure error. In ALTERNATE mode the position of the governor valves is altered to keep steam generator pressure constant;
- the Steam Generator Level Control System adjusts the Feedwater flow in response to changes of inventory of light water in the steam generators: volumetric changes due to temperature differences, variations in steam or feedwater flow, and level fluctuations are all taken into account by the Steam Generator Level Control System.

(4) The fourth set of blocks includes the Turbine and Generator, the Turbine Controller and the Unit Power Regulator Systems. The main interactions are shown on the diagram, and they include:

- the flow of steam from the Steam Generators to the Turbine;
- the flow of condensed steam from the Turbine via the Condenser to the Feedwater System;
- the output of electrical energy from the Generator to the Electric Power System;
- the monitoring of Turbine and Generator parameters by the Turbine Control System, and the sending of control signals from the Turbine Controller to the Governor Valves, Emergency Stop Valves, Atmospheric and Condenser Steam Discharge Valves;
- the Unit Power Regulator System, which receives the demanded generator power level from the operator, compares it with the actual generator output, and subject to the status of the Turbine parameters, instructs the Turbine Controller to make the necessary adjustment in valve openings to match the actual and demanded generator power levels.

13. SIMPLIFIED BLOCK DIAGRAM OF THE MAIN PROCESS AND CONTROL SYSTEMS

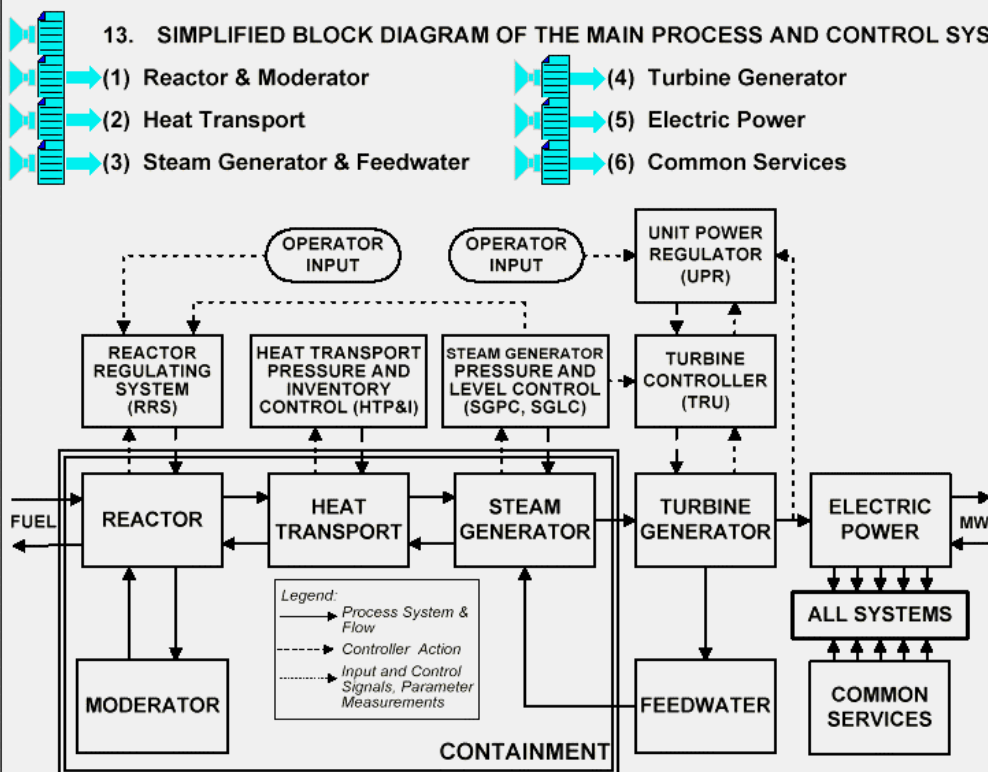

(5) The fifth topic to be considered on the block diagram is the Electric Power System. It includes the Electric Output System and Plant Electrical Distribution System. The main interactions are shown on the diagram, and they include:

- the flow of electrical energy from the Generator to the Bulk Electric Power System, which is often simply called the Grid;
- the output of the generated electrical energy, after transformation, to the Grid;
- the flow of electrical energy from the Grid, after transformation, to the plant systems;
- and it is important to note, that as shown on the diagram, all the plant systems receive electrical energy at various voltages from the Plant Electrical Distribution System.

(6) The sixth topic to be considered on the block diagram is called Common Services. It includes all the water and pneumatic systems, communication systems, chemical and waste handling, transportation of materials and equipment, and many others. These are far too numerous to cover in this course, but as indicated in the diagram, Common Services, in one form or another, interact with all the systems that constitute an operating nuclear generating station.

14. COMPUTERIZED PLANT CONTROL SYSTEMS

So far in this Session we have looked at various aspects of overall unit control. In this section I have summarized some key aspects of the five main CANDU process control systems. As noted earlier, the control algorithms for each of these systems is implemented in the form of software, executed on both of a unit's Digital Control Computers. In the table I have listed for each program the parameters being measured, the variables that are controlled, and the variables that are manipulated by the control system.

- (1) The Unit Power Regulator or in short form UPR program has as input the measurement of electrical output from the unit, which is compared with the setpoint for unit power output. The variable that is controlled is the electrical output of the generator, and this is accomplished by varying the steam flow into the turbine by altering the opening of the governor valves.
- (2) The Reactor Regulating System or in short form RRS program has as inputs various measurements of reactor neutron power, both for the reactor as a whole and its spatial distribution, as well as measurements that indicate the thermal power being produced by the reactor. The total reactor neutron power is compared with the reactor power setpoint to compute the reactor power error. The variable controlled is the neutron flux, by altering the positions of the various reactivity mechanisms, such as the insertion or removal of control rods, and the level of water in the liquid zone controllers.
- (3) The Heat Transport Pressure and Inventory Control System or is short form HTP&I program has as input Reactor Outlet Header (ROH) Pressure. This pressure is controlled relative to the pressure setpoint that is constant during normal power operations. ROH Pressure is controlled via the pressure of the Pressurizer, and the inventory of heavy water in the Main Heat Transport circuit is controlled via the level of the Pressurizer. The variables manipulated are the Pressurizer steam bleed valves and the heaters, to control Pressurizer pressure, and the feed and bleed of heavy water to and from the main circuit are used to control Pressurizer level.
- (4) The Steam Generator Pressure Control System or is short form SGPC program has as inputs Steam Generator Pressure and Reactor Power. This pressure is controlled relative to the pressure setpoint that is constant during normal power operations. Steam Generator Pressure is controlled in NORMAL mode by altering the Reactor Power setpoint, and in ALTERNATE mode by altering the steam flow through the Governor valves. In case of high pressure, SGPC will open steam discharge valves to the atmosphere and to the condenser.
- (5) The Steam Generator Level Control System or is short form SGLC program has as inputs Steam Generator Level, Reactor Power, Steam flow and Feedwater flow. The variable controlled is level, but in a manner that ensures that the inventory of light water in the steam generators is constant at all power levels. Steam Generator Level is controlled by altering the feedwater flow, by changing the opening of the feedwater control valves.

14. COMPUTERIZED PLANT CONTROL SYSTEMS

Because of the complex interdependence of control systems in a CANDU unit, Digital Control Computers (DCC) perform all major control functions. The five main programs with the parameters measured and the different variables controlled and manipulated, are summarized in Table 1.

Table 1: Main CANDU Control Programs.

Program Name	Measured Parameter (s)	Variable(s) Controlled	Variable(s) Manipulated
1. Unit Power Regulator (UPR)	<ul style="list-style-type: none"> Electrical output 	<ul style="list-style-type: none"> Electrical output 	<ul style="list-style-type: none"> Steam flow
2. Reactor Regulating System (RRS)	<ul style="list-style-type: none"> Reactor neutron power Reactor thermal power 	<ul style="list-style-type: none"> Neutron flux 	<ul style="list-style-type: none"> reactivity mechanisms <ul style="list-style-type: none"> - control rod position - zone water level
3. Heat Transport Pressure and Inventory Control (HTP&I)	<ul style="list-style-type: none"> Reactor Outlet Header pressure 	<ul style="list-style-type: none"> Pressurizer pressure Pressurizer level 	<ul style="list-style-type: none"> Pressurizer steam bleed & heaters D₂O feed & bleed
4. Steam Generator Pressure Control (SGPC)	<ul style="list-style-type: none"> Steam Generator pressure Reactor power 	<ul style="list-style-type: none"> Steam Generator pressure 	<ul style="list-style-type: none"> Reactor setpoint Steam flow
5. Steam Generator Level Control (BLC)	<ul style="list-style-type: none"> Steam Generator level Reactor power Feedwater flow Steam flow 	<ul style="list-style-type: none"> Steam Generator Level (inventory) 	<ul style="list-style-type: none"> Feedwater flow

15. CANDU 9 OPERATING CHARACTERISTICS

The diagram shows the changes in the main unit parameters as reactor power and generator output are reduced from the normal operating value of 100% full power to zero output. The parameter changes illustrated are essentially the same whether the unit is operating in "NORMAL" or "ALTERNATE" mode, only the magnitude, direction and relative timing of the short term parameter transients would differ.

In "NORMAL MODE" generator power decreases in response to the power level reduction request input via the UPR program, and reactor power follows the decrease. In "ALTERNATE MODE" reactor power decreases in response to the power level reduction request input via the RRS program, and generator power follows.

The other plant parameters are held either constant by their respective control systems, or change in response to programmed setpoint changes, or as consequence of the reduced operating power level.

Heat Transport Pressure is kept constant at 10 MPa by the HT pressure control system.

Heat Transport Flow is kept constant by the main circulating pump flow characteristics.

The Heat Transport Coolant Temperature change across the reactor slightly increases when power is reduced below 100%FP because reactor inlet temperature drops as power is reduced while the reactor outlet temperature remains essentially constant while there is boiling near the outlet of most channels. Once the outlet channel temperatures fall below the saturation temperature, the coolant temperature change across the reactor also falls as a function of decreasing reactor power.

Pressurizer Level decreases in response to the programmed level setpoint decrease of the HT Inventory Control program.

Steam Generator Pressure is kept constant by the Steam Generator Pressure Control program.

Steam Generator Level decreases in response to the programmed level setpoint decrease of the Steam Generator Level Control program.

Steam Flow decreases due to the Governor Valve opening being reduced by the Steam Generator Pressure Control program.

Feedwater flow decreases due to the decrease in Steam Flow.



15. CANDU 9 OPERATING CHARACTERISTICS

Reactor Power	100 to 0%FP	
HT Pressure	Constant at 10 MPa (programmed SP)	
HT Coolant Flow	Constant (~2,670 kg/sec/loop)	
HT Coolant Temperature change across the Reactor	Decrease	
Pressurizer Level	Decrease (programmed SP)	
Steam Generator Pressure	Constant at 4.7 MPa (programmed SP)	
Steam Generator Level	Decrease (programmed SP)	
Steam Flow	Decrease	
Feedwater Flow	Decrease	
Generator Output	100 to 0%FP	

SESSION 2:

MODULE CONTENTS

1.	INTRODUCTION	page 2
2.	CANDU REACTOR ASSEMBLY	page 3
3.	FUEL BUNDLE	page 6
4.	REACTIVITY CONTROL DEVICES	page 7
5.	REACTOR REGULATING SYSTEM	page 14
6.	SIMPLIFIED RRS BLOCK DIAGRAM	page 19
7.	REACTIVITY DEVICE CONTROL	page 25
8.	REACTOR CONTROL	page 29

2. CANDU REACTOR ASSEMBLY – FUNCTIONAL REQUIREMENTS

The diagram illustrates many of the essential features of the CANDU reactor:

- the large horizontal cylinder shaped Calandria that contains the low pressure Moderator;
- the Pressure Tubes that traverse the Calandria from one end to the other and hold the fuel and the high pressure heavy water coolant, and allow for on-line refuelling;
- the Reactivity Control mechanisms, Shutdown Rods and associated vertical in-core flux measuring devices that penetrate the Calandria from the top;
- the Ion Chambers, horizontal in-core flux measuring devices and the second reactor shutdown system's liquid poison injection nozzle assemblies that penetrate the Calandria from the side;
- the end shields and the concrete walls of the vault that provide both structural support and radiation shielding.

(1) The calandria is the main structural component to hold the fuel channels and to contain the moderator such that a controlled nuclear fission chain reaction will occur to produce heat. The Calandria shell is closed and supported by the End Shields at each end. The fuel channels are supported principally by the End Shields. The Calandria and the End Shields are themselves supported by the walls of the Reactor Vault.

(2) The heat generated in the fuel by nuclear fission is removed by the pressurized heavy water coolant that flows around and through the fuel bundles. Each fuel channel holds 12 fuel bundles. At either end, each pressure tube is connected by a feeder pipe to the respective header of the main heat transport system. The flow of coolant in adjacent fuel channels is in opposite directions, i.e. the flow through the core is bi-directional. The CANDU 6 reactor has 380 fuel channels, the CANDU 9 reactor has 480.

(3) At both ends of the fuel channels the zirconium pressure tubes are connected to stainless steel end fittings, which provide mechanical connections for the fuelling machines. The on-line refuelling system uses two identical fuelling machines, which are attached to the ends of the channel to be refuelled. One machine inserts new fuel at one end of the channel and the second machine removes irradiated fuel at the other end. The complete refuelling operation of a channel is achieved by remote control while the reactor is operating.

(4) The Calandria vessel is made of stainless steel and is usually fabricated at a significant distance from the power plant site. Its design has to accommodate the specified range of temperatures, pressures, radiation fields and loads acting on it during fabrication, transportation, storage, installation, normal and abnormal operation, and all design basis events including earthquakes. Installation of the various equipment, such as the pressure tubes, reactivity mechanisms and flux detectors takes place at the power plant site. The concrete vault that houses the calandria and all related reactor components are built during the construction of the plant, and must also withstand a design basis earthquake.

(5) The vertical and horizontal reactivity control devices, both for reactor regulation and shutdown, and the neutron flux detector assemblies are positioned in the Calandria. They are inside guide tubes that pass through the thimbles and in between the calandria tubes, and are attached at the bottom of the Calandria.

2. CANDU REACTOR ASSEMBLY - FUNCTIONAL REQUIREMENTS

- ▶ (1) to support and locate the fuel channels and contain the moderator such that a controlled nuclear fission chain reaction will occur to produce heat;
- ▶ (2) to provide for the removal of the heat generated by nuclear fission;
- ▶ (3) to provide for the fuel to be replaced while the reactor is operating;
- ▶ (4) to accommodate the specified temperatures, pressures, radiation fields and loads acting on the reactor during normal and abnormal operation, fabrication, transportation, storage, installation, and all design basis events including a design basis earthquake;
- ▶ (5) to locate and support the specified reactivity measurement, control and shutdown devices;
- ▶ (6) to provide radiation and thermal shielding to protect nearby equipment and permit access for maintenance;
- ▶ (7) to provide for major components, except the calandria-shield tank assembly, to be easily replaced or refurbished, which may be required after more than 30 years, to obtain a plant design life of 60 years.

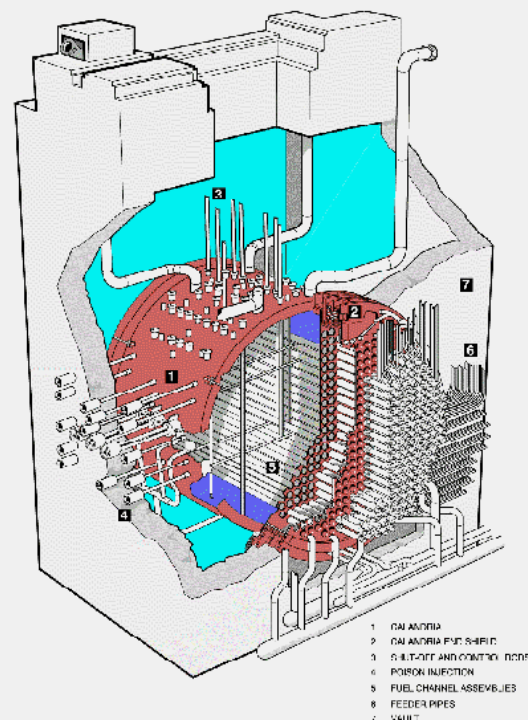

(6) In the axial direction of the Core, radiation and thermal shielding is provided by the End Shields. Each End Shield consists of an inner and outer tubesheet, which are joined by lattice tubes and a peripheral shell. The space inside the End Shield is filled with steel balls and ordinary water. The water is circulated through a cooling system to remove the absorbed heat.

In the radial direction, light water is used to provide shielding, in addition to the vault walls. For CANDU 6 the vault itself is filled with water. For CANDU 9 a Shield Tank, which surrounds the Calandria and is connected to the End Shields contains the light water for both thermal and biological shielding.

The shielding is designed to allow personnel access to the reactor face once the reactor has been shut down.

(7) The reactor assemblies are designed to allow all the major components to be easily replaced or refurbished during the extended (up to 60 years) operating life of the reactor. Such components include all the reactor control and shutdown mechanisms, the flux detectors, the pressure tubes, the feeder pipes, but not the calandria-shield tank assembly.

2.1 CANDU 9 REACTOR ASSEMBLY

This diagram shows additional details of the reactor assembly as compared with the figure on the previous page. Also note that this diagram illustrates a CANDU 9 reactor assembly: it has a shield tank, and the vault contains air, while the CANDU 6 Reactor Assembly shown on the previous page did not have a shield tank, but instead had the reactor vault filled with water.

- (1) The arrows point to the six walls that form the vault: above and below, behind, in front of and on both sides of the reactor. The approximate dimensions of the CANDU 9 reactor vault are: 20 m high, 20 m wide and 12.5 m deep
- (2) The reactivity mechanism deck holds all the flux measuring and controlling devices that penetrate the Calandria from above the reactor. The in-core vertical flux detectors measure the flux distribution in the core for both control and protection purposes. The vertical reactivity control devices include the different types of reactor control rods and the reactor shutdown rods.
- (3) There are horizontal flux measuring devices and reactivity control units that penetrate the Calandria from the side. Arrow (a) points to one of the liquid poison injection nozzle assemblies of the second reactor shutdown system, which are used for the rapid shutdown of the reactor by the injection of liquid poison into the moderator. Arrow (b) points to one of the Ion Chamber assemblies, each of which measures the flux for the purpose of both regulation and protection. Arrow (c) indicates one of the horizontal in-core flux detector assemblies, used to provide flux measurement for the second shutdown system.
- (4) The Shield Tank has a diameter of 13.3 m, and in combination with the End Shields, a length of 8.1 m. The Shield Tank and End Shields completely surround the Calandria, as shown by arrow (a). The space between the Shield Tank shell and the Calandria is filled with ordinary light water. The two End Shields are filled with steel balls and light water, as indicated by arrows (b) and (c). Such shielding allows maintainers to work in the reactor vault and in the fuelling machine vault when the reactor is in the shutdown state. The water in the End Shields is cooled to remove the heat transferred from the heat transport system and generated by neutron absorption.

Arrow (d) points out the three main components that form the structure of the End Shields: the Calandria Side Tubesheet, the Lattice Tubes, and the Fuelling Machine Side Tubesheet.

Arrow (e) indicates the position of one of the Shield Tank over-pressure rupture disc and piping assemblies.
- (5) The Calandria contains the Moderator heavy water, and also forms the inner shell of the Shield Tank. It has a diameter of 8.5 m and is 6 m long.
- (6) The Reactor Core is regarded as the volume that contains the fuel, which in the case of CANDU corresponds essentially to the volume defined by the pressure tubes inside the Calandria. This volume is approximately 7 m in diameter and 6 m in length. Note that the diameter of the core is 1.5 m less than that of the Calandria, the volume of heavy water between the core and the Calandria wall acts as a reflector of thermal neutrons.

▶ 2.1 CANDU 9 REACTOR ASSEMBLY

Note that the CANDU 6 Reactor Assembly shown on the previous page did not have a shield tank, but had the reactor vault filled with water to act as a radiation shield and back-up cooling.

The CANDU 9 Assembly shown on this diagram has a shield tank, and the vault contains air.

- ▶ (1) reactor vault is approximately 20 m high, 20 m wide and 12.5 m deep;
- ▶ (2) the reactivity mechanism deck holds all the vertical flux measuring devices, vertical reactor control and safety devices;
- ▶ (3) the horizontal reactivity control units (liquid poison injection) and flux measuring devices;
- ▶ (4) the shield tank and end shields are filled with steel balls and light water: 13.3 m diameter and 8.1 m long;
- ▶ (5) the calandria is 8.5 m diameter and 6 m long;
- ▶ (6) the reactor core is 7 m diameter and 6 m long.

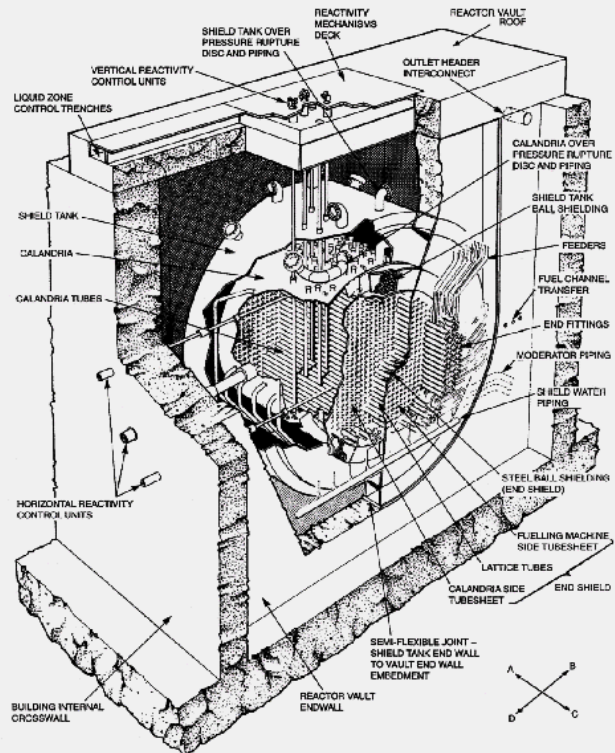

2.2 CALANDRIA AND FUEL CHANNEL ASSEMBLIES

This diagram shows a cross section of the Calandria, End Shield and Fuel Channel assemblies. Many of the components shown on the previous page can be seen more clearly on this figure. The inset shows additional details of a Pressure Tube containing the fuel bundles.

- (1) The Calandria Shell and the two End Shields form the Calandria vessel. Note that the diameter of the Calandria shell is stepped down to the smaller diameter of the End Shields, this is done to allow for thermal flexing of the Calandria shell and also to optimize the volume of heavy water for the purpose of neutron reflection.

Each of the two End Shields consists of an inner (or calandria side) and an outer (or fuelling machine side) tubesheet, which are joined by lattice tubes and a peripheral shell to form a closed vessel that is filled with carbon steel balls and shield cooling water.

- (2) There is an End Fitting, at arrows (a) at each end of every fuel channel. The End Fitting has a number of purposes, as indicated on the diagram. One of these is to provide the connection between the Pressure Tube and the Reactor Inlet or Outlet Header of the Heat Transport System. This is done via the Feeder Pipe as indicated by Arrow (b).

A second function is to allow on-power refuelling, whereby the fuelling machine removes the Channel Closure Plug, shown at arrow (c).

There is a Liner Tube, at arrow (d), that extends through the End Fitting to assist the movement of fuel bundles and the flow of coolant in and out of the Pressure Tube.

A Shield Plug, at arrow (e), is located inside the Liner Tube of the End Fitting, to provide radiation shielding where the End Fitting passes through the Reactor End Shield. It also holds the fuel bundles in the core against the flow of coolant.

A Positioning Assembly, at arrow (f) is attached to each End Fitting to hold the entire fuel channel assembly in place. One end is locked in place while the other allows for pressure tube elongation that takes place under the normal operating conditions of neutron flux and coolant temperature.

- (3) The portion of the Fuel Channel that is within the Calandria consists of the Pressure Tube and the Calandria Tube. The Pressure Tubes hold the fuel in the reactor core and allow the pressurized Heat Transport coolant to flow through them and to remove the heat generated in the fuel. As indicated on both the main diagram and the inset, the Pressure Tube is surrounded by the Calandria Tube, and the annular space between them is maintained by spacers and is filled with a gas.

▶ 2.2 CALANDRIA AND FUEL CHANNEL ASSEMBLIES

The main components of the Calandria, End Shield and Fuel Channel assemblies are shown on this diagram, including details of a Pressure Tube containing the fuel bundles.

- ▶ (1) Calandria and End Shield
- ▶ (2) End Fitting and Positioning Assembly
- ▶ (3) Pressure and Calandria Tube

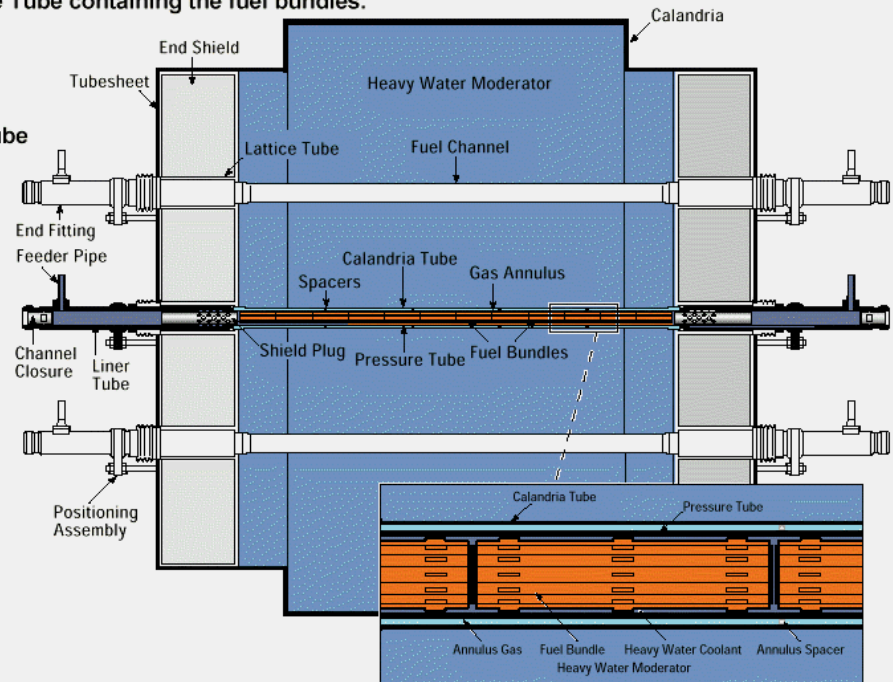

3. MAIN FEATURES OF THE FUEL BUNDLE:

Please point your mouse to the words FUEL BUNDLE in blue letters to see a photograph of fuel bundles being inspected. Since each bundle weighs about 25 kilograms they can be easily handled by one person. The use of natural uranium eliminates the possibility of the fuel going critical in either air or light water.

- (1) CANDU 6 and CANDU 9 reactors use fuel bundles made up of 37 fuel pencils or elements. Each fuel pencil consists of a Sheath and End Cap that form the so called fuel cladding, made of Zircalloy-4 and enclosing the UO_2 fuel pellets. The Fuel Bundle holds together the 37 fuel elements by two End Plates. The elements are spaced from each other by the End Plates and by Inter Element Spacers at the middle of the bundle. Bearing Pads on the outer pencils support the bundle in the fuel channel.
- (2) All the structural components, such as the Fuel Sheath, the End Caps, the End Plates, the Inter Element Spacers and the Bearing Pads are made from Zircalloy-4, because it has the desired characteristics of low neutron absorption, low hydrogen pickup and good corrosion resistance.
- (3) The fuel is made of natural uranium dioxide with 0.71% $\text{U}235$ content, and is formed into high density pellets. There are typically 30 fuel pellets in a fuel pencil. A thin graphite layer, called Canlub is applied on the inner surface of the fuel sheath to reduce the effects of interactions between the pellets and the cladding that would result from changes in reactor power level.
- (4) Other than the End Plates and the Inter Element Spacers, no other structural components are required for a fuel bundle, since they are supported by the Pressure Tube and held in place by the Shield Plugs. Because the fuel elements are in a horizontal position, gravitational pellet relocation cannot take place. A fully loaded fuel bundle weighs about 25 kilograms, of which more than 90% is uranium oxide fuel.

3. MAIN FEATURES OF THE FUEL BUNDLE:

- ▶ (1) CANDU 6 and CANDU 9 reactors use the 37-element fuel bundle design;
- ▶ (2) the fuel sheath is made from Zircaloy-4:
 - low neutron absorption,
 - good corrosion resistance,
 - low hydrogen pickup;
- ▶ (3) the fuel pellets are made from uranium dioxide with 0.71% U235;
- ▶ (4) a fully loaded fuel bundle weighs about 24 kg, of which more than 90% is uranium oxide fuel; bundle length is 495.3 mm, outside diameter is 102.4 mm.

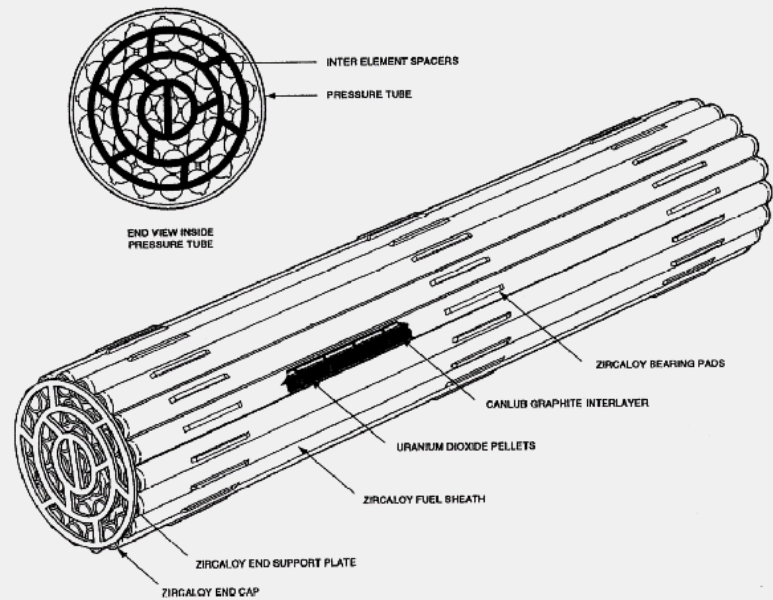

4. REACTIVITY CONTROL DEVICES

The next few displays present the devices used to control the reactivity of a CANDU core. These devices or mechanisms are used for both regulation (i.e. control) and protection (i.e. safety).

As explained in Session 1, all the devices used for reactor regulation are inserted from the top of the reactor, as are the safety system devices for Reactor Shutdown System #1, while for Shutdown System #2, horizontally mounted poison injection nozzle assemblies are used.

The reactor regulating system of CANDU reactors control both the total neutron flux as well as its spatial distribution. Control of the flux shape is important for the following reasons:

- the physical dimensions of the core of a CANDU 6 or 9 reactor are large in relation to the average distance traveled by a neutron, hence local neutron flux disturbances could develop while bulk power is held constant;
- an even flux distribution is necessary to achieve maximum extraction of energy (“burn-up”) from each fuel bundle;
- preventing local flux peaks is essential to minimizing damage to the fuel.



4. REACTIVITY CONTROL DEVICES

The next few displays present the devices used to control the reactivity of a CANDU core. These devices or mechanisms are used for both regulation (i.e. control) and protection (i.e. safety).

As explained in Session 1, all the devices used for reactor regulation are inserted from the top of the reactor, as are the safety system devices for Reactor Shutdown System #1, while for Shutdown System #2 horizontally mounted poison injection nozzle assemblies are used.

The reactor regulating system of CANDU reactors control both the total neutron flux as well as its spatial distribution. Control of the flux shape is important for the following reasons:

- the physical dimensions of the core of a CANDU 6 or 9 reactor are large in relation to the average distance traveled by a neutron, hence local neutron flux disturbances could develop while bulk power is held constant;
- an even flux distribution is necessary to achieve maximum extraction of energy ("burn-up") from each fuel bundle;
- preventing local flux peaks is essential to minimizing damage to the fuel.

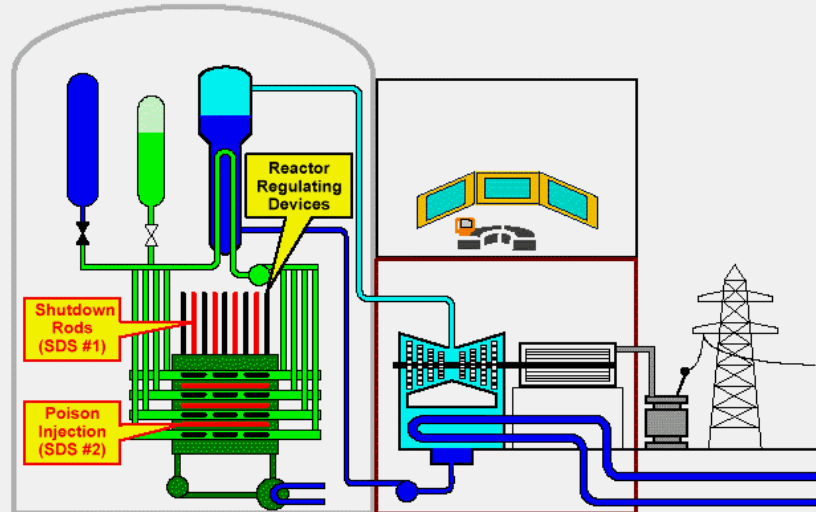

4.1 LIQUID ZONES

In order to control the spatial flux distribution in the reactor, the core is divided into 14 regions or zones. These zones can be thought of as lightly coupled regions of the core, which means that there is a high probability that a neutron born in the centre of one of these zones will cause fission in the same zone.

In order to control the flux in each zone, two requirements must be met: first the flux has to be measured in each zone, and second, there must be a means of controlling the reactivity in each zone, independently of every other zone.

(1). Heavy water moderated reactors such as CANDU rely on a very high level of purity (better than 99%) of D₂O. Even a small amount of H₂O present in the moderator or the heat transport coolant will absorb a significant number of neutrons, and causing a reduction in fuel conversion efficiency. The fact that light water acts as a strong neutron absorber in a heavy water moderated reactor can be used to devise an effective reactivity control mechanism. Control rods made of neutron absorbing material will distort the flux throughout their range of travel. However, having a light water compartment in a given location of the core, by varying the level of the water in these compartments, the local flux can be altered, without affecting the flux in other parts of the core.

Such a system of compartments containing variable amounts of light water distributed in a CANDU reactor core is called the “liquid zone control system”. On the diagram five of the 14 zones are shown enlarged, with the arrows indicating that the level of water in each compartment is variable. As we will see, the level change is achieved by altering the flow differential in and out of each compartment. The small amounts of water flow do not disturb the flux, relative to the effects of the volumes that accumulate in each zone compartment.

(2) The 14 zones are distributed as two axial halves, each half having seven zones. In the illustration the “front” half has zones 8 to 14, and the “back” half zones 1 to 7. The configuration of the zones can also be thought of as seven axial pairs, these being 1 & 13, 2 & 14, 3 & 10, 4 & 11, 5 & 12, 6 & 8, 7 & 9. As illustrated, there are three compartments in each of the two zone controller units that traverse the central zones, namely 3, 4, 5 and 10, 11, 12 respectively, and two compartments in each of the four zone controller units that traverse the outer zones, these being 1 & 2, 6 & 7, 8 & 9, 13 & 14.

(3) The Reactor Regulating System controls the level of water in each compartment. If all the zone levels increase, there will be a negative reactivity change, and the neutron flux will decrease. Increasing or decreasing the level of water in all the compartments by the same amount changes the total or bulk reactor power. Note on the diagram that all the zones have the same level, indicating a uniform flux distribution.

(4) The Reactor Regulating System can also change the water level in each zone compartment by different amounts. In this way the neutron flux shape can be altered to different values in the various zones, while keeping the overall power level constant. In the diagram, I am illustrating a side to side as well as a back to front flux tilt and the corresponding differences in zone levels.

▶▶ 4.1 LIQUID ZONES

- ▶▶ (1) In a heavy water moderated and cooled reactor, light water can be used as a reactivity control device. By varying the amount of light water in the core (and in a given region of the core), the neutron flux can be controlled. This distributed system of variable amounts of light water volumes is called the "liquid zone control system".
- ▶▶ (2) In CANDU reactors, the principal means of fine bulk reactivity as well as spatial reactivity control is achieved by varying the amount of light water in 14 compartments that are located at the centres of the zones. As shown on the diagram, the 14 zones are distributed in two axial halves of seven. In the centre of each half there are three "zones", while the two outside regions have two "zones" each.
- ▶▶ (3) Bulk reactor power can be changed by increasing or decreasing the level of water in all compartments by the same amount.
- ▶▶ (4) The neutron flux shape can be altered by differentially altering the levels in the various zones, while keeping the overall power level constant.

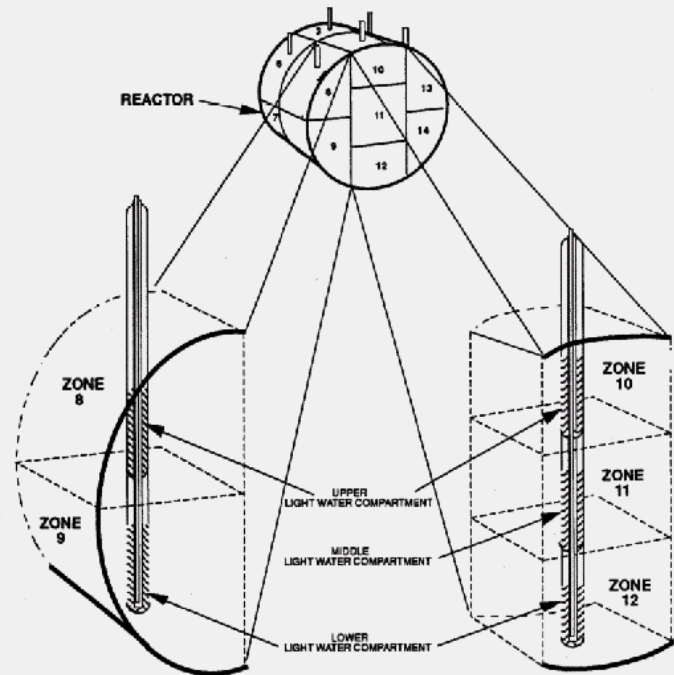

4.2 LIQUID ZONE LEVEL CONTROL SYSTEM

The area of each cylindrical light water zone compartment is fixed, so the volume of water, and hence its reactivity worth can be varied by controlling the level of the water in each compartment. Since the purpose of level control is to control the flux, both neutron flux and zone compartment water level need to be measured in order to ensure that the control system is behaving as intended. In this section we look at a somewhat simplified system of a liquid zone controller.

- (1) Near the centre of each zone there is a flux detector that measures the local flux, as shown by arrow (a). The output of the flux detector is read by the Digital Control Computer (DCC), as indicated by arrow (b). After some processing in the DCC, this signal is compared with the flux setpoint that is also calculated by the Reactor Regulating System (RRS) in the DCC. On each iteration of RRS the program computes a control signal based on the error between the setpoint and the flux measurement.

In case of a Reactor Trip the computer generates a control signal to fill zones at a rate of 0.5%FP/sec, while on a Reactor Setback the control signal is for a 0.15%FP/sec fill rate.

The control signal output from the DCC is at arrow (c), and is applied to a current to air pressure transducer.

- (2) The control signal, in the form of air pressure, is applied to a valve that varies the flow of water into the zone compartment. The valve is of the "air to close" type, as indicated by the A/C symbol.
- (3) The outflow from the zone compartment is kept at a constant value, so any changes in the inflow will alter the amount of water in the compartment, and hence its level. The constant outflow is achieved by keeping the Helium pressure above the water surface at a constant value, by a system of Helium feed and bleed, that is adding or removing Helium as needed to keep the gas pressure in the compartment at a constant value.
- (4) The DCC also measures the actual water level in each compartment, and ensures that no zone goes completely empty or full.
- (5) A system of Helium cover gas above the water and a controlled inflow of Helium to the bottom of the compartment are used to measure the water level.

▶ 4.2 LIQUID ZONE LEVEL CONTROL SYSTEM

The method of controlling the flux in a given region of the reactor by varying the level of water in a liquid zone compartment is shown in the diagram.

- ▶ (1) A flux detector measures the local flux, and this is compared with the flux setpoint in the Digital Control Computer (DCC), and a control signal is generated by the error between the setpoint and the flux measurement.
- ▶ (2) The error signal is applied to a valve that controls the flow of water into the zone compartment.
- ▶ (3) The outflow from the zone compartment is kept at a constant value, so any changes in the inflow will alter the amount of water in the compartment, and hence its level.
- ▶ (4) The DCC also measures the actual water level in each compartment, and ensures that no zone goes completely empty or full.
- ▶ (5) A system of Helium cover gas above the water and a controlled inflow of Helium to the bottom of the compartment are used to measure the water level.

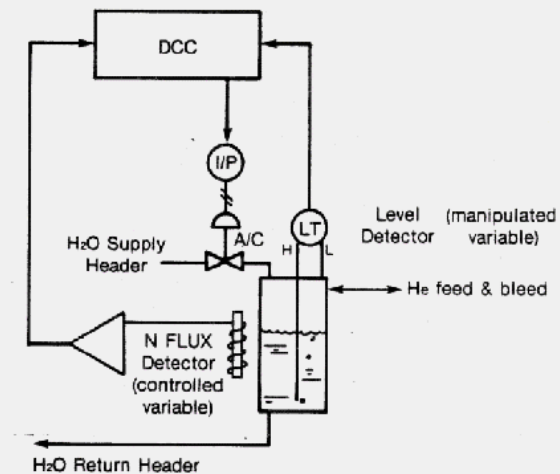

4.3 ADJUSTER RODS

The liquid zones, as described in the previous three sections, are the principal means of fine bulk reactivity as well as spatial flux control. However, the limited range of reactivity change between empty and full for all the zones, and the differential reactivity changes that can be realized by the relative levels between zones require other, more coarse methods of reactivity control. Solid neutron absorbers in the form of control rods are used to provide reactivity control beyond the capabilities of the liquid zone system. In CANDU reactors, these control rods are called either Adjusters or Mechanical Control Absorbers, depending on their function and design. In this section we look at Adjuster Rods, and in the next section I will briefly describe the Mechanical Control Absorbers.

(1) In CANDU reactors, there are three rows of Adjuster Rods as shown in the upper diagram. All three rows have the same arrangement, with the rods being located symmetrically relative to the centre line of the reactor. The rods near the outer parts of the core are shorter than the ones closer to the middle, to follow the circular shape of the core. In CANDU 6 reactors there are 21 Adjuster Rods, and for CANDU 9 reactors 24 Adjusters are used. The Adjuster Rods have the following three purposes:

- (a) As shown in the diagram, the neutron flux without the Adjuster Rods would have a cosine shape. A reactor with this neutron flux and power distribution would only be able to produce maximum power from the bundles near the centre of the core, all the other bundles would be producing less and less power as their position moved away from the centre.

To achieve maximum reactor power and fuel burnup, as many as possible of the fuel bundles should be producing power at their rated value. This requires flattening, or “adjusting” the flux, as shown in the diagram, with the use of the Adjuster Rods. Hence the name for these control rods. Of course there is a penalty in terms of fuel burn-up, as the Adjuster Rods absorb some of the neutrons that could otherwise cause fission.

- (b) The liquid zone controllers, as described previously, have a limited range of reactivity control. If there is a need to supply positive reactivity beyond the normal control range of the zone controllers, typically in the case when the zone controller water levels have been reduced as much as possible, withdrawal of Adjuster Rods can provide additional positive reactivity. Such situations may arise during fast power increases, or if there has been a delay in refuelling the reactor.
- (c) If reactor power is reduced significantly after prolonged, at least several days of operation at a given, usually 100% full power level, Xenon poison will build up in the core. By withdrawing the Adjuster Rods, the negative reactivity effect of Xenon can be compensated up to the reactivity worth of the Adjuster Rods. In case of a fast reactor shutdown such as a reactor trip from 100% full power, the complete withdrawal of all the Adjuster Rods will be able to compensate for the Xenon poison for typically 35 minutes. This is called the “poison override” time.

4.3 ADJUSTER RODS

- (1) The adjuster rods are provided to:
- shape the neutron flux for optimum reactor power and fuel burnup;
 - supply positive reactivity beyond the normal control range of the zone controllers when required;
 - compensate for the negative xenon reactivity, for typically up to 35 minutes after a shutdown from full power ("poison override").
- (2) In a CANDU 9 core there are 24 adjuster rods:
- the rods are made of stainless steel;
 - they are arranged in three rows each containing eight rods;
 - the rods are normally fully inserted in the core;
 - the rods are moved in banks;
 - the maximum total reactivity which may be gained on withdrawal of all adjuster rods is about 17 mk;
 - the maximum reactivity change rate of any one bank of adjusters is ± 0.07 mk/s.
 - the operation of the adjusters is normally controlled by the reactor regulating system, but can also be manually operated under prescribed conditions.

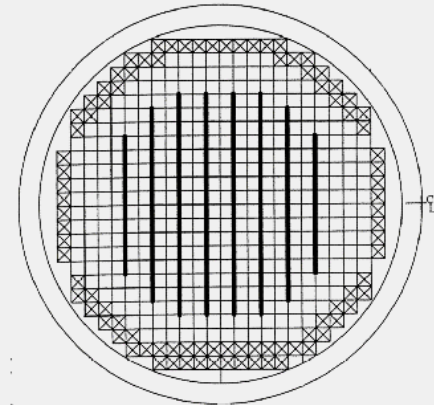
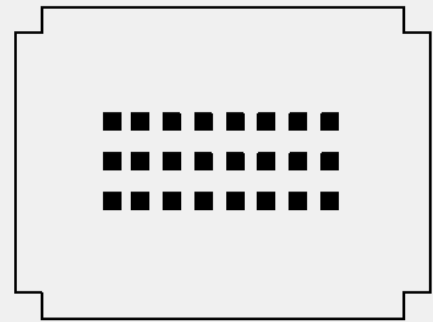

- (2) In a CANDU 9 core there are 24 adjuster rods, made of stainless steel.

The rods are arranged in three rows across the radial direction of the core, with each row containing eight rods. The rods are normally fully inserted in the core to shape the flux and to be a source of positive reactivity.

The Adjuster Rods, as all reactivity control mechanisms, are normally moved by the Reactor Regulating System to control bulk reactor power. When such movements take place, they involve a pre-designated group of rods, since the movement of a single rod would not normally provide a sufficient rate of reactivity change. Each such group of rods is called a "bank". There are eight banks of Adjuster Rods in a CANDU 9 reactor. The banks are designed to have approximately equal reactivity values, so banks containing rods in high flux regions will have two rods, intermediate flux regions will have three, and low flux regions four Adjuster Rods in the bank. The rods in a bank are chosen so that their withdrawal will not cause excessive flux distortions, and the banks are designed to be withdrawn in a sequence that also minimizes distortion of the spatial flux. Conversely, since as the Adjusters are withdrawn the flux will tend to assume the cosine shape, the maximum power that the reactor can produce is limited by the number of Adjuster Rods that are not fully inserted, that is partially or fully withdrawn, from the core.

The maximum total reactivity that may be gained on withdrawal of all adjuster rods is in the order of 16 - 18 mk, and the maximum reactivity change rate of any one bank of adjusters is ± 0.07 mk/second.

As I mentioned earlier, the operation of the adjusters is normally controlled by the reactor regulating system, but they can also be operated manually under prescribed conditions.

4.4 MECHANICAL CONTROL ABSORBERS

As described in the previous two sections, the liquid zones have limited range of reactivity control, and solid neutron absorbers in the form of control rods are used to provide reactivity control beyond the capabilities of the liquid zone system. In CANDU reactors, these control rods are called either Adjusters or Mechanical Control Absorbers, depending on their function and design. In Section 5 we looked at the Adjuster Rods, which can provide additional positive reactivity by withdrawal from the core. In this section I will briefly describe how additional negative reactivity can be realized by inserting the Mechanical Control Absorber Rods into the core.

- (1) In CANDU 6 and 9 reactors there are four mechanical control absorber rods or MCAs, as shown in the diagram. They consist of tubes of cadmium sandwiched between stainless steel tubes.
- (2) The normal position of the Control Absorbers is out of the core, i.e. they are “poised” for insertion when needed. Such need typically arises during power level changes, particularly during large power level reductions, in part due to the temperature effects that result in an inherent reactivity increase on a power level reduction. The MCAs are also designed to realize a rapid step-like reduction in reactor power when required by “Stepback” conditions.
- (3) The Mechanical Control Absorbers, as all reactivity control mechanisms, are normally moved by the Reactor Regulating System to control bulk reactor power. They can be driven into the core to supplement the negative reactivity of the liquid zone control units, or dropped partially into the reactor to affect a fast reactor power reduction of typically 40%FP, called a stepback. On a reactor trip the MCAs are fully dropped into the core to assist fast reactor shutdown. It is also possible to operate the Control Absorbers manually under prescribed conditions.
- (4) For normal reactivity control purposes the Mechanical Control Absorbers are driven into or out of the reactor core by the Reactor Regulating System in one of two banks. At full speed the rods can cover the full travel distance in 150 seconds. The actual driving speed can be varied by the Reactor Regulating System from 50% to 100% of full speed, depending on the power error.
- (5) When required to achieve a sudden reduction of reactor power the MCAs can be dropped by releasing their clutches. When dropped, the elements are fully inserted into the core in three seconds.
- (6) If only a partial reduction of reactor power is required, for example a step-like reduction by 40% FP, the clutches can be re-energized while the elements are dropping to achieve a partial insertion to any intermediate position.
- (7) The total reactivity worth of the four Mechanical Control Absorbers is about 10 mk.

4.4 MECHANICAL CONTROL ABSORBERS

- ▶ (1) there are four mechanical control absorber rods (MCAs), that consist of tubes of cadmium sandwiched between stainless steel;
- ▶ (2) the normal position of the Control Absorbers is out of the core, i.e. they are “poised” for insertion when needed;
- ▶ (3) they are driven in by the reactor control system to supplement the negative reactivity of the liquid zone control units, or dropped to affect a fast reactor power reduction (stepback);
- ▶ (4) the Control Absorbers can be driven into or out of the reactor core in one of two banks, at variable speed;
- ▶ (5) they can be dropped by releasing their clutches; when dropped, the elements are fully inserted in three seconds;
- ▶ (6) by re-energizing the clutch while the elements are dropping, a partial insertion to any intermediate position can be achieved;
- ▶ (7) the maximum total reactivity worth of the mechanical control absorbers is about 10 mk.

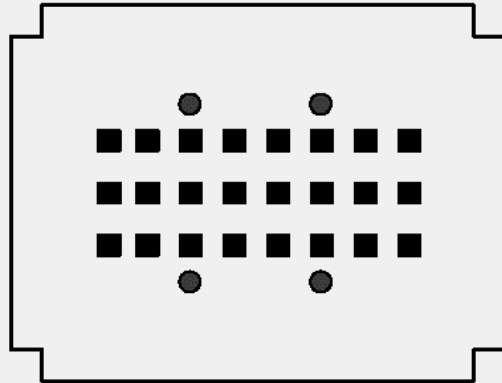

4.5 SHUTDOWN RODS

CANDU 6 and 9 reactors have two fully independent reactor shutdown systems, and these are also independent of the systems and components used for reactor regulation. The Shutdown Rods provide the means of large reactivity insertion for Shutdown System Number One, in short SDS#1, in the form of 32 solid neutron absorbing rods that are dropped into the core on an SDS#1 initiated reactor trip. The arrangement of the 32 rods is shown in top view on the diagram.

- (1) The Shutdown Rods are very similar in construction to the Control Absorbers, consisting of tubes of cadmium sandwiched between stainless steel tubes. The normal position of the Shutdown Rods is out of the core, i.e. they are “poised” for insertion when the reactor needs to be rapidly shut down. Shutdown Rods in the out-of-core position are indicated by arrows (a), and in the fully inserted position by arrows (b) on the diagram.
- (2) When all 32 Shutdown Rods are in their fully inserted position, their total reactivity worth is between -60 and -70 mk. The reactivity worth of the Shutdown Rods is such that in the case of two of the most effective rods not dropping into the core, the reactor will still be safely shut down for all design basis accidents.
- (3) In order to increase the speed of insertion for the Shutdown Rods, a small accelerating force is applied to them in the form of a compressed spring that covers the top 0.6 metres of travel for each rod. With this spring assisted gravity drop, the Shutdown Rods are fully inserted in 2 seconds.
- (4) The withdrawal of the Shutdown Rods is controlled by the Reactor Regulating System, by driving the motor that withdraws the Shutdown Rods. However, the clutch between the motor and the shaft that pulls the Rods is part of the Safety System. Until the clutch is energized and closed, the rods cannot be pulled. This design achieves the desired independence between Reactor Shutdown and Regulation.
- (5) The Shutdown Rods are withdrawn as soon as the trip signal has been cleared and the trip has been reset by the operator.
- (6) The Shutdown Rods are grouped into two banks, and are withdrawn one bank at a time.
- (7) Withdrawal of the Shutdown Rods is interrupted if:
 - control is switched to manual, or
 - the flux power error is excessive, or
 - the reactor is tripped, or
 - the log-rate exceeds 7 percent per second.

▶▶ 4.5 SHUTDOWN RODS

- ▶▶ (1) 32 rods of cadmium and stainless steel;
- ▶▶ (2) reactivity worth is -60 to -70 mk;
- ▶▶ (3) spring assisted gravity drop, fully inserted in 2 seconds;
- ▶▶ (4) normal withdrawal is controlled by the regulating system;
- ▶▶ (5) the shutdown rods are withdrawn as soon as the trip signal has been cleared and the trip has been reset by the operator;
- ▶▶ (6) the shutdown rods are grouped into two banks, and are withdrawn one bank at a time;
- ▶▶ (7) withdrawal of the shutdown rods is interrupted if:
 - control is switched to manual, or
 - the flux power error is excessive, or
 - the reactor is tripped, or
 - the log-rate exceeds 7 percent per second.

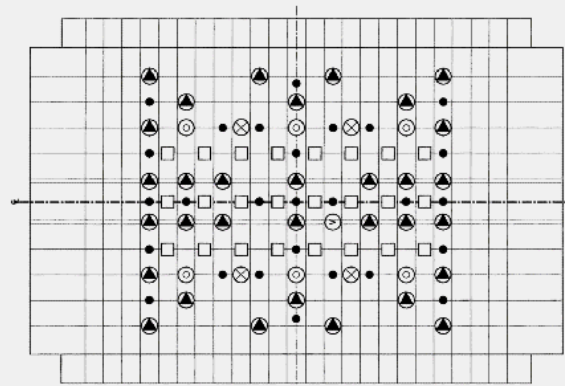

 ADJUSTER	 ZONE CONTROLLER	 VERTICAL FLUX DETECTOR
 CONTROL ABSORBER	 SHUTDOWN ROD (SA)	 VIEWING PORT

4.6 SUMMARY OF REACTIVITY CONTROL DEVICES

All the reactivity devices considered in this Section, for regulation as well as shutdown purposes, are installed from above the Calandria. The drive motors, connections for electrical, water and Helium supplies are all made at the Reactivity Mechanism Deck. Because the solid control rods, including Adjusters, Control Absorbers and Shutdown Rods need to travel from being fully inserted into the core to a position that is completely out of the core, there must be sufficient distance between the top of the Calandria and the bottom of the Reactivity Mechanism Deck to make room for these rods in their out of core positions. All the reactivity devices in CANDU 6 and 9 are neutron absorbers, and they function by having more or less neutron absorbing material in the reactor. Control is provided for the following effects:

- (1) Long-term bulk reactivity is mainly controlled by on-power refuelling. This is the only method for adding absolute positive reactivity to the core, instead of only reducing the amount of negative reactivity.
- (2) Small, frequent reactivity changes, for both global and spatial neutron power, are controlled by the liquid zone control system.
- (3) Positive reactivity for xenon override and fuelling machine unavailability, is provided by withdrawing Adjuster Rods from their normal position in the core shown as (a) to their "parked" position above the Calandria, at position (b).
- (4) Negative reactivity to supplement the liquid zones, particularly for fast power reductions and to override the negative fuel temperature effect for large power level decreases, is provided by the insertion of mechanical control absorbers from their normal "poised position" at (a), to part way or all the way to their fully inserted position at (b).
- (5) Excess reactivity due to fresh fuel and decay of xenon following a long shutdown, are compensated by adding poison to the moderator.
- (6) Rapid shutdown of the reactor is by dropping solid control absorbers (shutdown rods) into the core, from position (a) to position (b), and/or by the fast injection of large amounts of liquid poison into the moderator, as indicated by arrow (c).

▶ 4.6 SUMMARY OF REACTIVITY CONTROL DEVICES

Reactivity control devices are provided to alter the rate of neutron multiplication (either as controllers or as shutdown devices). Control is provided for the following effects:

- ▶ (1) long-term bulk reactivity, mainly controlled by on-power fuelling;
- ▶ (2) small, frequent reactivity changes, both global and spatial, controlled by the liquid zone control system;
- ▶ (3) additional positive reactivity for xenon override and fuelling machine unavailability, compensated by the withdrawal of adjuster rods;
- ▶ (4) additional negative reactivity for fast power reductions and to override the negative fuel temperature effect, provided by the insertion of mechanical control absorbers;
- ▶ (5) excess reactivity due to fresh fuel and decay of xenon following a long shutdown, are compensated by adding poison to the moderator;
- ▶ (6) rapid shutdown of the reactor is by dropping solid control absorbers (shutdown rods) into the core, and/or by the fast injection of large amounts of liquid poison into the moderator.

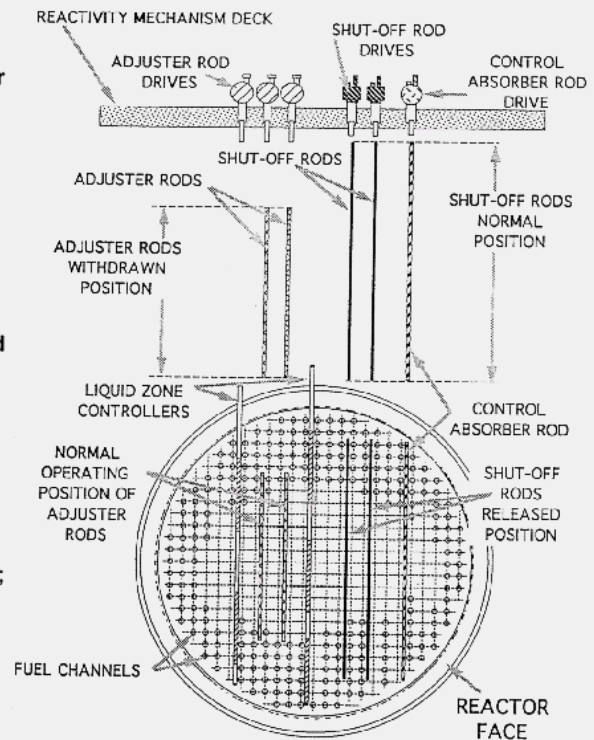

5. REACTOR REGULATING SYSTEM (RRS)

The next few pages present the instrumentation and signal processing used by the Reactor Regulating System. Included are the various methods of Neutron Flux and Thermal Power Measurements, and how they are combined to determine actual reactor power. The control algorithms are implemented as computer programs that receive the measurement signals, process them, and using the reactor setpoint, compute the demanded power and the power error. The control programs determine which reactivity mechanism is to move, by what amount and at what rate. RRS is designed to perform the following functions:

- (1) Automatic control of reactor power to a given setpoint, and maneuvering between any two power levels between $10^{-5}\%FP$ and $100\%FP$.
- (2) Maintaining the neutron flux distribution close to its nominal design shape.
- (3) Insertion or removal of reactivity devices at controlled rates to maintain a reactivity balance in the core.
- (4) Monitoring of a number of important plant parameters and reduction of reactor power when any of these parameters is out of limits.
- (5) Withdrawal of shutdown rods from the reactor automatically when the trip channels have been reset following reactor trip on SDS#1.



5. REACTOR REGULATING SYSTEM (RRS)

The next few pages present the instrumentation and signal processing used by the Reactor Regulating System. Included are the various methods of Neutron Flux and Thermal Power Measurements, and how they are combined to determine actual reactor power. The control algorithms are implemented as computer programs that receive the measurement signals, process them, and using the reactor setpoint, compute the demanded power and the power error. The control programs determine which reactivity mechanism is to move, by what amount and at what rate. RRS is designed to perform the following functions:

- (1) Automatic control of reactor power to a given setpoint, and maneuvering between any two power levels between 10⁻⁵%FP and 100%FP.
- (2) Maintaining the neutron flux distribution close to its nominal design shape.
- (3) Insertion or removal of reactivity devices at controlled rates to maintain a reactivity balance in the core.
- (4) Monitoring of a number of important plant parameters and reduction of reactor power when any of these parameters is out of limits.
- (5) Withdrawal of shutdown rods from the reactor automatically when the trip channels have been reset following reactor trip on SDS#1.

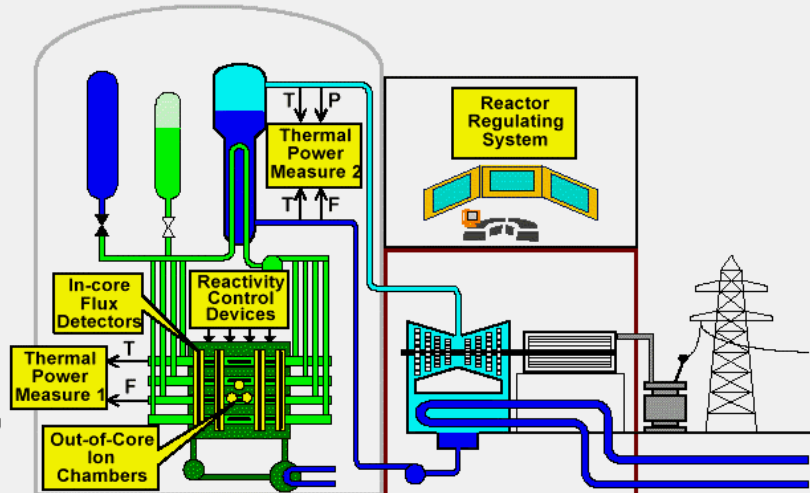

5.1 REGULATING SYSTEM ION CHAMBERS

- (1) There are three horizontally mounted ion chamber assemblies of the type shown on the previous diagram at the side of the calandria. One ion chamber from each housing supplies a signal for the purpose of reactor regulation that is fed to an amplifier. The amplifier processes the input signal from the ion chamber so as to produce three different output signals. Each of these signals, and remember that there are three such amplifiers so that each of these signals is in fact triplicated, are used for different purposes:
 - (a) The range of the Linear N signals is from 0 to 150 %FP, and they are connected to indicating meters on the Main Control Room Panels.
 - (b) The range of the Log N signals are from 10^{-5} to 150 %FP. These signals are displayed on the Main Control Room Panels, and they are connected as Analogue Inputs shown as A/I, to both digital control computers DCC'X' and DCC'Y'.
 - (c) The range of the Log N Rate signal are from -15 to +15 %/sec. These signals are displayed in the Main Control Room and are connected as A/Is to both DCCs.
 - (2) Since the ion chamber signal is based on a measurement of the leakage flux, it is not an accurate measure of the absolute value of the flux inside the reactor. Hence the Lin N signal cannot be used directly to control reactor power, but it is a useful indication to have in the Control Room.
 - (3) At low power levels the inaccuracy of the ion chamber reading due to local flux distortions is relatively small and not so significant, so at low power levels the Log N signal can be used directly for control of reactor power. It is used by the Reactor Regulating System (RRS) to control power below 15%FP.
 - (4) The Log N Rate signal is not affected by the inaccuracies in the absolute value of the ion chamber signal, since it is only concerned with the rate of change of the signal. The Log N Rate signal is used in RRS as part of the power error calculation. It is also used to generate a Stepback signal on high Log N Rate.

5.2 IN-CORE VERTICAL FLUX DETECTORS FOR THE REACTOR REGULATING SYSTEM

For the control of the reactor power in the linear or power generation range, from above 5%FP, CANDUs use the Inconel type in-core flux detectors. These detectors are located in the 14 control zones, so that both the spatial distribution and the total flux of the reactor are measured and controlled. The diagram illustrates a segment of the core, in a region that includes 16 fuel channels, and shows one such in-core flux detector between the row of fuel channels and spanning a distance of approximately three lattice pitches.

There is a distinction between the Vertical In-Core Flux Detectors used for reactor regulation and the Horizontal in-Core Flux Detectors used for the second reactor shutdown system.

- (1) In CANDU reactors there are 28 in-core Vertical Flux Detectors (VFDs) using Platinum clad Inconel to measure the neutron flux in each of the 14 reactor zones. Each zone has two detectors to provide redundancy, and as shown on the diagram, the two detectors from the same zone are connected to two different amplifiers.
 - (a) Although these detectors are “self-powered” as I explained in the previous section, the signals generated by the detectors need to be amplified before they can be connected to the DCCs. The design has two amplifiers supplied from a given 120V Class 2 source, and to ensure redundancy, each of a pair of amplifiers receives its input signal from a VSD located in two different zones, as illustrated.
 - (b) Each amplifier outputs a Lin N signal that is connected as A/I to both DCCs. It is this Linear Neutron signal that is used by the Reactor Regulating System (RRS) to control power above 5%FP, both spatially and for the reactor as a whole. However, because of the gamma sensitivities and discussed in the previous section, the flux detector signals cannot be used directly for the control of reactor power, but need some corrections. The bulk power measurement needs to be calibrated by the thermal power measurements, while for the purpose of controlling the spatial power distribution, the calibration uses the output of the Flux Mapping routine.
- (2) The Vanadium detectors I described in the previous section are used for the purpose of determining an accurate distribution of the neutron flux in the reactor by the use of a Flux Mapping routine.

In CANDU 6 reactors there are 102, and for CANDU 9 reactors there are 120 Vanadium detectors distributed throughout the core to measure the local flux. Following amplification these local flux readings are connected as A/Is to both DCCs. The computers use these signals as input to a mathematical representation of the flux shapes, and the programs output estimates of the flux distribution every 2 minutes. These estimates are accurate linear measures of the flux shape throughout the reactor, but due to the 5.5 minute half-life of V-52 the desired accuracy is not reached for about 25 minutes following a change of neutron flux.

The output of the Flux Mapping Routine is used to calibrate the Inconel flux detector readings for the purpose of fine tuning the zonal power measurement and control, as well as to reduce reactor power if excessive local power peaks are detected.

5.2 IN-CORE VERTICAL FLUX DETECTORS FOR THE REACTOR REGULATING SYSTEM

(1) There are 28 in-core Vertical Flux Detectors (VFDs) using Platinum clad Inconel to measure the neutron flux in each of the 14 reactor zones. Each zone has two detectors to provide redundancy.

(a) two amplifiers are supplied from a given 120V Class 2 source, and each receives a signal from a VSD located in two different zones;

(b) each amplifier outputs a Lin N signal that is connected as A/I to both DCCs; the Lin N signal is used by the Reactor Regulating System (RRS) to control power above 5%FP .

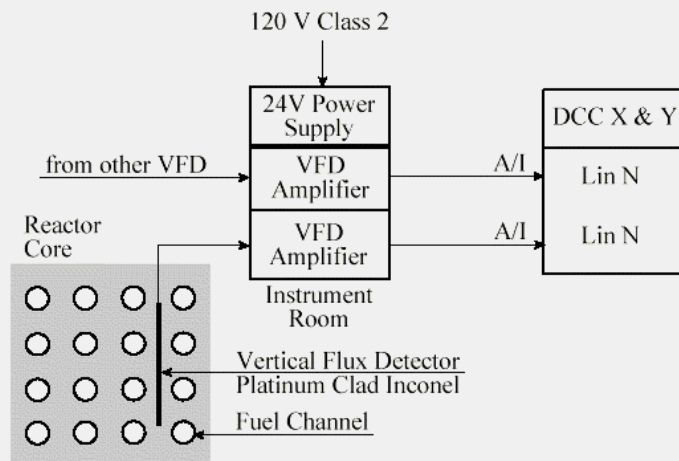

(2) Vanadium detectors for Flux Mapping

- in CANDU 6 reactors there are 102, and for CANDU 9 reactors there are 120 detectors distributed throughout the core;
- following amplification these local flux readings are connected as A/I's to both DCCs;
- they provide an accurate linear measure of the local flux and are used to compute a flux shape throughout the reactor, but are delayed by up to 25 minutes due to the half-life of V-52;
- the computed flux shapes are used to reduce reactor power if excessive local power peaks are detected.

5.3 THERMAL POWER MEASUREMENT

So far in this Section we have been dealing with the methods used for measuring the neutron flux. I have mentioned that neither the ion chamber nor the in-core detector signals are sufficiently accurate to be used directly, that is without some correction, for the purpose of controlling reactor power, particularly when that power becomes significant at and above 5%FP. While the neutron flux is the “primary” variable of concern, the power generated by that neutron flux is both the useful output and the parameter that needs to be accurately measured and controlled. Although one can compute the relationship between neutron flux and power output, it is desirable to have a continuous and accurate measure of the thermal power produced by the reactor. In this section we look at the two principal means of measuring the thermal power output of the reactor.

(1) Heat Output from the Reactor

The useful heat output of a CANDU reactor appears in the fuel channels, in the form of heat transferred from the fuel to the heat transport system coolant. This heat is subsequently transferred to the light water on the secondary side of the steam generators. There are therefore two principal places for measuring the thermal output of the reactor: one is the heat transferred to the coolant as it flows through the reactor, and the other is the heat transferred to the feedwater between the time it enters the steam generator until it leaves as steam. Let us look at measuring the heat transfer in the reactor first.

- (a) The heat transferred from the fuel coolant can be determined by measuring the flow rate and the temperature difference between fuel channel inlet and outlet. The coolant flow can be accurately measured using venturies, orifice plates and similar devices, and in any case is fairly constant throughout the power levels of interest.
- (b) Accurate temperature readings of the coolant at the fuel channel inlet and outlet can also be obtained, but only following a time delay. The temperature measurements are made with Resistance Temperature Detectors (RTDs) mounted on the feeder pipes. Due to the time it takes for the coolant to reach the detector, called the transport lag, and the time constant of the sensor itself, there is a delay from the time the fuel temperature changes until this change registers as a correct reading at the RTDs.
- (c) An even bigger problem with this method of measuring heat transfer is that the temperature change will only be an accurate measure of heat input if there is no boiling in the fuel channel. For CANDU 9 boiling begins at 75%FP, so temperature measurements above 75%FP will begin to give inaccurate readings as power level rises. Therefore, to determine thermal power above 75%FP, we need to look at the suitability of using the measurements across the steam generators.

(2) Heat Input to the Steam Generators

By measuring steam flow and temperature, as well as feedwater flow and temperature, the amount of heat transferred across the steam generators can be determined. Because the steam is at saturation conditions, it is in fact easier to measure steam pressure and compute the corresponding temperature. From these measurements an accurate value for the heat transferred to the boilers can be obtained, but the transport lag is much longer than in the case of the coolant temperature measurement.

5.3 THERMAL POWER MEASUREMENT

▶ (1) Heat Output from the Reactor

- ▶ (a) Measure the coolant flow through the reactor and the temperature increase; coolant flow can be accurately measured using venturies, orifice plates and similar devices.
- ▶ (b) An accurate temperature reading of the coolant can also be obtained, but only following a time delay. Due to transport lags, and the time constant of the sensor, there is a delay from the time the fuel temperature changes until this change registers as a correct reading at the sensor.
- ▶ (c) The temperature change will only be an accurate measure of heat input if there is no boiling in the fuel channel. For CANDU 9 boiling begins at 50%FP, so temperature measurements above 50%FP will begin to give inaccurate readings as power level rises.

▶ (2) Heat Input to the Steam Generators

Measure steam flow and saturation pressure (and hence temperature), as well as feedwater flow and temperature.

From these measurements an accurate value for the heat transferred to the boilers can be obtained, but with an even longer time delay than in the case of the coolant temperature measurement.

- ▶ (3) Below 50%FP the temperature change across the reactor is used to calibrate the in-core flux detectors. Above 70%FP the heat transferred to the steam generators is used to calibrate the in-core flux detectors. In the intermediate range of 50% and 70%FP a linear combination of the two estimates is used as the calibration signal.

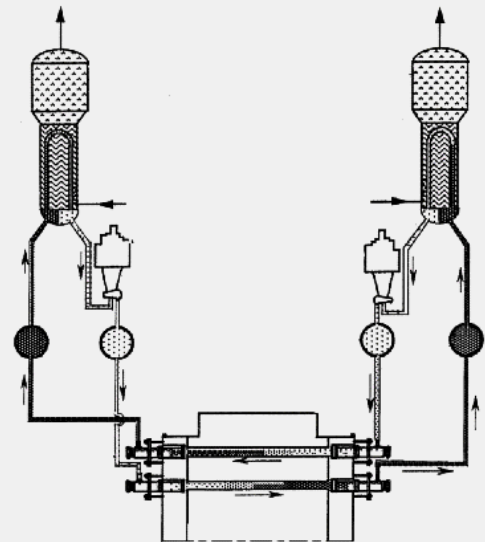

- (3) A combination of the above two measurements is needed to cover the complete power range. Below 50%FP the temperature change across the reactor is used, and above 70%FP the heat transferred to the steam generators is used to determine reactor thermal power. In the intermediate range of 50% and 70%FP a linear combination of the two estimates is used to obtain a smooth transfer from one signal source to the other, as shown on the diagram.

5.4 REACTOR POWER MEASUREMENT

A nuclear reactor operates over a very wide range of neutron flux levels. During initial start-up it can be as low as 10^{-14} of full power. Special start-up instruments that are not installed permanently are used at these very low levels. We will not deal with these in this course.

The neutron flux levels that need to be measured by the permanently installed instruments read flux levels from 10^{-5} to 150% of full power. It is very difficult to obtain accurate measurements over such a wide range. The type of instruments available and the restrictions on their placement result in additional difficulties in making accurate neutron flux and reactor power measurements. For these reasons a number of different devices and techniques are used to determine the flux distribution and the total power level of the reactor.

(1) Ion Chambers

The wide range of flux measurements are provided by three sets of ion chamber units. They are located on the outside of the calandria shell at arrow (1), and are therefore able to provide only an indirect measure of the average neutron flux inside the reactor. The ion chamber signal is processed by the instrumentation system, at arrow (2), to supply the following measurements to the Reactor Regulating System:

- log neutron power, 10^{-5} to 150% full power;
- linear neutron power, 0 to 150% full power;
- rate of change of log power, -15% to +15% of present power per second.

(2) Flux Detectors

In order to measure the neutron flux distribution inside the reactor, flux detectors are distributed throughout the core (arrow 1). These self-powered detectors cannot measure flux values below about 1%FP, and are used therefore to provide measurements of the local flux between 10% and 120% full power. The signals from these detectors are processed to give a linear measure of the neutron flux, both locally and for the overall power level of the reactor.

There are two types of in-core detectors, one uses Vanadium (arrow 2) and the other Platinum (arrow 3) as the detector material. The sheaths of both types are made of Inconel.

(a) Platinum flux detectors have fast response to changes in neutron flux, and can be used as the input signal to the Regulating System to control neutron power between 15% and 100%FP. Both the spatial flux distribution and the total reactor power level are controlled on the basis of the Platinum detectors.

The only problem with these detectors is that they respond not only to neutrons but also to gamma rays. In order to use these signals for reactor power level control, the signals from the Platinum detectors must be adjusted to remove the contribution of the gamma rays.

(b) The Vanadium flux detectors have the advantage that they are only sensitive to neutrons, but they cannot be used directly for reactor power control because of a relatively slow response to changes in neutron flux. The dominant time constant is about five minutes.

The Vanadium detectors are used as inputs to a flux mapping program, the output of which is used, along with the Thermal Power measurements, to adjust the Platinum detector readings for spatial flux control.

(3) Thermal Power

As noted earlier, because of their sensitivity to gamma rays, the Platinum in-core flux detector signals must be adjusted to ensure that an accurate measure of the neutron flux is obtained. The Platinum detector signals are calibrated by the use of thermal power measurements taken on the secondary side of the Steam Generators.

Steam flow, steam pressure, feedwater flow and feedwater temperature measurements are used to calculate the thermal power that is being transferred to the light water. This thermal power is a measure of the power produced by the reactor, although the signals will be delayed relative to the actual reactor power by approximately 20 seconds, due to thermal time constants and transport time. This delay does not effect the use of the thermal power measurement in calibrating the Platinum signal for the purpose of overall reactor power control.

5.4 REACTOR POWER MEASUREMENT

- (1) Ion Chambers
- (2) Flux Detectors
 - (a) Platinum - Flux Power
 - (b) Vanadium - Flux Map
- (3) Thermal Power

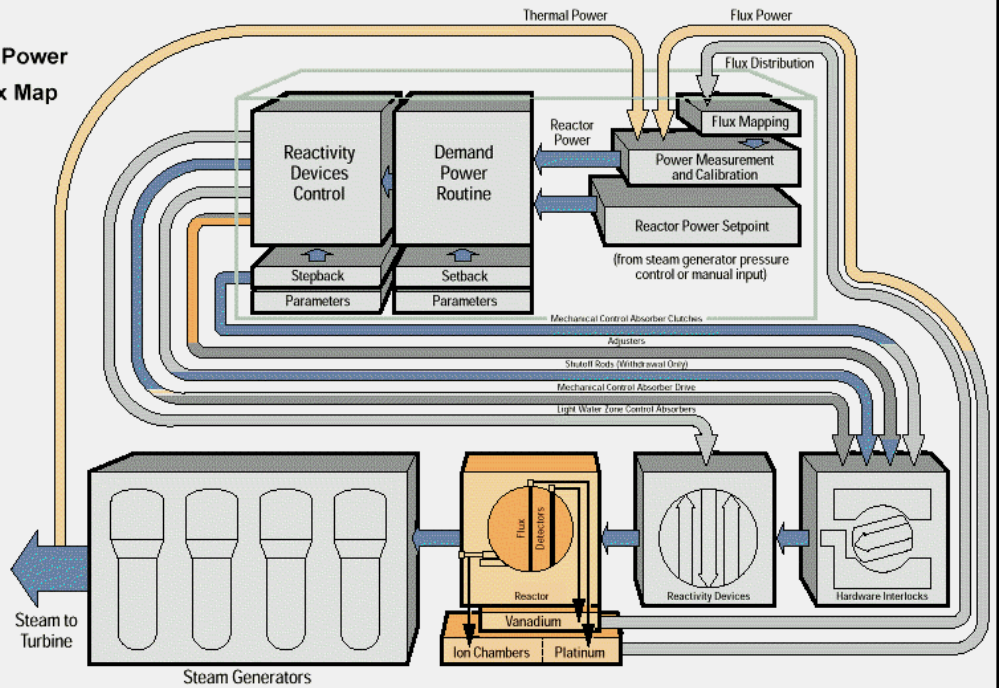

6. SIMPLIFIED REACTOR REGULATING SYSTEM BLOCK DIAGRAM

This simplified diagram shows the key components of the Reactor Regulating System. These are the Power Measurement, including both neutron and thermal power measurements, the computation of Power Error as the difference between Actual and Demanded Power, the Controller Algorithm that determines the response of the reactivity mechanisms to the power error, and certain other actions that can override the normal operation of the reactor regulating system.

- (1) We have studied in the previous sections how the various instruments and methods for measuring both reactor neutron and thermal power, and why no single measure of reactor power is acceptable as the basis of reactor control. I will only mention a few of the key factors here.
 - (a) In-core flux detectors provide a direct measure of the neutron flux in the reactor. By distributing these detectors in the core, the local flux in the 14 control zones, as well as at some 100 locations in the core can be measured. These measurements provide the basis for both spatial and overall reactor power control between 5%FP and 120%FP. However, because of gamma radiation and detector time constant, these measurements need to be calibrated against thermal power measurements to achieve the desired accuracy. Also, at power levels below 5%, the in-core flux detector do not provide a sufficient signal strength, so at low power levels the neutron flux is measured by ion chambers. These instruments are located just outside the calandria, so they measure the leakage flux, and therefore their readings are not an accurate measure of either the average flux or of its distribution in the core. However, at low power levels, and for rate of change of flux measurements, neither of these shortfalls is a problem.
 - (b) As I mentioned in item (1a), the in-core flux detector readings need to be calibrated against direct measurements of thermal power. Such measurements can be made at the reactor, by knowing the coolant flow and its temperature change across the reactor. Such a measurement will give an accurate value for heat transferred from the fuel to the coolant, provided no boiling of the coolant takes place. In CANDU 9 boiling begins at 50 degrees centigrade, so above this power level an alternate method of thermal power measurement is needed. This is provided by measuring the heat transferred to the feedwater in the steam generator, by measuring feedwater flow and temperature and steam flow and pressure. From the steam pressure reading the temperature can be calculated, since the steam is at saturation conditions. The computation of heat transferred across the steam generator is more accurate at higher power levels, so there is a transfer of thermal power computation from the reactor measurements to the steam generator measurements between 50-70%FP, and above 70%FP, thermal power measurement is based entirely on the steam generator parameters.
 - (c) Actual Reactor Power is computed by continuously calibrating the in-core flux detector readings by the thermal power measurements. Although the latter are delayed by transport lag and sensor time constant, these delays are not significant as long as reactor power changes near 1200%FP are taken at the slower rates. For the purpose of spatial flux control, the 14 zone flux detector signals are corrected on a several minute long time scale by the Flux Mapping program.

6. SIMPLIFIED REACTOR REGULATING SYSTEM BLOCK DIAGRAM

The key components of the Reactor Regulating System are shown on the diagram.

- ▶ (1) Power Measurement:
 - (a) Measurement of Neutron Flux.
 - (b) Measurement of Thermal Power.
 - (c) Determination of Actual Reactor Power.
- ▶ (2) Power Error Calculation.
 - (a) Setpoint Selection.
 - (b) Computation of Demanded Power.
 - (c) Power Error Magnitude and Rate.
- ▶ (3) Reactivity Device Control.
- ▶ (4) Other Actions
 - (a) Setback conditions.
 - (b) Stepback conditions.
 - (c) Reactor Trip.
 - (d) Reactor Trip Reset.

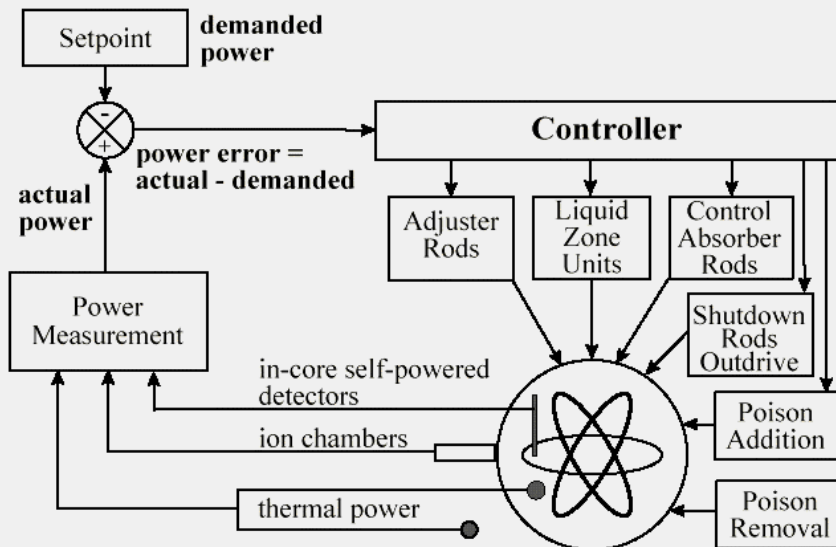

- (2) As we will see later in this Session, Power Error is a key parameter in determining the actions of the Reactor Regulating System. Calculation of the Power Error involves more than just subtracting demanded power from actual power.
 - (a) As you know from Session 1, the Reactor Power Setpoint is specified by the Steam Generator Pressure Control program if the unit is in Normal Mode, and by the Operator if the unit is in Alternate Mode of control. Both the target value of the setpoint and the desired rate of power level change are specified.
 - (b) From the specified target reactor power setpoint and its rate of change the Demanded Power Routine in RRS calculates the value of Demanded Power for each iteration of the computer program. Various limits are designed into the routine to ensure that reactor power is maneuvered at safe rates.
 - (c) The reactor power control algorithm has both a proportional term and a rate term. The proportional term is the difference between the magnitudes of actual and demanded power. The rate term is the difference between the rate of change of actual and demanded power. The effective power error is the sum of these two terms. When we say "power error", we mean this "effective power error".
- (3) The power error is the basis for determining which Reactivity Control Device to move and by what amount. The word "move" is appropriate not only for the solid control rods, but also for the liquid zones and for poison addition, since in each of these cases the control signal moves the appropriate control valve. This movement is usually expressed in terms of valve "lift" as the pneumatic controller effectively raises or lowers the valve stem.
- (4) As we will see in this Session, the actions of the controller can be influenced by and at times overridden by certain conditions. We will look at the following special conditions: Setback, Stepback, Reactor Trip and the Reset of a Reactor Trip

6.1 OVERVIEW OF THE CONTROL ALGORITHMS

- (1) The five main components of the CANDU Reactor Regulating System control algorithms are highlighted on the diagram. They are the selection of the Reactor Power Setpoint, Measurement of Actual Reactor Power, Calculation of Power Error, Control of the Reactivity Devices, and Reactor Stepback.
- (2) In Session 1 we looked at the two main sources of the Reactor setpoint. You recall that in Normal Mode, reactor power setpoint is determined by the steam generator pressure control program, so as to eliminate steam generator pressure error. The rate is always the same, 0.4%FP/sec

In Alternate Mode, the unit operator specifies via the keyboard the reactor power setpoint, and its rate of change.

There are two other possible sources of the reactor power setpoint, and both of these will override the previous two. Hold Power, as its name suggests, will stop any power changes and makes the setpoint equal to the demanded power at the time the Hold Power action was initiated.

Reactor Setback will make the setpoint equal to a value determined by the conditions indicating the need for a Setback, and will specify the rate of reduction that is also a function of the Setback conditions.

When I talk about the Reactor Setpoint, what I really mean is the target value to which reactor power should be raised. It would not be safe to request a sudden step increase in reactor power, so the target setpoint is reached at the specified rate. It is the Demanded Power routine which calculates for each computer iteration the incremental increase towards the target setpoint. The Demanded Power routine is executed every 0.5 second, and on each iteration the appropriate increment is added to or subtracted from the value of demanded power that was computed in the previous iteration. For example a rate of setpoint increase of 0.4%FP/second will result in Demanded Power increasing by 0.2%FP on each iteration, until Demanded Power reaches the Target Setpoint.

- (3) The Power Error Calculation is done for each of the 14 zones and for the total or bulk reactor power. In this course we will concern ourselves principally with the bulk power error only. This is the parameter that determines the main reactor regulating system actions, particularly when the liquid zones alone are not capable to provide the required change in reactivity.
- (4) As we will see in considerable detail later in this Session, the power error is the basic parameter that determines the movement of the reactivity control devices, although the average zone level also has an important role on the nature of the control action taken. For small changes in power error, and as long as the liquid zone levels are neither too empty nor too full, changes in liquid zone controller levels are the first and often the only reactivity mechanism actions needed to eliminate the power error.
If the average zone level falls too low, and/or the power error is excessively negative, in other words there is need for positive reactivity in the core, withdrawal of the adjuster rods will be initiated by RRS.

6.1 OVERVIEW OF THE CONTROL ALGORITHMS

- ▶▶ (1) The CANDU Reactor Regulating System control algorithms consist of the following main components:
- ▶▶ (2) Reactor setpoint calculations:
 - (a) normal mode;
 - (b) alternate mode;
 - (c) hold power;
 - (d) reactor setback;
 - (e) demanded power calculation.
- ▶▶ (3) Power error calculation.
- ▶▶ (4) Control of reactivity devices:
 - (a) liquid zone level control;
 - (b) adjuster rods;
 - (c) control absorber rods;
 - (d) adjuster and absorber speed control;
 - (e) poison addition;
 - (f) shutdown rods withdrawal.
- ▶▶ (5) Reactor stepback.

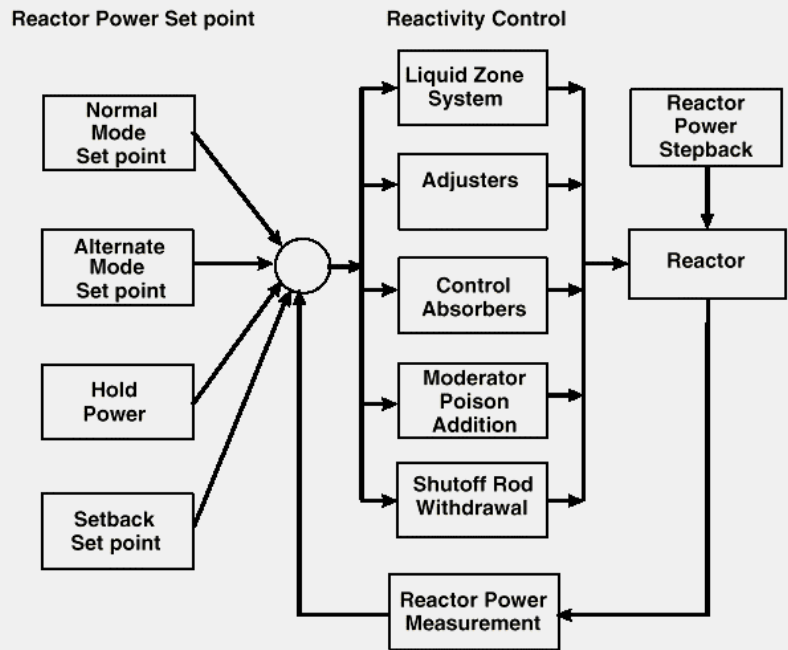

6.2 DEMANDED POWER ROUTINE

In the Demanded Power Routine of the Reactor Regulating System program the value of Demanded Reactor Power, which is in fact the value of the reactor power setpoint for that computer iteration, is calculated from the power change that was determined by the Reactor Setpoint program I described in the previous section.

The diagram illustrates the various factors that the program uses. The horizontal axis shows time in seconds and the vertical axis Reactor Power in %FP. The example illustrates the case of a power increase in ALTERNATE MODE.

- (1) The example is for a change in Target Reactor Power Setpoint from 70%FP to 80%FP at a rate of 0.8%FP/sec. The specified Target Reactor Power Setpoint is shown as a step change by the blue lines. Such a big change would cause an excessively large power error, so the Demanded Power level change is instead achieved by ramping the instantaneous setpoint up to the target value at the specified rate, in this example 0.8%FP/sec.
- (2) The Demanded Power Routine executes once in every 0.5 second. On each iteration the amount of change in demanded power is computed as a constant times the difference between the target and current values of the setpoint, and added to the value of demanded power from the previous iteration.
- (3) During large differences between Target Setpoint and Demanded Power, the specified rate of setpoint change is used as an upper limit on the step size per iteration, keeping the step changes between successive iterations small. Since the rate is specified per second, half of the nominal rate is the maximum amount that can be added on each program iteration. In the example, the maximum step increase in Demanded Power is 0.4%FP on each iteration.
- (4) As the Target Setpoint is approached, the difference between Target Setpoint and Demanded Power becomes progressively smaller, and the size of demanded power change on each iteration will decrease, resulting in a smooth approach to the Target Setpoint, minimizing the tendency for actual reactor power to overshoot the target value.
- (5) The diagram illustrates what happens on a "HOLD POWER" operation. In the upper part of the diagram you can see the step-wise increase in Demanded Power towards the Power Setpoint Target. In the lower part you see what happens on the iteration following the pressing of the HOLD POWER button: the Power Setpoint Target is set equal to the value Demanded Power has on that iteration, and the change in demanded power is stopped.
- (6) Although it may be possible for the operator to enter on the keyboard a incorrect values of Target Reactor Power Setpoint and Rate, the actual reactor power setpoint changes are limited by the control program to safe rates and upper limits.
- (7) Another part of the program includes a deviation limiter, which prevents the power setpoint from being more than 5% above the actual power. This feature is designed to preclude the possibility of a large power increase at excessive rates.

6.2 DEMANDED POWER ROUTINE

- (1) All power level changes are achieved by ramping the setpoint up or down at a specified rate, towards the specified target endpoint.
- (2) On each iteration the amount of change in demanded power is computed and added to the value of demanded power from the previous iteration.
- (3) During large differences between Target Setpoint and Demanded Power, the rate limit will keep the step increases between successive iterations small.
- (4) As the Target Setpoint is approached, the error becomes progressively smaller, and the size of demanded power change on each iteration will decrease, resulting in a smooth approach to the Target Setpoint, minimizing the tendency for actual reactor power to overshoot the target value.
- (5) On a "HOLD POWER" operation the change in demanded power is set equal to zero.
- (6) All reactor power setpoint changes are limited by the control program to safe rates and upper limits.
- (7) A deviation limiter prevents the power setpoint from being more than 5% above the actual power to preclude the possibility of a large power increase at excessive rates.

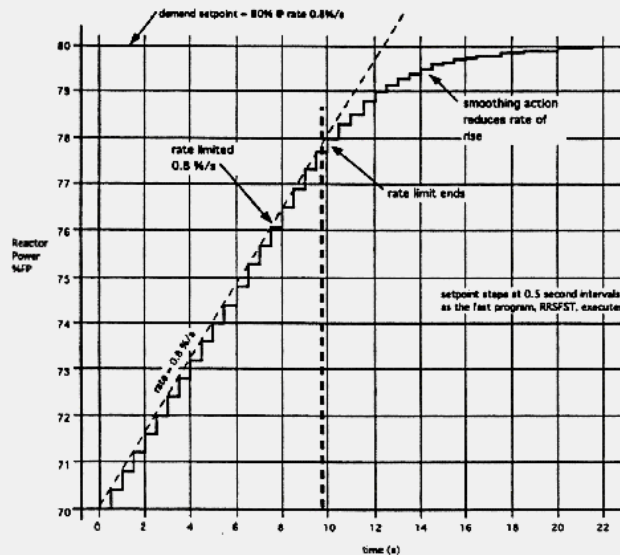

6.3 POWER ERROR CALCULATION

- (1) The bulk power error is a measure of the difference between the measured power and the demanded power of the reactor, plus a rate of change of power error term.

$$\text{power error} = k_1(\text{actual power} - \text{demanded power}) + k_2(\text{actual rate} - \text{demanded rate})$$

The unit of power error is %FP. In terms of control system design, this is a proportional plus derivative type of controller. The difference between actual and demanded power is the proportional term, and constant k_1 is the proportional gain. The difference between the actual and demanded rates is the derivative term, and k_2 the derivative gain constant.

This is a very important relationship, as it has a fundamental role in RRS determining the movements of reactivity devices.

- (2) The sign of the power error determines whether to
 - (a) increase or decrease the levels of the zones
 - (b) remove or insert adjuster rods
 - (c) remove or insert the mechanical control absorbers.

We will see the decision rules for each of these reactivity mechanism actions in the next few sections.

- (3) When the power error is zero, no movement of devices will be ordered, although device movements ordered before the error became zero will be completed.
- (4) Note that reactor power control is based entirely on the measurements of neutron and thermal power. Although the method of control is by varying the reactivity worth of the various control mechanisms, the actual value of reactivity or of reactivity error is not computed in order to achieve reactor control.



6.3 POWER ERROR CALCULATION

- (1) The bulk power error is a measure of the difference between the measured power and the demanded power of the reactor, plus a rate of change of power error term.

$$\text{POWER ERROR} = K1(\text{ACTUAL POWER} - \text{DEMANDED POWER}) + K2(\text{ACTUAL RATE} - \text{DEMANDED RATE})$$

where the unit of Power Error is %FP, K1 is the proportional gain constant and K2 the derivative gain constant.

This relationship has a fundamental role in RRS determining the movements of reactivity devices.

- (2) The sign of the power error determines whether to
- (a) increase or decrease the levels of the zones
 - (b) remove or insert adjuster rods
 - (c) remove or insert the mechanical control absorbers.
- (3) When the power error is zero, no movement of devices will be ordered, although device movements ordered before the power error became zero will be completed.
- (4) Note that a reactivity balance is not computed for the purpose of reactor control.

6.4 SETBACK ROUTINE

- (1) The setback routine reduces reactor power promptly in a RAMP fashion if any parameter exceeds specified operating limits. These conditions are designed to protect the fuel from overheating, to protect the various reactor structures, to protect the turbine, and to protect against any loss of heat sink. In each case the Setback is activated to ensure that the reactor is controlled to safe power levels and that the fuel is cooled at all times.
- (2) The rate at which reactor power is reduced and the power level at which the setback ends are specified for each Setback condition..
- (3) The setback overrides other reactor power demands and is accompanied by alarm window annunciation.

Setback Conditions	Setback Rate (percent per second)	End Point (percent of Full Power)
Zone Control System Failure	0.2	60
Spatial Control Off Normal	0.1	-
Zone power > 110 % at full power	-	60
Flux tilt >20 % above 60 % full power	-	20
Flux tilt >40 % between 20 & 40 %FP	-	20
High Local Neutron Flux	0.1	60
High Steam Generator Pressure	0.5	10
Low Deaerator Level	0.8	2
High Moderator Level	0.8	2
Turbine Trip or Loss of Line	0.8	60
End Shield Flow	0.8	2
End Shield Temperature	0.8	2
Sustained Low Condenser Hot Well Level	0.8	2
Manual	0.5	2

- (4) Unit control mode will be placed in ALTERNATE mode whenever SETBACK is activated.



6.4 SETBACK ROUTINE

- (1) The setback routine reduces reactor power promptly in a RAMP fashion if any parameter exceeds specified operating limits - designed to protect fuel from overheating, reactor structures, turbine and against loss of heat sink.
- (2) The rate at which reactor power is reduced and the power level at which the Setback ends is specified for each Setback Condition.
- (3) The Setback overrides other reactor power demands and is accompanied by alarm window annunciation.
- (4) Unit control mode will be placed in ALTERNATE mode whenever SETBACK is activated.

Setback Conditions	Setback Rate (percent per second)	End Point (percent of Full Power)
Zone Control System Failure	0.2	60
Spatial Control Off Normal	0.1	-
Zone power > 110 % at full power	-	60
Flux tilt >20 % above 60 % full power	-	20
Flux tilt >40 % between 20 & 40 %FP	-	20
High Local Neutron Flux	0.1	60
High Steam Generator Pressure	0.5	10
Low Deaerator Level	0.8	2
High Moderator Level	0.8	2
Turbine Trip or Loss of Line	0.8	60
Endshield Flow	0.8	2
Endshield Temperature	0.8	2
Sustained Low Condenser Hot Well Level	0.8	2
Manual	0.5	2



6.5 STEPBACK ROUTINE

- (1) The Stepback Routine monitors a number of plant parameters and reduces reactor power in a STEP fashion by dropping the mechanical control absorbers either fully or partly into the reactor. In principal, the actions of the Stepback function are designed to avoid a reactor trip. However, if a reactor trip does occur, the Stepback function is activated, so that all the control absorbers will be dropped into the core, thereby aiding the rapid shutdown of the reactor.
- (2) Unit control mode will be placed in ALTERNATE mode whenever STEPBACK is activated.

Stepback Conditions	Control Absorber Response
Reactor Trip 2/3 contacts on SDS1 or SDS2	Full rod drop
All Heat Transport Pumps Trip	Full rod drop
Single pump trip	Full rod drop
Trip of two pumps at same end of reactor	Full rod drop
Heat Transport High Reactor Outlet Header	Full rod drop
Pressure & Reactor Power > 1 %FP	
High Zone Power	Full rod drop
High Rate of Log Neutron Power	Full rod drop
Low Moderator Level	Full rod drop
Low Steam Generator Level	Full rod drop



6.5 STEPBACK ROUTINE

- (1) The stepback routine monitors a number of plant parameters and reduces reactor power in a STEP fashion by dropping the mechanical control absorbers either fully or partly into the reactor - the action is designed to avoid reactor trip.
- (2) Unit control mode will be placed in ALTERNATE mode whenever STEPBACK is activated.

StepbackConditions	Control Absorber Response
Reactor Trip 2/3 contacts on SDS1 or SDS2	Full rod drop
All Heat Transport Pumps Trip	Full rod drop
Single pump trip	Full rod drop
Trip of two pumps at same end of reactor	Full rod drop
Heat Transport High Reactor Outlet Header Pressure & Reactor Power > 1 %FP	Full rod drop
High Zone Power	Full rod drop
High Rate of Log Neutron Power	Full rod drop
Low Moderator Level	Full rod drop
Low Steam Generator Level	Full rod drop

7. REACTIVITY DEVICE CONTROL

The method of reactivity device control in CANDUs can be illustrated by the diagram shown on this and subsequent pages. It shows power error in %FP on the horizontal axis and average zone level on the vertical axis.

Inside the region shown in blue, that is for power errors between -4 and $+3\%$ FP and average liquid zone levels between 15 and 80%, reactor power control is achieved by the actions of the liquid zone control system. Outside this region, as we will see, the actions of the liquid zones are supplemented by adjuster and control absorber rod movements.

- (1) Let us remind ourselves of the reactivity control devices available to the Reactor Regulating System. The primary method of short-term reactivity control is by varying the liquid level in the zone controllers. As illustrated in the diagram, under normal operating conditions the adjusters, shown in maroon, are fully inserted, the control absorbers, coloured green, are fully withdrawn and the average liquid zone control compartment level, in blue, is around 50%. If the zones are unable to provide the required reactivity effect, other devices are operated by the reactor regulating system.
- (2) A shortage of negative reactivity will be indicated by either
 - (a) a high zone controller level, that is the average zone level is above 80% full, or
 - (b) a positive power error. Remember that this is the effective power error, that is, it includes both the proportional and the derivative terms;
 - (c) both cases indicate insufficient negative reactivity, and will cause the mechanical control absorbers to be driven into the core, one bank at a time; if any adjusters are not fully in the core, they too will be inserted.
- (3) A shortage of positive reactivity will be indicated by either
 - (a) a low zone controller level, that is the average zone level is below 15%, or
 - (b) a negative power error. You should be noticing that there is an area of overlap between the regions of low zone level and negative power error, as there was in the case of high; zone level and positive power error.
 - (c) Both cases of low zone levels and negative power error will result in the adjusters to be driven out of the core in a predefined sequence, and if any absorbers are not fully out of the core, they too will be driven out.

In the next two sections we take a closer look at the logic that drives adjuster and control absorber rods.

7. REACTIVITY DEVICE CONTROL

- ▶ (1) The primary method of short-term reactivity control is by varying the liquid level in the zone controllers. Normally, the adjusters are fully inserted, the control absorbers are fully withdrawn and the average liquid zone control compartment level is between 30% & 50%. If the zones are unable to provide the required reactivity effect, other devices are operated by the reactor regulating system.
- ▶ (2) A shortage of negative reactivity will be indicated by either
 - ▶ (a) a high zone controller level, or
 - ▶ (b) a positive power error;
 - ▶ (c) both cases will cause the mechanical control absorbers to be driven in, one bank at a time (if any adjusters are not fully in the core, they too will be inserted).
- ▶ (3) A shortage of positive reactivity will be indicated by either
 - ▶ (a) a low zone controller level, or
 - ▶ (b) a negative power error;
 - ▶ (c) both cases will result in the adjusters to be driven out in a predefined sequence (if any absorbers are not fully out of the core, they too will be driven out).

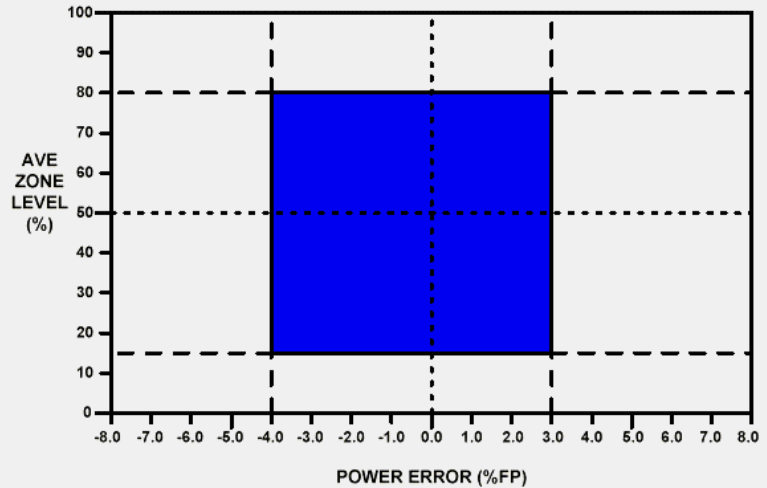

7.1 ADJUSTER RODS

As we have seen, the Adjuster rods are normally fully inserted into the core, so as to flatten the neutron flux and to provide a reserve of positive reactivity when the range of control of the liquid zones has been used up, that is they have reached their low level limit, and in particular as a reserve of positive reactivity, approximately 17 mk, to override xenon transients following certain power level reductions.

- (1) The diagram illustrates the control logic that determines when the adjuster rods are driven into the core, when they are driven out of the core, and when they are not being moved by RRS. In all cases, the movement of the adjuster rods is designed to return the operating point, that is the intersection of power error and average zone level, to the central region, shown in maroon colour on this diagram.
- (2) Auto out-drive is initiated by RRS for average zone levels below 15% AND for power errors less than 4%FP; also for all liquid zone levels when the power error is less than -4%FP, with a second bank being drive out if the power error falls below -6%FP. Note that I am using AND in capital letters as the logical operator.
- (3) Auto in-drive is initiated by RRS for average zone levels above 75% AND for power errors that are more than -4%FP; also for all liquid zone levels when the power error is greater than 4%FP.
- (4) If the operating point is within the normal range of control for the liquid zones, RRS will not initiate adjuster drive movement, but it is good operating practice not to leave rods partially in the core. It is important to remember that for the operation of the CANDU Simulator, the maximum reactor power that is allowed without the risk of fuel damage, is reduced by 5% for each bank of adjuster rods that are not fully inserted into the core. Since there are eight banks of rods, with all of them fully or at least partially withdrawn, maximum power should be limited to 60%FP. This restriction is not part of the Reactor Regulating System, nor will there be any indications of problems by the simulation, but should be observed by you at all times as you operate the Simulator as a matter of good operating practice.

7.1 ADJUSTER RODS

The Adjuster rods are normally fully inserted into the core, resulting in a flattening of the flux and providing a reserve of positive reactivity when the range of control of the liquid zones has been used up (reached the low level limit), and in particular as a reserve of positive reactivity (approximately 17 mk) to override xenon transients following certain power level reductions.

- ▶ (1) The diagram illustrates the control logic that determines when the adjuster rods are driven into the core, when driven out of the core, and when they are not being moved by RRS.
- ▶ (2) Auto Out-drive is initiated by RRS for average zone levels below 15% AND the power error is less than 4%FP; also for all liquid zone levels when the power error is less than -4%FP, with a second bank being driven out if the power error falls below -6%FP.
- ▶ (3) Auto In-drive is initiated by RRS for average zone levels above 75% AND the power error is more than -4%FP; also for all liquid zone levels when the power error is greater than 4%FP.
- ▶ (4) If the operating point is within the normal range of control for the liquid zones, RRS will not initiate adjuster drive movement, but it is good operating practice not to leave rods partially in the core.

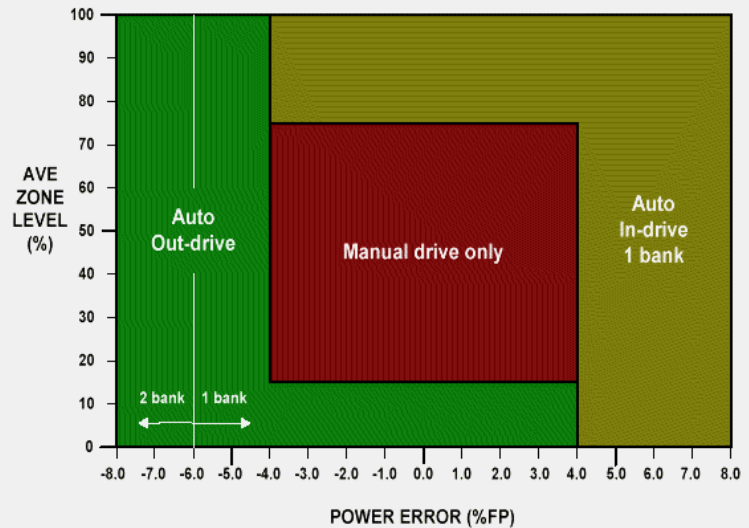

7.2 CONTROL ABSORBER RODS

You will recall that the usual position of the Control Absorber rods is completely outside the core. They are driven into the core to provide negative reactivity when the liquid zones have used up their range of control, that is they have reached their high level limit. The control absorbers can also be dropped into the core fully or part way by the Stepback program. The total reactivity worth of the four control absorbers is about 9 mk.

- (1) The diagram illustrates the control logic that determines when the control absorber rods are driven into the core, when driven out of the core, and when they are not being moved by RRS.
- (2) Auto In-drive is initiated by RRS for average zone levels above 80% AND the power error greater than $-4\%FP$; also for all liquid zone levels when the power error is greater than $3\%FP$, with a second bank being driven in if the power error is above $5\%FP$.
- (3) Auto Out-drive is initiated by RRS for average zone levels below 75% AND the power error is less than $3\%FP$; also for all liquid zone levels when the power error is less than $-4\%FP$, with a second bank being driven out if the power error falls below $-5\%FP$.
- (4) Absorber drive is stopped if the average zone level is between 75% and 80% AND the power error is between $-4\%FP$ and $3\%FP$.

7.2 CONTROL ABSORBER RODS

The usual position of the Control Absorber rods is completely outside the core. They are driven into the core to provide negative reactivity when the liquid zones have used up their range of control (reached the high level limit). The control absorbers can also be dropped into the core fully or part way by the Stepback program. The total reactivity worth of the four control absorbers is about 9 mk.

- ▶ (1) The diagram illustrates the control logic that determines when the control absorber rods are driven into the core, when driven out of the core, and when they are not being moved by RRS.
- ▶ (2) Auto In-drive is initiated by RRS for average zone levels above 80% AND the power error greater than -4%FP; also for all liquid zone levels when the power error is greater than 3%FP, with a second bank being driven in if the power error is above 5%FP.
- ▶ (3) Auto Out-drive is initiated by RRS for average zone levels below 75% AND the power error is less than 3%FP; also for all liquid zone levels when the power error is less than -4%FP, with a second bank being driven out if the power error falls below -5%FP.
- ▶ (4) Absorber drive is stopped if the average zone level is between 75% and 80% AND the power error is between -4%FP and 3%FP.

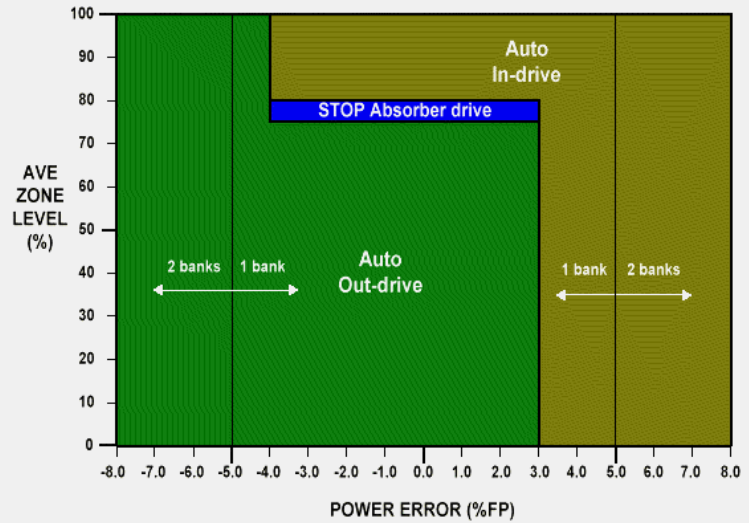

7.3 SHUTDOWN ROD WITHDRAWAL LOGIC

Although the Shutdown Rods are part of Reactor Shutdown System #1, and as such are to be fully independent of the Reactor Regulating System, the latter is used for the purpose of withdrawing the Shutdown Rods. Independence is maintained by separating the motor that drives out the shutdown rods under the control of RRS by a clutch from the shaft of the rod withdrawing mechanism by a clutch, which is entirely under the control of SDS#1.

The reason for using RRS to withdraw the Shutdown Rods is to ensure that reactor power control is maintained during Shutdown Rod withdrawal, and that under no circumstance will the withdrawal of the Shutdown Rods result in the insertion of excessive amounts of reactivity.

The following are the factors that need to be understood and remembered for the withdrawal logic of the Shutdown Rods:

- (1) Dropping of the shutdown rods is controlled by Shutdown System #1.
- (2) Withdrawal of the rods is controlled by the Reactor Regulating System.
- (3) Withdrawal is inhibited until the reactor trip signal is cleared and SDS#1 is 'RESET'.
- (4) For withdrawal, the Shutdown Rods are arranged in two banks, and the withdrawal is stopped if the power error or the rate log power change exceed specified limits.
- (5) Manual withdrawal is allowed only if computer control is unavailable. The operator may also select individual rods to be driven in or out under manual control, provided the prescribed unit operating procedures are being followed.



7.3 SHUTDOWN ROD WITHDRAWAL LOGIC

Although the Shutdown Rods are part of Reactor Shutdown System #1, and as such are to be fully independent of the Reactor Regulating System, the latter is used for the purpose of withdrawing the Shutdown Rods. As explained in Module 2B, the independence is maintained by separating the motor that drives out the shutdown rods under the control of RRS by a clutch from the shaft of the rod withdrawing mechanism by a clutch, which is entirely under the control of SDS#1.

The reason for using RRS to withdraw the Shutdown Rods is to ensure that reactor power control is maintained during Shutdown Rod withdrawal, and that under no circumstance will the withdrawal of the Shutdown Rods result in the insertion of excessive amounts of reactivity.

The following are the factors that need to be understood and remembered for the withdrawal logic of the Shutdown Rods:

- (1) Dropping of the Shutdown Rods is controlled by Shutdown System #1.
- (2) Withdrawal of the rods is controlled by the Reactor Regulating System.
- (3) Withdrawal is inhibited until the reactor trip signal is cleared and SDS#1 is 'RESET'.
- (4) For withdrawal, the Shutdown Rods are arranged in two banks, and the withdrawal is stopped if the power error or the rate log power change exceed specified limits.
- (5) Manual withdrawal is allowed only if computer control is unavailable. The operator may also select individual rods to be driven in or out under manual control, provided the prescribed unit operating procedures are being followed.

8. REGULATING SYSTEM BLOCK DIAGRAM

The diagram shows all the key components of the Reactor Regulating System that we have discussed in this Session. It is in the form of a feedback control loop, showing the processes being controlled, the parameters measured, the control algorithms and the final control elements.

The process measurements are taken from the Reactor, including neutronic and thermal power measurements, and from the Steam Generator. These two process blocks have been highlighted in a blue coloured frame.

The readings of the Vanadium Flux detectors are input to the Flux Mapping Program, the ion chamber and Platinum clad Inconel flux detector signals, along with coolant flow and temperature readings, feedwater flow and temperature, steam flow and pressure are all input to the Power Measurement and Calibration program. The blocks responsible for Reactor Power Control in RRS are enclosed by a red frame. Additional programs to implement Reactor Power Control are Demanded Power Routine, which receives the Reactor Power Setpoint for the given mode of operation, including Reactor Setback, compares it with the Actual Reactor Power value and computes the effective power error. Based on the sign and magnitude of the power error the Reactivity Device Controls program determines what signals to send to each of the reactivity control devices. In the case that a Reactor Stepback condition is detected, signal is sent to open the clutches holding the Mechanical Control Absorbers.

All the signals to the Reactivity Devices are connected via Hardware Interlocks, these two blocks being highlighted in orange frames. The change in position of the Reactivity Mechanisms, plus any Liquid Poison that may be manually added, will alter the reactivity and hence the neutron and thermal power of the core, thereby closing the control loop.

15. REGULATING SYSTEM BLOCK DIAGRAM

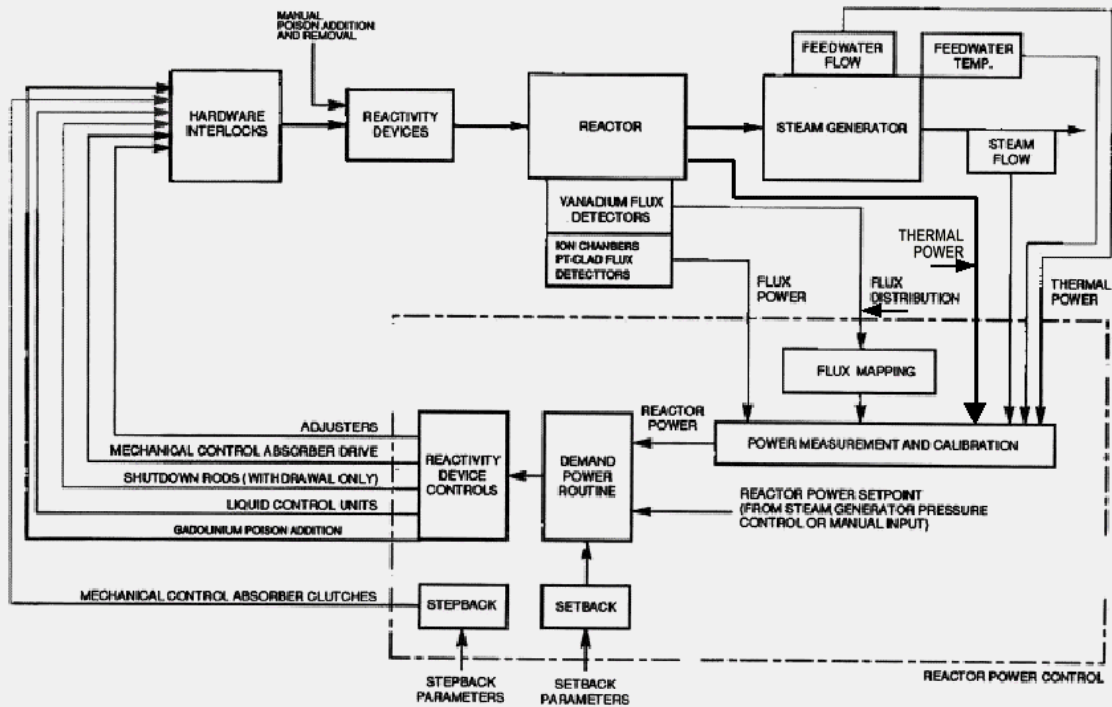

RRS OVERVIEW

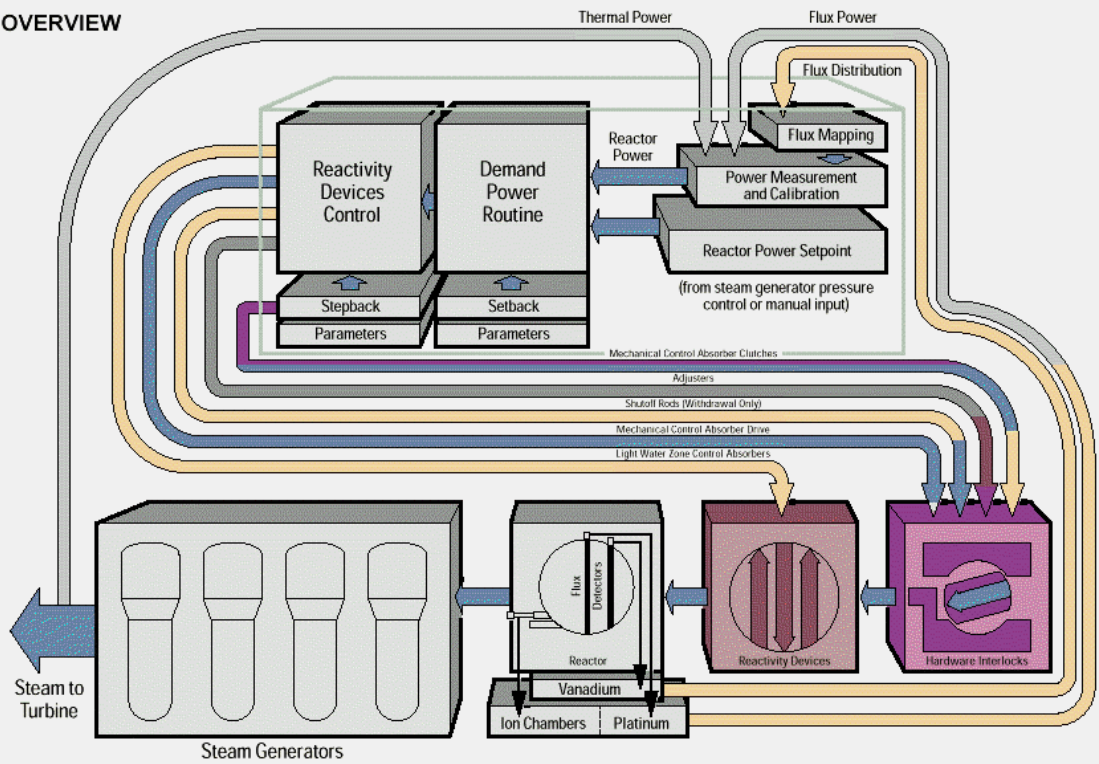

SESSION 3:

MODULE CONTENTS

1.	INTRODUCTION	page 2
2.	THE HEAT TRANSPORT SYSTEM	page 3
3.	MAIN CIRCUIT EQUIPMENT	page 4
4.	MAIN CIRCUIT FLOWS AND PRESSURES	page 5
5.	PRESSURE AND INVENTORY CONTROL	page 6
6.	PRESSURIZER - NORMAL MODE	page 7
7.	BLEED CONDENSER	page 8
8.	PRESSURE CONTROL BY FEED AND BLEED – SOLID MODE	page 9
9.	INVENTORY CONTROL	page 10
10.	STORAGE AND CHEMICAL CONTROL	page 11
11.	HEAT TRANSPORT OVER-PRESSURE PROTECTION	page 12
12.	CANDU 9 PRESSURE AND INVENTORY CONTROL SYSTEM	page 13

1. INTRODUCTION

This Session deals with the Heat Transport System, including the Main Circuit, the Pressure and Inventory Control Systems. The principal purpose of the Heat Transport System is to cool the fuel at all times, and it also forms one of the barriers designed to ensure that the radioactivity in the fuel is not released to the environment.

The diagram shows the key components of the Main Circuit, namely:

- (1) Pressure Tubes
- (2) Feeder Pipes
- (3) Reactor Inlet and Outlet Headers
- (4) Steam Generators
- (5) Circulating Pumps
- (6) Interconnecting Piping



1. INTRODUCTION

This Session deals with the Heat Transport System, including the Main Circuit, the Pressure and Inventory Control Systems. The principal purpose of the Heat Transport System is to cool the fuel at all times, and it also forms one of the barriers designed to ensure that the radioactivity in the fuel is not released to the environment.

The diagram shows the key components of the Main Circuit, namely:

- (1) Pressure Tubes
- (2) Feeder Pipes
- (3) Reactor Inlet and Outlet Headers
- (4) Steam Generators
- (5) Circulating Pumps
- (6) Interconnecting Piping

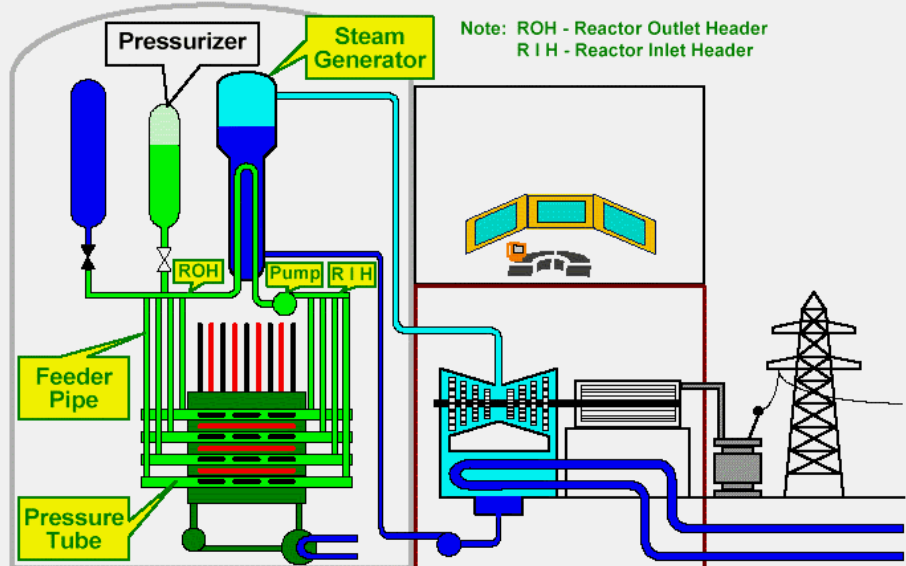

2. THE HEAT TRANSPORT SYSTEM

The Heat Transport System, which is often called the Primary Heat Transport or PHT system, has many sub-systems. On the diagram the following four systems are shown: the Main Circuit, the Pressure and Inventory Control System, the Shutdown Cooling System and the Purification System.

- (1) The diagram shows one of the two loops of the Main Circuit. Starting from the upper fuel channel and following the direction of coolant flow, we see that the pressure tube is connected via a feeder pipe to one of the Reactor Outlet Headers, from there to the Steam Generator, the coolant next passes through the thousands of inverted “U” tubes and transfers its heat to the light water on the secondary side, then the flow is directed to the inlet of one of the circulating pumps, after the pumps the coolant flows to the Reactor Inlet Header, and finally via a feeder pipe to the next pressure tube, where it flows through the reactor in a direction opposite to the adjacent pressure tube, then completes a similar path through the second Reactor Outlet Header, Steam Generator, Reactor Inlet Header, and back to the original fuel channel. There are 120 such fuel channel pairs connected in parallel between the Reactor Inlet and Outlet Headers in each of the two loops, making up the total of 480 fuel channels in the Heat Transport System of a CANDU 9 reactor. All this equipment in the Main Circuit is designed to achieve the following functions:
 - (a) transport the heat produced by the fission of natural uranium fuel in the pressure tubes to the steam generators, where the heat is transferred to light water to produce steam;
 - (b) provide cooling of the reactor fuel at all times during reactor operation and provide for the heavy water coolant to remove decay heat when the reactor is shut down;
 - (c) each heat transport pump has sufficient rotational inertia so that the rate of coolant flow reduction matches the rate of power reduction following a reactor trip if power to the pump motor is lost, and the system design allows decay heat removal by natural circulation in case of a total loss of pumping power;
 - (d) limit the effect of postulated loss-of-coolant accidents to within the capability of the safety systems and provide a path for emergency coolant flow to the reactor fuel in the event of such an accident;
 - (e) provide containment for fission products that may be released from defected fuel during normal operating conditions.
- (2) The Pressure and Inventory Control System maintains the required pressure of the heavy water coolant in the main circuit using the Pressurizer, provides make-up water to the main circuit via the Feed Pumps, and holds the excess inventory for the system in the D2O Storage Tank. It also provides over-pressure relief and degassing of the coolant via the Bleed Condenser, and it cools the heavy water to allow its purification and storage.

The diagram highlights the system with a red coloured frame and the labels of the main pieces of equipment. Note that the bottom of the Pressurizer is connected to one of the Reactor Outlet Headers, and its top to the Bleed Condenser. Note also that there is a flow from the Reactor Inlet Header to the Bleed Condenser, and an outflow from the bottom of the Bleed Condenser to the HT Purification system. The functions of the D2O Storage Tank and the Pumps highlighted on the diagram will be discussed further in Section 10.

2. THE HEAT TRANSPORT SYSTEM

The (Primary) Heat Transport System consists of the following sub-systems:

- ▶ (1) The Main Circuit:
 - (a) transports the heat produced by the reactor to the steam generators;
 - (b) provides cooling of the reactor fuel at all times;
 - (c) allows decay heat removal by natural circulation under total loss of pumping power;
 - (d) provides a path for emergency coolant flow in case of loss of coolant accidents;
 - (e) provides containment for fission products that may be released from defected fuel
- ▶ (2) The Pressure and Inventory Control System: maintains the required pressure in the main circuit and provides make-up water to and holds the excess inventory for the system.
- ▶ (3) The Shutdown Cooling System: removes reactor decay heat following shutdown.
- ▶ (4) The Purification System: controls the chemistry of the reactor coolant.

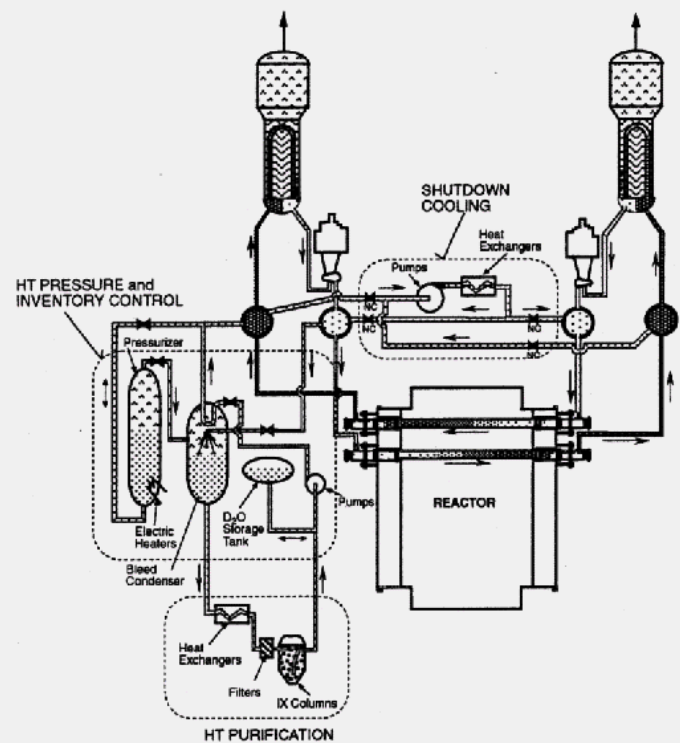

- (3) The Shutdown Cooling System cools the heat transport heavy water below the 177°C limit possible with the steam generators, and has the capability to indefinitely remove reactor decay heat following shutdown.

The diagram highlights the system with a red coloured frame and the labels of the main pieces of equipment. The flow of heavy water is taken from the Reactor Outlet Headers through the Shutdown Cooling Pumps and the Shutdown Cooling Heat Exchangers, and returned to the Main Circuit at the Reactor Inlet Headers.

- (4) The Purification System limits the accumulation of corrosion products and other fine solids in the coolant, and controls the chemistry of the reactor coolant, so that the pD value is maintained at the required level.

The diagram highlights the system with a red coloured frame and the labels of the main pieces of equipment. The flow of heavy water is taken from the bottom of the Bleed Condenser, it passes through a Heat Exchanger, Filter and Ion Exchange columns. The cooled and purified heavy water goes either into the D₂O Storage Tank, or its pressure is raised by the Pressurizing Pumps, which are also called the Feed Pumps, its temperature is raised by heat exchange in the Bleed Condenser, and is then returned to the Main Circuit.

3. MAIN CIRCUIT EQUIPMENT

The illustration is a three dimensional computer representation of the main heat transport circuit equipment. The four steam generators are shown in blue, and adjacent to each is one of the main circulating pumps and its motor, in green colour. The Reactor Inlet and Outlet Headers are in yellow, and these are connected to the pressure tubes by the hundreds of feeder pipes, shown as thin green vertical lines that connect at various angles to the pressure tubes. The calandria is purple coloured, as are the horizontal flux detectors and poison injection assemblies, while the vertical flux detector and reactivity mechanisms are in green, going from the top of the calandria to the orange coloured reactivity mechanism platform. Please make certain that you are able to find all these system components on the diagram.

- (1) The schematic diagram of the Main Circuit shows the two cross-connected figure-of-eight loops. I labeled the upper circuit as Loop 1, and the lower circuit as Loop 2, and indicated the interconnection between the two loops. As we saw in the previous section, each loop consists of 240 pressure tubes each with an inlet and an outlet feeder pipe, although the diagram only shows two of the pressure tubes. The two loops are interconnected at their respective reactor outlet headers.

If you place the cursor over the words feeder pipes in blue letters, you will see a photograph of the face of a CANDU reactor. The Fuel Channels terminating in the End Fittings, and the Feeder Pipes connected to the End Fittings can be seen.

By selecting the successive action arrows, you can see the highlights I put on the diagram for each of the following Items. At Item(2) are the reactor inlet headers, Item (3) shows the reactor outlet headers, Item (4) the main circulating pumps that are driven by electric motors, and Item (5) the steam generators.

Various pipes that connect the above components to one another complete the Main Circuit. Note that there are no valves in either of the main loops, so it is not possible in a CANDU 9 heat transport main circuit to isolate any part of a given loop, or one loop from the other. There are valves that connect the main circuit to the pressure and inventory control system, as we will see later in this Session.

▶▶ 3. MAIN CIRCUIT EQUIPMENT

The Main Heat Transport circuit consists of:

- ▶▶ (1) Two cross-connected figure-of-eight loops, having 480 pressure tubes, each with individual inlet and outlet **feeder pipes**.
- ▶▶ (2) Four reactor inlet headers.
- ▶▶ (3) Two reactor outlet headers.
- ▶▶ (4) Four motor driven pumps.
- ▶▶ (5) Four steam generators.
- (6) Interconnecting piping and valve connections to the pressure and inventory control system.

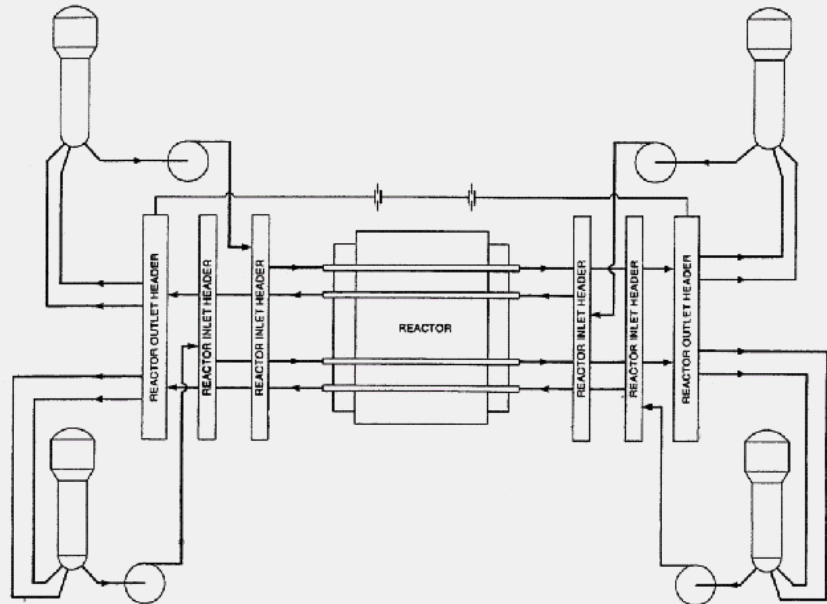

4. MAIN CIRCUIT FLOWS AND PRESSURES

The diagram shows the direction of coolant flow around the main circuit, the feed flow into, and the bleed flow out of the main circuit. The pressures around the loop are also shown. The CANDU 9 heat transport pressure control system is designed to maintain the reactor outlet header pressure at 10 Mega Pascals. Under normal operating conditions the Pressurizer achieves this pressure control.

There is a pressure drop of 1.8 Mega Pascals around half the loop due to fluid friction, principally across the steam generator and the pressure tubes. Each circulating pump raises the coolant pressure to compensate for the pressure drop. Most of the power driving the pump motor appears as heat added to the coolant, approximately 11 Megawatts for a CANDU 9 circulating pump.

There is a small amount heavy water that is normally removed from the main circuit, called the bleed flow, for the purpose of purification and chemical control. This flow is taken from the pump outlet, the point of highest pressure in the circuit. There is an amount of feed that is supplied to the main circuit to maintain the heavy water coolant inventory, this flow is to the inlet of the circulating pump, which is the point of lowest pressure in the main circuit.

The key design requirements for the main circuit flow and pressure are to ensure that the fuel is cooled at all times. In particular:

- (1) The main circuit pressure must be maintained so that there is adequate saturation margin in the reactor outlet headers, and that the required net positive suction head for the circulation pumps is provided.
- (2) There must be at all times continuous flow to provide cooling of the fuel.
- (3) The main circuit must be filled with heavy water, except under specific shutdown conditions.



4. MAIN CIRCUIT FLOWS AND PRESSURES

- (1) The main circuit pressure must be maintained so that there is adequate saturation margin in the reactor outlet headers, and that the required net positive suction head for the circulation pumps is provided.
- (2) There must be at all times continuous flow to provide cooling of the fuel.
- (3) The main circuit must be filled with heavy water, except under specific shutdown conditions.

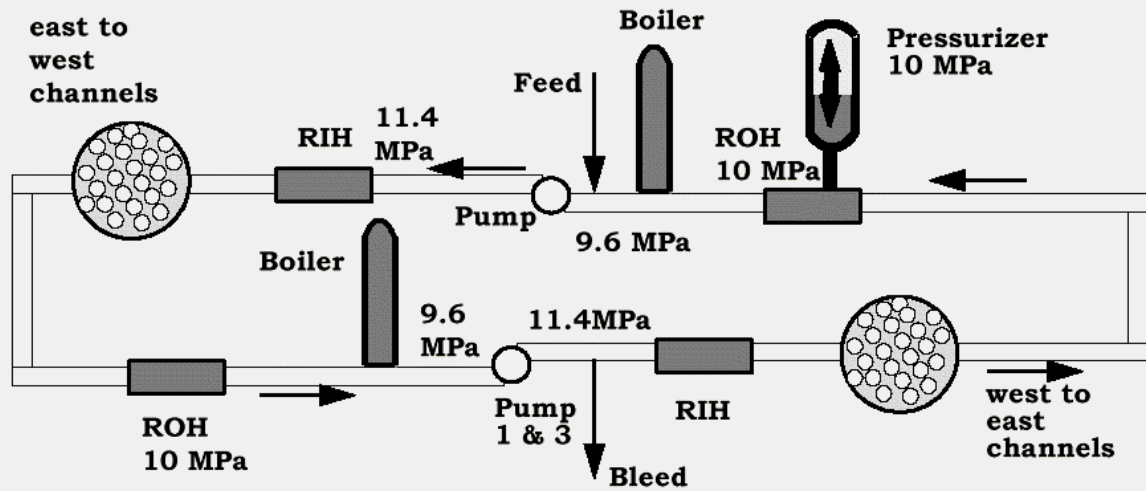

5. PRESSURE AND INVENTORY CONTROL

The diagram highlights the main features of the Heat Transport Pressure and Inventory Control System. The purpose of this system is to maintain the pressure of the Main Circuit at the specified setpoint, and the corresponding mass of heavy water in the Main Circuit. In this context the word “inventory” means the amount of heavy water mass. Under normal operating conditions the Pressurizer keeps the Main Circuit Pressure at its setpoint of 10 MPa, and also accommodates changes in inventory via Pressurizer level control. This is called the “Normal Mode” of pressure control, but it does not relate to Normal Mode of Unit control. If the Pressurizer has to be isolated from the Main Circuit, then the feed and bleed system will control both pressure and inventory, and pressure control is said to be in “Solid Mode”.

The key equipment and control systems are highlighted on the diagram. You should make sure that you can identify each of these and the relevant interconnections on the diagram.

The Pressurizer is connected to the reactor outlet header via the pressurizer isolation valve, and to the Bleed Condenser through the steam bleed valve. The outflow from the Bleed Condenser goes to the Storage Tank through the Bleed Condenser Level Control valve, and the Feed Pump supplies feed flow to the Main Heat Transport Circuit. Bleed flow from the Main Circuit goes to the Bleed Condenser.

The Pressurizer and the Bleed Condenser each have a Pressure Control System and a Level Control System. The Inventory of heavy water in the main circuit is controlled by a system of Feed and Bleed, and under normal operating conditions there is a small flow of Main Circuit heavy water through the Purification system.



5. PRESSURE AND INVENTORY CONTROL

The diagram highlights the main features of the Heat Transport Pressure and Inventory Control System. Under normal operating conditions the Pressurizer keeps the Main Circuit Pressure at its setpoint of 10 MPa, and also accommodates changes in inventory via Pressurizer level control. If the Pressurizer has to be isolated from the Main Circuit, then the feed and bleed system will control both pressure and inventory, and pressure control is said to be in "Solid Mode".

The key equipment and control systems are:

- (1) Pressurizer
- (2) Bleed Condenser
- (3) Storage Tank
- (4) Feed Pumps
- (5) Pressurizer Pressure Control
- (6) Pressurizer Level Control
- (7) Bleed Condenser Pressure Control
- (8) Bleed Condenser Level Control
- (9) Feed, Bleed and Purification

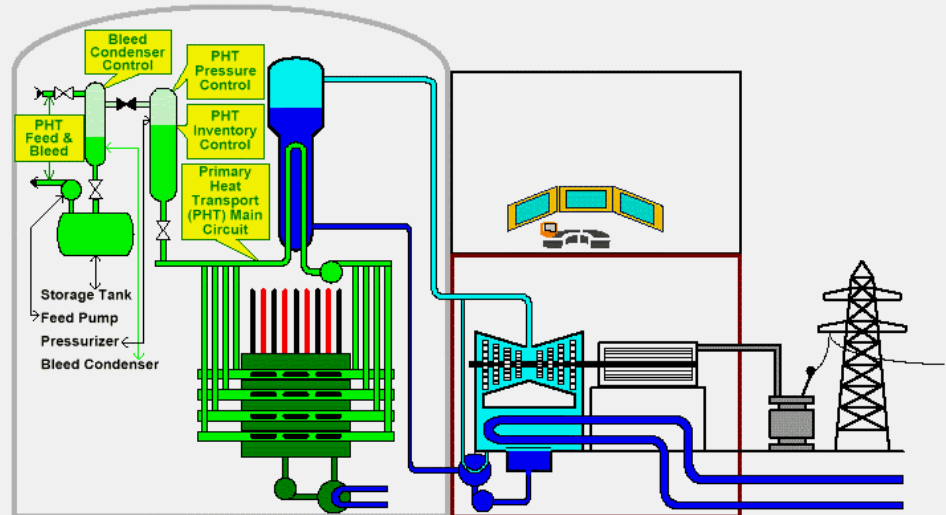

6. PRESSURIZER – NORMAL MODE

The Pressurizer is designed to control the pressure and the inventory of heavy water in the Main Circuit for all normal operating conditions. This section describes how the Pressurizer Pressure is controlled, and in Section 9 we will look at the role of the Pressurizer Level controller in heavy water inventory control. The Pressurizer is a large vertical cylindrical carbon steel vessel, having a volume of 130 cubic metres.

- (1) The Pressurizer is connected to the Main Heat Transport System at one of the Reactor Outlet Headers by the pressurizer connection line, as indicated by arrow (a). The Pressurizer Isolation Valve, at arrow (b), is a remotely controlled motorized valve, and is fully open under normal operating conditions. This allows the free flow of heavy water between the Pressurizer and the Main Circuit, in response to changes in the differences between the Main Circuit and Pressurizer pressures until they are equalized. The valve is closed to isolate the Pressurizer from the Main Heat Transport Circuit during maintenance shutdowns.
- (2) The Pressurizer's liquid and steam are kept at saturation, and at a pressure that is slightly lower than the saturation conditions in the reactor outlet header at 100%FP. For CANDU 9 the Reactor Outlet Header setpoint is normally 10 MPa.
- (3) The pressure in the Pressurizer, and at the same time in the Main Circuit, can be raised by adding heat to the liquid via electric heaters. A variable heater is used under normal steady state conditions. ON-OFF heaters are turned ON if the pressure drops below the range of the variable heater. There are a total of six heaters in a CANDU 9 Pressurizer, normally one is variable and the other five operate in ON-OFF mode. The total capacity of the six heaters is 2.1 Megawatts.
- (4) The pressure in the Pressurizer, and therefore in the Main Circuit, can be reduced by bleeding steam out of the pressurizer. If the pressure increases beyond the range of the pressurizer pressure control valves, two steam relief valves discharge additional steam to the Bleed Condenser until the pressure is reduced to the normal control range. To achieve cooldown of the pressurizer, cool heavy water can be sprayed into the steam space to condense some of the steam.
- (5) During a reactor power increase the Reactor Outlet Header pressure rises as a result of the swell in the system. The level setpoint in the pressurizer is increased automatically so that all the swell resulting from power increases is stored in the pressurizer. The opposite takes place on a reactor power decrease.
- (6) The level in the pressurizer, and therefore the heat transport system inventory, is normally controlled via the main circuit feed and bleed valves. A pressurizer level below the setpoint indicates that there is insufficient heavy water inventory in the Main Circuit, so some additional amount is fed into the Main Circuit from the D2O Storage Tank, until the level in the Pressurizer reaches the setpoint. A Pressurizer level above the setpoint is an indication of excess heavy water inventory in the Main Loop, and the bleed flow is increased, along with decreasing the feed flow if there is any, until the level error is eliminated. We will take a more detailed look in Section 6 at how the Main Circuit coolant inventory is controlled by the feed and bleed system via the pressurizer level controller.

6. PRESSURIZER - NORMAL MODE PRESSURE CONTROL

- ▶ (1) The Pressurizer is connected to the Main Heat Transport System at one of the Reactor Outlet Headers by the pressurizer connection line. A motorized valve is provided to isolate the pressurizer from the heat transport system during maintenance shutdowns.
- ▶ (2) The Pressurizer's liquid and steam are kept at saturation, and at a pressure that is slightly higher than the saturation conditions in the reactor outlet header at 100%FP.
- ▶ (3) Pressurizer (and hence heat transport) pressure can be raised by adding heat to the liquid via electric heaters. A variable heater is used under normal steady state conditions. ON-Off heaters are turned On if the pressure drops below the range of the variable heater.
- ▶ (4) The pressure can be reduced by bleeding steam out of the pressurizer. If the pressure increases beyond the range of pressurizer pressure control valves, two steam relief valves discharge steam to the bleed condenser until the pressure is reduced to the normal control range. To achieve cooldown of the pressurizer, cool heavy water is sprayed into the steam space to condense some of the steam.
- ▶ (5) During a reactor power increase the outlet header pressure rises as a result of the swell in the system. The level setpoint in the pressurizer increases automatically so that all the swell resulting from power increases is stored in the pressurizer.
- ▶ (6) The level in the pressurizer, and therefore the heat transport system inventory, is normally controlled via the main circuit feed and bleed valves.

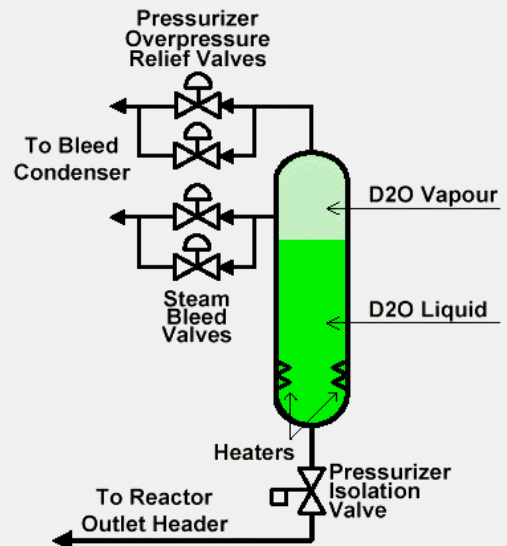

7. BLEED CONDENSER

The principal purpose of the Bleed Condenser is to reduce the pressure and temperature of the heavy water coolant that flows out of the Main Circuit and of the heavy water steam that flows out of the Pressurizer. The Bleed Condenser is designed to be part of the Primary Heat Transport System pressure boundary, and it also provides the means to “degas”, that is to allow for the removal of non-condensable gasses, mostly nitrogen, from the heat transport coolant heavy water.

Like the Pressurizer, the Bleed Condenser when operating normally contains heavy water and steam at saturation conditions, but at a much lower pressure than the Pressurizer, around 1.7 Mega Pascals. It is a vertical cylindrical carbon steel vessel, much smaller than the Pressurizer, having a volume of 25 cubic metres.

- (1) Under normal operating conditions the Bleed Condenser receives liquid bleed flow from the Main Heat Transport Circuit and steam bleed flow from the Pressurizer. In case of over-pressure conditions in the Main Circuit, the Liquid Relief (LR) valve opens until the pressure is reduced to an acceptable level. Over-pressure conditions in the Pressurizer result in additional steam flow to the Bleed Condenser through the Pressurizer over-pressure steam relief valves.
- (2) The incoming liquid bleed and relief flows expand and flash into steam and mix with any steam flow from the Pressurizer. The heavy water steam is cooled in the Bleed Condenser and its pressure is reduced by a large amount, in the order of 8 Mega Pascals. Much of the incoming steam is condensed, and although the vessel operates with heavy water at saturation, the mixture of water and steam is at a much reduced temperature and pressure.
- (3) While pressure control in the Pressurizer is achieved by either adding heat to the liquid or bleeding steam from the vessel, in the case of the Bleed Condenser its pressure is controlled by varying the amount of cool heavy water flowing in the reflux tube bundle and by spraying cool heavy water into the vapour space. The Reflux Flow is part of the feed flow going to the Main Circuit, while the Spray Flow mixes with the other inflows of heavy water in the Bleed Condenser.
- (4) The Reflux Flow and the Spray Flow are regulated by control valves (a) and (b) as demanded by the bleed condenser pressure controllers. Under normal operating conditions Bleed Condenser pressure is controlled by varying the Reflux Flow. Since the Reflux Flow is part of the Feed Flow into the Main Circuit, the respective control loops are designed to meet the requirements of both Reflux Flow for the purpose of Bleed Condenser pressure control, and Feed Flow for the purpose of Main Circuit inventory control.

If the Bleed Condenser pressure rises by a specified amount above the setpoint of the pressure controller regulating Reflux flow, additional cooling is provided by the Spray Flow. The setpoint of the Bleed Condenser pressure controller that regulates the Spray Flow is set somewhat higher than that of the Bleed Condenser pressure controller that regulates Reflux flow.

- (5) The level in the Bleed Condenser is controlled by regulating the outflow from the Bleed Condenser that goes through the Bleed Cooler to the Purification System or bypassing it to the suction of the D2O Feed Pump.

▶▶ 7. BLEED CONDENSER

- ▶▶ (1) Under normal operating conditions the bleed condenser receives liquid bleed flow from the main heat transport system and steam bleed flow from the pressurizer. In case of over-pressure conditions in the Main Circuit, the Liquid Relief (LR) valve opens until the pressure is reduced to an acceptable level.
- ▶▶ (2) By allowing the incoming liquid to expand and, along with any steam flow, be condensed, a large pressure reduction is achieved (~ 7.5 MPa).
- ▶▶ (3) Pressure in the bleed condenser is controlled by condensing the heavy water steam with cooling flow in a reflux tube bundle and a spray flow.
- ▶▶ (4) The reflux bundle flow and the spray flow are regulated by control valves as demanded by the bleed condenser pressure controllers. Normal cooling is by the reflux flow, with the flow regulated by the reflux valve to control bleed condenser pressure at its setpoint.
Under conditions of abnormally high flow into the bleed condenser, additional cooling is provided by the spray flow, controlled at a pressure setpoint somewhat above that of reflux valve.
- ▶▶ (5) The level in the bleed condenser is controlled by regulating the outflow via the bleed cooler.

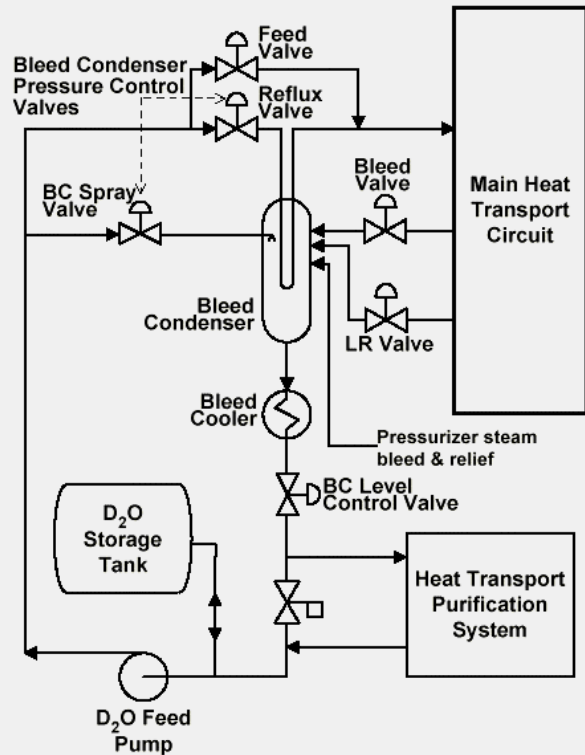

8. PRESSURE CONTROL BY FEED AND BLEED – SOLID MODE

In Section 6 we looked at how the pressure of the Main Heat Transport Circuit can be controlled by the use of a Pressurizer. It is also possible, indeed at times necessary, to be able to control the Main Circuit's pressure when the Pressurizer is isolated from the Main Circuit. This method relies on forcing additional heavy water coolant into the already full Main Circuit to raise its pressure, or releasing some of the coolant, while still keeping the circuit filled, to reduce its pressure. Adding extra coolant is a process called "feed", and removing some coolant is referred to as "bleed", so such a system of pressure control is called "feed and bleed".

- (1) In order to pressurize the heat transport system without raising its temperature, a system other than a pressurizer is needed. Some of the early CANDU heat transport systems were designed without a pressurizer, and used a system of feed and bleed to control Heat Transport Main Circuit pressure. As shown on the diagram, the bleed flow is taken from the Main Circuit and is connected to the Bleed Condenser, which is at a much lower pressure. The feed flow must be at a pressure higher than the pressure in the Main Circuit at the point where the feed enters the main loop. The high pressure is provided by the Feed Pumps and the flow of feed is through the Feed valves.
- (2) By using a source of coolant at a pressure higher than the main heat transport system, namely the D2O Feed Pumps, it is possible to raise heat transport system pressure by simply forcing more liquid into it. To reduce the pressure, some of the liquid is removed from the main circuit. Such a pressure control system is also called "solid", because it relies on the tensile strength of the vessels and piping that make up the main circuit, and on the slight but finite compressibility of water.
- (3) The Bleed flow is taken from the outlet of one of the heat transport pumps and it discharges into the bleed condenser via the bleed valves as two phase flow. The steam is condensed in the Bleed Condenser, its pressure having been reduced to about 1.7 Mega Pascals.
- (4) The Feed flow to the Main Circuit is supplied through the feed control valves and is connected to the main circuit at the circulating pump suction line. One heavy water feed pump is normally operating and takes water from the heavy water storage tank and/or the heat transport purification system. Note that part of the feed flow goes through the Bleed Condenser so that some of the heat from the bleed flow that is given up in the Bleed Condenser is recovered. Arrow (a) points to the Feed valve (actually two valves in parallel to provide redundancy), and arrow (b) points to the Reflux Valve, and it is the sum of these two flows that makes up the overall Feed flow that is supplied by the Feed Pumps, at arrow (c). We saw in Section 7 that the Reflux valve was regulated by the Bleed Condenser Pressure Controller. In the next section we will see how the Feed and Bleed valves are controlled.

8. PRESSURE CONTROL BY FEED AND BLEED - SOLID MODE

- (1) In order to pressurize the heat transport system without raising its temperature, a system other than a pressurizer is needed. Some of the early CANDU heat transport systems were designed without a pressurizer, and used a system of feed and bleed to control Heat Transport Main Circuit pressure.
- (2) By using a source of coolant at a pressure higher than the main heat transport system, it is possible to raise heat transport system pressure by simply forcing more liquid into it. To reduce the pressure, some of the liquid is removed from the main circuit. Such a pressure control system is also called "solid", because it relies on the tensile strength of the vessels and piping that make up the main circuit, and on the slight but finite compressibility of water.
- (3) Bleed flow is taken from the outlet of one of the heat transport pumps and discharged into the bleed condenser via the bleed valves as two phase flow. The steam is condensed in the bleed condenser.
- (4) The Feed flow to the Main Circuit is supplied through the feed control valves and is connected to the main circuit at the circulating pump suction line. One heavy water feedpump is normally operating and takes water from the heavy water storage tank and/or the heat transport purification system. Note that part of the feed flow goes through the Bleed Condenser so that some of the heat from the bleed flow that is given up in the Bleed Condenser is recovered.

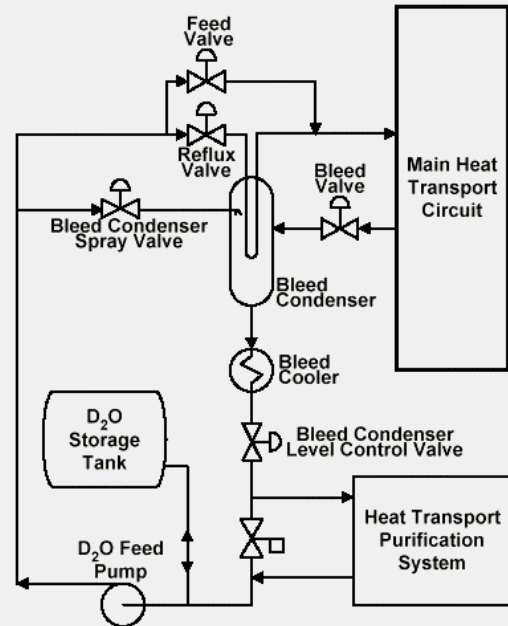

9. INVENTORY CONTROL

So far in this Session I have been discussing mostly how the pressure of the Heat Transport Main Circuit is controlled. In this section I will concentrate on Inventory control, although as you should appreciate from the previous sections, controlling the pressure of the Main Circuit also involves controlling the inventory of heavy water in the Main Circuit, and vice versa. The word “inventory” in this context means the mass of heavy water.

- (1) Inventory control for the heat transport system is achieved by feed and bleed, and is designed to compensate for volume changes as a function of coolant temperature. Inventory and Pressure Control are closely linked, since changing one will alter the other. What is very important to understand is that there are significant differences in handling inventory between “normal” and “solid” modes of pressure control.
- (2) When Heat Transport Pressure Control is in “normal mode” the Pressurizer Pressure Control system controls the pressure of the Main Circuit, while the Inventory of heavy water is controlled by the Pressurizer Level Control system. In other words, as indicated by the red lines on the diagram, the amount of feed into the Main Circuit and the amount of bleed out of the Main Circuit are controlled so that the Pressurizer level is maintained at its setpoint. Recall that the Pressurizer level setpoint changes as a function of reactor power, to match the expected shrink and swell of the coolant as a function of temperature changes. Short term inventory changes will be reflected by Pressurizer level changes, and the feed and bleed system will eliminate pressurizer level error by supplying heavy water from or storing it in the D2O Storage tank.
- (3) When the Pressurizer is isolated from the main circuit, typically under warm-up and cool-down conditions, it can play no role in either pressure or inventory control. Under these conditions, both heat transport pressure and inventory control are performed simultaneously by the feed and bleed circuit. This condition is referred to as the “solid mode” of Heat Transport Pressure Control. In the “solid mode” feed and bleed flows are regulated by the heat transport reactor outlet header pressure controller, and all inventory changes are via the D2O Storage Tank.
- (4) Note that the same equipment i.e. feed and bleed circuit is used for inventory control in either mode, but in “normal mode” the setpoint is pressurizer level as indicated by arrow (a), and in “solid mode” the setpoint is heat transport “solid mode” pressure, shown by arrow (b). It is also very important to remember that in “normal mode” pressurizer level setpoint is a function of reactor power.

9. INVENTORY CONTROL

- ▶ (1) Inventory control for the heat transport system is achieved by feed and bleed, and is designed to compensate for volume changes as a function of coolant temperature. Inventory and Pressure Control are closely linked, since changing the one will alter the other. There are significant differences in handling inventory between “normal” and “solid” modes of pressure control.
- ▶ (2) In “normal mode” the pressurizer controls main circuit pressure, while inventory and therefore feed and bleed flows are regulated by the pressurizer level controller. Short term inventory changes will be reflected by Pressurizer level changes, and the feed and bleed system will eliminate pressurizer level error by supplying heavy water from or storing it in the D2O Storage tank.
- ▶ (3) When the Pressurizer is isolated from the main circuit, typically under warm-up and cool-down conditions, both heat transport pressure and inventory control are performed by the feed and bleed circuit. This condition is referred to as the “solid mode”. In the “solid mode” feed and bleed flows are regulated by the heat transport reactor outlet header pressure controller, and all inventory changes are via the D2O Storage Tank.
- ▶ (4) Note that the same equipment i.e. feed and bleed circuit is used for inventory control in either mode, but in “normal mode” the setpoint is pressurizer level, and in “solid mode” the setpoint is heat transport “solid mode” pressure.

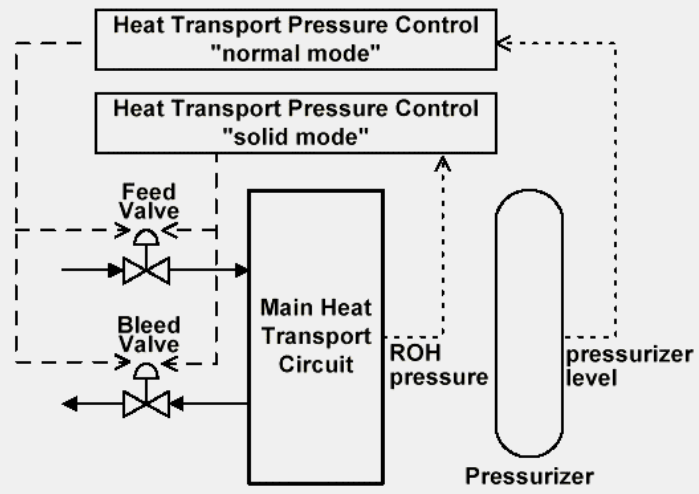

10. STORAGE AND CHEMICAL CONTROL

In the previous sections I made passing references to the D2O Storage Tank and to the Heat Transport Purification System. In this section we take a closer look at the functions and equipment associated with D2O Storage and Chemical Control.

- (1) The D2O Storage Tank is used to hold the excess inventory of heavy water in the Heat Transport system. Units that use a Pressurizer for main circuit pressure and inventory control need the Storage Tank for inventory changes during system warm-up and cooldown, and in case of certain abnormal operations. For a “feed-and-bleed” type Heat Transport pressure control system the Storage Tank is the only source and sink for the volume of coolant added to or removed from the main circuit.
- (2) The temperature and pressure of the bleed flow from the heat transport system must be reduced to around 60°C in order to avoid damage to the ion exchange resin in the purification system, to ensure feed pump net positive suction head, and before transfer to the Storage Tank.
- (3) The required temperature reduction is achieved by the Bleed Cooler identified at arrow (a), in which the outflow from the Bleed Condenser is cooled using recirculated service water. The flow of cooling water is regulated by the Bleed Cooler Temperature Control valves, at arrow (b). In case the temperature of the heavy water is too high and presents a risk of damage to the ion exchange columns, the Bleed Condenser level control valves, at arrow (c) close automatically. This action, however, reduces and in some cases prevents any further outflow from the Bleed Condenser. If the temperature and/or pressure at the outlet of the Bleed Condenser are too high, the motorized valves in the inlet and outlet lines of the Purification System close and the by-pass valve opens.

10. STORAGE AND CHEMICAL CONTROL

- (1) The D₂O Storage Tank is used to hold the excess inventory of heavy water in the Heat Transport system. Units that use a Pressurizer for main circuit pressure and inventory control need the Storage Tank for inventory changes during system warm-up and cooldown, and in case of certain abnormal operations. For a “feed-and-bleed” type Heat Transport pressure control system the Storage Tank is the only source and sink for the volume of coolant added to or removed from the main circuit.
- (2) The temperature and pressure of the bleed flow from the heat transport system must be reduced to about 50°C to avoid damage to the ion exchange resin in the purification system, to ensure feedpump net positive suction head, and before transfer to the Storage Tank.
- (3) The required temperature reduction is achieved by the Bleed Cooler, in which the outflow from the Bleed Condenser is cooled using recirculated service water. In case the temperature of the heavy water is too high and presents a risk of damage to the ion exchange columns, the Bleed Condenser level control valves close automatically. This action, however, reduces and in some cases prevents any further outflow from the Bleed Condenser.

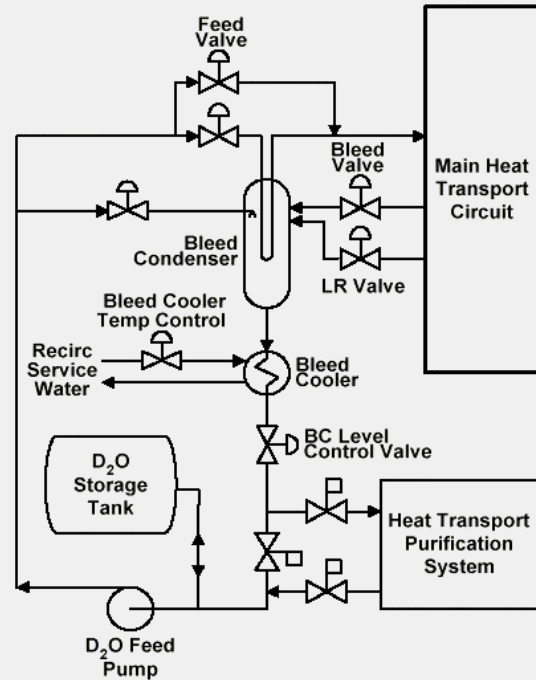

11. HEAT TRANSPORT OVER-PRESSURE PROTECTION

All vessels under pressure must have some form of over-pressure protection. Since the Heat Transport System operates at pressures in the order of 10 Mega Pascals, the main system as well as key pieces of equipment are each provided with their own means of over-pressure protection. Because of the high cost of heavy water and the potential for the coolant to be radioactive, special measures have been devised to contain the outflow of heavy water from a circuit component where over-pressure protection is applied. Either pneumatic control valves or fast acting relief valves are used for over-pressure protection in the Heat Transport System.

- (1) The Liquid Relief valves are designed to prevent main heat transport high pressure transients exceeding system limits. Opening the Liquid Relief (LR) valves to the bleed condenser will usually avoid a reactor trip on high Heat Transport pressure.
- (2) The Pressurizer Over-pressure Relief Valve provides pressure relief for the pressurizer in the event of equipment failure, such as one or more heaters remaining ON when no longer required, or some types of control system failures that result in a high pressure transient. This protection is provided by the pressurizer over-pressure (O/P) steam relief valves to the bleed condenser.
- (3) In cases when one of the valves connecting bleed or relief flow to the Bleed Condenser fails in the open position, the bleed condenser will fill up and reach the pressure of the main circuit. This condition is sometimes referred to as the Bleed Condenser “going solid” as it becomes part of the heat transport system boundary. As such, the Bleed Condenser itself must have protection to prevent its own pressure and that of the rest of the heat transport system from exceeding the prescribed limits. This protection is provided by the bleed condenser relief valves to the reactor building sumps.
- (4) I had mentioned the need to protect the Purification System from excessively high temperatures. Similarly, the ion exchange columns have to be protected against excessive pressures. The purification circuit is protected by closing the motorized valve in the inlet line (a), the one in the outlet line (b), and opening the by-pass valve (c), if the inlet pressure to the Purification System exceeds the specified limit.
- (5) To prevent over pressure damage to the reflux feed line, the Relief Valve will open and by-pass some of the flow to the storage tank tie line.

11. HEAT TRANSPORT OVER-PRESSURE PROTECTION

- ▶ (1) Prevent main heat transport high pressure transients exceeding system limits. Opening the Liquid Relief (LR) valves to the bleed condenser will usually avoid a reactor trip on high HT pressure.
- ▶ (2) Provide pressure relief for the pressurizer in the event of equipment failure (i.e. heaters remaining On) or control system failure that results in a high pressure transient. This protection is provided by the pressurizer over-pressure (O/P) relief valves to the bleed condenser.
- ▶ (3) Provide pressure relief valve (RV) for the bleed condenser; for example if it goes "solid" and becomes the heat transport system boundary, it must prevent the heat transport system pressure exceeding system limits. This protection is provided by the bleed condenser relief valves to the reactor building sumps.
- ▶ (4) Prevent over pressure damage to the purification circuit by by-passing purification flow if the inlet pressure to the Purification System exceeds the specified limit.
- ▶ (5) Prevent over pressure damage to the reflux feed line by the Relief Valve opening and by-passing some of the flow to the storage tank tie line.

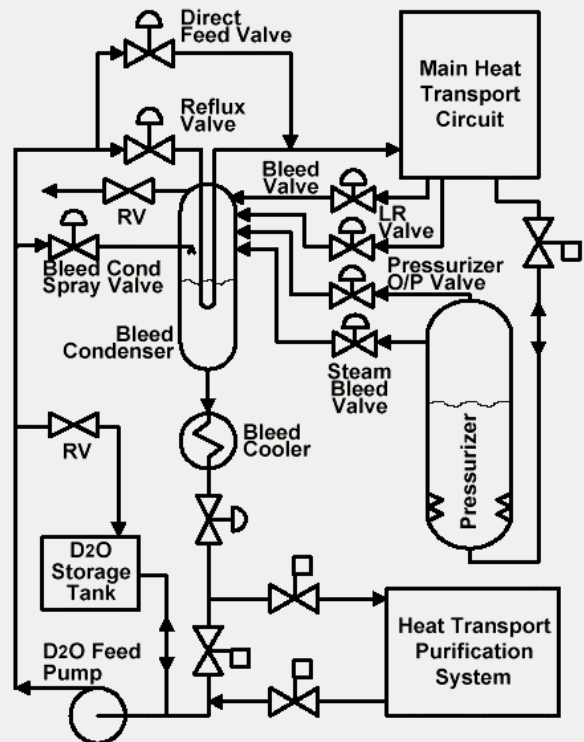

12. CANDU 9 PRESSURE AND INVENTORY CONTROL SYSTEM

The diagram shows the main equipment of the CANDU 9 pressure and inventory control system. In this Session we have covered all the main pieces of equipment in this system, and you should be able to recognize and recall the main design and operating parameters and functions of the equipment and how they perform to meet the system's operating requirements.

You will need to enlarge the diagram on your screen and/or use the printed version in your notes to see the details more clearly. You will also need to make sure that you can correlate the equipment as described in this Session and as implemented on the simulator. You will do this to some extent in Problem 4.1.

Please select each action arrow and make sure that you can recall the purpose of each piece of equipment and how it interacts with the rest of the Pressure and Inventory Control System.

- (1) Pressurizer and associated valves
- (2) Bleed Condenser and associated valves
- (3) Feed and Bleed valves, Feed pumps
- (4) Bleed Cooler
- (5) Over-pressure Protection
- (6) D₂O Storage and Purification

SESSION 4: STEAM, TURBINE AND FEEDWATER SYSTEMS

MODULE CONTENTS

1.	INTRODUCTION	page 2
2.	STEAM GENERATOR	page 3
3.	MAIN STEAM SYSTEM	page 4
4.	STEAM UTILIZATION IN THE TURBINE	page 5
5.	TURBINE BYPASS	page 6
6.	EXTRACTION STEAM	page 6
7.	TYPICAL CANDU MAIN STEAM SYSTEM	page 7
8.	FEEDWATER SYSTEM	page 8
9.	LOW PRESSURE FEEDHEAT SYSTEM	page 8
10.	DEAERATOR AND STORAGE TANK	page 9
11.	HP FEEDHEATING SYSTEM	page 9
12.	STEAM GENERATOR FEED PUMPS AND LEVEL CONTROL VALVES	page 10
13.	STEAM GENERATOR LEVEL CONTROL REQUIREMENTS	page 11
14.	STEAM GENERATOR LEVEL - ONE ELEMENT CONTROL	page 12
15.	STEAM GENERATOR LEVEL - THREE ELEMENT CONTROL	page 13

1. INTRODUCTION

This Session describes the functions and characteristics of the Steam, Turbine, Generator and Feedwater systems. The Steam and Feedwater systems form the normal heat sink for the energy produced by the Reactor and transferred to the Steam Generators by the Heat Transport system. As such, the operation of the Steam and Feedwater systems is important from the reactor safety point of view, and since the steam normally drives the turbine-generator, also for the economic operation of the unit.

The diagram shows the systems described in this Session, namely:

- (1) The Steam Generator, where the heat from the Heat Transport System heavy water is transferred to the secondary side's light water. The feedwater that enters the steam generators leaves as dry steam. Because the basic process that takes place in the steam generators is the boiling of water, the steam generators are often referred to as "boilers".
- (2) The Main Steam System collects the steam from the four steam generators and distributes it to the various steam loads. During normal operations, most of the steam flows to the turbine. If the turbine is not available, the steam can flow directly to the condenser or be released to the atmosphere.
- (3) The Turbine converts the latent heat energy of the steam to rotational energy. The Turbine in a CANDU generating unit consists of one high pressure stage followed by three parallel low pressure stages.
- (4) The Generator is connected to the same shaft as the Turbine and it converts the rotational energy of the Turbine to produce electricity. In this course we will not go into any details regarding the Generator and the electrical system.
- (5) The steam that has passed through the low pressure turbine is cooled and converted back to water in the Condenser. Cooling of the Condenser involves the rejection of approximately 65% of the energy produced by the reactor, requiring a large amount of water and a large heat sink, such as the sea, river or lake.
- (6) The Feedwater and Feedheating system pumps and heats the condensate and returns it to the steam generators.

In this Session I summarize the main processes that take place in the above systems, and also describe the key features of the steam generator level control system.



1. INTRODUCTION

This Session describes the functions and characteristics of the Steam, Turbine, Generator and Feedwater systems. The Steam and Feedwater systems form the normal heat sink for the energy produced by the Reactor and transferred to the Steam Generators by the Heat Transport system. As such, the operation of the Steam and Feedwater systems is important from the reactor safety point of view, and since the steam normally drives the turbine-generator, also for the economic operation of the unit.

The diagram shows the systems described in this module, namely:

- (1) Steam Generator
- (2) Main Steam
- (3) Turbine
- (4) Generator
- (5) Condenser
- (6) Feedwater

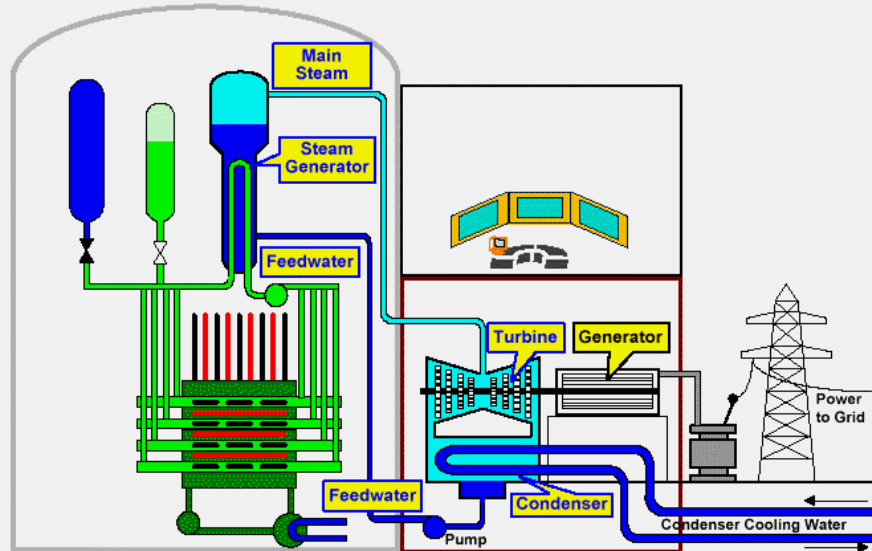

2. STEAM GENERATOR

There are four identical steam generators in a CANDU unit. A typical steam generator is shown on the diagram. The tube bundle, in the shape of an inverted U, carries the heat transport heavy water, called the primary side, from which the heat is transferred to the light water on the secondary side. The tube sheet supports the thousands of tubes that make up the tube bundle. The temperature of the incoming feedwater is raised to the saturation point in the integral Preheater. Boiling takes place throughout the rest of the steam generator, and the dry steam leaves at the top of the steam generator.

- (1) The hot pressurized heat transport heavy water enters the boiler and passes up through what is referred to as the “hot leg” of the tube bundle. Past the U-bend the heavy water has given up some of its heat, so the down side is called the “cold leg”. Throughout the length of the tube bundle the heat that is transferred from the heavy water to the light water causes the latter to boil. The final stage of heat transfer before the heavy water leaves the steam generator takes place in the Preheater, where the feedwater is brought to the saturation temperature. Once past the Preheater, the Feedwater is at saturation conditions, and the additional heat that it receives causes further boiling, that is increasing the steam content and reducing the water content of the steam-water mixture. Since the mixture is at saturation, it has the same temperature and pressure throughout the boiling section of the steam generator.
- (2) As the feedwater turns into a steam-water mixture it becomes lighter and will rise in the steam generator. The section along the tube bundle is also called the “riser” for this reason. The steam-water mixture at the top of the tube bundle does not contain a lot of steam, it is about 90% water. It is essential that as much as possible of the water be removed from the mixture before the steam leaves the steam generator. High moisture content would damage the piping and valves in the steam lines, and most importantly could do severe damage to the turbine. It is therefore essential that only dry steam leaves the boiler.
- (3) As the steam-water mixture rises above the tube bundle it enters the Steam Drum. An arrangement of steel plates, called “Cyclone Separators” force the steam-water mixture into a swirling centrifugal motion, which results in the water droplets moving to the outside area of the separator where they are drained off. The steam flows upwards as it becomes lighter with the removal of the moisture content. The final stage of drying the steam takes place in a second stage of water removal called “scrubbers”, which are located above the cyclone separators. The steam that leaves the steam drum had its moisture content reduced to about 0.1% from the 90% that entered the steam drum.
- (4) The water that is separated from the steam in the cyclone separator and steam scrubber drains to the outside of the steam generator's Tube Shroud and flows down in the Downcomer annulus that is formed between the Tube Shroud and the Shell. The water falls to the bottom of the steam generator where it re-enters the tube bundle area to be heated once again. The amount of water cycling through the tube bundle and the Downcomer, is typically ten times as much as feedwater entering the boiler.
- (5) The feedwater flow in the steam generator starts at the Preheater. Using the heat that remains in the heavy water after much of it has been used to boil the light water, the Preheater heats the feedwater to near saturation temperature. Inside the steam generator the feedwater circulates up around the tube bundle and down the downcomer many times while acquiring the latent heat of vaporization, and eventually leaving the steam generator as saturated steam.

▶▶ 2. STEAM GENERATOR

- ▶▶ (1) Hot pressurized heat transport heavy water enters the boiler and passes through the tube bundle. Heat transfers from the heavy water to the feedwater, causing the feedwater to boil.
- ▶▶ (2) The steam leaving the top of the tube bundle is about 90% water. To prevent damage to the turbine, only dry steam must leave the boiler.
- ▶▶ (3) Cyclone separators, located above the tube bundle, dry the steam by giving the steam/water mixture a swirling centrifugal motion. The steam scrubbers, located above the cyclone separators, remove the last traces of moisture. The water, being denser than steam, moves to the outside area of the separator and is drained off.
- ▶▶ (4) Water separated from the steam in the cyclone separator and steam scrubber drains to the outside of the boiler's tube shroud and flows down in the downcomer to the bottom of the boiler. The amount of water cycling through the tube bundle and the downcomer, is typically ten times as much as feedwater entering the boiler.
- ▶▶ (5) The feedwater flow in the boiler starts from the preheater. The preheater heats the feedwater to near saturation temperature. Inside the boiler the feedwater circulates up around the tube bundle and down the downcomer many times while acquiring the latent heat of vaporization, and leaves the boiler as saturated steam.

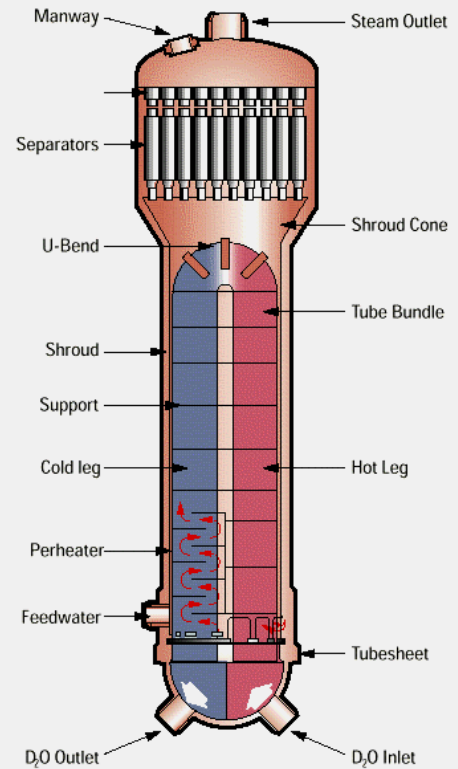

3. MAIN STEAM SYSTEM

The diagram shows a simplified diagram of the Steam System for a typical CANDU unit. Starting from the Boilers, under normal operating conditions the steam flows to the High Pressure Turbine as indicated by arrow (a), then through the Moisture Separator to the Reheater, indicated at arrow (b), from there to the Low Pressure Turbine, and finally at arrow (c) the steam is exhausted to the Condenser, where it is returned to the liquid phase. This section deals with the steam flow through the Main Steam System to the High Pressure Turbine.

- (1) As we have seen before, the steam generators, being pressure vessels, must have protection against over-pressure. Steam pressure is normally controlled by varying the steam flow through the Governor Valves, but if steam pressure rises above predetermined limits, the Atmospheric and Condenser Steam Discharge Valves can be opened by the Steam Generator Pressure Control System. If the pressure continues to increase, then the Safety Valves installed on top of the boiler will open to protect the steam system from over pressure.
- (2) The pressure from the boilers drives the steam to the high pressure (HP) turbine through the Emergency Stop Valves (ESV) and the Governor Valves (GV). Under normal operating conditions the Emergency Stop Valves are fully open and the Governor Valves are adjusted to control steam flow into the turbine. The steam safety and discharge valves are normally closed.
- (3) The purpose of the Emergency Stop Valves is to quickly stop the steam flow to the turbine to prevent it from over-speeding and getting damaged when the load on the generator is suddenly removed. Following a turbine trip, when the turbine is to be restarted, the ESVs are first opened with the Governor valves closed, so that the ESVs are available to perform their protective function once steam is again admitted to the turbine.
- (4) The Governor Valves control the quantity of steam flowing to the turbine. As we have seen in Session 1, in "Normal Mode" the governor valves are adjusted to control the electrical output of the unit. In "Alternate Mode" with the generator synchronized to the grid, the Governor valves are adjusted to maintain steam pressure constant, and in the process also alter generator output. When the generator is not connected to the grid, the governor valves are used to control the speed of the turbine. In cases when the generating unit is the only or main supplier of electricity to the system, the governor valves also control the frequency of the "load island".

4. STEAM UTILIZATION IN THE TURBINE

As indicated on the diagram, the steam comes into the High Pressure Turbine from the steam generators at arrow (a). After the High Pressure Turbine the steam passes through the moisture separator and reheater which are not shown on this particular diagram, and then is distributed at arrow (b) to the three parallel connected Low Pressure Turbines. Each of the three LP Turbines exhausts the steam flow to its own Condenser, as indicated by arrow (c).

- (1) From the governor valve the steam passes through the HP turbine. Some of the latent heat of the steam is converted to rotational energy, and in this process the moisture content of the steam increases to about 10% when it leaves the HP Turbine. The pressure and temperature of the steam as it leaves the High Pressure Turbine have been reduced to approximately 900 kPa and 170°C. The moisture will need to be removed and the pressure and temperature raised before the steam enters the low pressure turbines.
- (2) The steam outlet from the HP Turbine stage passes to the moisture separator which removes the moisture in the steam without changing its temperature and pressure. The water is collected in the Separator Drains Tank and is pumped to the Deaerator.
- (3) The Reheater is used to raise the temperature and pressure of the steam that flows from the Separator to the Reheater, at arrow (a). As shown on the diagram at arrow (b), a flow of steam is taken directly from the boiler to the Reheater, and its heat is used to raise the pressure and temperature of the steam from the moisture separator to 230°C and 900 kPa, which correspond to superheated conditions. Since the Reheater drains are at saturation temperature, they can be returned directly to the steam generators, as shown by the red line. In some station designs the Reheater Drains are connected to the High Pressure Heaters.
- (4) Before entering the LP turbine, the steam passes through intercept valves. In a fashion similar to the emergency stop valves, these valves shut off the flow of steam to the LP Turbine in case the load to the generator is disconnected. The amount of energy in the volume of steam in the HP Turbine, Moisture Separator, Reheater and the interconnecting pipes is such that it could result in over-speeding the turbine and damaging it.
- (5) The steam finally passes through the Low Pressure Turbine and is then exhausted to the Condenser at approximately 5 kPa(a), 35°C and 10% moisture content. The diagram shows a typical Low Pressure Turbine stage. The steam enters near the center of the turbine, flows through the turbine blades in both directions, and is then exhausted to the Condenser at the two ends of the Turbine.

▶ 4. STEAM UTILIZATION IN THE TURBINE

- ▶ (1) From the governor valve the steam passes through the HP turbine, where its pressure and temperature are reduced to approximately 900 kPa and 170°C, while the moisture content increases to about 10%.
- ▶ (2) After the HP Turbine the steam passes to the moisture separator which removes the moisture. The steam leaving the moisture separator has the same temperature and pressure as that at the turbine outlet but without moisture.
- ▶ (3) The steam next passes through a Reheater, which uses steam directly from the boiler to heat the steam from the moisture separator to a superheated condition at about 230°C and 900 kPa. Since the Reheater drains are at saturation temperature, they are returned directly to the boilers.
- ▶ (4) Before entering the LP turbine, the steam passes through intercept valves. In a fashion similar to the emergency stop valves, these valves shut off steam to the LP turbine to prevent over-speed conditions.
- ▶ (5) The steam finally passes through the low pressure turbine and is then exhausted to the condenser at approximately 5 kPa(a), 35°C and 10% moisture content.

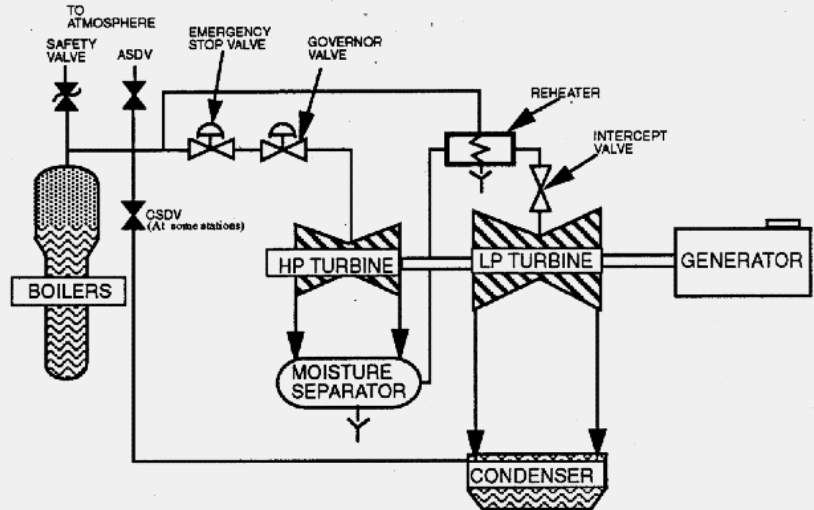

5. TURBINE BYPASS

When the turbine is unable to accept the steam flow, typically following a turbine trip, during turbine shutdown or a rapid reduction in generator output, the steam flow can bypass the turbine and flow directly to the condenser. The diagram illustrates the flow of steam when the ESVs and GVs are closed, and the CSDVs are open, with the red arrows showing the flow of steam to the Condenser.

- (1) Condenser Steam Discharge Valves (CSDVs) are installed to allow the steam to bypass the turbine and flow directly to the condenser on loss of turbine so that the reactor can continue to operate at the power required to prevent a 'poison-out'. They are also used to discharge steam on a loss of line, or on a turbine trip, so that the main steam safety valves do not lift. There are 12 CSDVs, connected in such a way that each valve discharges steam to one half of one condenser shell. The total capacity of the CSDVs is 100%FP flow rate. This capacity is usually needed for about one minute, while the reactor power is runback to 60%FP. Under normal operating conditions the steam generator pressure will need to rise 100kPa above its setpoint for the CSDVs to begin to open.
- (2) Atmospheric Steam Discharge Valves (ASDV) are low capacity valves used to control steam generator pressure via the steam pressure control program. They are opened in proportion to the pressure error, normally with an offset of 70 kPa in the steam pressure setpoint. These valves may also be used to provide a heat sink during shutdown for decay heat removal when the main condenser is unavailable.

6. EXTRACTION STEAM

The efficiency of the thermo-dynamics of the steam and feedwater cycle can be optimized by taking some of the energy of the steam at various points between the main steam header and the low pressure turbine and using it to heat the feedwater.

Extraction Steam is supplied to the following heat exchangers:

- (a) three stages of low pressure heaters;
- (b) the deaerator that forms the fourth stage of feedwater heating;
- (c) the fifth stage consists of two high pressure heaters connected in parallel.

▶ 5. TURBINE BYPASS

- ▶ (1) Condenser Steam Discharge Valves (CSDV) are installed to allow the steam to bypass the turbine and flow directly to the condenser on loss of turbine so that the reactor can continue to operate at the power required to prevent a 'poison-out'. They are also used to discharge steam on a loss of line, or on a turbine trip, so that the main steam safety valves do not lift.
- ▶ (2) Atmospheric Steam Discharge Valves (ASDV) are low capacity valves used to control steam generator pressure via the steam pressure control program. They are opened in proportion to the pressure error, normally with an offset in the steam pressure setpoint. These valves may also be used to provide a heat sink during shutdown for decay heat removal when the main condenser is unavailable.

▶ 6. EXTRACTION STEAM

The efficiency of the thermodynamics of the steam and feedwater cycle can be optimized by taking some of the energy of the steam at various points between the main steam header and the low pressure turbine and using it to heat the feedwater. Extraction Steam is supplied to the following:

- (a) low pressure heaters
- (b) deaerator
- (c) high pressure heaters

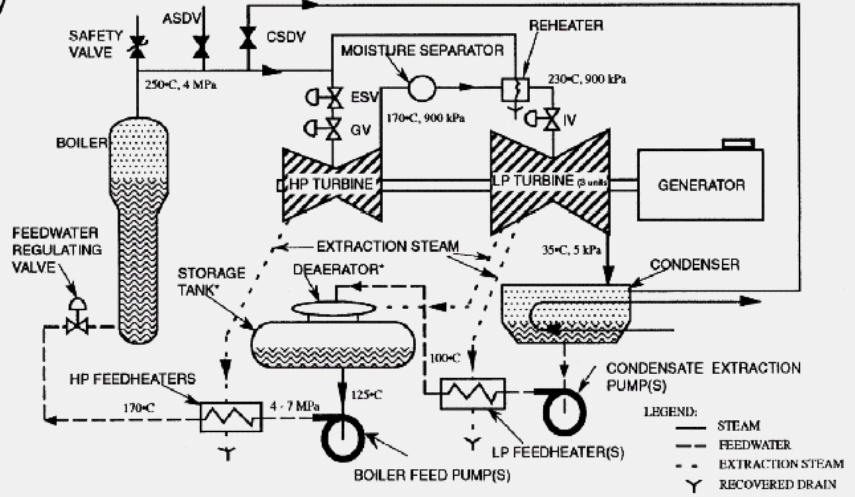

* Physically the highest vessel in the system

7. TYPICAL CANDU MAIN STEAM SYSTEM

A typical CANDU Main Steam System contains a large number of valves for control and safety purposes.

- (1) Turbine Stop Valves
- (2) Condenser Steam Discharge Valves
- (3) Atmospheric Steam Discharge Valves
- (4) Main Steam Safety Valves
- (5) The Feedwater Flow is controlled by a set of valves which are described in Sections 12 and 13 of this Session.
- (6) The Main Steam Flow Measurements are used as part of the Steam Generator Level Control system, as described in Sections 14 and 15 of this Session.

7. TYPICAL CANDU MAIN STEAM SYSTEM

A typical CANDU Main Steam System contains a large number of valves for control and safety purposes.

- ➡ (1) Turbine Stop Valves
- ➡ (2) Condenser Steam Discharge Valves
- ➡ (3) Atmospheric Steam Discharge Valves
- ➡ (4) Main Steam Safety Valves
- ➡ (5) Feedwater Flow
- ➡ (6) Main Steam Flow Measurements

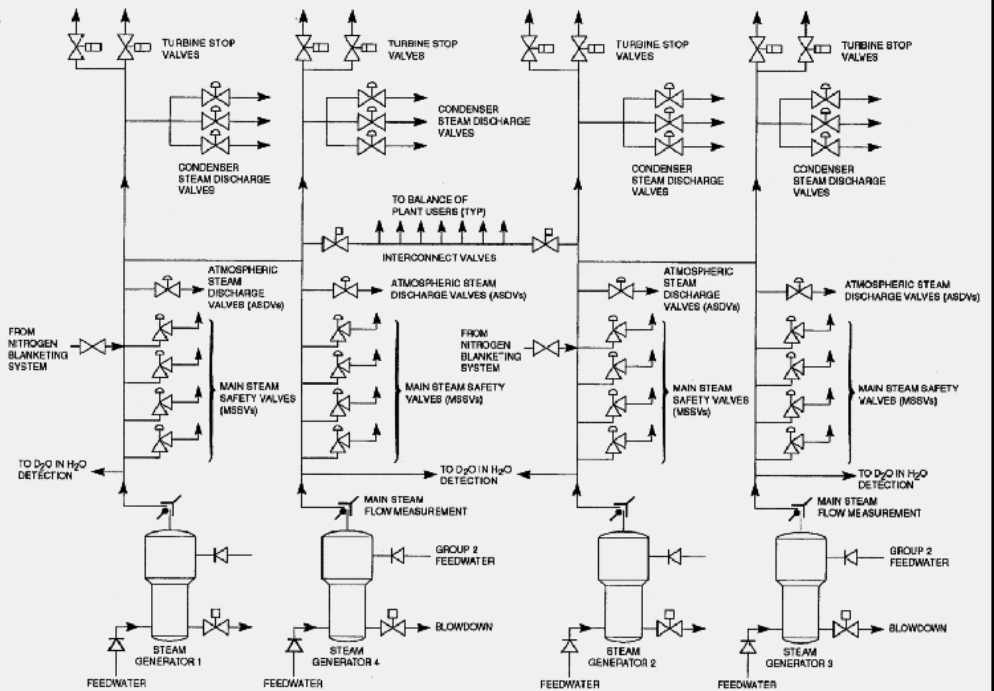

8. FEEDWATER SYSTEM

The feedwater system encompasses the flow of water from the condenser to the steam generators, and its heating through the Low Pressure Heaters, Deaerator and High Pressure Heaters. Starting at arrow

- (a) The water leaving the condenser is at relatively low temperature and pressure. The Condensate Extraction Pump (CEP) pumps the water from the Condenser Hotwell through the Low Pressure Heaters into the Deaerator. As shown by arrows
- (b) a series of heat exchangers raises the Condensate temperature to about 170°C. The heating stages include the Low Pressure Heaters, the Deaerator and the High Pressure Heaters. The final stage of feedheating takes place in the Preheater, which as I describe in Section 2 of this Session is integral to the steam generator, as indicated by arrow
- (c) The Preheater increases the temperature of the feedwater to almost saturation conditions. Since the steam generator is normally operated above 4 MPa, high pressure and high capacity pumps are needed to force the feedwater into the steam generators. As indicated by arrow
- (d) the boiler (or steam generator) feed pumps (BFP) take their suction from a line coming from the Deaerator and pump the feedwater through the High Pressure Feedheaters and the Feedwater Regulating Valves into the steam generator.

9. LOW PRESSURE FEEDHEAT SYSTEM

The flow of feedwater begins at the Condenser Hotwell. As shown on the diagram, the steam from the Low Pressure Turbine enters the Condenser at the top. The steam is cooled and condensed by the cooling water flowing through the horizontal condenser tubes and collects in the Hotwell at the bottom of the Condenser. The Condenser Cooling Water enters at the Inlet Box and leaves the Condenser through the Outlet box, as indicated by blue arrows.

- (1) The Condensate Extraction Pump (CEP) delivers the condensate from the Condenser Hotwell to the Low Pressure heaters.
- (2) The LP feedheaters use extraction steam from the LP turbines as their heating medium. The extraction steam condenses in the shell of the heater. A separate pump recovers this condensate by pumping it to the condenser hotwell. The feedwater leaves the last LP feedheater at approximately 100°C.

10. DEAERATOR AND STORAGE TANK

- (1) The Deaerator is the next stage in the feedwater heating process. This is the highest vessel in the feedheating system, in order to ensure that a net positive suction head is provided for the steam generator feed pumps. The Deaerator adds heat to and removes non-condensable gases from the feedwater.
- (2) The diagram illustrates the main parts and fluid flows in the Deaerator, the top part, and the associated Storage Tank, the bottom part. The incoming feedwater enters the Deaerator near the top at arrow (a) and sprays downward over cascade trays, referenced by arrow (b). Extraction steam indicated by arrow (c) from the LP turbine enters the Deaerator near the bottom and passes upward. As a result the feedwater heats up to about 125°C. The deaerated feedwater and condensed steam drain from the Deaerator into the Storage Tank.

11. HP FEEDHEATING SYSTEM

The High Pressure Feedheating System includes the steam generator feed pumps and the High Pressure Heaters.

- (1) The boiler feed pumps (BFP) take suction from the Deaerator Storage Tank and raise the feedwater pressure to between 4 and 7 MPa. The pumps discharge the high pressure feedwater to the high pressure (HP) feedheaters.
- (2) The HP feedheaters heat the feedwater to about 170°C. HP feedheater operation and construction are similar to that of the LP feedheaters. Extraction steam from the HP turbine normally supplies the heat, as shown by arrow (a). The condensed steam, at arrow (b) is directed to the Deaerator Storage Tank.

10. DEAERATOR AND STORAGE TANK

- ▶ (1) The deaerator is the next stage in the feedwater heating process. This is the highest vessel in the feedheating system. The deaerator adds heat to and removes non-condensable gases from the feedwater.
- ▶ (2) The incoming feedwater enters the deaerator near the top and sprays downward over cascade trays. Extraction steam from the LP turbine enters the deaerator near the bottom and passes upward. As a result the feedwater heats up to about 125°C. The deaerated feedwater and condensed steam drain from the deaerator into a storage tank. The storage tank supplies water for boiler operation.

▶ 11. HP FEEDHEATING SYSTEM

- ▶ (1) The boiler feed pumps (BFP) take suction from the deaerator storage tank and raise the feedwater pressure to between 4 and 7 MPa. The pump discharges the high pressure feedwater to the high pressure (HP) feedheaters.
- ▶ (2) The HP feedheaters heat the feedwater to about 170°C. HP feedheater operation and construction are similar to that of the LP feedheaters. Extraction steam from the HP turbine normally supplies the heat.

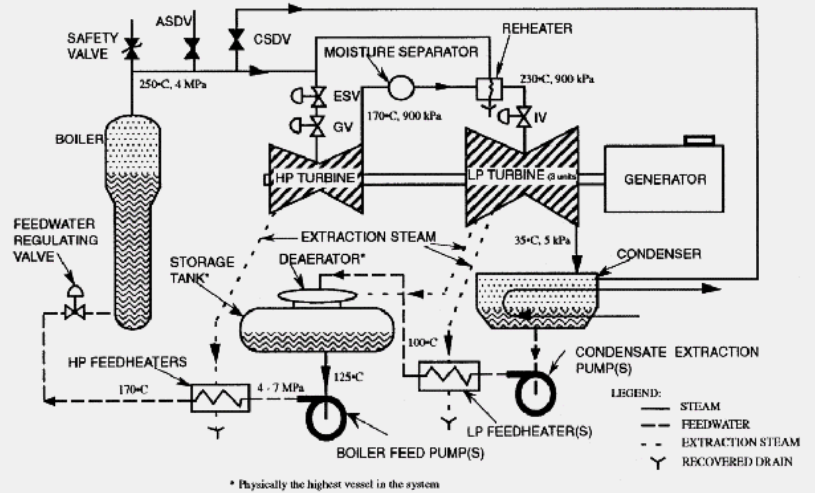

12. STEAM GENERATOR FEED PUMPS AND LEVEL CONTROL VALVES

The diagram shows the main pieces of equipment typical for a CANDU High Pressure Feedwater system. Starting with the Deaerator, highlighted in a blue frame, the flow of feedwater is to the suction of the steam generator feedpumps, shown inside a purple frame. The two parallel high pressure heaters are indicated by a green frame, and the four sets of feedwater flow control valves, which are controlled by the steam generator level controller, are highlighted by the red frames.

- (1) Two 50% capacity main steam generator feed pumps are required to supply the necessary flow to the steam generators above 25% full power, and one additional pump is on standby. At some stations three 33% pumps are used, for example the system modelled on the Simulator.
- (2) One auxiliary pump is also provided, it is sized so that it can supply the flow to remove decay heat in case of a loss of Class IV supply to the main pumps. You will find two such pumps on the Simulator. The choice depends on the reliability of the pump used.
- (3) Connections to the Condensate system allow for recirculating flow when the pumps are operating but the level control valves are closed. These lines are shown in red on the diagram. Additional details are available on the Simulator.
- (4) The level in each steam generator is controlled individually. Because of safety, range of control and maintenance considerations, each steam generator has a set of three control valves for feedwater control connected in parallel: one small valve to control feedwater during shutdown, startup, and low power operation, and two larger valves to control feedwater for on-power conditions. Each of the two large valves can handle the full power flow requirements. Isolating valves are provided for each control valve.

The highlighted portion shows one typical set of valves for one steam generator. Flow to the valves is indicated by the vertical arrow, flow from the valves towards the steam generators by the horizontal arrow. Note that the large control valves Fail Closed (FC) on a loss of air pressure, while the auxiliary valve Fails Open (FO). Either of a pair of large control valves can supply 100% flow to its steam generator. Each control valve has a motorized isolating valve (shown with the square flag) in series with it.

12. STEAM GENERATOR FEED PUMPS AND LEVEL CONTROL VALVES

- ▶ (1) Two 50% capacity main steam generator feed pumps are required to supply the necessary flow, and one additional pump is on standby.
- ▶ (2) One auxiliary pumps is also provided, it is sized so that it can supply the flow to remove decay heat in case of a loss of Class IV supply to the main pumps.
- ▶ (3) Connections to the Condensate system allow for recirculating flow when the pumps are operating but the level control valves are closed.
- ▶ (4) The level in each steam generator is controlled individually. Because of safety, range of control and maintenance considerations, each steam generator has a set of three control valves for feedwater control connected in parallel: one small valve to control feedwater during shutdown, startup, and low power operation, and two larger valves to control feedwater for on-power conditions. Each of the two large valves can handle the full power flow requirements. Isolating valves are provided for each control valve.

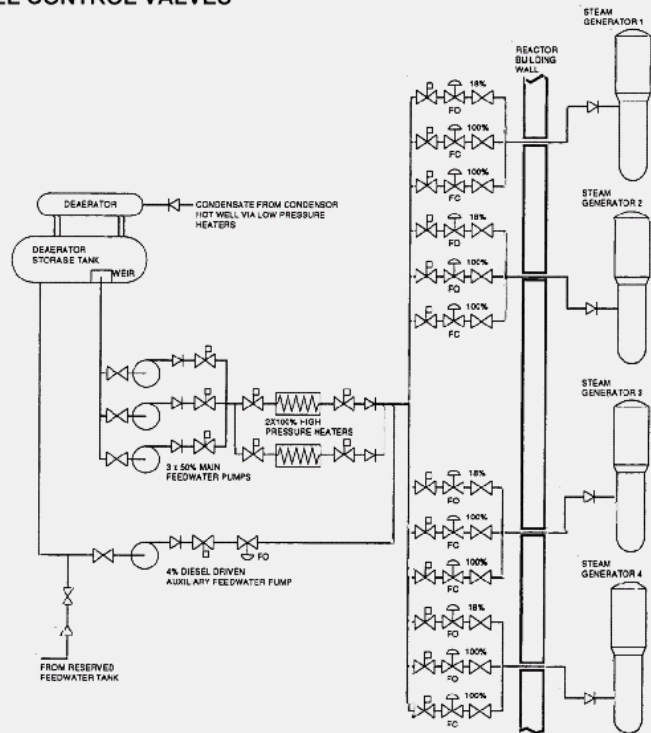

13. STEAM GENERATOR LEVEL CONTROL REQUIREMENTS

- (1) The steam generators are the normal heat sinks for the reactor, so in order to ensure cooling of the fuel, it is very important to maintain the ability of the steam generators to remove the heat from the heat transport system. Heat removal ability requires that there be an adequate volume of water in the steam generators to be converted to steam, and the means to remove the steam. As I note in Section 3 of this Session, normal steam flow is to the Turbine. However if the turbine is not available, the atmospheric and condenser discharge valves are able to control the flow of steam while maintaining the steam pressure at the set-point.
- (2) If steam generator level goes too high, there is a potential of water droplet carry-over to the high pressure turbine, which could damage the turbine blades. The level control system needs to ensure that steam generator level is maintained between the required limits. This is not a simple task, because of the level of water under boiling conditions can vary by significant amounts under a variety of system upset conditions, depending on how much steam is contained in the form of bubbles in the water. In order to ensure that the turbine is protected from water carry-over, the turbine will be automatically tripped if the level in the steam generator goes too high.
- (3) The volume of water at a constant steam generator level will decrease as reactor power is increased because of bubble formation. To keep the volume of water constant at all power levels, steam generator level set-point varies as a function of reactor power.
 - (a) Sudden changes in steam generator pressure will also impact on steam generator level: an increase in pressure will collapse the bubbles, dropping level, while a sudden decrease in pressure will result in more bubbles and will raise the level.
 - (b) Sudden changes in steam flow will result in sudden pressure changes and hence steam generator level changes.
 - (c) Sudden changes in feedwater flow will also impact on bubble formation and will therefore cause level changes (in addition to the change resulting from the water volume change itself).
- (4) In order to control steam generator level close to its set-point, the control algorithm includes steam flow and feedwater flow, in addition to steam generator level measurements. This is called "three element" control, because three different signals are used to determine the controller action. The controller acts on the feedwater control valves to regulate the flow of feedwater into the steam generator. Because of the interrelations between level measurement, volume of water in the steam generator, the flow of water into the steam generator, changes in steam flow and pressure, the level controller algorithm is quite complex.

14. STEAM GENERATOR LEVEL - ONE ELEMENT CONTROL

Under low power conditions or if the flow measurements are not available, the steam generator level controller can be operated as a single element controller. The setpoint and hence the single element may be either level or feedwater flow, if an accurate flow measurement is available.

- (1) In the case of One Element Level Control, the setpoint is the desired steam generator level, which is compared with the measured level.

As shown by arrow (a), the level error is computed as the difference between the level set-point and the actual (that is measured) level. The resultant controller signal is fed to the feedwater control valve's actuator at arrow (b), which will alter the valve opening and hence the flow of feedwater to the steam generator.

For example an actual level below the set-point results in a positive error, which will increase the valve opening and hence allow more feedwater to flow into the steam generator.

- (2) In the case of One Element Flow Control, the setpoint is the desired feedwater flow, which is compared with the measured flow.

As shown by arrow (a), the flow error is the difference between the flow set-point and the actual (that is measured) flow. The resultant controller signal is fed to the feedwater control valve's actuator at arrow (b), which will alter the valve opening and hence the flow of feedwater to the steam generator.

For example an actual flow lower than the set-point will result in a positive error signal, which will increase the valve opening, and hence allow more feedwater to flow into the steam generator.

▶▶ 14. STEAM GENERATOR LEVEL - ONE ELEMENT CONTROL

▶▶ (1) Level Control

- level error is the difference between the level set-point and the actual (measured) level
- an actual level below the set-point results in a positive error, which will increase the valve opening

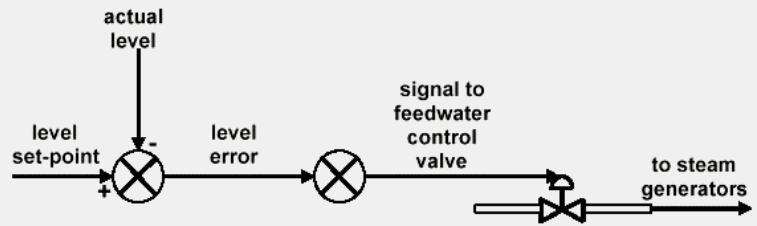

▶▶ (2) Flow Control

- flow error is the difference between the flow set-point and the actual (measured) flow
- an actual flow lower than the set-point will result in a positive error signal, which will increase the valve opening

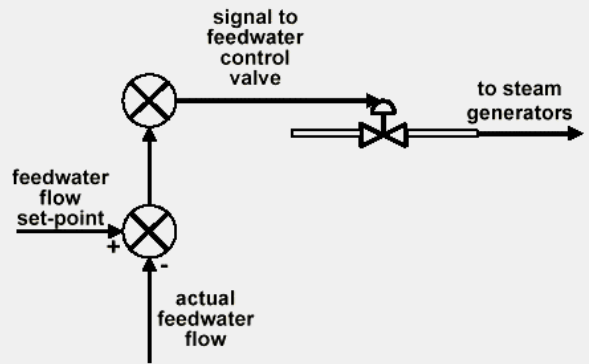

15. STEAM GENERATOR LEVEL - THREE ELEMENT CONTROL

Three element control of steam generator level involves the three process measurements that principally affect the volume of water in the steam generator. These are highlighted on the diagram: the actual steam generator level at arrow (a), the actual steam flow at arrow (b) and the actual feedwater flow at arrow (c). By “actual” I mean the measured parameter in each case.

- (1) By comparing steam flow and feedwater flow we get an indication of the flow mismatch independently of a level error.
- (2) The flow error is the difference between the steam flow and the feedwater flow.
- (3) Either a feedwater flow lower than the steam flow, or an actual level higher than the level set-point, or as long as the magnitude of a positive level error is larger than the magnitude of a negative flow error, there will be a positive error signal, which will increase the valve opening.

▶ 15. STEAM GENERATOR LEVEL - THREE ELEMENT CONTROL

- ▶ (1) by comparing steam flow and feedwater flow we get an indication of the flow mismatch independently of a level error;
- ▶ (2) the flow error is the difference between the steam flow and the feedwater flow
- ▶ (3) either a feedwater flow lower than the steam flow, or an actual level higher than the level set-point, or as long as the magnitude of a positive level error is larger than the magnitude of a negative flow error, there will be a positive error signal, which will increase the valve opening

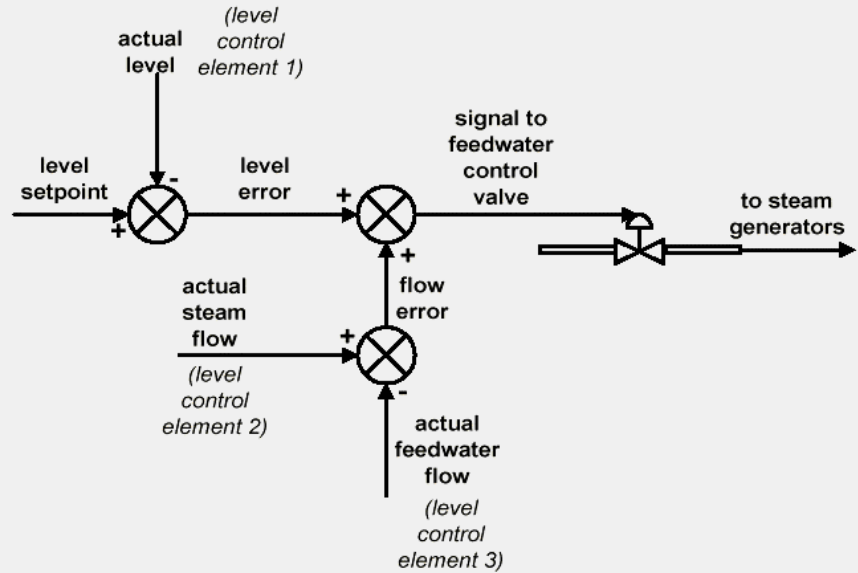

SESSION 5: ADVANCED CANDU REACTOR

MODULE CONTENTS

- [1. INTRODUCTION page 2](#)
- [2. ACR AND CANDU COMPARISON page 3](#)
- [3. KEY ACR FEATURES page 4](#)
- [4. CANFLEX-ACR FUEL page 5](#)
- [5. FUEL CHANNEL page 6](#)
- [6. ACR CALANDRIA AND FUEL CHANNELS page 7](#)
- [7. REACTIVITY MECHANISMS page 8](#)
- [8. REACTOR REGULATING SYSTEM page 9](#)
- [9. HEAT TRANSPORT SYSTEM page 10](#)
- [10. MAIN STEAM HEADER AND VALVES page 11](#)
- [11. STEAM GENERATOR FEEDWATER SYSTEMS page 12](#)
- [12. ACR OVERALL UNIT CONTROL page 13](#)



1. INTRODUCTION

This session provides an overview of the main features of the Advanced CANDU Reactor (ACR) and the design of the nuclear electric power plant that will have as its source of energy the ACR. The reference design that is considered in this session is the ACR-700, but key comparisons with the ACR-1000 will be made as appropriate. The simulator that is used to illustrate the design and operating features of the ACR is based on the 700 MWe unit size.

(1) Similarities with CANDU 6

The ACR design is based on the use of individual horizontal pressure tubes that contain the proven, simple and economical fuel bundle design and on-power fuelling. The separate, cool, low-pressure moderator continues to be heavy water, giving the ACR similar excellent neutron economies as all other CANDU reactors. The heat transport system is under pressure so that only a limited amount of boiling takes place near the outlets of the hottest channels. Heat is transferred in the steam generators that are part of a balance of plant system which is very similar to previous CANDUs.

The two independent shutdown systems (SDS) have been retained, with shutdown rods in SDS#1 and poison injection into the moderator for SDS#2.

(2) Significant new system-level features

The major innovation in ACR is the use of slightly enriched uranium fuel, and light water as the coolant, which circulates in the heat transport system. This results in a more compact reactor design and a reduction of heavy water inventory, both contributing to a significant decrease in cost compared to CANDU reactors that employ natural uranium as fuel and heavy water as coolant.

The ACR design uses higher pressures and temperatures of reactor coolant and main steam, which result in improved thermal efficiency compared to the existing CANDU plants. These thermal-hydraulic characteristics contribute significantly to improve the economics of the ACR-based generating unit.

(3) Significant new control features

In contrast to the dual digital control computer (DCC) systems used in previous CANDUs, most of the process control functions for the ACR plant are implemented using a distributed control system (DCS). The distributed control system receives and executes operator commands entered via the plant display system, and provides data acquisition for the monitoring, alarm annunciation, display and data recording functions that are performed by the plant display system.

The distributed control system is a modular digital control system, which uses a number of programmable digital controllers connected to data communication networks that have been designed to provide very high reliability and data security. The system includes comprehensive fault detection, redundancy, and switchover features, to provide a very high degree of immunity to random component failures.

- 1. INTRODUCTION
- (1) Similarities with the CANDU 6
- (2) Significant new system-level features
- (3) Significant new control features

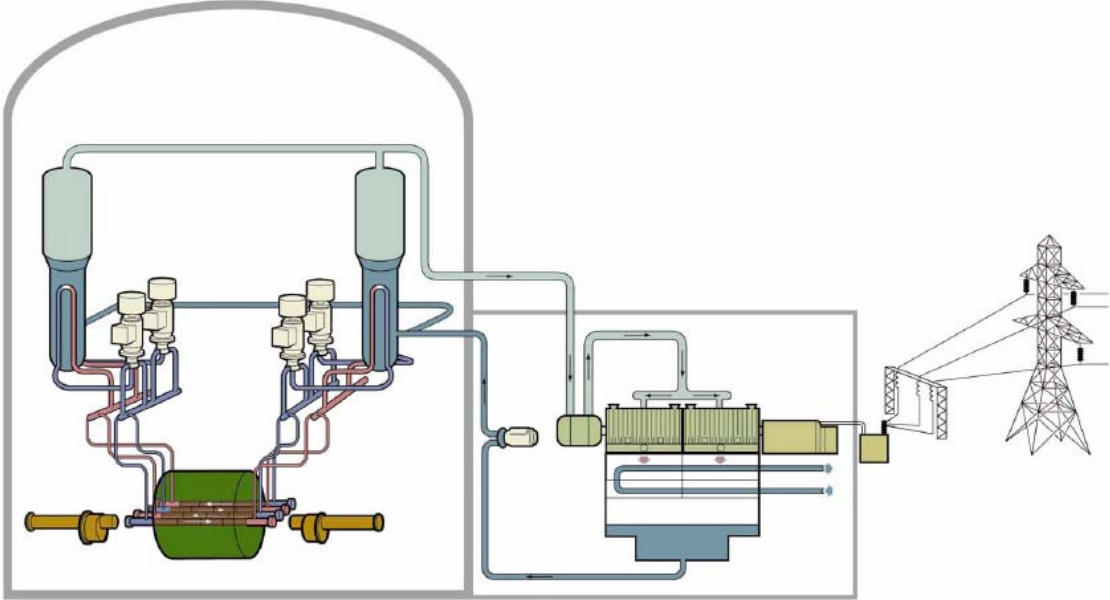

2. ACR AND CANDU COMPARISON

(1) Similar features:

The main components of the modular horizontal fuel channels are the concentric pressure and calandria tubes. These are made of the same materials as other recent CANDUs, but differ somewhat in dimensions, as we will see in section 5.

The physical arrangement of the fuel design follows the 43 element CANFLEX configuration, that retains the outside dimensions and other detailed features of the 50 cm long CANDU fuel bundle. The basis of this relatively simple design has been very successful at all previous CANDU power plants.

The heavy water moderator contained in the calandria and separated from the pressure tubes by calandria tubes remains a low pressure system, kept at temperatures only slightly above ambient conditions, that also acts as a reflector and provides a back-up heat sink to cool the fuel.

On-power refueling has been a hallmark of CANDUs, and contributes to the high capacity factors that have been demonstrated by the units during their operating life. The existing fuelling machine and fuel transfer designs can be readily adapted to the ACR.

The passive shutdown systems have been retained from earlier units, and are characterized by each system, acting alone, being 100% capable of shutting down the reactor.

To minimize the time required to gain the necessary construction and operating licenses, the well established equipment and licensing basis of previous CANDUs has been followed.

(2) Different system-level features

A key and distinguishing feature of the ACR is the use of slightly-enriched uranium (SEU) fuel, as well as having dysprosium as a burnable neutron absorber in the centre fuel element of the bundle to reduce the coolant void reactivity during postulated accidents. An average enrichment of 2.1% by weight U-235 is used for the fuel pellets in the fuel elements of the inner, intermediate and outer rings. This allows for operations at extended burn-up conditions and to compensate for the loss of reactivity due to the use of the burnable absorber material in the centre fuel element. All previous CANDUs used natural uranium, but the new design has a very low negative void coefficient, it allows higher critical heat flux, and permits increased operating and safety margins of the reactor.

The use of SEU fuel results in a more compact reactor design that leads to a reduction of heavy water inventory, with corresponding savings in construction and operating costs. Further savings result from replacing heavy water with light water as the reactor coolant. Such a configuration was not possible while natural uranium was used as fuel.

Further improvements in plant equipment configuration became possible as a result of the above changes, such as the reduction of steam generators from the previous low of four to only two in the ACR-700 design.

The use of SEU fuel allows increased thickness of pressure tubes, which in turn leads to higher heat transport system temperatures. The consequences are higher operating pressures and temperatures on the secondary side, and significant improvements in the unit's thermal efficiency.

The smaller reactor core not only saves on the cost of heavy water, but also manufacturing, shipping and construction costs.

2. ACR AND CANDU COMPARISON

▶ → (1) Similar features:

- Modular horizontal fuel channels
- Simple fuel bundle design
- Cool, low pressure heavy water moderator
- On-power fuelling
- Passive shutdown systems
- Established equipment and licensing basis

▶ → (2) Different system-level features

- Slightly-enriched uranium (SEU)
- Improved core characteristics
- Light water as reactor coolant
- Optimized plant arrangement
- Higher thermal efficiency
- Enhanced passive safety
- Smaller reactor core

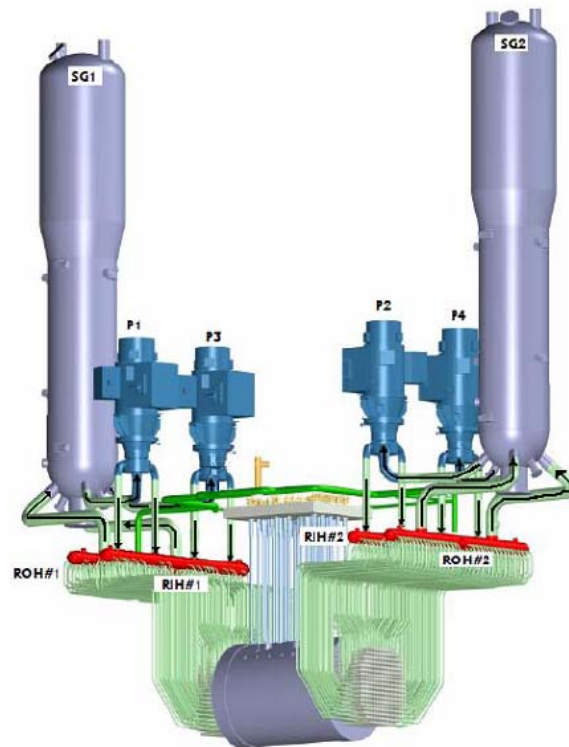

3. KEY ACR FEATURES

A typical power block of the two-unit plant layout is shown in the diagram. The layout and buildings are designed to minimize the footprint and achieve a short, practical construction schedule. The arrangements of the main structures within the reactor building, reactor auxiliary building, and turbine building of each unit are essentially identical. The individual units of the two-unit plant share control, maintenance, administration, services areas, and some common process systems. The ACR-700 two-unit integrated plant is self-sufficient, containing all the facilities required for day-to-day operations.

- (1) For the ACR-700 the nominal gross electrical output of the reference generator is 753 MWe and the estimated unit service power load is about 50 MWe, yielding a net unit electrical output of approximately 703 MWe. The thermal power produced by the reactor and transferred to the steam generators is 2034 MWth.
- (2) Simple, robust advanced design with passive resistance to severe accidents assures that the ACR-700 can be licensable internationally. The primary vehicle for establishing the licensability of the design is the assurance that it can be licensed in Canada. Furthermore, the ACR-700 addresses the key requirements of the IAEA to the extent applicable and when not in conflict with the Canadian Nuclear Safety Commission's (CNSC) requirements.
- (3) The fuel design has evolved from the fuel used in the Pickering and Bruce reactors, and that used in all of the CANDU 6 reactors, to the improved CANFLEX fuel bundle already demonstrated in the CANDU 6 Pt. Lepreau reactor. It is in the form of SEU dioxide pellets, sheathed and sealed in zirconium alloy tubes. Forty-three tubes are assembled between end plates to form a fuel bundle. Each fuel channel contains 12 bundles.
- (4) The reactor consists of a set of 292 horizontally aligned fuel channels arranged in a square pitch. The fuel channels contain the fuel and the high pressure light water coolant. They are mounted in a calandria vessel containing the heavy water moderator. Individual calandria tubes surround each individual fuel channel.

The calandria vessel is enclosed by endshields, which support each end of the calandria. They are filled with shielding balls and water to provide shielding. The fuel channels are located by adjustable restraints on the two endshields and are connected by individual feeder pipes to the Heat Transport System.

The calandria vessel is enclosed in a concrete vault (calandria vault) filled with light water for shielding. The calandria vault is closed at the top by the reactivity mechanisms deck.

3. KEY ACR FEATURES

- (1) Reference unit sizes: 700 or 1100 MWe net
- (2) Simple, robust advanced design with passive resistance to severe accidents
- (3) Fuel design: improved CANFLEX-ACR
- (4) Reference core with reactor face design optimized for operations:
lattice pitch of 245 mm enhances on-face
maintainability and inspection

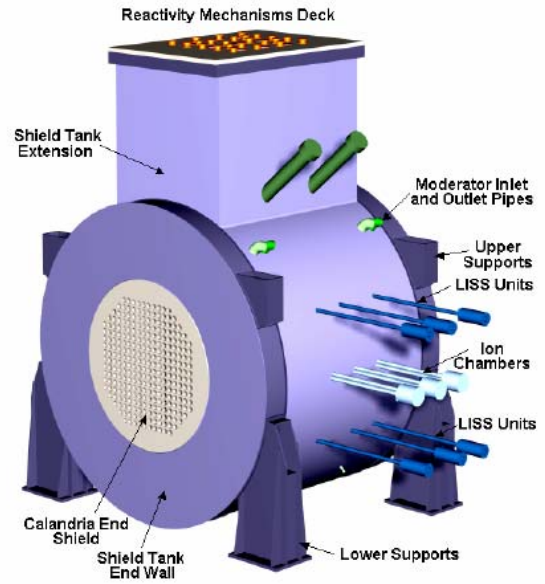
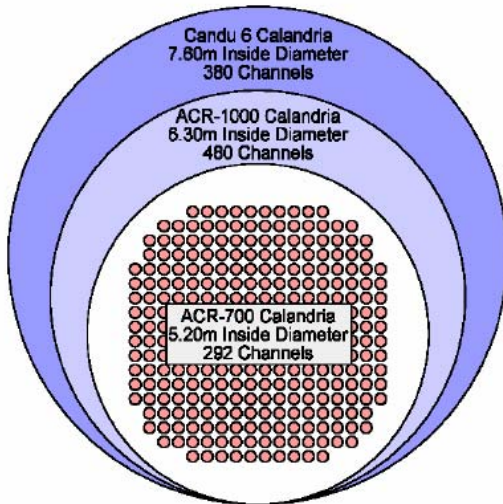

4. CANFLEX-ACR FUEL

- (1) The 43-element CANDU 6 CANFLEX Mk 4 fuel bundle forms the basis for the ACR bundle design. The bundle includes 2 different element sizes.
- (2) The centre and inner ring consist of eight elements with a diameter of 13.5 mm. The center pin contains burnable poison (U, Dy)O₂ pellet with 7.5% wt Dysprosium in natural Uranium. The inner ring has enriched uranium pellets with an average enrichment of 2.1% by weight U-235.
- (3) The outer two rings consist of 35 elements with a smaller, 11.5 mm diameter, and just like the inner ring, contain 2.1% by weight U-235.
- (4) Significantly improved CHF margins and lower linear element ratings allow the fuel to be used to increase channel power, resulting in better optimization of the core.
- (5) Much higher fuel burn-ups can be achieved relative to natural uranium. The expected burn-up in the ACR is 20,000MWd/tU, which is 2.8 times the burn-up of natural Uranium fuel in CANDU 6, typically 7,500 MWd/tU. Apart from lower fuel costs, the ACR will produce considerably less volume of spent fuel.
- (6) The ACR-700 requires about 6 new fuel bundles per full power day. This requires fuelling approximately 3 fuel channels using a 2-bundle-shift fuelling scheme.



4. CANFLEX-ACR FUEL

- (1) 43 fuel elements in one CANFLEX fuel bundle, with elements of two sizes.
- (2) The centre pin, plus an inner ring of seven elements, all with a diameter of 13.5 mm.
 - The center pin contains burnable poison (U, Dy)O₂ pellet with 7.5% wt Dysprosium in natural Uranium.
 - The inner, as well as the two outer rings, contain 2.1 % wt U-235
- (3) The outer two rings consist of 35 elements with 11.5 mm diameter.
- (4) Significantly improved CHF margin
- (5) Much higher fuel burn-up
- (6) Daily refuelling is typically two bundles in each of three channels

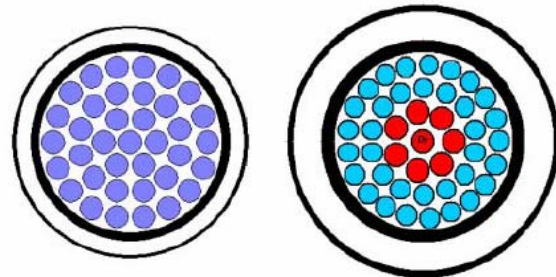

CANDU BUNDLE
(37-Elements)
CANDU - 6 Fuel Channel

CANFLEX BUNDLE
(43-Elements)
ACR Fuel Channel

5. FUEL CHANNEL

The reactor for the ACR-700 consists of 292 fuel channels arranged on a square pitch of 220 mm. Each fuel channel consists of a zirconium/niobium alloy pressure tube, which is surrounded by a zirconium alloy calandria tube with a gas gap in between. The pressure tube is separated from the calandria tube by a set of garter springs placed at strategic locations along the channel. The calandria tubes are fixed at each end to the cylindrical calandria. The diagram shows a detailed view of a typical fuel channel assembly.

- (1) Each channel operates with twelve Canflex fuel bundles, which are replaced on-power at a rate that compensates for reactivity loss due to fission product build-up in the core.
- (2) The fewer channels and tighter lattice pitch result in a much more compact core. The inside diameter of the ACR Calandria at 5.2 metres is 31.6 % less than that for a CANDU 6 Calandria, which is 7.6 metres.
- (3) The diagram illustrates the significant reduction in lattice pitch, from 286 mm in the natural uranium fuelled CANDUs to only 220 mm in the ACR-700 lattice. At the same time, the outside diameters of the pressure tubes and calandria tubes have increased. The overall effect is a large reduction in Moderator volume to Fuel volume ratio from 16.4 to 7.1.
- (4) The average channel power has increased from 5.3 MW in CANDU 6 to 6.8 MW in the ACR, while peak channel power has increased by less than 10 %.

→ 5. FUEL CHANNEL

- (1) 12 Canflex fuel bundles per channel.
- (2) Reactor core configuration with 292 fuel channels.
- (3) More compact core. Calandria inside diameter 31.6 % less than that for CANDU 6 Calandria
- (4) Average channel power increased from 5.3 MW (CANDU 6) to 6.8 MW, while peak channel power increases by less than 10 %.

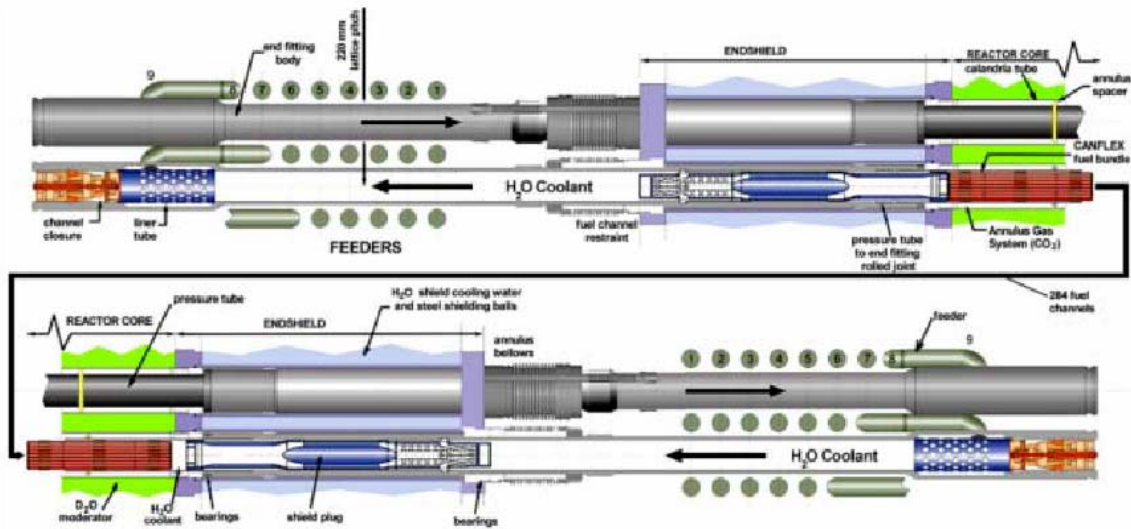

6. ACR CALANDRIA AND FUEL CHANNELS

Similarly to CANDU 6, the ACR reactor assembly comprises a cylindrical structure, the calandria assembly, within a water-filled, carbon steel-lined concrete structure, the calandria vault, as well as the fuel channel assemblies, and reactivity control units. The calandria vault is built of ordinary concrete, and is filled with light water. The water serves both as a thermal shield and as a cooling medium.

The ACR reactor design retains the small diameter horizontal fuel channels that contain high pressure, high temperature heat transport system coolant. This allows the use of a separate low pressure moderator system in which the reactivity control devices operate.

(1) Calandria assembly

The calandria assembly of the ACR is similar to that of CANDU 6, but of smaller size. It comprises the calandria vessel, two end shields, two end shield supports, two embedment rings and internal piping for end shield and vault cooling. This assembly forms a multi-compartment structure which supports and contains the fuel channel assemblies, reactivity control units, heavy water moderator and reflector, demineralised light water, carbon steel balls, and plate shielding.

The calandria assembly, including the calandria tubes, has a target operating life of 60 years at a lifetime plant capacity factor of 90%.

(2) Calandria tubes

The calandria tubes span the calandria shell horizontally on a 220 mm square pitch to form a circular lattice array. The calandria tubes are in-core components, and form a part of the calandria vessel pressure boundary.

(3) Pressure tubes

Each pressure tube is surrounded by a calandria tube, the two being held concentric by bearings at both ends, located in the end shield lattice tubes, supplemented by annulus spacers positioned at approximately one-metre intervals along the length. The space between the tubes is filled with the annulus gas (carbon dioxide) that insulates the hot pressure tube from the relatively cold moderator, thereby improving thermal efficiency.

(4) End shields

Two end shields are integral parts of the calandria assembly, one end shield being welded to each end of the calandria. Each end shield is composed of lattice tubes (292), one shell, and two tubesheets, namely the calandria tubesheet and the fuelling tubesheet.

The calandria tubesheet is common to both the end shield and the calandria. It is exposed to heavy water moderator on the calandria side, and to a flow of cooling light water on the end shield side. The balance of the end shield consists of the fuelling tubesheet (which faces the fuelling machine vault), the end shield shell, and the lattice tubes. The lattice tubes are concentric to the pressure tubes and are joined to the tubesheets.

(5) Thimbles and guides

Tubular thimbles, which separate the calandria vault light water from the moderator heavy water and cover gas, provide access for the reactivity control units into the calandria. Absorber guides for the reactivity control units penetrate the calandria, passing between the calandria tubes and locking into locators on the opposite wall of the calandria shell.

6. ACR CALANDRIA AND FUEL CHANNELS

- (1) Calandria assembly
- (2) Calandria tubes
- (3) Pressure tubes
- (4) End shields
- (5) Thimbles and guides

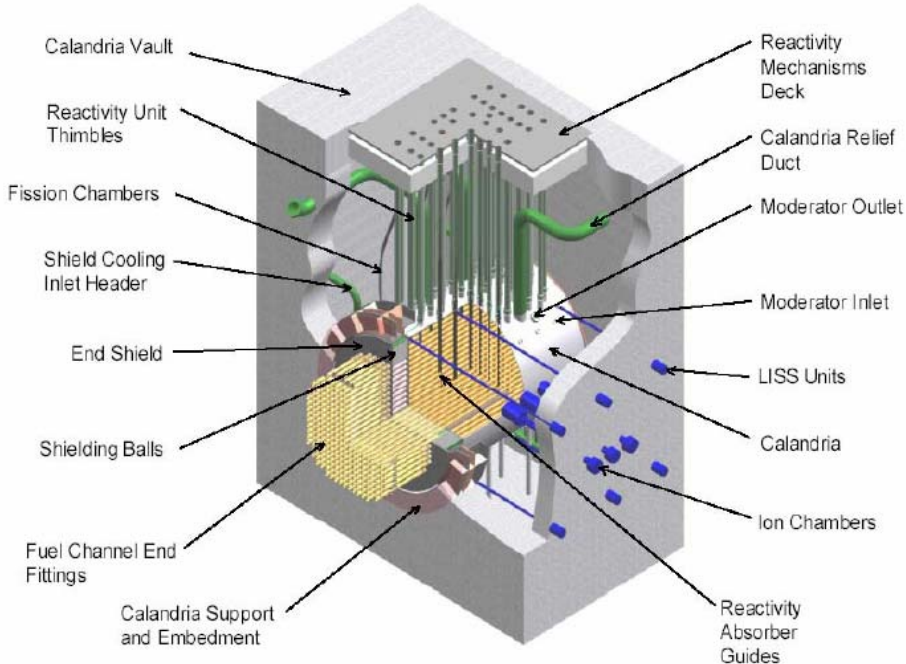

7. REACTIVITY MECHANISMS

The layout of the reactivity mechanisms deck and the horizontal reactivity control units are shown in the diagram. Reactivity control units include the neutron flux measuring devices, the zone control units and control absorber units that are used for regulating reactor power, and the shutoff units for shutdown system 1, and a liquid gadolinium injection system for shutdown system 2.

(1) Control Absorber Units

Eight control absorbers are mounted vertically and adjust the flux level at times when greater reactivity rate or depth is required than that provided by the zone control system. They use boron carbide as the neutron absorbing material. The diagram shows the locations of these units, as seen from the top of the reactor.

The absorber elements are normally motored down on command from the Reactor Regulating System. They can also be dropped when a rapid reduction in reactivity is required. The motor design allows insertion and withdrawal speeds to be varied within a predetermined range to suit plant needs.

(2) Zone Control Units

There are nine zone control units (ZCUs) with one absorber unit in each of the upper and lower halves of the reactor. The reactor is divided into 18 zones, 9 each in the upper and lower halves of the reactor. The units are arranged symmetrically in the reactor in three rows of three, with the middle row located on the reactor's axial centreline. An independently controlled absorber element is assigned to each zone for local power regulation. Control of local and bulk power is accomplished by adjusting the position of each absorber element in its assigned zone under the control of the reactor regulating system computer. Each zone control unit covers two zones and consists of two absorber elements suspended by wire ropes, a vertically oriented guide shared by the two absorber elements, and a drive mechanism to support and position the absorber element.

The absorber elements are rectangular in cross-section. A connection is provided at the top of each absorber element for the attachment of the multi-strand wire rope that it is supported by.

Each absorber guide can accommodate two independently controlled absorber elements in parallel guide ways. The bottom of each guide extends down into a thimble running off the bottom of the calandria to provide a place for the lower absorber element to be withdrawn to when not needed in the reactor.

The drive mechanism provides for independent control of each of the two absorber elements it supports in a common housing. The wire ropes connecting it to the absorber elements are wound onto a pair of sheaves inside the drive mechanism. Each sheave is independently driven by an electric motor through a self-locking gear train, allowing the absorber elements to be moved up and down on command.

(3) SDS#1 Shutoff Units

There are 24 shutoff units in the ACR-700. Just like the control absorbers, they use boron carbide as the neutron absorbing material. Because of the smaller core size, no spring is required to accelerate the rods into the core, they are dropped under the influence of gravity only.

- 7. REACTIVITY MECHANISMS
- (1) Control Absorber Units
- (2) Zone Control Units
- (3) SDS#1 Shutoff Units
- (4) SDS#2 Injection Nozzles
- (5) Vertical Flux Detector Units

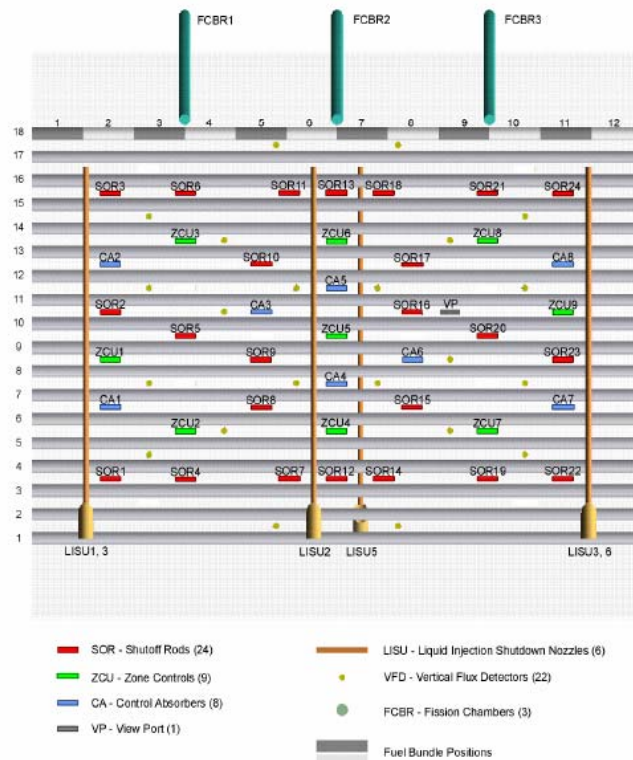

(4) SDS#2 Injection Nozzles

As in the case of CANDU 6, these units are part of shutdown system #2, and can quickly terminate reactor operation. The physical dimensions are again different from CANDU 6, due to the different calandria dimensions. Reactor shutdown is accomplished by injecting a neutron absorbing liquid (“poison”) into the heavy water moderator between the calandria tubes in the calandria.

The liquid injection shutdown system is comprised of six liquid injection shutdown units, six pressure vessels containing a gadolinium nitrate solution, a helium supply tank, a mixing tank, valves, and piping.

(5) Vertical Flux Detector Units

Several vertical and horizontal in-core flux detector units are installed in the reactor. The vertical flux detector units extend down from the reactivity mechanisms deck into the reactor. The horizontal flux detector units extend through the reactor vault wall in the liquid injection shutdown system equipment room into the reactor.

Platinum clad vertical flux detector elements, that are similar in function but different in length from the ones in CANDU 6, provide flux data to the RRS to control the zone control units in each of the eighteen zones. Additionally, a large number of vanadium flux detectors on the vertical units provide inputs to the flux mapping routine. The vertical flux detector units also have elements that provide inputs to SDS1. The horizontal platinum flux detector units provide inputs to SDS2.

8. REACTOR REGULATING SYSTEM

The Reactor Regulating System (RRS) of the ACR, as shown in the general block diagram, is essentially the same as for CANDU 6, except for the change in zone control from liquid to solid rods, and the corresponding elimination of Adjuster Rods. The following description is included to encourage course participants to review the diagram (which shows some reactor regulating features more clearly than earlier illustrations), and to review RRS in the ACR configuration.

(1) Power measurement

The power measurement and calibration routine uses measurements from a variety of sensors (self-powered in-core flux detectors, fission chambers, process instrumentation) to arrive at calibrated estimates of bulk and zonal reactor power.

(2) Demand power routine

The demand power routine computes the desired reactor power setpoint and compares it with the measured bulk power to generate a bulk power error signal that is used to operate the reactivity devices.

(3) Reactivity control devices

The primary reactivity control devices are the 18 zone control absorber elements (configured as nine units each containing two absorber elements). The zone control absorber element insertions are varied in unison for bulk power control, or differentially for tilt control.

(4) Reactor power setpoint calculation

In the "Turbine Leads" mode of operation the reactor power setpoint is calculated by the steam generator pressure control program. In the "Reactor Leads" mode of operation the reactor power setpoint is set by the operator, or, in the case of abnormal plant conditions requiring power reductions, is automatically calculated by the RRS program.

(5) Stepback and Setback

In addition to controlling reactor power to a specified setpoint, the reactor regulating system monitors a number of important plant variables, and reduces the reactor power when any of these variables exceed specified limits. This power reduction may be fast (stepback), or slow (setback), depending on the possible consequences of the variable lying outside its normal operating range.

8. REACTOR REGULATING SYSTEM

- (1) Power measurement
- (2) Demand power routine
- (3) Reactivity control devices
- (4) Reactor power setpoint calculation
- (5) Stepback and Setback

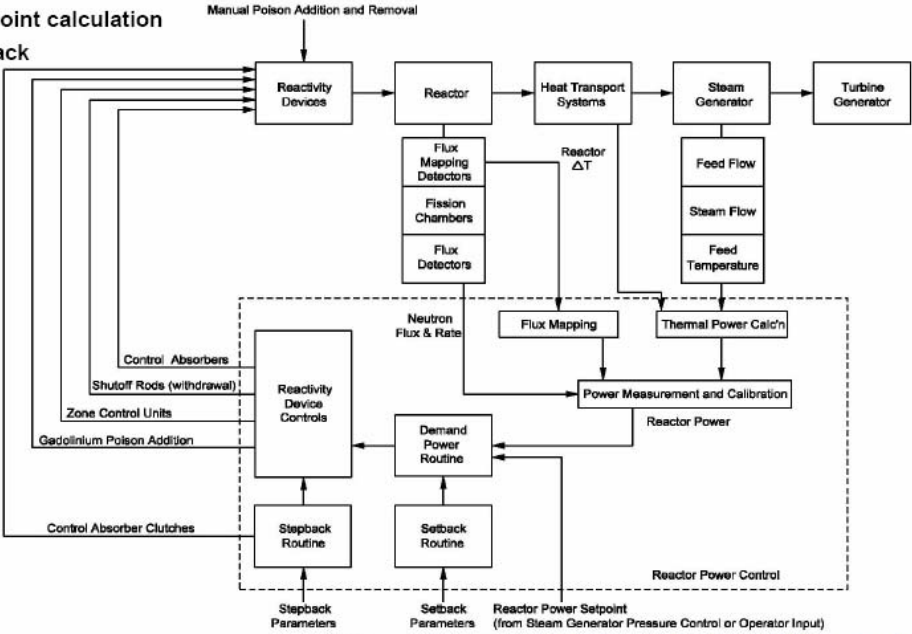

9. HEAT TRANSPORT SYSTEM

The key difference in the ACR heat transport system, relative to all previous CANDUs, is the use of ordinary water, instead of heavy water. Not only does this reduce the capital cost of the plant in direct savings of the cost of heavy water, but it leads to many simplifications, such as eliminating the need for collection and upgrading of heat transport heavy water. There are corresponding operation and maintenance savings. The headers, steam generators and pumps are located above the reactor to provide thermosyphoning if power is lost to the heat transport pumps, as in previous designs.

(1) Single figure of eight main circuit

There are two pumps, one steam generator, an inlet header and an outlet header, located at each end of the reactor. The bottom of each steam generator has two inlet pipes that connect to the reactor outlet header. Each steam generator also has two outlets that are connected to the suction line of two heat transport pumps. Each heat transport pump has double discharge pipes that connect to the reactor inlet header. Each inlet header supplies coolant flow to the inlets of the fuel channels located at each end of the reactor via individual feeder pipes.

The coolant flow is in the figure-of-eight loop configuration used in the CANDU 6 plant, with the heat transport pumps in series and the coolant making two core passes. The equipment arrangement results in bi-directional coolant flow through the core. The headers and feeders are arranged so that 50 percent of the fuel channels are served by each inlet header and are uniformly distributed throughout the core. The headers, steam generators and pumps are all located above the reactor.

The pressure in the reactor outlet headers is controlled by a pressurizer connected to the reactor outlet header at one end of the reactor.

The two reactor outlet headers are interconnected to assure flow stability in the HTS. The interconnect line is equipped with two restriction orifices to optimize the effectiveness of the interconnect line.

(2) Two steam generators

Two identical steam generators with integral preheaters transfer heat from the reactor coolant on the steam generator primary side to raise the temperature of, and boil, feedwater on the steam generator secondary side. The steam generator consists of an inverted vertical U-tube bundle installed in a shell. Steam-separating equipment is housed in the upper portion of the shell. A steam generator is shown in the diagram, and can be seen to be similar in shape to the ones used in previous CANDUs, but having its dimensions optimized for the ACR-700 system parameters.

(3) Four main circuit pumps

The four heat transport pumps are vertical, single stage centrifugal pumps with single suction and double discharge. A typical heat transport pump is shown in the diagram.

Each pump is driven by a vertical, totally enclosed, air-to-water cooled squirrel cage induction motor. The motor has built-in inertia to prolong pump rundown on loss of power.

- 9. HEAT TRANSPORT SYSTEM
- (1) Single figure of eight main circuit
- (2) Two steam generators
- (3) Four main circuit pumps
- (4) Two inlet and two outlet headers

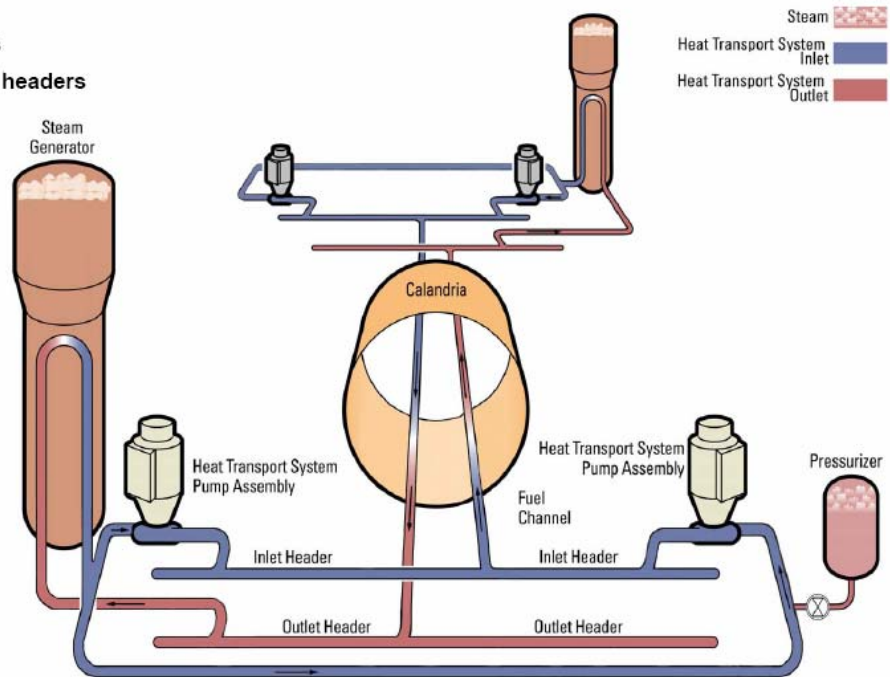

(4) Two inlet and two outlet headers

There are two reactor outlet headers, one at each end of the reactor. Each of the reactor outlet headers receives the flow from the outlet feeders on one reactor face and conducts the flow to two steam generator inlet lines, which lead to a single steam generator.

There are two reactor inlet headers, one at each end of the reactor. Each of the reactor inlet headers receives the flow from two heat transport pumps through four discharge lines and channels the flow to the inlet feeders on one reactor face. The ACR-700 reactors are designed for reactor inlet header operating temperature value of about 280°C.

10. MAIN STEAM HEADER AND VALVES

The main steam lines supply steam from the two steam generators in the reactor building to the turbine through the steam balance header at a constant pressure. Also at the outlet nozzles of each steam generator, venturi flow restrictors are installed to reduce the main steam line break pressure inside the Reactor Building containment. The required steam generator level is controlled by varying the feedwater flow to each steam generator, as in CANDU 6. Steam generator pressure is also controlled in a manner similar to CANDU 6. Condenser steam discharge valves and the atmospheric steam discharge valves, as well as main steam safety valves are provided for pressure protection of the steam generator secondary side. Main steam isolation valves are provided to limit blowdown to one steam generator in the event of a steam line break to limit containment pressure and also to isolate the main steam supply to the turbine in the event of steam generator tube leak, after reactor shutdown when the long term cooling system is placed in service and the heat transport system is depressurized.

(1) Steam Generator

Two identical steam generators with integral preheaters transfer heat from the reactor coolant on the steam generator primary side to raise the temperature of, and boil, feedwater on the steam generator secondary side. The steam generator consists of an inverted vertical U-tube bundle installed in a shell. Steam-separating equipment is housed in the upper portion of the shell. A steam generator is shown in the diagram.

(2) Main Steam Header

Steam is produced in the two steam generators and fed into four separate steam mains, which pass through the reactor building wall and are routed to the turbine building where they connect to the main steam header.

(3) Main Steam Supply Lines

One main steam isolation valve is installed on each steam line, downstream of the main steam safety valves and upstream of the atmospheric steam discharge valve, to isolate the steam generators for certain postulated scenarios involving main steam line breaks and steam generator tube leaks.

(4) Control Valves

Condenser steam discharge valves are also provided to discharge live steam to the turbine condenser and discharge steam during severe transients, such as loss of line or turbine trip, so as to avoid activating the main steam safety valves. Atmospheric steam discharge valves are used to control steam generator pressure and to provide a heat sink when the main condenser is either unavailable or inadequate.

(5) Safety Valves

Main steam safety valves are provided in each steam main to protect the steam generators from overpressure and to remove heat from the fuel during accident conditions.

- 10. MAIN STEAM HEADER AND VALVES
- (1) Steam Generator
- (2) Main Steam Header
- (3) Main Steam Supply Lines
- (4) Control Valves
- (5) Safety Valves

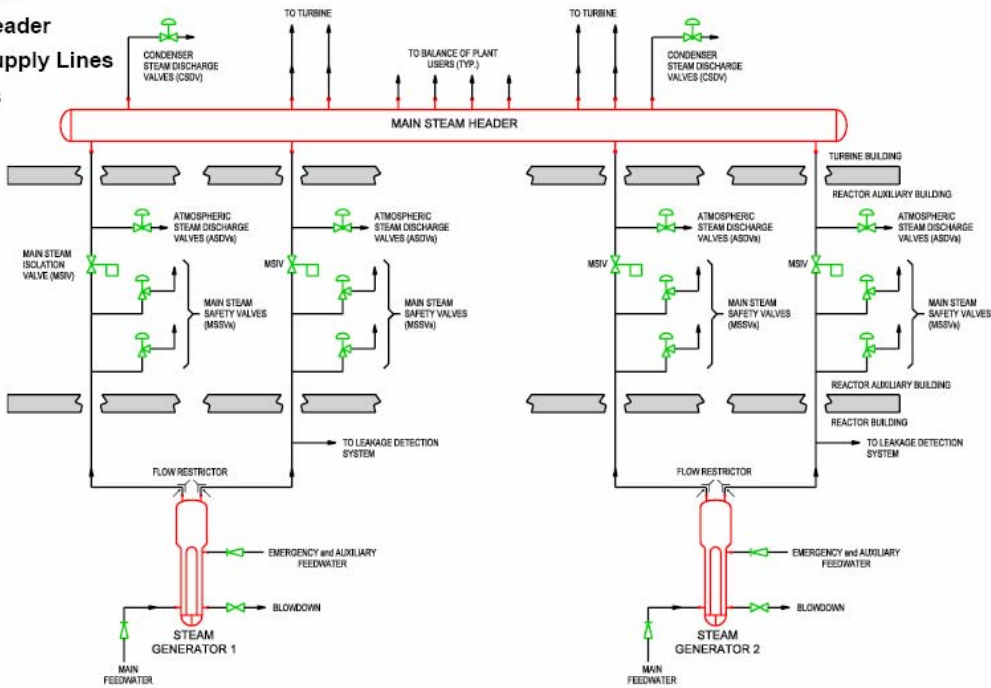

11. STEAM GENERATOR FEEDWATER SYSTEMS

The feedwater system takes hot, pressurized feedwater from the feedwater train and discharges the feedwater into the preheater section of the steam generators. As shown in the diagram, the Feedwater system is similar to that of CANDU 6, the main difference being that there are only two steam generators, and that the secondary side operates at higher steam pressures and temperatures. Thermodynamic optimization of the feedheating system is done at each site, taking into consideration the characteristics of the site and the condenser cooling system.

(1) Feedwater

The feedwater is demineralized and preheated light water. The feedwater piping carries the feedwater from the deaerator through the steam generator feed pumps, high pressure feedwater heaters, and the feedwater control valves, to the steam generators.

(2) Feedwater mains

Two feedwater mains run from the turbine building into the reactor building. Each main connects to one steam generator. Each feedwater main is equipped with a swing check valve located on the steam generator platform. This valve prevents back flow of feedwater out of the steam generator on a loss of feedwater supply.

(3) Feedwater control valves

Two 110% feedwater control valves with isolating valves are provided in each feedwater main. A smaller control valve is provided in parallel with the main feedwater control valves and is used during low flow operation. Flow elements measure feedwater flow rate to each steam generator. Flow measurement is required for gross power determination and for steam generator level control.

(4) Emergency feedwater

If normal feedwater to the steam generators is unavailable, the reserve water system provides emergency water coolant to the steam generators for long term decay heat removal. Supply line to each steam generator is provided for this purpose. A check valve in each line prevents backflow and circulation between steam generators during normal plant operation.

11. STEAM GENERATOR FEEDWATER SYSTEMS

- (1) Feedwater
- (2) Feedwater mains
- (3) Feedwater control valves
- (4) Emergency feedwater

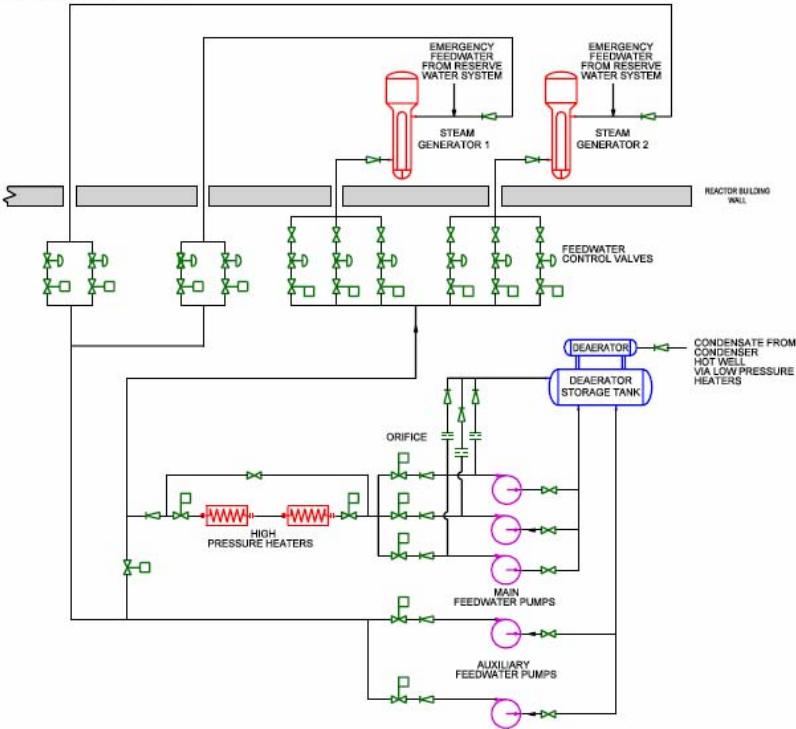

12. ACR OVERALL UNIT CONTROL

Overall Unit Control (OUC) of the ACR, as shown in the diagram, is essentially the same as for CANDU 6. The following description is included to encourage course participants to review the diagram (which shows some overall unit control features more clearly than earlier illustrations), and to review OUC in the ACR configuration.

(1) Warmup operation

Warmup of the HTS is controlled by the steam generator pressure control program from any temperature. The warmup rate is set by the operator. The cooldown proceeds in the same way as warmup until the temperature is below 177°C, at which stage the long term cooling system can take over. During warmup, the reactor power is adjusted according to steam generator pressure error, as in the “Turbine Leads” mode, but uses a feed forward term based on the desired temperature rate instead of the turbine load. Alternatively, the operator can place the setpoint in the “Reactor Leads” mode and request a steady reactor power level known to give approximately the rate of warmup desired.

(2) Cooldown operation

Cooldown proceeds in much the same way, except that reactor power is not involved. The reactor is shut down when cooldown is initiated. Cooldown would normally make use of the condenser steam discharge valves. The discharge capacity of the valves is approximately proportional to steam generator pressure and, as this pressure decreases during cooldown, progressively larger valve openings are required to maintain a given temperature rate. If the main condenser is unavailable, cooldown is possible via the atmospheric steam discharge valves, at a rate limited by the capacity of these valves.

(3) Log power operation

In the low log power ranges, the reactor power setpoint cannot be controlled from the steam generator pressure, because even a very large relative change in the reactor power will have little or no effect on steam generator pressure. In this range, reactor power calculation by RRS is based upon the measurements of neutron flux by the fission chambers. Steam generator pressure is controlled by the ASDVs and CSDVs.

(4) “Reactor Leads” mode

In the “Reactor Leads” mode of operation where the plant as a “base load” power source, reactor power is controlled to a setpoint supplied by the operator. The steam generator pressure control program then manipulates the plant loads to keep steam drum pressure constant.

(5) “Turbine Leads” mode

In the “Turbine Leads” mode at-power operation of the unit, the generator load is adjusted by suitably positioning the turbine load setpoint. The reactor power is raised or lowered to maintain steam generator pressure at its setpoint, and therefore follows generator load changes.

The turbine-generator controller changes the generator load in response to requests from the local operator or from a remote load control centre, and thereafter maintains the load at the desired setpoint except in cases of grid frequency upsets, when the action of the turbine speed governor prevails. The nuclear steam supply system will follow such governor initiated load changes through the action of the steam generator pressure controller.

- 12. ACR OVERALL UNIT CONTROL
- (1) Warmup operation
- (2) Cooldown operation
- (3) Log power operation
- (4) "Reactor Leads" mode
- (5) "Turbine Leads" mode

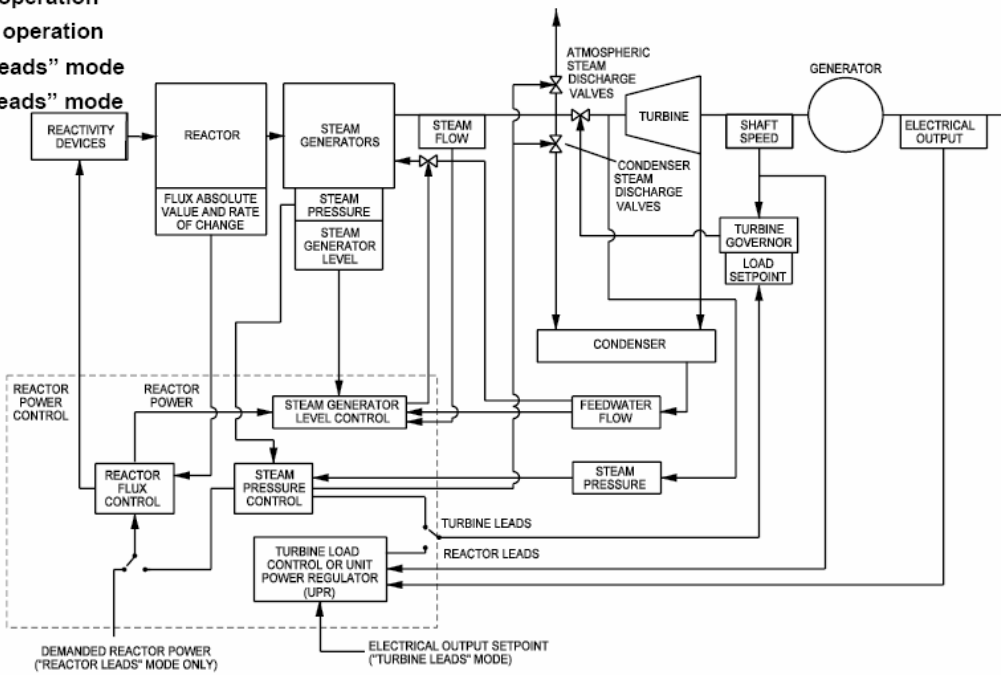

CANDU-9 COMPACT SIMULATOR

USER MANUAL

Lecture Notes

prepared by:

Dr. George Bereznai

Dean, Energy Management and
Nuclear Science, at the University of
Ontario Institute of Technology,
Canada

george.bereznai@uoit.ca

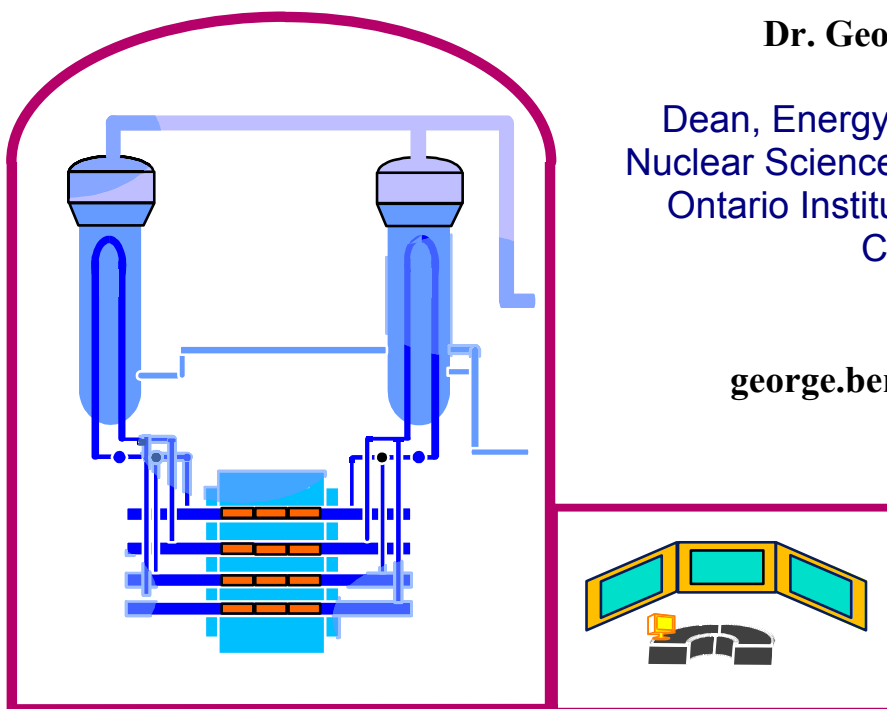

CONTENTS

1. INTRODUCTION
 - 1.1 SIMULATOR STARTUP
 - 1.2 SIMULATOR INITIALIZATION
 - 1.3 LIST OF CANDU 9 COMPACT SIMULATOR DISPLAY SCREENS
 - 1.4 COMPACT SIMULATOR DISPLAY COMMON FEATURES
2. SIMULATOR DISPLAY PAGES
 - 2.1 PLANT OVERVIEW PAGE
 - 2.2 SHUTDOWN RODS PAGE
 - 2.3 REACTIVITY CONTROL PAGE
 - 2.4 PHT MAIN CIRCUIT
 - 2.5 PHT FEED AND BLEED
 - 2.6 PHT INVENTORY CONTROL
 - 2.7 PHT PRESSURE CONTROL
 - 2.8 BLEED CONDENSER CONTROL
 - 2.9 STEAM GENERATOR FEED PUMPS PAGE
 - 2.10 STEAM GENERATOR LEVEL CONTROL PAGE
 - 2.11 STEAM GENERATOR LEVEL TRENDS PAGE
 - 2.12 STEAM GENERATOR LEVEL MANUAL.
 - 2.13 EXTRACTION STEAM PAGE CONTROL
 - 2.14 TURBINE GENERATOR PAGE
 - 2.15 RRS / DPR PAGE
 - 2.16 UPR PAGE
 - 2.17 TREND

1. INTRODUCTION

The CANDU-9 Compact Simulator was originally developed to assist Atomic Energy of Canada Limited (AECL) in the design of the plant display system. The specification for the Simulator required that the software be capable of execution on a Personal Computer (Pentium 100 or equivalent), to operate essentially in real time, and to have a dynamic response with sufficient fidelity to provide realistic signals to the plant display system. The Simulator also had to have a user-machine interface that mimicked the actual control panel instrumentation, including the plant display system, to a degree that permitted the development and operation of the simulator in a stand-alone mode, i.e. in the absence of the plant display system equipment. These features also made the Simulator suitable as an educational and training tool.

The minimum hardware configuration for the Simulator consists of an IBM compatible Personal Computer, 16 Mbytes RAM with 256 external Cache, at least 0.5 Mbytes enhanced IDE hard drive, 2 Mbytes VRAM, hi-resolution video card (capable of 1024x768), 15 inch or larger high resolution SVGA colour monitor, keyboard and mouse. The operating system is Windows for Workgroups 3.11 or Windows 95.

The requirement of having a single PC to execute the models and display the main plant parameters in real time on a high resolution monitor implied that the models had to be as simple as possible, while having realistic dynamic response. The emphasis in developing the simulation models was on giving the desired level of realism to the user. That meant being able to display those plant parameters which are most critical to operating the unit, including the ones that characterize the main process, control and protective systems. The current configuration of the Simulator is able to respond to the operating conditions normally encountered in power plant operations, as well as to many malfunctions conditions, as summarized in Table 1.

The simulation uses an on object oriented approach: basic models for each type of device and process to be represented are developed in FORTRAN. These basic models are a combination of first order differential equations, logical and algebraic relations. The appropriate parameters and input-output relationships are assigned to each model as demanded by a particular system application.

The interaction between the user and the Simulator is via a combination of monitor displays, mouse and keyboard. Parameter monitoring and operator controls implemented via the plant display system at the generating station are represented in a virtually identical manner on the Simulator. Control panel instruments and control devices, such as push-buttons and hand-switches, are shown as stylized pictures, and are operated via special pop-up menus and dialog boxes in response to user inputs.

This Operating Manual assumes that the user is familiar with the main characteristics of thermal nuclear power plants, as well as understanding the unique features of the CANadian Deuterium Uranium(CANDU) reactors.

Table 1: Summary of Simulator Features.

SYSTEM	SIMULATION SCOPE	DISPLAY PAGES	OPERATOR CONTROLS	MALFUNCTIONS
REACTOR	<ul style="list-style-type: none"> neutron flux levels over a range of 0.001 to 110% full power, 6 delayed neutron groups decay heat (3 groups) all reactivity control devices xenon and boron poison reactor regulating system reactor shutdown system 	<ul style="list-style-type: none"> reactivity control devices shutdown rods reactor regulating system 	<ul style="list-style-type: none"> reactor power and rate of change (input to control computer) manual control of reactivity devices reactor trip reactor setback reactor stepback 	<ul style="list-style-type: none"> reactor setback and stepback fail one bank of control rods drop into the reactor
HEAT TRANSPORT	<ul style="list-style-type: none"> two phase main circuit loop with four pumps, four steam generators, four equivalent reactor coolant channels pressure and inventory control (pressurizer, degasser condenser, feed & bleed control, pressure relief) operating range is zero power hot to full power 	<ul style="list-style-type: none"> main circuit pressure control pressurizer control feed and bleed control inventory control degasser condenser control 	<ul style="list-style-type: none"> circulating pumps pressurizing pumps pressurizer pressure pressurizer level degas cond. pressure degas cond. level feed & bleed bias isolation valves for: pressurizer, degasser cond., feed and bleed 	<ul style="list-style-type: none"> main circuit relief valve fails open pressurizer relief valve fails open pressurizer isolation valve fails closed feed valve fails open bleed valve fails open reactor header break
STEAM & FEEDWATER	<ul style="list-style-type: none"> boiler dynamics, including shrink and swell effects steam supply to turbine and reheater turbine by-pass to condenser steam relief to atmosphere extraction steam to feed heating steam generator pressure control steam generator level control boiler feed system 	<ul style="list-style-type: none"> steam generator feed pumps steam generator level control steam generator level trends steam generator pressure control extraction steam 	<ul style="list-style-type: none"> level controller mode: computer or manual manual level control gain & reset time level control valve selection level control isolation valve opening extraction steam valves feed pump operation 	<ul style="list-style-type: none"> all level control isolation valves fail closed one level control valve fails open one level control valve fails closed all feed pumps trip all safety valves open steam header break flow transmitter fails
TURBINE-GENERATOR	<ul style="list-style-type: none"> very simple turbine model mechanical power and generator output are proportional to steam flow speeder gear and governor valve allow synchronized and non-synchronized operation 	<ul style="list-style-type: none"> turbine-generator 	<ul style="list-style-type: none"> turbine trip turbine run-back turbine run-up and synchronization atmospheric and condenser steam discharge valves 	<ul style="list-style-type: none"> turbine spurious trip turbine spurious run-back
OVERALL UNIT	<ul style="list-style-type: none"> fully dynamic interaction between all simulated systems unit power regulator unit annunciation computer control of all major system functions 	<ul style="list-style-type: none"> overall unit unit power regulator 		

1.1 SIMULATOR STARTUP

- select program 'CANDU-9' for execution
- click anywhere on 'CANDU-9 Compact Simulator' screen
- click 'OK' to 'Load Full Power IC?'
- the Simulator will display the 'Plant Overview' screen with all parameters initialized to 100% Full Power
- at the bottom right hand corner click on 'Run' to start the simulator

1.2 SIMULATOR INITIALIZATION

If at any time you need to return the Simulator to one of the stored Initialization Points, do the following:

- 'Freeze' the Simulator
- click on 'IC'
- click on 'Load IC'
- click on 'FP_100.IC' for 100% full power initial state
- click 'OK' to 'Load C:\AECL_P2\FP_100.IC'
- click 'YES'
- click 'Return'
- Start the Simulator operating by selecting 'Run'.

1.3 LIST OF CANDU 9 COMPACT SIMULATOR DISPLAY SCREENS

1. Plant Overview
2. Shutdown Rods
3. Reactivity Control
4. PHT Main Circuit
5. PHT Feed & Bleed
6. PHT Inventory Control
7. PHT Pressure Control
8. Bleed Condenser Control
9. Steam Generator Feed Pumps
10. Steam Generator Level Control Steam
11. Generator Level Trends
12. Steam Generator Level Manual Ctrl
13. Extraction Steam
14. Turbine Generator
15. RRS / DPR
16. UPR



IAEA PHWR Simulator[©]

Generic CANDU Model

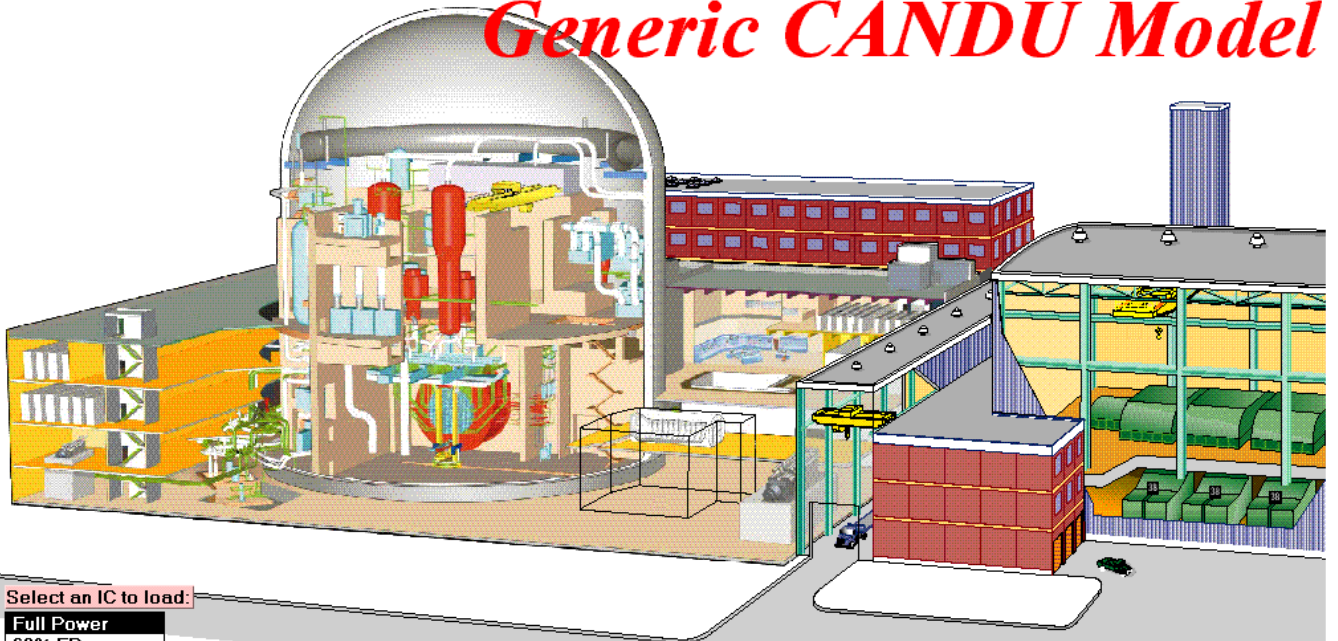

Courtesy of AECL

Select an IC to load:

- Full Power
- 68% FP
- 10% FP
- Zero Power Hot
- Other...

Click anywhere to continue
with the selected IC...

IC Filename:

FP_100.IC

Produced by

Cassiopeia Technologies Inc.

About ...

1.4 COMPACT SIMULATOR DISPLAY COMMON FEATURES

The CANDU 9 Compact Simulator is made up of 16 interactive display screens or pages. All of these screens have the same information at the top and bottom of the displays, as follows:

- top of the screen contains 21 plant alarms and annunciations; these indicate important status changes in plant parameters that require operator actions; each of these alarms will be discussed as part of the system that is generating it and/or is involved in the corrective action;
- top right hand corner shows the simulator status:
 - ⇒ the window under 'Labview' (this is the proprietary software that generates the screen displays) has a counter that is incrementing when Labview is running; if Labview is frozen (i.e. the displays cannot be changed) the counter will not be incrementing;
 - ⇒ the window displaying 'CASSIM' (this is the proprietary software that computes the simulation responses) will be green and the counter under it will not be incrementing when the simulator is frozen (i.e. the model programs are not executing), and will turn red and the counter will increment when the simulator is running;
- to stop (freeze) Labview click once on the 'STOP' sign at the top left hand corner; to restart 'Labview' click on the ⇒ symbol at the top left hand corner;
- to start the simulation click on 'Run' at the bottom right hand corner; to 'Stop' the simulation click on 'Freeze' at the bottom right hand corner;
- the bottom of the screen shows the values of the following major plant parameters:
 - ⇒ Reactor Neutron Power (%)
 - ⇒ Reactor Thermal Power (%)
 - ⇒ Generator Output (%)
 - ⇒ Main Steam Header Pressure (kPa)
 - ⇒ Steam Generator Level (m)
 - ⇒ OUC Mode ('Normal' or 'Alternate')
- the bottom left hand corner allows the initiation of two major plant events:
 - ⇒ 'Reactor Trip'
 - ⇒ 'Turbine Trip'

these correspond to hardwired push buttons in the actual control room;

- the box above the Trip buttons shows the display currently selected (i.e. 'Plant Overview'); by clicking and holding on the arrow in this box the titles of the other displays will be shown, and a new one can be selected by highlighting it;
- the remaining buttons in the bottom right hand corner allow control of the simulation one iteration at a time ('Iterate'); the selection of initialization points ('IC'); insertion of malfunctions ('Malf'); and calling up the 'Help' screen.

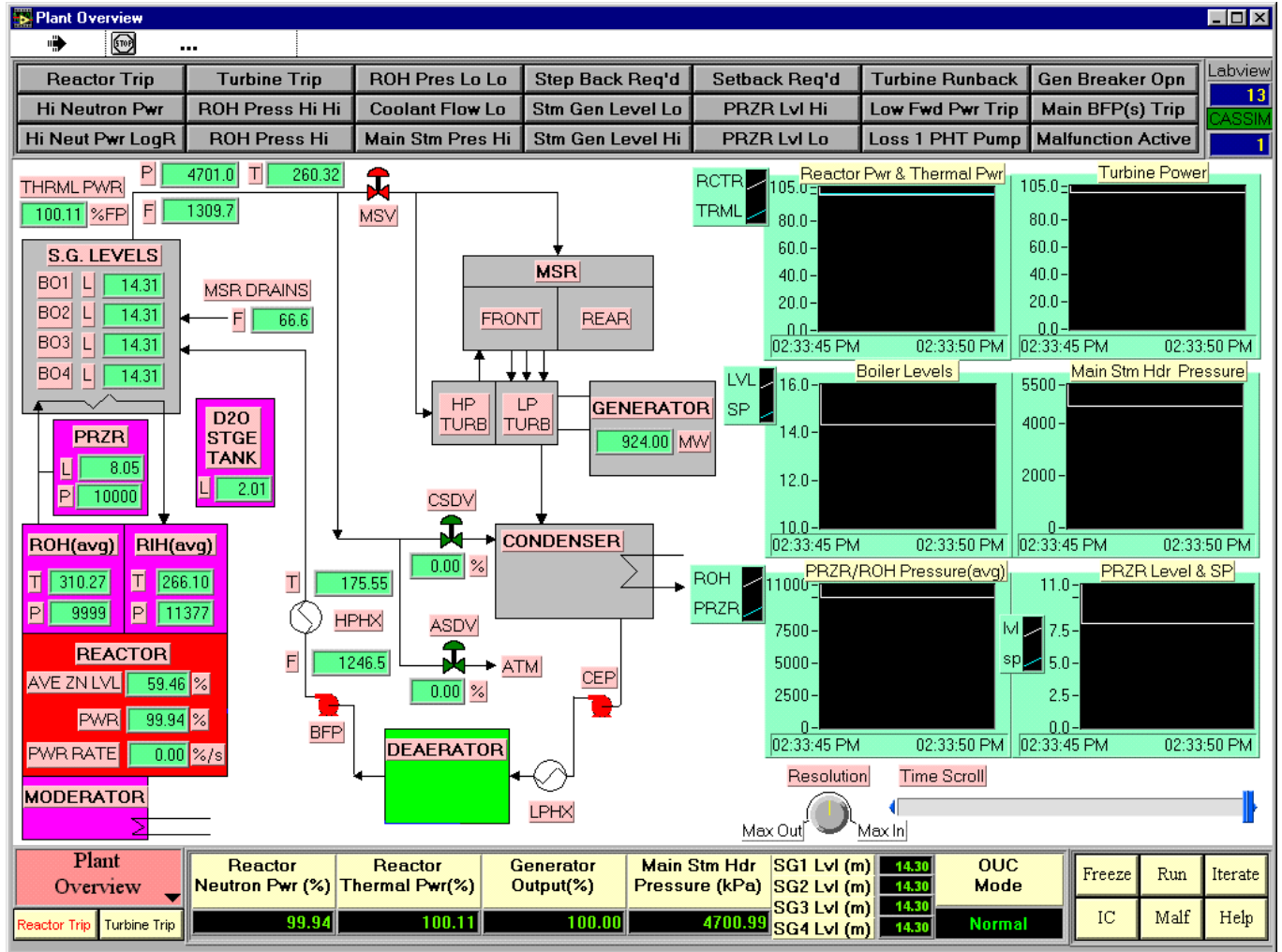

2. SIMULATOR DISPLAY PAGES

2.1 PLANT OVERVIEW PAGE

Shows a 'line diagram' of the main plant systems and parameters. No inputs are associated with this display. The systems and parameters displayed are as follows (starting at the bottom left hand corner):

- MODERATOR system is not simulated
- REACTOR is a point kinetic model with six groups of delayed neutrons, the decay heat model uses a three group approximation; reactivity calculations include reactivity control and safety devices, Xenon, voiding in channels and power level changes. The parameters displayed are:
 - ⇒ Average Zone Level (% full)
 - ⇒ Neutron Power (% full power)
 - ⇒ Neutron Power Rate (%/ second)
- Heat Transport main loop, pressure and inventory control systems are shown as a single loop on the Plant Overview display, additional details will be shown on subsequent displays. The parameters displayed are:
 - ⇒ Reactor Outlet Header (ROH) and Reactor Inlet Header (RIH) average Temperature (°C) and Pressure (kPa)
 - ⇒ Pressurizer Level (m) and Pressure (kPa); D₂O Storage Tank level (m)
- The four Steam Generators are individually modeled, but only the level measurements are shown separately, for the flows, pressures and temperatures average values are shown. The parameters displayed are:
 - ⇒ Boiler 1, 2, 3, 4 Level (m)
 - ⇒ Steam Flow (kg/sec)
 - ⇒ Steam Pressure (kPa)
 - ⇒ Steam Temperature (°C)
 - ⇒ Moisture Separator and Reheater (MSR) Drains Flow (kg/sec)
 - ⇒ Status of control valves is indicated by their colour: green is closed, red is open; the following valves are shown for the Steam System:
 - Main Steam Stop Valves (MSV) status only
 - Condenser Steam Discharge Valves (CSDV) status and % open
 - Atmospheric Steam Discharge Valves (ASDV) status and % open
- Generator output (MW) is calculated from the steam flow to the turbine
- Condenser and Condensate Extraction Pump (CEP) are not simulated
- Simulation of the feedwater system is very much simplified; the parameters displayed on the Plant Overview screen are:
 - ⇒ Total Feedwater flow to the steam generators (kg/sec)
 - ⇒ Average Feedwater temperature after High Pressure Heater (HPHX)
 - ⇒ Status of Boiler Feed Pumps (BFP) is indicated as red if any pumps are 'ON' or green if all the pumps are 'OFF'

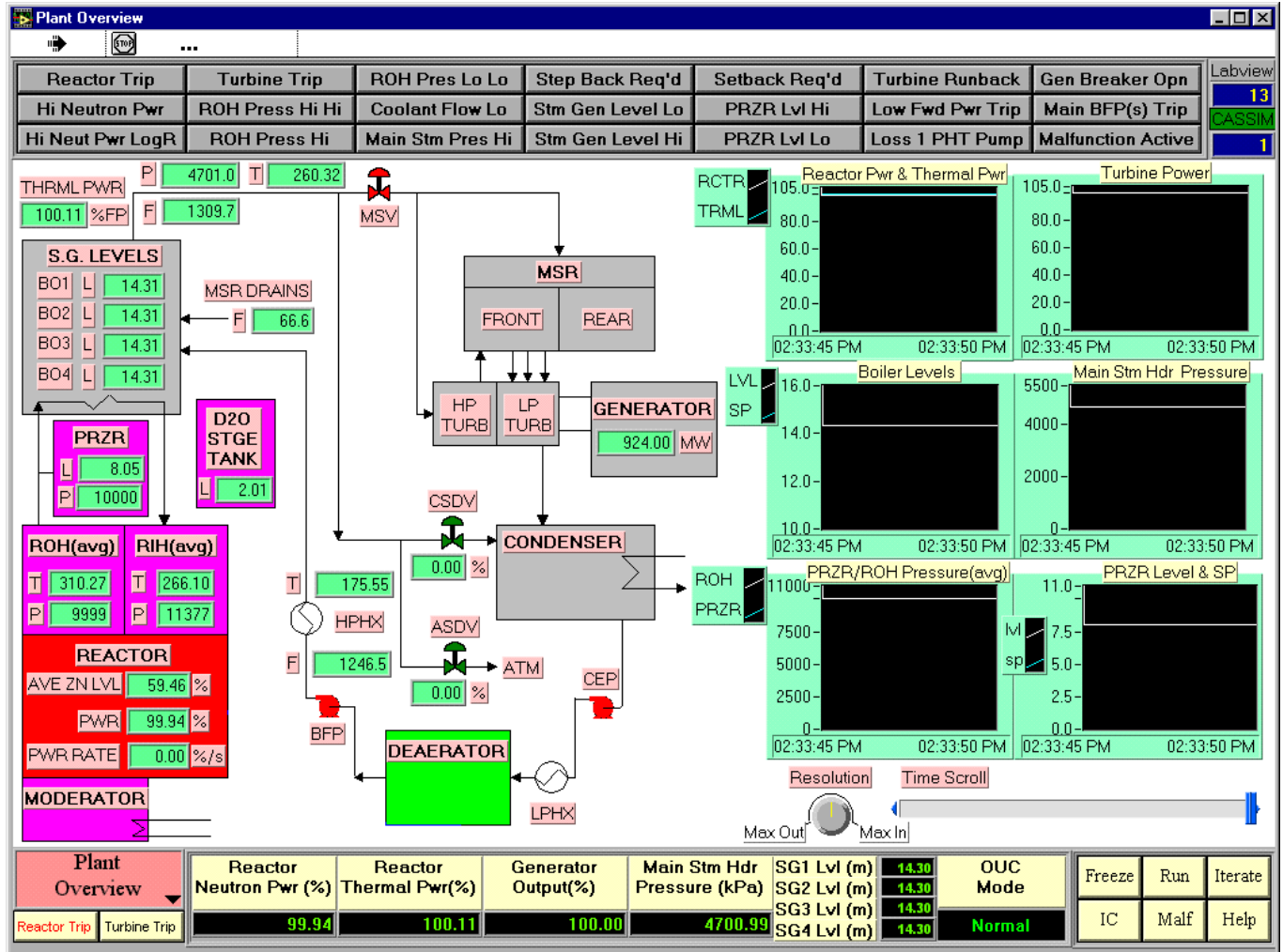

Six trend displays show the following parameters:

- Reactor Neutron Power and Reactor Thermal Power (0-100%)
- Turbine Power (0-100%)
- Boiler Levels - actual and setpoint (m)
- Main Steam Header Pressure (kPa)
- Pressurizer and Reactor Outlet Header (average) Pressure (kPa)
- Pressurizer Level - actual and setpoint (m)

Note that while the simulator is in the 'Run' mode, all parameters are being continually computed and all the displays are available for viewing and inputting changes.

2.2 SHUTDOWN RODS PAGE

The screen shows the status of SDS#1, as well as the reactivity contributions of each device and physical phenomenon that is relevant to reactor operations.

- The positions of each of the two SDS1 SHUTDOWN ROD banks are shown relative to their normal (fully withdrawn) position.
- REACTOR TRIP status is shown as NO (green) or YES (yellow), the trip can be reset here (as well as on the RRS / DPR page); note that SDS1 RESET must also be activated before RRS will begin withdrawing the Shutdown Rods.
- The REACTIVITY CHANGE of each device and parameter from the initial 100% full power steady state is shown, as well as the range of its potential value.
 - ⇒ Note that reactivity is a computed not a measured parameter, it can be displayed on a simulator but is not directly available at an actual plant.
 - ⇒ Note also that when the reactor is critical the Total reactivity must be zero.

Shutdown Rods

Reactor Trip	Turbine Trip	ROH Pres Lo Lo	Step Back Req'd	Setback Req'd	Turbine Runback	Gen Breaker Opn	Labview
Hi Neutron Pwr	ROH Press Hi Hi	Coolant Flow Lo	Stm Gen Level Lo	PRZR Lvl Hi	Low Fwd Pwr Trip	Main BFP(s) Trip	8
Hi Neut Pwr LogR	ROH Press Hi	Main Stm Pres Hi	Stm Gen Level Hi	PRZR Lvl Lo	Loss 1 PHT Pump	Malfunction Active	CASSIM
							1

SDS1 SHUTDOWN RODS STATUS

BANK 1

BANK 2

REACTOR TRIP

NO

SDS1 RESET

Reactor Pwr & Thermal Pwr

Liquid Zone Delta mK

Total Delta mK

Absorber Rods Delta mK

Xenon Delta mK

Adjuster Rods Delta mK

Resolution Time Scroll

Max Out Max In

Shutdown Rods		Reactor Neutron Pwr (%)	Reactor Thermal Pwr(%)	Generator Output(%)	Main Stm Hdr Pressure (kPa)	SG1 Lvl (m)	SG2 Lvl (m)	SG3 Lvl (m)	SG4 Lvl (m)	OUC Mode	Freeze	Run	Iterate
Reactor Trip	Turbine Trip	99.94	100.11	100.00	4700.99	14.30	14.30	14.30	14.30	Normal	IC	Malf	Help

2.3 REACTIVITY CONTROL PAGE

This screen shows the Limit Control Diagram, and the status of the three reactivity control devices that are under the control of RRS.

- The Limit Control Diagram displays the Operating Point in terms of Power Error and Average Liquid Zone level.

POWER ERROR = ACTUAL POWER - DEMANDED POWER

- ⇒ If power error is negative, more (positive) reactivity is needed, hence liquid zone level will decrease and if this is insufficient, absorber rods and adjuster rods will be withdrawn from the reactor.
- ⇒ If power error is positive, negative reactivity is needed, hence liquid zone level will increase and if this is insufficient, absorber rods and adjuster rods will be driven into the reactor.
- ⇒ The Power Error computation includes the difference between the magnitudes and rates of change of the actual and demanded powers, each multiplied by a controller constant. The above simple formula is written only as a quick reminder of the meaning of the power error term.
- The ABSORBERS are moved in two banks, and are normally outside the core. They are moved by RRS if AUTO is selected, or can be moved manually if their control is placed into the MANUAL mode. Note that reactor power should not exceed 80%FP if either of the Control Absorbers is not fully out of the core.
- The ADJUSTERS are moved in eight banks, and are normally fully inserted into the core. They are moved by RRS if AUTO is selected, or manually if they are placed in MANUAL mode. Note that maximum reactor power should be reduced by 5%FP for each Adjuster Rod bank that is not in the fully inserted position.
- The liquid zone system is simplified on this model of the Simulator, and includes only one zone that represents all of the 14 liquid zones. The average zone level, water outflow and inflow rates are displayed. When the inlet valve is in the AUTO position, it is under the control of RRS. By selecting manual control, the opening of the inlet valve and hence the zone level can be manually controlled.
- The speed of the Absorbers and Adjusters is displayed but cannot be controlled from this page.

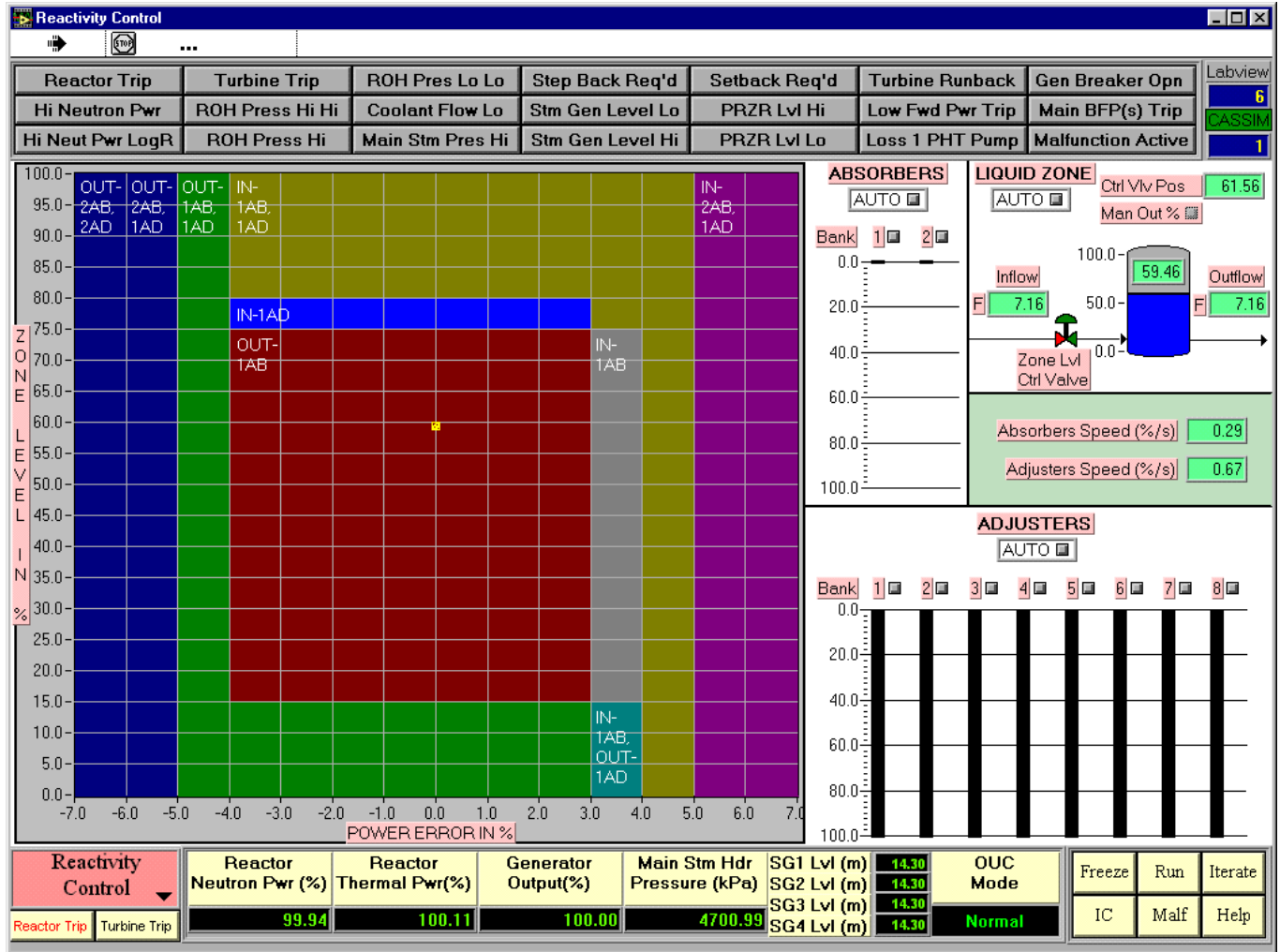

2.4 PHT MAIN CIRCUIT

This screen shows a simplified layout of the main heat transport system: the 480 coolant channels are represented by only four channels, two per loop showing the opposite directions of flow in the figure of eight configuration of each loop.

Starting from fuel channel number 1 at the reactor and following the direction of coolant flow, the system components and parameters shown are:

- average channel exit temperature (°C)
- ROH2 (note that ROH2 pressure and temperature are shown in the box below the reactor)
- SG2
- P2 (selection allows 'START', 'STOP' and 'RESET' operations)
- Pressure (kPa) and temperature (°C) at the outlet of P2
- RIH2 (note that RIH2 pressure and temperature are shown in the box below the reactor)
- fuel channel number 2
- average channel exit temperature (°C)
- ROH1 (note that ROH1 pressure and temperature are shown in the box above the reactor)
- SG1
- Feed flow into main loop (kg/sec)
- P1 (selection allows 'START', 'STOP' and 'RESET' operations)
- Pressure (kPa) and temperature (°C) at the outlet of P1
- RIH1 (note that RIH1 pressure and temperature are shown in the box above the reactor)
- flow returns to fuel channel number 1

The same equipment and parameters are shown in the lower loop, except that instead of feed flow into this loop there is bleed flow out (kg/sec).

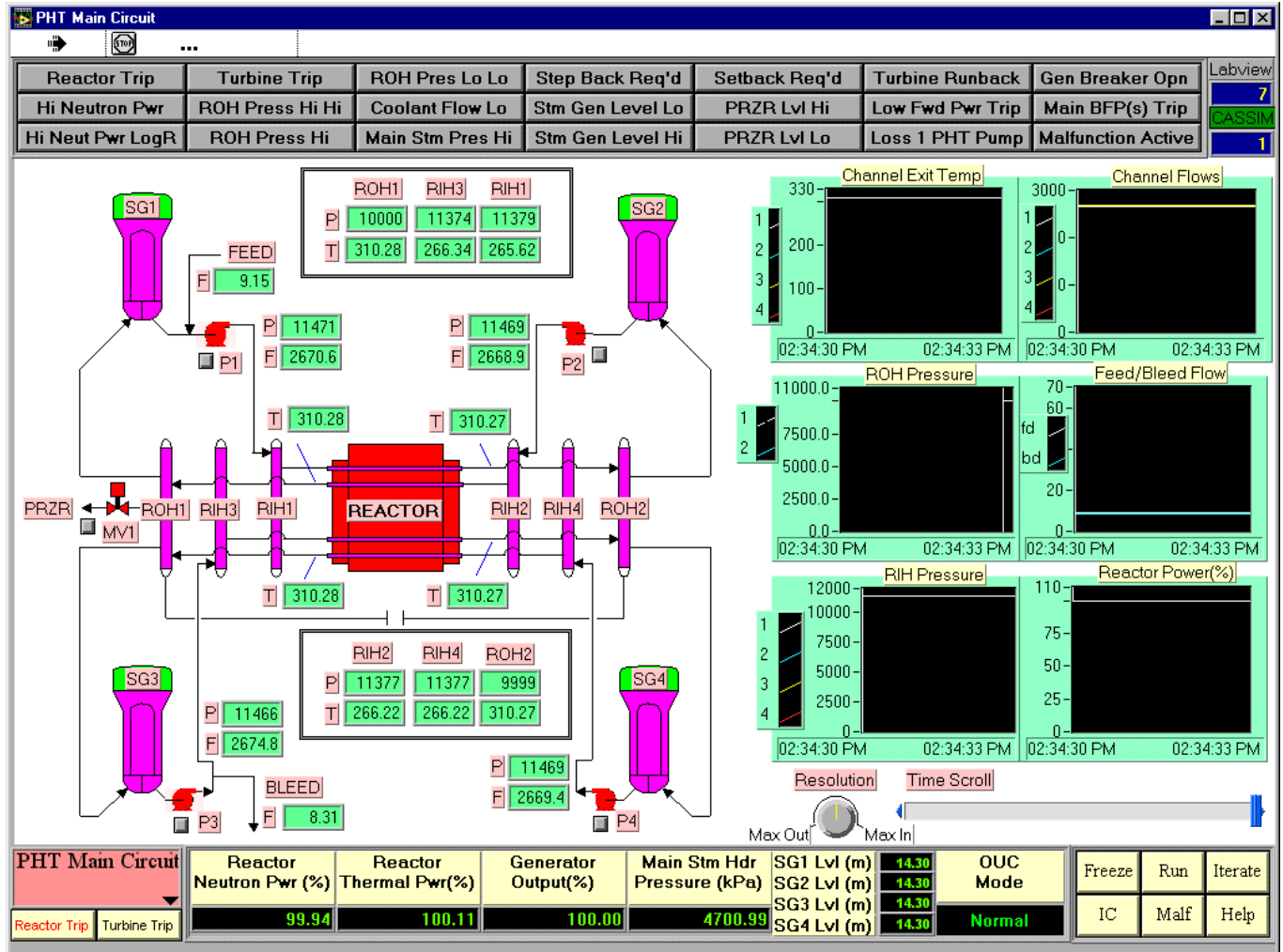

2.5 PHT FEED AND BLEED

This screen shows the Heat Transport pressure control system, including the pressurizer, bleed (or de-gasser) condenser, pressure relief, feed and bleed circuits and D2O storage tank.

- Starting with the storage tank at the bottom left hand corner, its level is displayed in meters. The tank supplies the flow and suction pressure for the Feed (or Pressuring) pumps P1 and P2: normally one pump is running, the popup menu allows START, STOP and RESET operations.
- The Flow (kg/sec) and Temperature (°C) of the feed flow are displayed. Part of the flow goes to the Bleed Condenser to provide spray cooling (via CV14, kg/sec) and reflux cooling (via CV11, kg/sec), with the reflux flow being returned to the feed line past the feed control valve CV12; the feed flow then passes through the feed isolation valve MV18 before entering the main circuit at the suction of the main circulating pump 1.
- Proceeding in an anti-clockwise direction, the Pressure (kPa) and Temperature (°C) of ROH#1 are shown. Flow from the Outlet header is normally to and from the Pressurizer via MV1, a negative flow (kg/sec) indicating flow out of the pressurizer. In case of excessive heat transport header pressure, relief valve CV20 opens and discharges flow (kg/sec) to the Bleed Condenser. Pressurizer Pressure (kPa), Temperature(°C) and Level (m) are displayed.
- Pressurizer pressure is maintained by heaters (in case the pressure falls) and by steam discharge valves CV22 and CV23 if the pressure is too high.
- Bleed Condenser pressure relief is provided via RV1. Parameters displayed for the Bleed Condenser are: Pressure (kPa), Temperature(°C) and Level (m). Feed flow from main circuit pump 3 (header pressure in kPa) flows (kg/sec) via Bleed Control valves CV5, CV6 and MV8. Bleed Condenser by-pass is via MV7.
- The outflow from the Bleed Condenser is via MV9, the Bleed Cooler and the Bleed Condenser Level Control valve CV15 to the Purification Circuit. The values of Temperature(°C) and Flow (kg/sec) into the Purification System are displayed.
- Heat Transport pressure control in NORMAL mode is via the Pressurizer; via the PHT MODE popup menu SOLID mode can be selected. PRESSURIZER LEVEL SETPOINT and ROH PRESSURE SETPOINT are also shown.

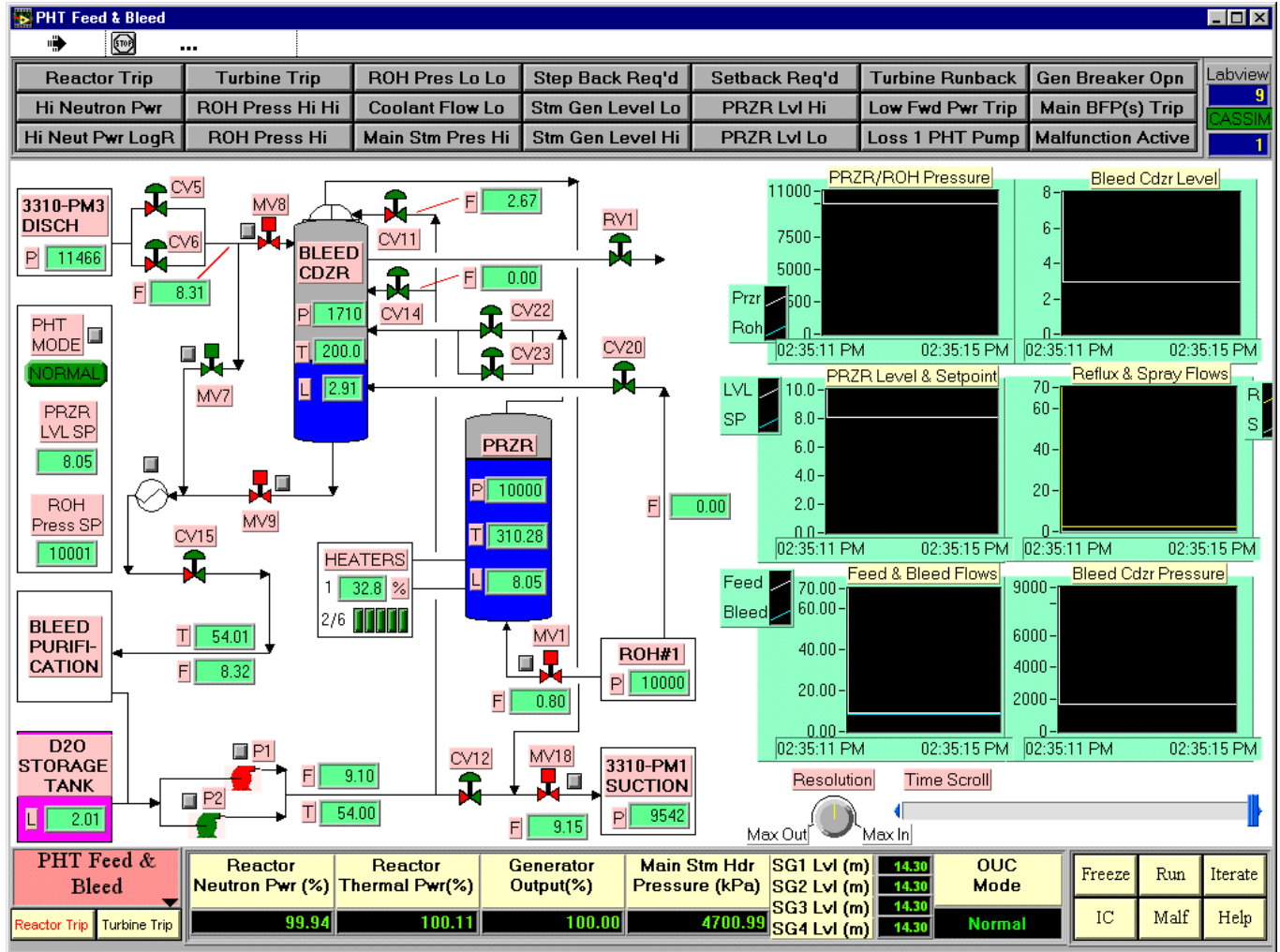

2.6 PHT INVENTORY CONTROL

The screen shows the parameters relevant to controlling the inventory in the main heat transport loop. Either NORMAL or SOLID modes of operation may be selected. Note that in NORMAL mode, inventory control is achieved by controlling Pressurizer Level, while in SOLID mode inventory control is by means of maintaining main heat transport pressure via the feed and bleed valves.

- Pressurizer Level is normally under computer control, with the setpoint being ramped as a function of reactor power and the expected shrink and swell resulting from the corresponding temperature changes. Level control may be transferred to MANUAL and the SETPOINT can then be controlled manually.
- The amount of feed and bleed is controlled about a bias value that is set to provide a steady flow of bleed to the Purification System. The amount of flow may be adjusted by changing the value of the BIAS. The positions of feed and bleed valves are normally under AUTO control, but may be changed to MANUAL using the popup menus.
- In SOLID mode the ROH PRESSURE (kPa) may be controlled manually via the popup menu.

PHT Inventory Control
Labview 22

Reactor Trip	Turbine Trip	ROH Pres Lo Lo	Step Back Req'd	Setback Req'd	Turbine Runback	Gen Breaker Opn	22
Hi Neutron Pwr	ROH Press Hi Hi	Coolant Flow Lo	Stm Gen Level Lo	PRZR Lvl Hi	Low Fwd Pwr Trip	Main BFP(s) Trip	CASSIM
Hi Neut Pwr LogR	ROH Press Hi	Main Stm Pres Hi	Stm Gen Level Hi	PRZR Lvl Lo	Loss 1 PHT Pump	Malfunction Active	1

PHT MODE

NORMAL

PHT INVENTORY CONTROL

RCTR

TRML

PRZR LEVEL CONTROL

PRZR LVL(M) 8.05 MODE AUTO

PRZR LVL SETPOINT(M) 8.05 MANUAL SETPOINT(M)

FEED/BLEED BIAS

Reflux Feed Vlv(%) AUTO POS 7.65 MAN O/P

Direct Feed Vlv(%) AUTO POS 16.59 MAN O/P

Bleed Vlv CV5(%) AUTO POS 14.50 MAN O/P BIAS 19.37

Bleed Vlv CV6(%) AUTO POS 14.50 MAN O/P

SOLID MODE ROH PRESSURE CONTROL

ROH PRESSURE 10000 KPA MAN SETPOINT 10001 KPA

Reactor Pwr & Thermal Pwr

ROH Pressure & Setpoint(Solid)

PRZR Level & Setpoint

PHT Feed/Bleed Valve Pos

Resolution Time Scroll

Max Out Max In

PHT Inventory Control		Reactor Neutron Pwr (%)	Reactor Thermal Pwr(%)	Generator Output(%)	Main Stm Hdr Pressure (kPa)	SG1 Lvl (m) 14.30	SG2 Lvl (m) 14.30	SG3 Lvl (m) 14.30	SG4 Lvl (m) 14.30	OUC Mode	Normal	Freeze	Run	Iterate
Reactor Trip	Turbine Trip	99.94	100.11	100.00	4700.99					IC	Malf	Help		

page 19

2.7 PHT PRESSURE CONTROL

This screen is similar to the previous one in terms of the ability to select PHT Pressure Control MODE and SOLID MODE ROH PRESSURE CONTROL. The difference arise in the control of Pressurizer pressure.

- The six HEATERS are normally in AUTO, with the variable Heater (#1) modulating. The other five heaters are either ON or OFF, and under AUTO control. Via the popup menus MANUAL operation can be selected, and each heater may be selected to START, STOP or RESET.
- STEAM BLEED CONTROL is via CV22 and CV23. These are normally in AUTO mode, but may be placed on MANUAL and the valve opening manually controlled via popup menus.

Reactor Trip	Turbine Trip	ROH Pres Lo Lo	Step Back Req'd	Setback Req'd	Turbine Runback	Gen Breaker Opn	Labview
Hi Neutron Pwr	ROH Press Hi Hi	Coolant Flow Lo	Stm Gen Level Lo	PRZR Lvl Hi	Low Fwd Pwr Trip	Main BFP(s) Trip	9
Hi Neut Pwr LogR	ROH Press Hi	Main Stm Pres Hi	Stm Gen Level Hi	PRZR Lvl Lo	Loss 1 PHT Pump	Malfunction Active	CASSIM
							1

PHT MODE

NORMAL

PHT PRESSURE CONTROL

RCTR

TRML

HEATERS CONTROL

1	AUTO	32.76	3	AUTO	OFF	5	AUTO	OFF
2	AUTO	OFF	4	AUTO	OFF	6	AUTO	OFF

STEAM BLEED CONTROL

CV22(%)	AUTO	POS	0.00	MAN O/P
CV23(%)	AUTO	POS	0.00	MAN O/P

SOLID MODE ROH PRESSURE CONTROL

ROH PRESSURE	10000	KPA	MAN SETPOINT	10001	KPA
--------------	-------	-----	--------------	-------	-----

Reactor Pwr & Thermal Pwr

ROH Pressure & Setpoint(Solid)

PRZR Level & Setpoint

PHT Stm Bleed Valve Pos

Resolution

Time Scroll

Max Out | Max In

PHT Pressure Control		Reactor Neutron Pwr (%)	Reactor Thermal Pwr(%)	Generator Output(%)	Main Stm Hdr Pressure (kPa)	SG1 Lvl (m)	SG2 Lvl (m)	SG3 Lvl (m)	SG4 Lvl (m)	OUC Mode	Freeze	Run	Iterate
Reactor Trip	Turbine Trip	99.94	100.11	100.00	4700.99	14.30	14.30	14.30	14.30	Normal	IC	Malf	Help

2.8 BLEED CONDENSER CONTROL

The parameters required to control Bleed Condenser Pressure and Level are shown on this screen.

- PRESSURE CONTROL is normally achieved via altering the REFLUX flow, and SPRAY flow only takes place if REFLUX flow is unable to maintain pressure control. To achieve such a split mode of operation, the SETPOINT for the Reflux valve, denoted as BLEED CONDENSER PRESSURE SETPOINT (kPa) is set at a value lower than the BLEED CONDENSER PRESSURE SETPOINT FOR SPRAY VALVE (kPa). Both valves are normally on AUTO, but may be selected to MANUAL and the valve opening controlled directly via popup menus.
- LEVEL CONTROL is normally in the AUTO mode about the specified SETPOINT. However if the BLEED TEMPERATURE AT COOLER EXIT exceeds a preset value (68°C), the control mode is switched to TEMPERATURE CONTROL mode, which restricts the valve opening so as to protect the ion exchanger resin.
- The LEVEL CONTROL VALVE may be placed on MANUAL for direct control of the valve's position.

Reactor Trip	Turbine Trip	ROH Pres Lo Lo	Step Back Req'd	Setback Req'd	Turbine Runback	Gen Breaker Opn	Labview
Hi Neutron Pwr	ROH Press Hi Hi	Coolant Flow Lo	Stm Gen Level Lo	PRZR Lvl Hi	Low Fwd Pwr Trip	Main BFP(s) Trip	11
Hi Neut Pwr LogR	ROH Press Hi	Main Stm Pres Hi	Stm Gen Level Hi	PRZR Lvl Lo	Loss 1 PHT Pump	Malfunction Active	CASSIM
							1

BLEED CONDENSER PRESSURE & LEVEL CONTROL

PRESSURE CONTROL

BLEED CDSR PRES(KPa) 1710 BLD CDSR PRES SP(KPa) 1710

REFLUX VALVE(%) AUTO POS 7.65 MAN O/P

BLD CDSR PRES SP FOR SPRAY VALVE(KPa) 1913

SPRAY VALVE(%) AUTO POS 0.00 MAN O/P

LEVEL CONTROL

BLEED CDSR LVL(M) 2.91 BLD CDSR LVL SP(M) 2.94

BLEED TMP AT COOLER EXIT(deg C) 54.01 MODE LEVEL CTRL

LEVEL CTRL VALVE(%) AUTO POS 5.84 MAN O/P

Resolution Time Scroll

Max Out Max In

Bleed Condenser Control	Reactor Neutron Pwr (%)	Reactor Thermal Pwr(%)	Generator Output(%)	Main Stm Hdr Pressure (kPa)	SG1 Lvl (m)	SG2 Lvl (m)	SG3 Lvl (m)	SG4 Lvl (m)	OUC Mode			
Reactor Trip Turbine Trip	99.94	100.11	100.00	4700.99	14.30	14.30	14.30	14.30	Normal	Freeze	Run	Iterate
										IC	Malf	Help

2.9 STEAM GENERATOR FEED PUMPS PAGE

Screen shows the portion of the feedwater system that includes the Deaerator, the boiler feed pumps, the high pressure heaters and associated valves, with the output of the HP heaters going to the Steam Generator Level Control Valves. The following parameters are displayed:

- Deaerator Level (m)
- Boiler Feedpump Suction Header Pressure (kPa)
- Boiler Feed Pump inlet valves (MV63 to MV68), outlet valves (MV13 to MV18) and associated popup menus allowing them to be opened or closed
- Main Boiler Feed Pumps (P1 to P4) and Auxiliary Boiler Feed Pumps p1 and p2 with associated popup menus for control selections
- Recirculating flow control valves FCV153, 253, 353, 453, 553, 653; pressure control valves PCV555, 565; and associated popup menus for AUTO/MANUAL selection and controller parameter tuning
- High Pressure Heaters HX5A and HX5B and popup menus to select either or both heaters to be in-service
- HP Heater isolation valves MV29 to MV32 and popup menus for open and close control
- Pressure at inlet and outlet of HP heaters (kPa)
- Flow at inlet header to Steam Generator Level Control Valves (kg/sec)

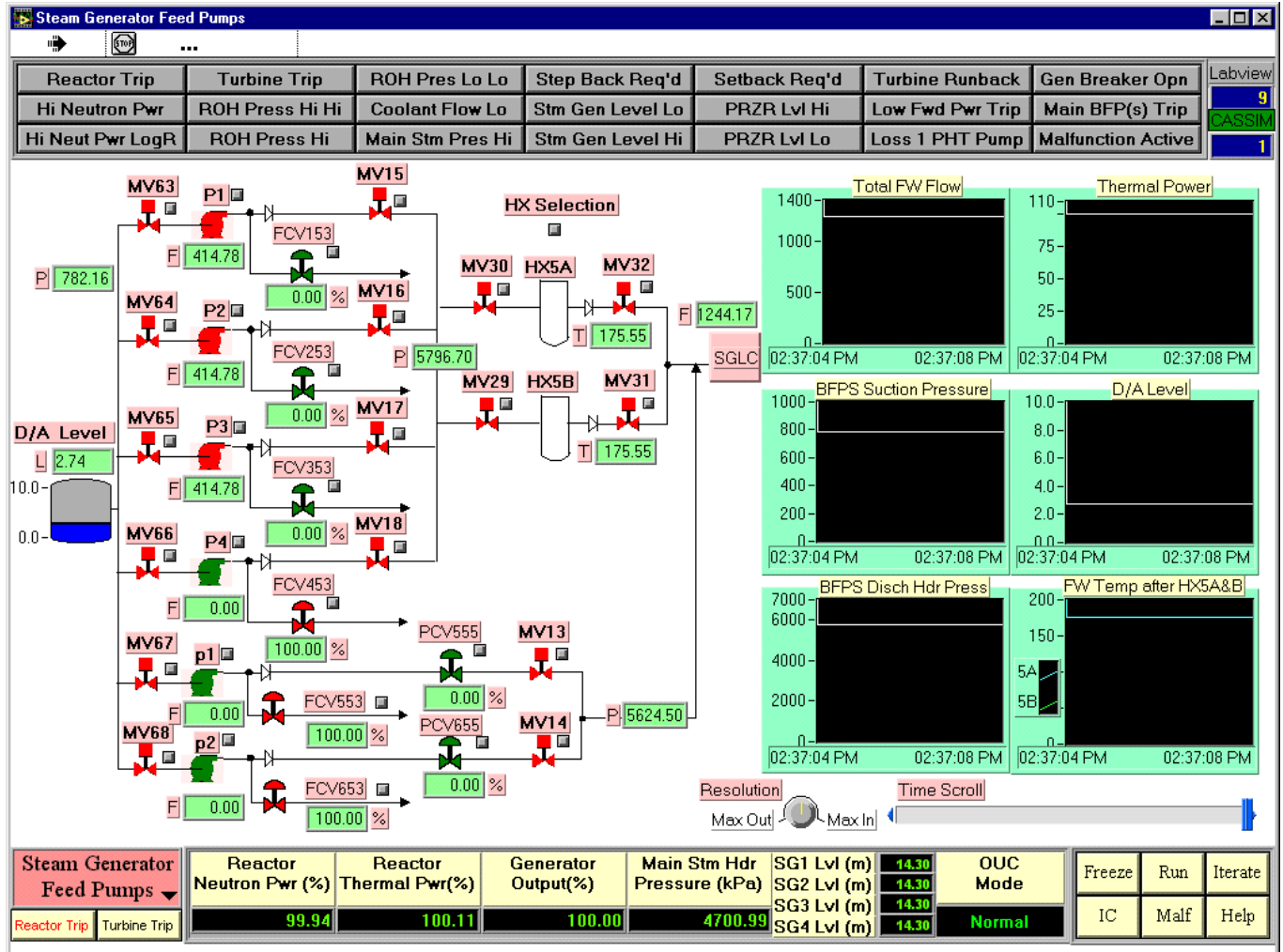

2.10 STEAM GENERATOR LEVEL CONTROL PAGE

Screen shows each of the four boilers and associated level control valves. The following parameters are described (starting near the top of the screen) for Steam Generator 1, the same applies to SG 2, 3 and 4.

- Steam Generator Flow (kg/sec)
- Steam Generator Level (m)
- Reheater Flow (kg/sec)
- Feedwater Flow (kg/sec)
- Large Level Control Valve (LCV103) Status and Opening (%)
- Large Level Control Isolation Motorized Valve (MV53) Status and AUTO/MANUAL Controller Popup Menu
- Large Level Control Valve (LCV101) Status and Opening (%)
- Large Level Control Isolation Motorized Valve (MV45) Status and AUTO/MANUAL Controller Popup Menu
- Small Level Control Valve (LCV102) Status and Opening (%)
- Small Level Control Isolation Motorized Valve (MV49) Status and AUTO/MANUAL Controller Popup Menu
- Steam Generator 1 Level Control (SG1 SGLC) Popup Menu
- Steam Generator Level Control Setpoint (SGLC SP) Select Popup Menu

Total Steam Flow (kg/sec) and Total feedwater Flow (kg/sec) to all four Boilers is shown at the bottom left hand corner.

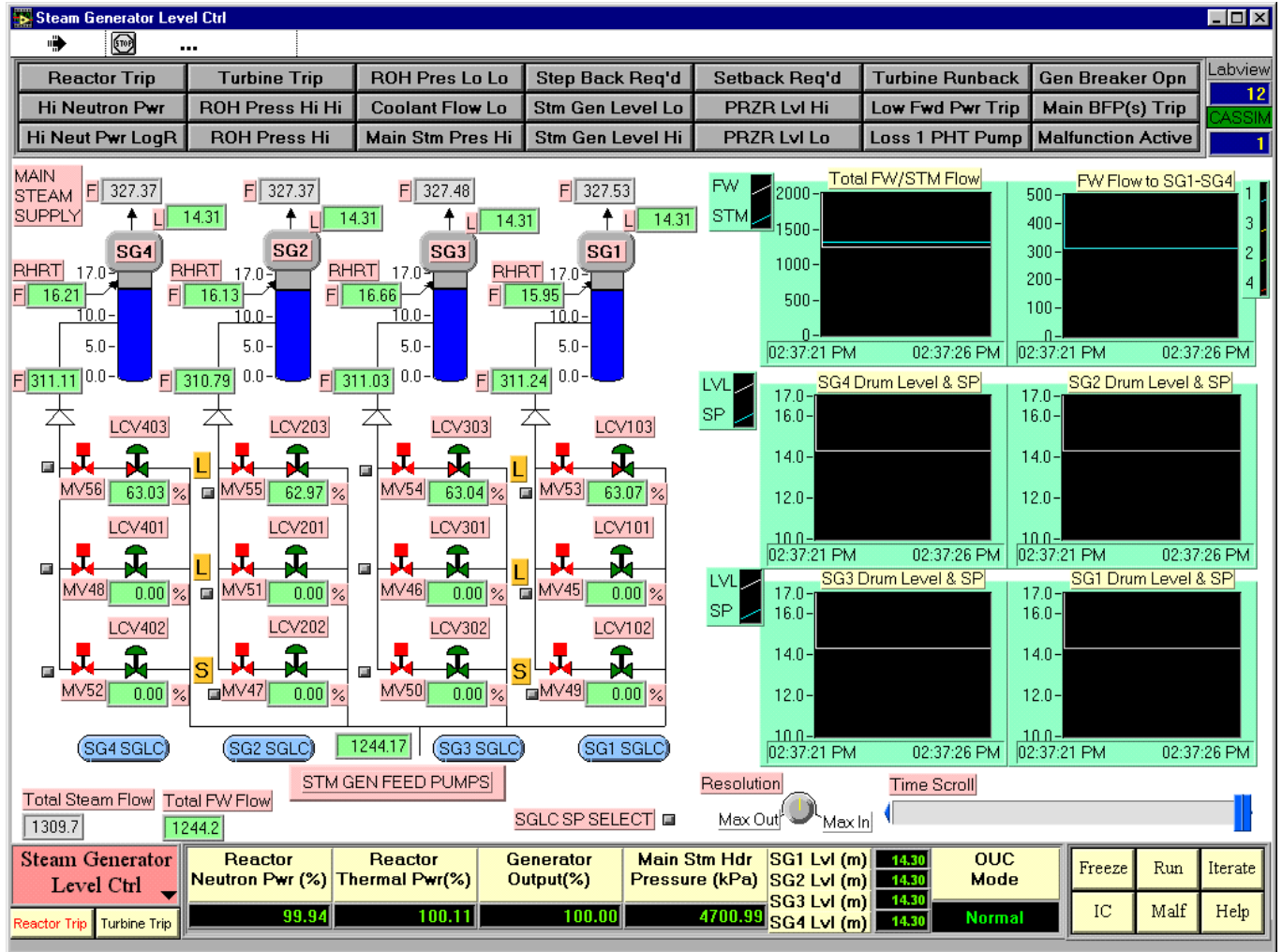

2.11 STEAM GENERATOR LEVEL TRENDS PAGE

Screen shows the steam generator level displays, including the actual level, the alarm, control and trip points. These points are identified as follows:

- TT - Turbine Trip
- HA - High steam generator level Alarm
- CP - Control (or set) Point
- VT - Valve Transfer Point
- LA - Low Steam generator level Alarm
- SB - SetBack reactor
- SDS1 - ShutDown System 1 trip
- SDS2 - ShutDown System 2 trip

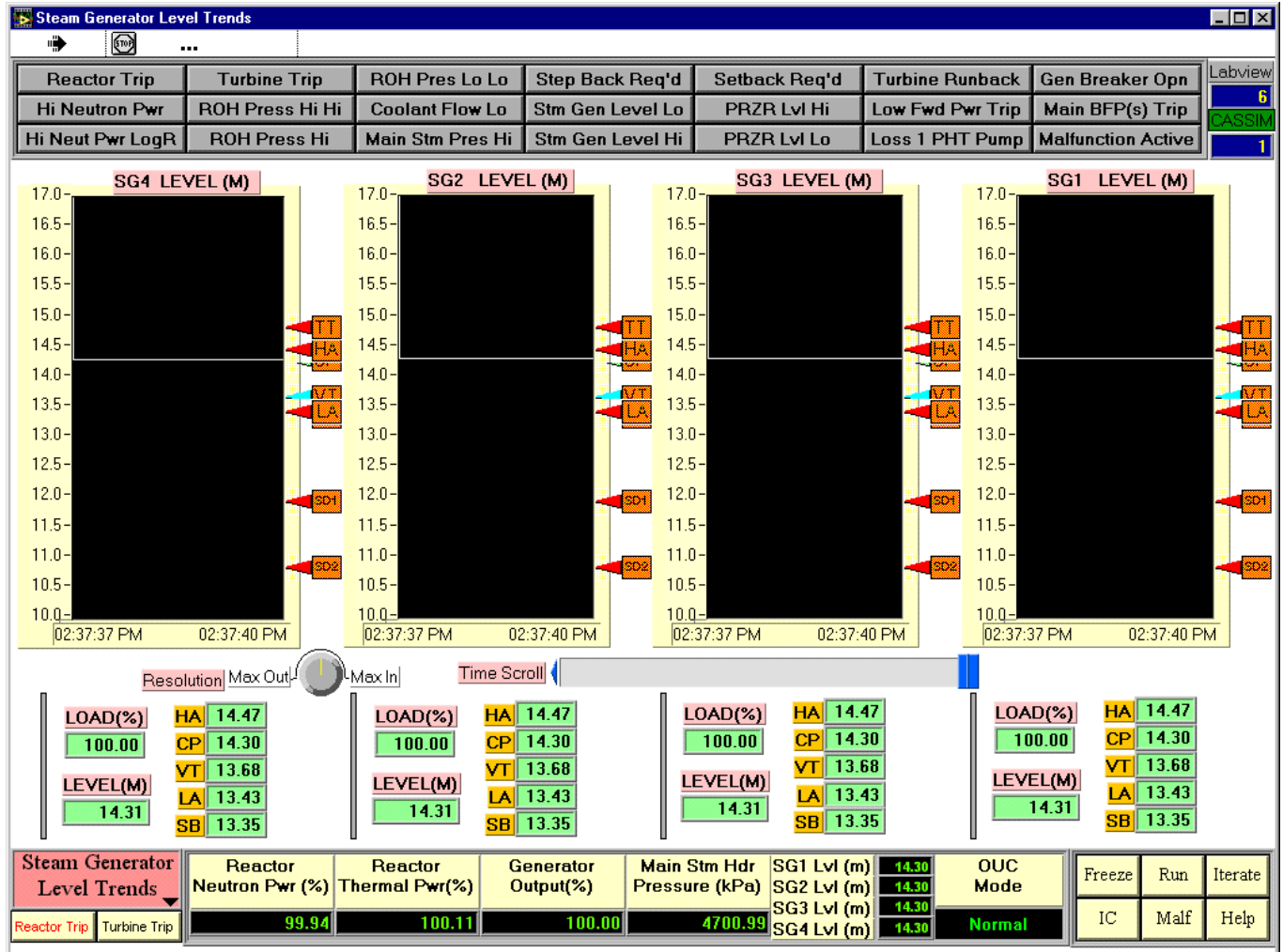

2.12 STEAM GENERATOR LEVEL MANUAL CONTROL

- This screen allows the manual control of the level in each of the four steam generators. Since the actions are the same for any one steam generator, SG1 is the only one described here.
- Under normal operating conditions all level control valves are under DCC Control. At full power normally one large valve (LCV103 for SG1 at the 100%FP Initial Condition) is in control, the other large valve and the small valve are closed.
- While under DCC control the MAN O/P (Manual Output) station tracks the DCC signal.
- Transferring control from DCC to MANUAL allows direct control of the valve's position by the operator.
- For the small valves, transfer from DCC to AUTO allows for tuning of the controller, and valve control to be transferred from the DCC to either AUTO or MANUAL control.

Steam Generator Level Manual Ctrl							Labview
Reactor Trip	Turbine Trip	ROH Pres Lo Lo	Step Back Req'd	Setback Req'd	Turbine Runback	Gen Breaker Opn	6
Hi Neutron Pwr	ROH Press Hi Hi	Coolant Flow Lo	Stm Gen Level Lo	PRZR Lvl Hi	Low Fwd Pwr Trip	Main BFP(s) Trip	CASSIM
Hi Neut Pwr LogR	ROH Press Hi	Main Stm Pres Hi	Stm Gen Level Hi	PRZR Lvl Lo	Loss 1 PHT Pump	Malfunction Active	1

SG1	L LCV 103 VALVE(%)	DCC	POS	63.07	MAN O/P	<input type="checkbox"/>
	L LCV 101 VALVE(%)	DCC	POS	0.00	MAN O/P	<input type="checkbox"/>
	S LCV 102 VALVE(%)	DCC	POS	0.00	CONTROLLER	<input type="checkbox"/>
SG3	L LCV 303 VALVE(%)	DCC	POS	63.04	MAN O/P	<input type="checkbox"/>
	L LCV 301 VALVE(%)	DCC	POS	0.00	MAN O/P	<input type="checkbox"/>
	S LCV 302 VALVE(%)	DCC	POS	0.00	CONTROLLER	<input type="checkbox"/>
SG2	L LCV 203 VALVE(%)	DCC	POS	62.97	MAN O/P	<input type="checkbox"/>
	L LCV 201 VALVE(%)	DCC	POS	0.00	MAN O/P	<input type="checkbox"/>
	S LCV 202 VALVE(%)	DCC	POS	0.00	CONTROLLER	<input type="checkbox"/>
SG4	L LCV 403 VALVE(%)	DCC	POS	63.03	MAN O/P	<input type="checkbox"/>
	L LCV 401 VALVE(%)	DCC	POS	0.00	MAN O/P	<input type="checkbox"/>
	S LCV 402 VALVE(%)	DCC	POS	0.00	CONTROLLER	<input type="checkbox"/>

Steam Generator Lvl Man Ctrl		Reactor Neutron Pwr (%)	Reactor Thermal Pwr(%)	Generator Output(%)	Main Stm Hdr Pressure (kPa)	SG1 Lvl (m)	SG2 Lvl (m)	SG3 Lvl (m)	SG4 Lvl (m)	OUC Mode	Freeze	Run	Iterate
Reactor Trip	Turbine Trip	99.94	100.11	100.00	4700.99	14.30	14.30	14.30	14.30	Normal	IC	Malf	Help

2.13 EXTRACTION STEAM PAGE

Screen shows the extraction steam flows from the Main Steam system to the Deaerator and the High Pressure Heaters in addition to the steam flow to the Turbine. The following parameters are displayed:

- Main Steam Header Pressure (MPa)
- Steam Flow to the Turbine (kg/sec)
- Steam flow to the Deaerator from the Main Steam Header (kg/sec)
- Extraction Steam flow to the Deaerator (kg/sec)
- Extraction Steam flow to the High Pressure Heaters (kg/sec)
- Deaerator Level (m)
- Deaerator Pressure (kPa)
- Valve Status for MSV (Motorized or Emergency Stop Valve) and HPCV (High Pressure Turbine Control or Governor Valve)
- Valve status and popup menus to provide for manual control of motorized valves MV1, 2 and 3
- Valve status and popup menu for AUTO/MANUAL selection and controller parameter tuning

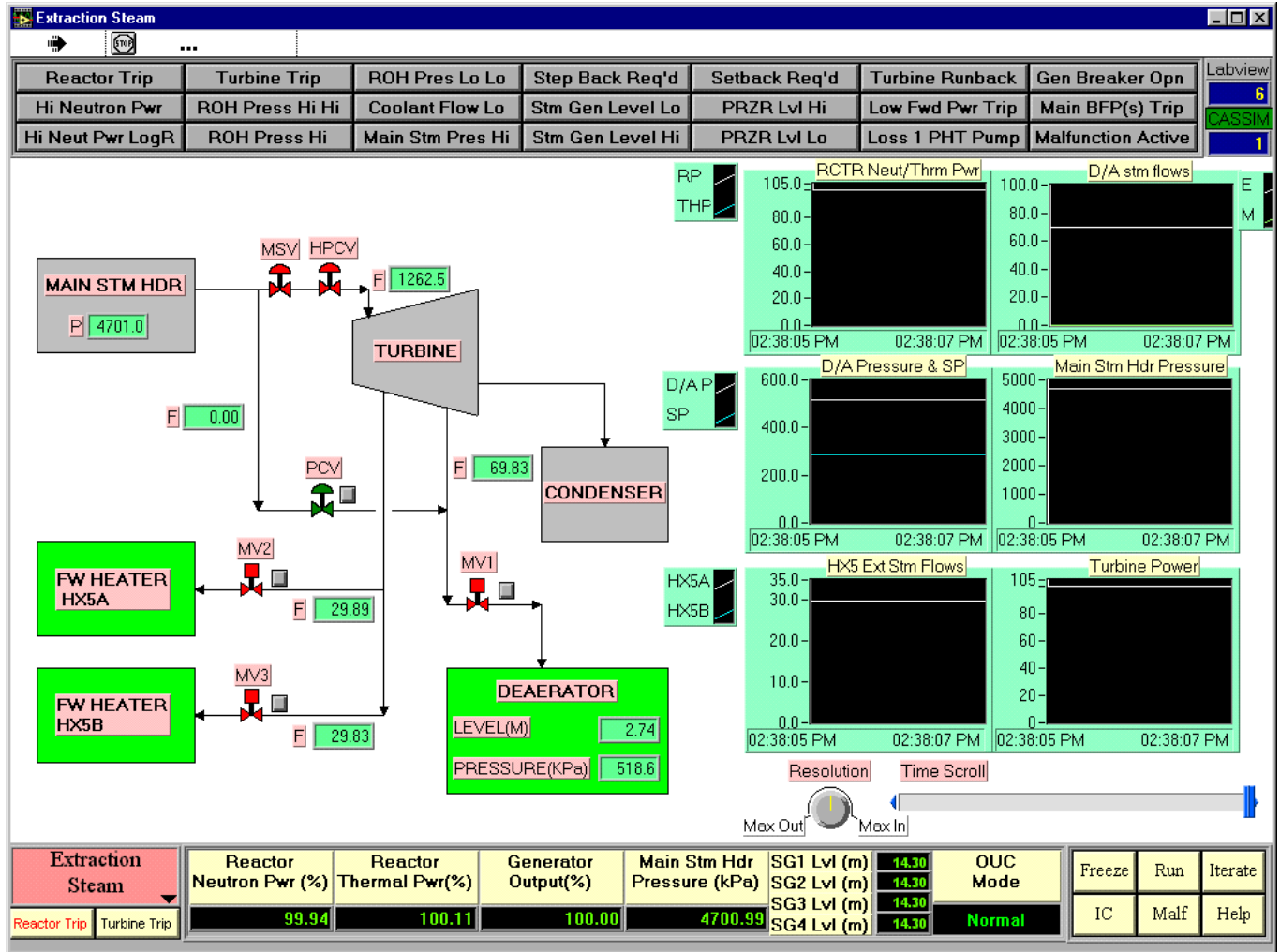

2.14 TURBINE GENERATOR PAGE

Shows the main parameters and controls associated with the Turbine and the generator. The parameters displayed are:

- Boiler 1, 2, 3, 4 Level (m)
- status of Main Steam Safety Valves (MSSV)
- status, opening and flow through the Atmospheric Steam Discharge Valves (ASDV) and the Condenser Steam Discharge Valves (CSDV)
- Steam Flow to the Turbine (kg/sec)
- Governor Control Valve Position (% open)
- Generator Output (MW)
- Turbine/Generator Speed of Rotation (rpm)
- Generator Breaker Trip Status
- Turbine Trip Status
- Turbine Control Status
- All the trend displays have been covered elsewhere or are self explanatory

The following pop-up menus are provided:

- TURBINE RUNBACK - sets Target (%) and Rate (%/sec) of runback when 'Accept' is selected
- TURBINE TRIP STATUS - Trip or Reset
- ASDV and CSDV AUTO/MANUAL Control - AUTO Select, following which the Manual Position of the valve may be set

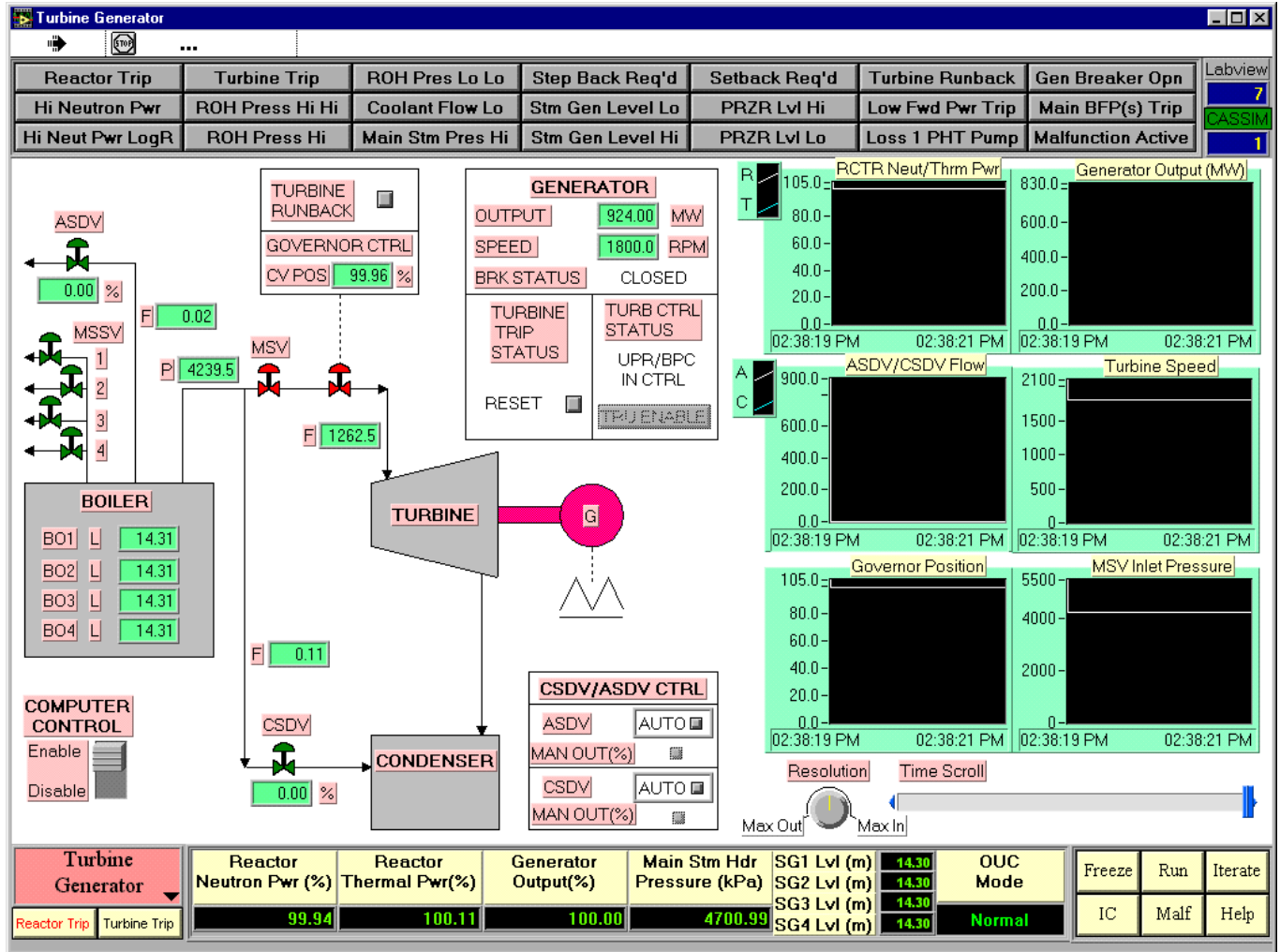

2.15 RRS / DPR PAGE

This screen permits control of reactor power setpoint and its rate of change while under Reactor Regulating System (RRS) control, i.e. in 'alternate' mode. Several of the parameters key to RRS operation are displayed on this page.

- The status of reactor control is indicated by the four blocks marked MODE, SETBACK, STEPBACK AND TRIP. They are normally green but will turn yellow when in the abnormal state.
 - ⇒ MODE will indicate whether the reactor is under NORMAL to ALTERNATE control, this status can also be changed here.
 - ⇒ SETBACK status is indicated by YES or NO; Setback is initiated automatically under the prescribed conditions by RRS, but at times the operator needs to initiate a manual Setback, which is done from this page on the Simulator: the Target value (%) and Rate (%/sec) need to be input.
 - ⇒ STEPBACK status is indicated by YES or NO; Stepback is initiated automatically under the prescribed conditions by RRS, but at times the operator needs to initiate a manual Stepback, which is done from this page on the Simulator: the Target value (%) need to be input.
 - ⇒ TRIP status is indicated by YES or NO; trip is initiated by the Shutdown Systems, if the condition clears, it can be reset from here. Note however, that the tripped SDS#1 must also be reset before RRS will pull out the shutdown rods, this must be done on the Shutdown Rods Page
- Key components of RRS and DPR control algorithm are also shown on this screen.
 - ⇒ The ACTUAL SETPOINT is set equal to the NORMAL SETPOINT under UPR control ('normal mode'), the upper and lower limits on this setpoint can be specified here.
 - ⇒ The ACTUAL SETPOINT is set equal to the ALTERNATE SETPOINT under RRS control ('alternate mode'); the value of ALTERNATE SETPOINT is input on this page.
 - ⇒ Operation of HOLD POWER while in 'normal mode' selects 'alternate mode' and sets DEMANDED POWER SETPOINT equal to the measured Neutron Power. However, in 'alternate mode' it does not respond as it should.
 - ⇒ The computed values of DEMANDED POWER SETPOINT, DEMANDED RATE SETPOINT and POWER ERROR are shown on this page, both on the block diagram and on the trend plots.
 - ⇒ The Absorbers, the Liquid Zones and the Adjusters can be placed on Manual, but no manual operation of these devices is possible on this page.
 - ⇒ Neutron Power, and Thermal are displayed as part of the block diagram, these readings are the same as at the bottom of each page. However, PWR LOG RATE can only be observed on this page.

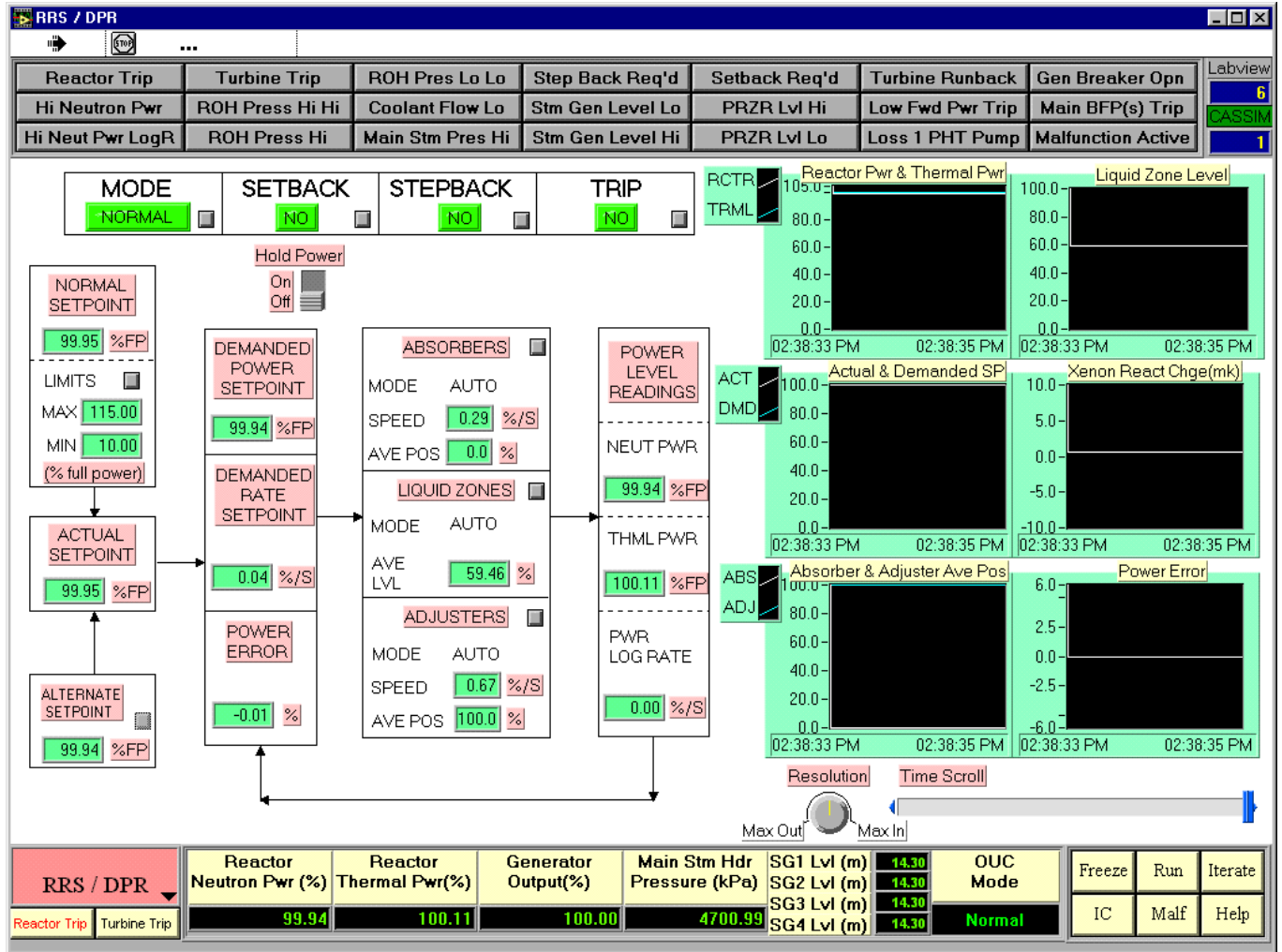

2.16 UPR PAGE

This screen permits control of station load setpoint and its rate of change while under Unit Power Regulator (UPR) control, i.e. 'normal' mode. Control of the Main Steam Header Pressure is also through this screen, but this is not usually changed under normal operating conditions.

- OUC (overall Unit Control) MODE can be changed from NORMAL to ALTERNATE.
- TARGET LOAD - on selection Station Load (%) and Rate of Change (%/sec) can be specified; change becomes effective when 'Accept' is selected.
 - ⇒ The OPERATOR INP TARGET is the desired setpoint inserted by the operator; the CURRENT TARGET will be changed at a POWER RATE specified by the operator.
 - ⇒ Note that the RANGE is only an advisory comment, numbers outside the indicated range of values may be input on the Simulator.
- MAIN STEAM HEADER PRESSURE SETPOINT (MPa) - alters the setpoint, which is rarely done during power operation. Caution must be exercised when using this feature on the Simulator, since the requested change takes place in a step fashion as soon as the change is made; changes should be made in increments of 0.1 MPa.

UPR

Reactor Trip	Turbine Trip	ROH Pres Lo Lo	Step Back Req'd	Setback Req'd	Turbine Runback	Gen Breaker Opn	Labview
Hi Neutron Pwr	ROH Press Hi Hi	Coolant Flow Lo	Stm Gen Level Lo	PRZR Lvl Hi	Low Fwd Pwr Trip	Main BFP(s) Trip	8
Hi Neut Pwr LogR	ROH Press Hi	Main Stm Pres Hi	Stm Gen Level Hi	PRZR Lvl Lo	Loss 1 PHT Pump	Malfunction Active	CASSIM
							1

UNIT POWER RATE & TARGET LOAD

CONTROLLED VARIABLE	CURRENT TARGET	OPERATOR INP TARGET	RANGE
TARGET LOAD(%) <input type="checkbox"/>	100.00	100.00	5 TO 100
POWER RATE (%/S)	0.80	0.80	0.01 TO 1

MAIN STEAM HEADER PRESSURE SETPOINT

CONTROLLED VARIABLE	CURRENT TARGET	OPERATOR INP TARGET	RANGE
MAIN STM HDR PRES SETPOINT(MPa) <input type="checkbox"/>	4.701	4.701	4 TO 5

Resolution Time Scroll

Max Out | | Max In

UPR System		Reactor Neutron Pwr (%)	Reactor Thermal Pwr(%)	Generator Output(%)	Main Stm Hdr Pressure (kPa)	SG1 Lvl (m) 14.30	SG2 Lvl (m) 14.30	SG3 Lvl (m) 14.30	SG4 Lvl (m) 14.30	OUC Mode	Freeze	Run	Iterate
Reactor Trip	Turbine Trip	99.94	100.11	100.00	4700.99	Normal	Normal	Normal	Normal	Normal	IC	Malf	Help

2.17 TREND

This screen shows the trend plots for eight simulated plant parameters. The list below gives the parameter names that may be selected for plotting on any one of the eight trend displays. The list can be displayed by pointing to the black triangle at the top right hand corner of the selected plot, holding down the left mouse button and highlighting the desired parameter.

Note that the vertical axis on each plot has its scale adjusted automatically to correspond to the maximum and minimum values of the parameter during the time segment indicated by the horizontal axis.

This trend feature should be used whenever parameters from different systems need to be viewed on the one display, and none of the other pages has the required combination of parameters.

Reactor Power (Normalized)	PHT Liquid Relief Flow (kg/s)
Total Delta mK (mK)	Bleed Condenser Spray Flow (kg/s)
Xenon Load (mK)	Bleed Condenser Pressure (kPa)
Thermal Power Release In Nuclear Fuel (Normalized)	Bleed Condenser Level (m)
RIH#1 Coolant Temp (Deg C)	Bleed Cooler Outlet Temp (Deg C)
RIH#2 Coolant Temp (Deg C)	Bleed Condenser Outlet Flow (kg/s)
RIH#3 Coolant Temp (Deg C)	Deaerator Pressure (kPa)
RIH#4 Coolant Temp (Deg C)	Deaerator Level (m)
ROH#1 Coolant Temp (Deg C]	Main Stm to Deaerator PCV Pos (Norm)
ROH#2 Coolant Temp (Deg C)	Ave Temp of Feedwater at HPHX Outlet (Deg C)
ROH#1 Pressure (kPa)	Feed water Flow to Boiler#1 (kg/s)
ROH#2 Pressure (kPa)	Feed water Flow to Boiler# 2(kg/s)
RIH#1 Pressure (kPa)	Feed water Flow to Boiler#3 (kg/s)
RIH#2 Pressure (kPa)	Feed water Flow to Boiler#4 (kg/s)
RIH#3 Pressure (kPa)	Boiler#1 Drum Level (m)
RIH#4 Pressure (kPa)	Boiler#2 Drum Level (m)
Measured Reactor Thermal Power (Normalized)	Boiler#3 Drum Level (m)
Coolant Flow Rate to Quadrant 1 (kg/s)	Boiler#4 Drum Level (m)
Coolant Flow Rate to Quadrant 2 (kg/s)	Boiler#1 Drum Level Set Point (m)
Coolant Flow Rate to Quadrant 3 (kg/s)	Boiler#2 Drum Level Set Point (m)
Coolant Flow Rate to Quadrant 4 (kg/s)	Boiler#3 Drum Level Set Point (m)
Exit Quality in Channel #1 (Normalized)	Boiler#4 Drum Level Set Point (m)
Exit Quality in Channel #2 (Normalized)	Main Steam Header Temp(Deg C)
Exit Quality in Channel #3 (Normalized)	Main Steam Header Pressure (kPa)
Exit Quality in Channel #4 (Normalized)	Pressure at MSV inlet (kPa)
Pressurizer Pressure (kPa)	Steam Flow through ASDV (kg/s)
Pressurizer Temperature (Deg C)	Steam Flow through CSDV (kg/s)
Pressurizer Level (m)	Total Steam Flow through Relief Valves (kg/s)
Pressurizer Level Set Point (m)	Total Steam Flow from Boiler (kg/s)
PHT Liquid Bleed Flow (kg/s)	Steam Flow to Turbine (kg/s)
PHT Total Liquid Feed Flow (kg/s)	Turbine Mechanical Power (Normalized)
PHT Reflux feed flow (kg/s)	Turbine Gross Electrical Power (Normalized)
	Turbine Speed (RPM)



CANDU-9 COMPACT SIMULATOR

EXERCISES

Lecture Notes

prepared by:

Dr. George Bereznai

Dean, Energy Management and
Nuclear Science, at the University of
Ontario Institute of Technology,
Canada

george.bereznai@uoit.ca

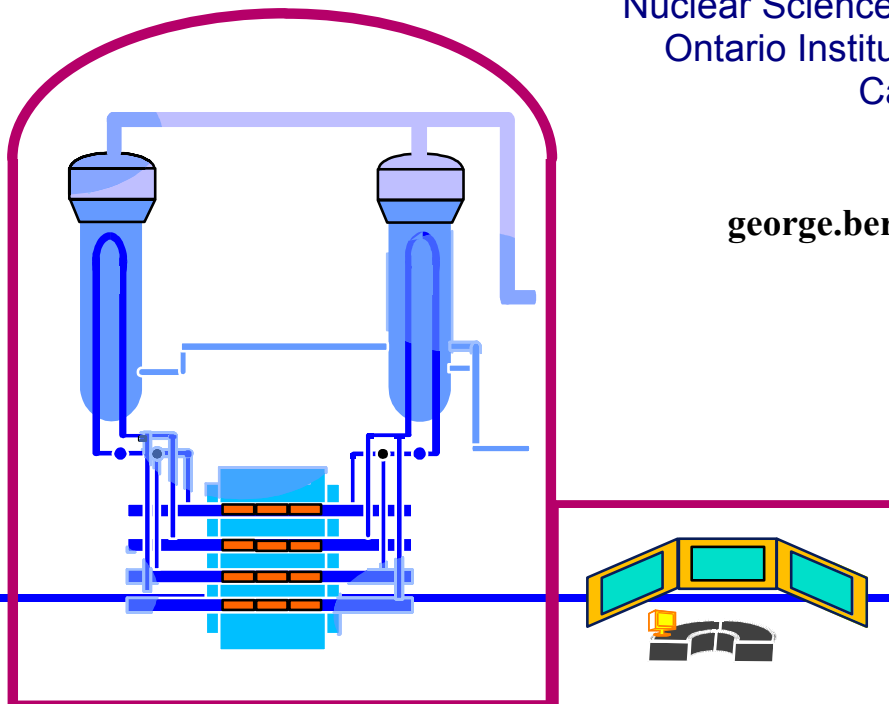

CONTENTS

1. OVERALL UNIT CONTROL
 - 1.1 POWER MANEUVER
 - 1.2 RESPONSE TO POWER MANEUVER (NORMAL MODE)
 - 1.3 TEMPERATURE PROFILE ACROSS A CANDU 9 UNIT
2. REACTOR REGULATING SYSTEM OPERATION
 - 2.1 POWER MANEUVER IN 'ALTERNATE' MODE
 - 2.2 RESPONSE OF RRS CONTROL ALGORITHM
 - 2.3 REACTOR AND RRS RESPONSE TO POWER MANEUVER
 - 2.4 POWER MANEUVER UNDER MANUAL CONTROL
 - 2.5 MANUAL WITHDRAWAL OF ADJUSTER RODS
3. REACTOR REGULATING SYSTEM MALFUNCTIONS AND TRIPS
 - 3.1 FAIL OPEN LIQUID ZONE INLET VALVES
 - 3.2 FAIL CLOSED LIQUID ZONE INLET VALVES
 - 3.3 ONE BANK OF ABSORBER RODS DROP
 - 3.4 SDS#1 REACTOR TRIP AND RECOVERY
 - 3.5 SDS#1 REACTOR TRIP AND POISON-OUT
 - 3.6 SDS#1 REACTOR TRIP AND POISON OVERRIDE
4. HEAT TRANSPORT SYSTEM EXERCISES
 - 4.1 PHT LRV (CV20) FAILS OPEN
 - 4.2 PHT STEAM BLEED VALVE (CV22) FAILS OPEN
 - 4.3 PHT FEED VALVE (CV12) FAILS OPEN
 - 4.4 PRZR SURGE VALVE (MV1) FAILS CLOSED
 - 4.5 PHT BLEED VALVE (CV5) FAILS OPEN
5. STEAM AND FEEDWATER SYSTEM EXERCISES
 - 5.1 FW LCV101 FAILS OPEN
 - 5.2 FW LCV101 FAILS CLOSED
 - 5.3 STEAM GENERATOR #1 FW FT IRRATIONAL
 - 5.4 STEAM GENERATOR PRESSURE CONTROL EXERCISE
 - 5.5 REACTOR TRIP AND UNIT RECOVERY
6. OVERALL UNIT EXERCISES
 - 6.1 FAIL CLOSED ALL F/W LEVEL CONTROL MOTORIZED VALVES
 - 6.2 ALL MAIN BFPs TRIP
 - 6.3 TURBINE SPURIOUS TRIP
 - 6.4 THROTTLE PT (PRESSURE TRANSMITTER) FAILS LOW
 - 6.5 RIH#1 SMALL BREAK
 - 6.6 MAIN STEAM HEADER BREAK

1. OVERALL UNIT CONTROL

1.1 POWER MANEUVER: 10% Power Reduction and Return to Full Power

- (1) Initialize Simulator to 100% full power;
- (2) verify that all parameters are consistent with full power operation;
- (3) select the UPR page, and change the scale on the "Reactor Pwr & Thermal Pwr" and "Current Target Load & Turbine Pwr" graphs to be between 80 and 110 percent, the "Main Steam Hdr Pressure & SP" to 4500 and 5000 kPa, "Boiler Level" to 13 and 15 meters, and set "Resolution" to "Max Out";
- (4) reduce unit power in the 'normal' mode, i.e.
 - using the UPR display
 - select 'TARGET LOAD (%)' pop-up menu
 - in pop-up menu lower 'target' to 90.00% at a 'Rate' of 1.0 %/sec
 - 'Accept' and 'Return'
- (5) observe the response of the displayed parameters until the transients in Reactor Power and Steam Pressure are completed (approximately 4 minutes and full time scale on the graph) without freezing the Simulator and/or stopping Labview, and explain the main changes;
- (6) continuing the above operation, raise "UNIT POWER" to 100% at a rate of 1.0%FP/sec.

ASSIGNMENT:

- (a) What is the maximum value of Steam Generator Pressure during the above set of maneuvers and at what stage of the transients does it occur?
- (b) What is the minimum value of Steam Generator Pressure during the above set of maneuvers and at what stage of the transients does it occur?
- (c) Is the turbine leading the reactor or the reactor leading the turbine in the above transients? Please explain on what parameter observations do you base your answer.

1.2 RESPONSE TO POWER MANEUVER (NORMAL MODE)

- Initialize the Simulator to 100%FP, reduce power using UPR in 25% steps at 0.5%/sec (trip the reactor for the 0% state) and record the following values:

Parameter	Unit	100%	75%	50%	25%	0%	Comments
Reactor Power	%						
ROH Pressure	MPa						
ROH Temperature	°C						
RIH Pressure	MPa						
RIH Temperature	°C						
Pressurizer Level	m						
HT Pump Flow	Mg/s						
Boiler Pressure	MPa						
Boiler Temperature	°C						
Boiler Level	m						
Steam Flow	kg/s						
Feedwater Flow	kg/s						
Turbine-Generator Power	%						

ASSIGNMENT:

Under “Comments” please note the type of parameter change as a function of reactor power 0% → 100%FP: constant, linear increase or decrease, non-linear increase or decrease.

1.3 TEMPERATURE PROFILE ACROSS A CANDU 9 UNIT AT FULL POWER

- (1) Initialize the Simulator to 100% Full Power;
- (2) record the missing values of the parameters in the table below.

Station Equipment	Pressure (kPa)	Temperature (°C)
Reactor Inlet Header		
Reactor Outlet Header		
Steam Generator		
HP Turbine Exhaust	900	170
LP Turbine Inlet	900	230
Condenser	5	35
LP Heater Outlet	700	100
Deaerator		130
Boiler Feedpump Inlet		
HP Heater Outlet		
Preheater Outlet		

ASSIGNMENT:

Plot these parameters on the attached grid.

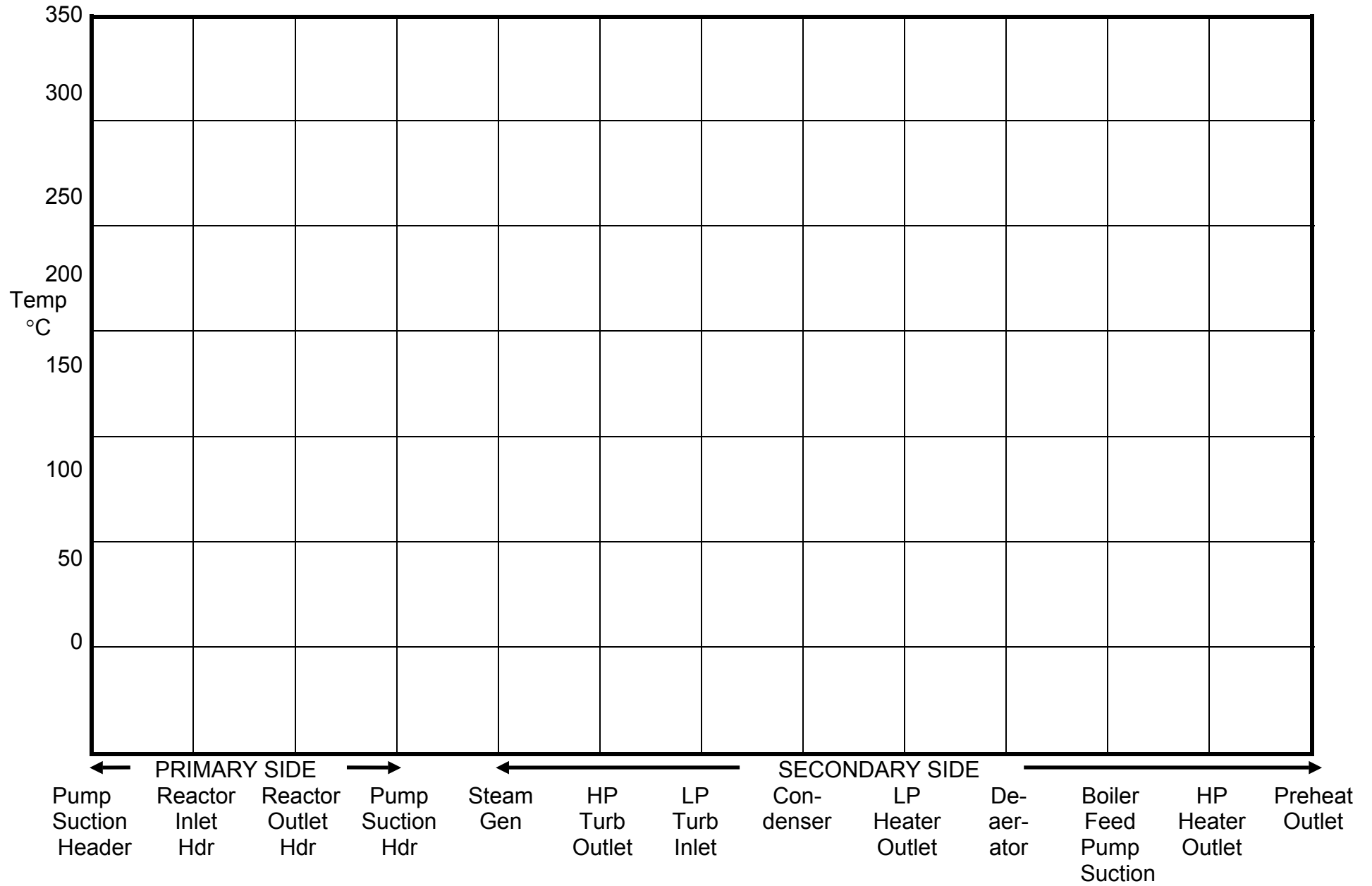

2. REACTOR REGULATING SYSTEM OPERATION

2.1 POWER MANEUVER IN 'ALTERNATE' MODE

- (1) Initialize the Simulator to 100%FP, select 'ALTERNATE MODE", and record parameter values in column (1);
- (2) reduce power using RRS to 50% at 0.5%/sec, observe parameter changes during transient, freeze the Simulator as soon as Reactor Neutron Power reaches 50% and record parameter values column (2);
- (3) unfreeze and let parameters stabilize, record parameter values column (3);
- (4) return reactor power to 100%FP at 0.5%/sec, freeze as soon as Reactor Neutron Power reaches 100% and record parameter values column (4);
- (5) unfreeze and let parameters stabilize, record parameter values column (5).

Parameter	Unit	(1) 100%	(2) 50%	(3) 50%	(4) 100%	(5) 100%	Comments
Reactor Neutron Power	%						
Reactor Thermal Power	%						
Average Zone Level	%						
Actual Setpoint	%						
Demanded Power Setpoint	%						
Demanded Rate Setpoint	%/sec						
Power Error	%						
Boiler Pressure	MPa						
Boiler Temperature	°C						
Boiler Level	m						
Steam Flow	kg/s						
Feedwater Flow	kg/s						
Governor valve opening	%						
Turbine-Generator Power	%						

ASSIGNMENT:

(a) Explain the changes in Average Zone Level between each operating state (column):

- (1) → (2)

- (2) → (3)

- (3) → (4)

- (4) → (5)

(b) In Column (2) Reactor Neutron Power is much lower than Turbine-Generator Power. Where is the extra energy coming from?

2.2 RESPONSE OF RRS CONTROL ALGORITHM TO POWER MANEUVER

- (1) Initialize the Simulator to 100%FP and from the Reactivity Control page note the position of the operating point on the attached diagram (confirm the value of Average Zone Level on the Plant Overview page);
- (2) insert a power reduction request using RRS to 70%FP at 0.8%/sec and freeze the simulator (remember that "ALTERNATE MODE" must be selected if power level change is to be requested via RRS);
- (3) go to the Reactivity Control page, unfreeze, and note the path of the operating point on the attached diagram, until power error has stabilized at or near zero (about 3 - 4 minutes);
- (4) confirm the value of average zone level on the Plant Overview page.

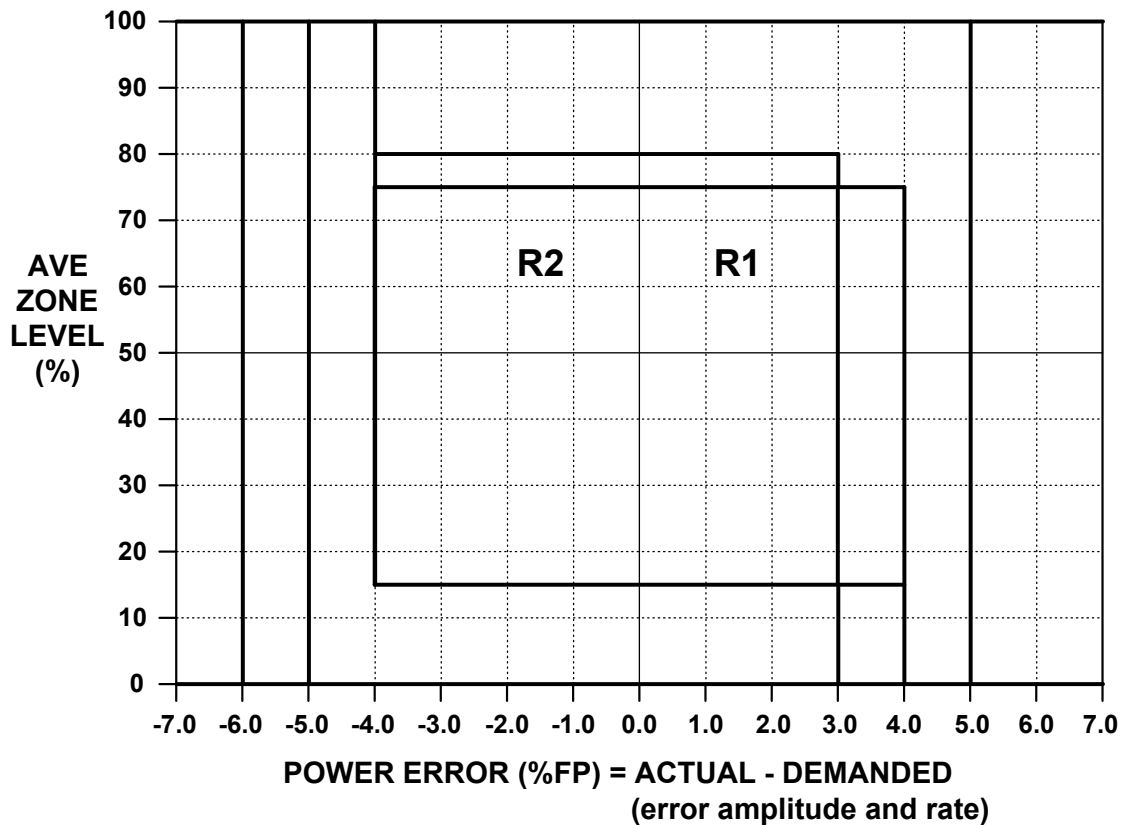

ASSIGNMENT:

- (a) Why does the operating point start out in Region R1, then go to Region R2?
- (b) What is the final value of the average zone level?
Why is the final zone level higher than the original zone level?

2.3 REACTOR AND RRS RESPONSE TO POWER MANEUVER

- (1) Initialize the Simulator to 100%FP and from the Reactivity Control page note the position of the operating point on the attached diagram;
- (2) insert a power reduction request using RRS to 10%FP at 0.8%/sec and freeze the simulator;
- (3) go to the Reactivity Control page, unfreeze, and note the path of the operating point on the attached diagram, until at least one Adjuster Rod bank is out of the reactor (about 20 minutes) - once the first Adjuster Bank is more than 50% withdrawn, place Absorbers on Manual and drive them fully OUT.

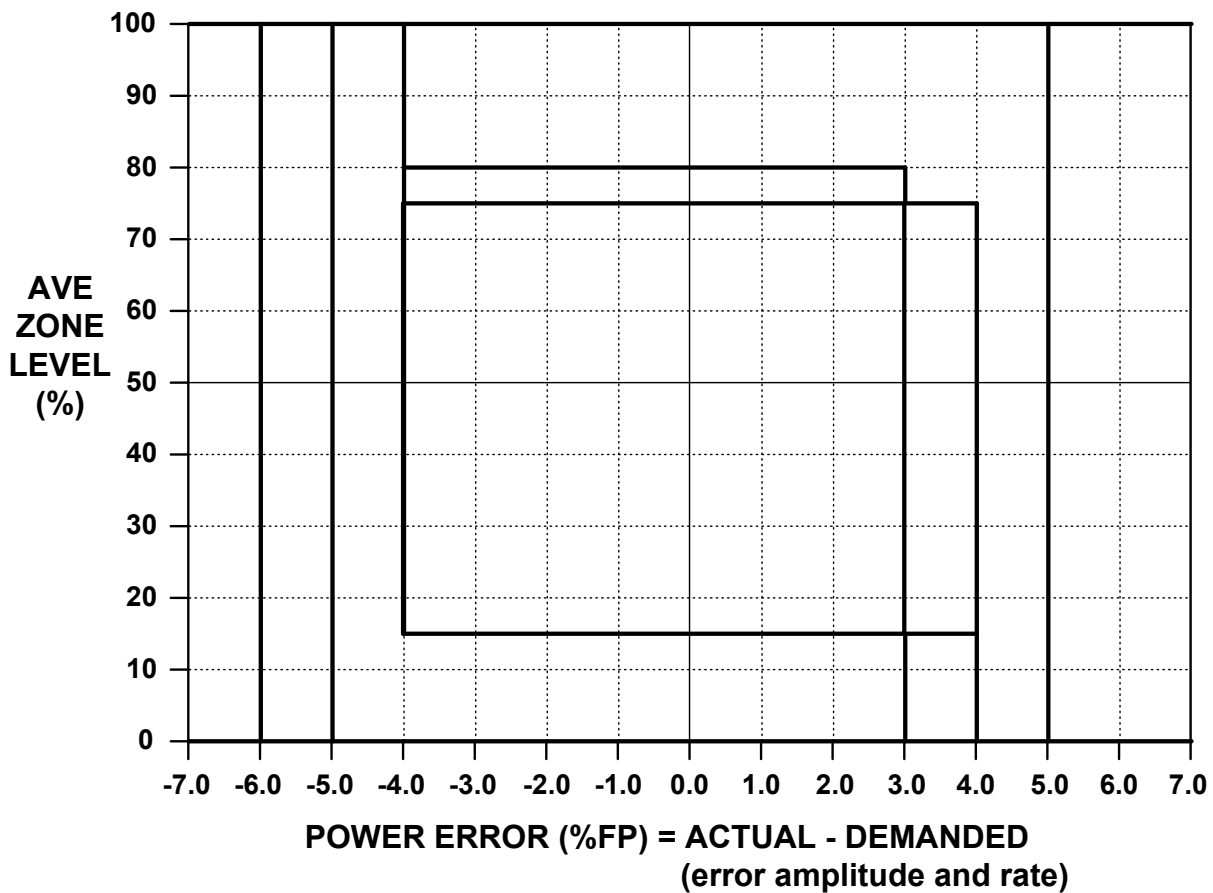

ASSIGNMENT:

- (a) Compare the response to case 2.2 and explain the main differences, particularly the 'end' state.
- (b) Explain what would happen to the reactor if the setpoint remained at 10%FP for several hours.

2.4 POWER MANEUVER UNDER MANUAL CONTROL

- (1) Initialize the Simulator to 100%FP and select ALTERNATE MODE. On the Reactivity Control page place the controllers for LIQUID ZONE, ABSORBERS and ADJUSTERS on MANUAL. Do not use liquid zone control during this exercise;
- (2) using Absorber and Adjuster drives on Manual, maneuver reactor power so as to reduce generator power to a level between $80 \pm 1\%$ FP and Main Stm Header Pressur between 4700 ± 50 kPa (if the CSDVs open, place them on MANUAL and keep them closed).

ASSIGNMENT:

- (a) Note the time taken from the start of lowering reactor power until steady operation within the specified error limits is achieved as compared with a power reduction rate of 0.5%FP/sec;
- (b) note any difficulties in controlling the unit.

2.5 MANUAL WITHDRAWAL OF ADJUSTER RODS

- (1) Initialize the Simulator to 100%FP and select ALTERNATE MODE. On the Reactivity Control page place the controllers for LIQUID ZONE, ABSORBERS and ADJUSTERS on MANUAL. Do not use liquid zone control during this exercise;
- (2) manually withdraw the Adjuster rods.

ASSIGNMENT:

Describe and explain the response of the Reactor and related systems.

3. REACTOR REGULATING SYSTEM MALFUNCTIONS AND TRIPS

3.1 FAIL OPEN LIQUID ZONE INLET VALVES

- (1) Initialize the Simulator to 100%FP, select ALTERNATE MODE and go to the Reactivity Control page;
- (2) place LIQUID ZONE controller on MANUAL and select Control Valve Position Manual Output to 100%;
- (3) record the following data:

Time (min)	0	0.5	1	2	4	6	8	10
Average Zone Level (%)								
Reactor Neutron Power (%FP)								
Reactor Power Error (%)								
Generator Output (%FP)								

ASSIGNMENT:

- (a) What happens to Reactor Neutron Power and how the Reactor Regulating responds?
- (b) Explain why reactor power oscillates after the initial transient is over?
- (c) What should the operator do to stop the oscillations in reactor power?

3.2 FAIL CLOSED LIQUID ZONE INLET VALVES

- (1) Initialize the Simulator to 100%FP, select ALTERNATE MODE, and go to the Reactivity Control page;
- (2) place LIQUID ZONE controller on MANUAL and select Control Valve Position Manual Output to 0%;
- (3) record the following data:

Time (sec)	0	10	20	30	40	50	60	120
Average Zone Level (%)								
Reactor Neutron Power (%FP)								
Reactor Power Error (%)								
Generator Output (%FP)								

ASSIGNMENT:

- (a) Describe the responses of the Reactor and Reactor Regulating System.
- (b) Explain the differences between Exercise 3-1 and 3-2, noting the difference in reactor physics response.
- (c) Why does the reactor trip?

3.3 ONE BANK OF ABSORBER RODS DROP

- (1) Initialize the Simulator to 100%FP and from the Reactivity Control page note the position of the operating point on the attached diagram;
- (2) insert the Malfunction “One Bank of Absorber Rods Drop” (use a five second time delay) and the note the time;
- (3) observe system response on the Reactivity Control page and note the path of the operating point on the attached diagram;
- (4) note OUC mode and reactor power level;
- (5) clear the malfunction;
- (6) once the Absorbers have fully withdrawn from the reactor, raise reactor power to a level dependent on the number of Absorber banks out of the reactor and note the time when maximum reactor power level is reached;
- (7) for each bank partially or fully out, reactor power is limited by 5% (i.e. one bank - 95%FP, two banks - 90%FP, etc).

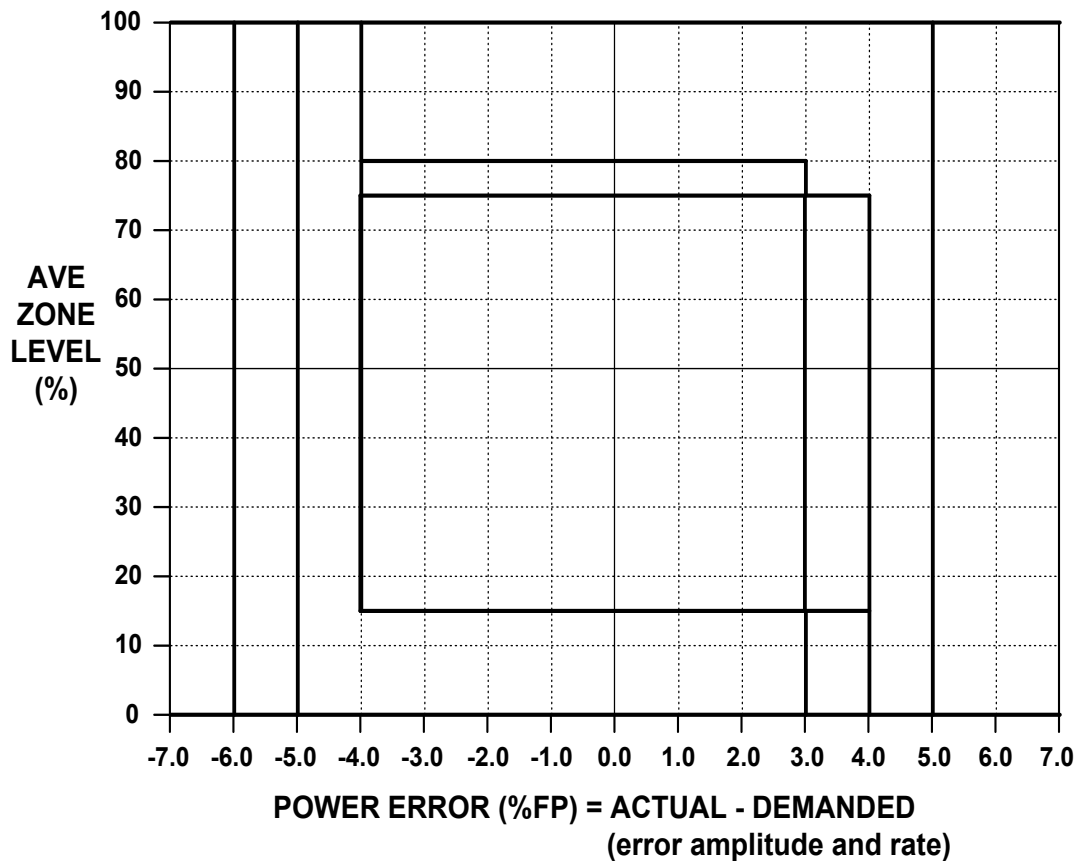

ASSIGNMENT:

- (a) Explain what happened to OUC MODE and Reactor Power after the malfunction was inserted.
- (b) What is the maximum power level that you could achieve? _____
- (c) How many Adjuster Rods were out of the core? _____
- (d) How long after the insertion of the Malfunction was maximum reactor power achieved? _____

3.4 SDS#1 REACTOR TRIP AND RECOVERY

Check the time calibration factor of the Simulator on your computer, and compute the real time response by multiplying all time measurements taken during this exercise by the time calibration factor.

- (1) Initialize the Simulator to 100%FP;
- (2) manually trip the reactor;
- (3) observe the response of the overall unit;
- (4) wait until Generator power is zero and reactor neutron power less than 0.1%;
- (5) reset Reactor Trip and SDS#1;
- (6) record the time (using the display under the chart recorders) needed to withdraw all shutdown rods, and compute the real time from the measured time;
- (7) raise reactor power to 60%FP, using the following rates of power level setpoint increases:

<u>Actual Neutron Power</u>	<u>Rate of Target Increase</u>
$N < 0.5 \text{ \%FP}$	0.01 %FP/sec
$0.5 < N < 5 \text{ \%FP}$	0.1 %FP/sec
$5 < N < 20 \text{ \%FP}$	0.2 %FP/sec
$20 < N < 60 \text{ \%FP}$	0.8 %FP/sec

- (8) observe the response of the reactor regulating system and the reactivity changes that take place.

ASSIGNMENT:

- (a) what is the (real) time taken to withdraw all the adjuster rods from the reactor?
- (b) what is the (real) time needed to raise reactor power to 60%FP after the shutdown rods have been withdrawn?

3.5 SDS#1 REACTOR TRIP AND POISON-OUT

- (1) Initialize the Simulator to 100%FP;
- (2) manually trip the reactor;
- (3) observe the response of the overall unit;
- (4) record the value of Xenon reactivity every ten minutes following the reactor trip;

Time (min)	0	10	20	30	40	50	60
Xenon (mk)							

- (5) wait one hour (real time, i.e. measured time X TCF) before resetting Reactor Trip and SDS#1;
- (6) after the shutdown rods have been withdrawn observe the status of the reactivity control devices;
- (7) attempt to raise reactor power – note response;
- (8) note the reactivity changes that have taken place, in particular note the magnitude and estimate the rate of change of Xenon reactivity build-up.

ASSIGNMENT:

- (a) How many minutes after the reactor trip did the last Adjust Rod bank drive out?
- (b) What was the rate of increase of Xenon reactivity at that time (mk/minute)?
- (c) Why is it not possible to raise reactor power one hour after the reactor trip?

3.6 SDS#1 REACTOR TRIP AND POISON OVERRIDE

Before starting this exercise make sure that you do a time calibration of your simulator and that all times calculated and measured are corrected by the appropriate time calibration factor.

- (1) Using the data from the previous two exercises, estimate the time available to the operator from the initiation of the reactor trip until the trip must be reset to avoid a poison outage: the desired end state of this exercise is reactor power at 60%FP and less than one bank of adjuster rods left in the core (i.e. the last bank is partially withdrawn);
- (2) initialize the Simulator to 100%FP;
- (3) manually trip the reactor;
- (4) wait until the above calculated time has expired;
- (5) reset Reactor Trip and SDS#1;
- (6) raise reactor power to 60%FP;
- (7) note the final state of the adjuster rods and Average Liquid Zone level.

ASSIGNMENT:

Note and explain any differences between Poison Override time you computed and the result you obtained, i.e. record the time that elapses between tripping the reactor and recovering reactor power to 60%FP, as well as the number of Adjuster Rod banks not fully withdrawn from the core.

4. HEAT TRANSPORT SYSTEM EXERCISES

4.1 PHT LRV (CV20) FAILS OPEN

- (1) Initialize the Simulator to the 100% full power state;
- (2) record the initial parameter values;
- (3) insert malfunction "PHT LRV (CV20) FAILS OPEN";
- (4) record the following parameters.

PARAMETER	START	2 min	5 min	10 min	End
Reactor Neutron Power					
Heat Transport (ROH) Pressure					
Pressurizer Pressure					
Pressurizer Level					
Bleed Condenser Pressure					
Bleed Condenser Level					
Feed Flow					
Bleed Flow					
Storage Tank Level					

ASSIGNMENT:

- (a) Why are all Pressurizer Heaters switched ON shortly after the start of the event?
- (b) Why does Pressurizer Level fall?
- (c) After "Bleed CdZR Pressure" reaches about 8.5 MPa, why does it fluctuate?
- (d) What will happen if this condition is allowed to continue for several hours?
- (e) What should the unit operator do to ensure reactor safety?

4.2 PHT STEAM BLEED VALVE (CV22) FAILS OPEN

- (1) Initialize the Simulator to the 100% full power state;
- (2) record the initial parameter values;
- (3) insert malfunction "PHT STEAM BLEED VALVE (CV22) FAILS OPEN";
- (4) record the following parameters.

PARAMETER	START	2 min	5 min	10 min	End
Reactor Neutron Power					
Heat Transport (ROH) Pressure					
Pressurizer Pressure					
Pressurizer Level					
Bleed Condenser Pressure					
Bleed Condenser Level					
Feed Flow					
Bleed Flow					
Storage Tank Level					

ASSIGNMENT:

- (a) Why is Pressurizer Level decreasing after the malfunction is inserted?
- (b) Why is ROH Pressure decreasing?
- (c) Why does the Reactor Trip?
- (d) What corrective action should the unit operator perform to prevent the Reactor Trip?

4.3 PHT FEED VALVE (CV12) FAILS OPEN

- (1) Initialize the Simulator to the 100% full power state;
- (2) record the initial parameter values;
- (3) insert malfunction "PHT FEED VALVE (CV12) FAILS OPEN";
- (4) record the following parameters.

PARAMETER	START	2 min	5 min	10 min	End
Reactor Neutron Power					
Heat Transport (ROH) Pressure					
Pressurizer Pressure					
Pressurizer Level					
Bleed Condenser Pressure					
Bleed Condenser Level					
Feed Flow					
Bleed Flow					
Storage Tank Level					

ASSIGNMENT:

- (a) What are the initial consequences of the increased Feed flow?
- (b) Which control system responds to correct the excess Feed flow? What is the controller action?
- (c) What corrective action could the unit operator take?

4.4 PRZR SURGE VALVE (MV1) FAILS CLOSED

- (1) Initialize the Simulator to the 100% full power state;
- (2) record the initial parameter values;
- (3) insert malfunction "PRZR SURGE VALVE (MV1) FAILS CLOSED";
- (4) in "NORMAL" OUC Mode lower generator output to 50% at a rate of 0.5%FP/sec;
- (5) record and explain the changes in the following parameters.

PARAMETER	START	2 min	5 min	10 min	End
Reactor Neutron Power					
Heat Transport (ROH) Pressure					
Pressurizer Pressure					
Pressurizer Level					
Bleed Condenser Pressure					
Bleed Condenser Level					
Feed Flow					
Bleed Flow					
Storage Tank Level					

ASSIGNMENT:

- (a) What is the consequence of this malfunction if there is no change in reactor power level?
- (b) What is the consequence of this malfunction when the power level is changed?
- (c) What corrective action should the unit operator take?

4.5 PHT BLEED VALVE (CV5) FAILS OPEN

- (1) Initialize the Simulator to the 100% full power state;
- (2) record the initial parameter values;
- (3) insert malfunction "PHT BLEED VALVE (CV5) FAILS OPEN";
- (4) record and explain the changes in the following parameters.

PARAMETER	START	2 min	5 min	10 min	End
Reactor Neutron Power					
Heat Transport (ROH) Pressure					
Pressurizer Pressure					
Pressurizer Level					
Bleed Condenser Pressure					
Bleed Condenser Level					
Feed Flow					
Bleed Flow					
Storage Tank Level					

ASSIGNMENT:

- (a) What are the initial consequences of the increased Bleed flow?
- (b) Which control system responds to correct the excess Bleed flow? What is the controller action?
- (c) What corrective action could the unit operator take?

5. STEAM AND FEEDWATER SYSTEM EXERCISES

5.1 FW LCV101 FAILS OPEN

- (1) From a Simulator Initial state of 100% full power, insert the malfunction "FW LCV101 FAILS OPEN";
- (2) observe unit response on "Steam Generator Level Control" and "Steam Generator Level Trend" displays.

ASSIGNMENT:

- (a) What are the main system responses?
 - (b) What would the Operator need to do to maintain power production?
-
- (3) Repeat the above but view only the "Plant Overview" page until the alarm "Stm Gen Level Hi" is received.
 - (4) Take the appropriate Operator actions to maintain power production.

5.2 FW LCV101 FAILS CLOSED

- (1) Initialize the Simulator to 100 %FP;
- (2) change 'Control Mode Select' to OPERator and select 3-ELEment control for SG1 and SG3;
- (3) for SG1 change selection of LCV from #3 to #1;
- (4) after feedwater and boiler level transients are over, insert malfunction "FW LCV101 FAILS CLOSED".

ASSIGNMENT:

- (a) Explain the responses of feedwater flow, steam flow and pressure, and boiler level on all four steam generators.

- (5) Initialization the Simulator to 100 %FP;
- (6) change 'Control Mode Select' to OPERator and select 1-ELEment control for SG1 and SG3;
- (7) for SG1 change selection of LCV from #3 to #1;
- (8) after feedwater and boiler level transients are over, insert malfunction "FW LCV101 FAILS CLOSED".

ASSIGNMENT:

- (b) Explain the responses of feedwater flow, steam flow and pressure, and boiler level on all four steam generators.
- (c) Explain the main differences in response between (a) and (b).

5.3 STEAM GENERATOR #1 FW FT IRRATIONAL

- (1) Initialize the Simulator to 100 %FP;
- (2) insert malfunction "STEAM GENERATOR #1 FW FT IRRATIONAL".

ASSIGNMENT:

- (a) Explain the responses of feedwater flow, steam flow and pressure, and boiler level on all four steam generators.
- (b) What would be the correct operator action?

- (3) Initialization the Simulator to 100 %FP;
- (4) insert malfunction "STEAM GENERATOR #1 FW FT IRRATIONAL";
- (5) perform the correct operator action.

ASSIGNMENT:

- (c) Explain the responses of feedwater flow, steam flow and pressure, and boiler level on all four steam generators.
- (d) Explain the main differences in response between (a) and (c).

5.4 STEAM GENERATOR PRESSURE CONTROL EXERCISE

Using Simulator pages 'Plant Overview', 'Turbine-Generator' and 'UPR', design a procedure to verify the following features of the Steam Generator Pressure Control program:

(1) the boiler pressure error at which the ASDVs open

(2) the boiler pressure error at which the CSDVs open

(3) the % reactor power to which the steam flow through 100% open ASDVs corresponds

- final reactor power
- final generator power
- % reactor power through ASDVs
- governor valve opening

ASSIGNMENT:

Describe your procedure and record the results.

5.5 REACTOR TRIP AND UNIT RECOVERY

- (1) Initialize the Simulator to 100 %FP;
- (2) manually Trip the Reactor;
- (3) confirm Reactor Trip (neutron power decreasing rapidly, all shutdown rods in the core);
- (4) once Neutron Power is below 0.01 %FP and Turbine speed is at 5 RPM, begin power recovery operation;
- (5) reset Reactor Trip;
- (6) raise Reactor Power to 10 %FP, using the following rates of power level setpoint increases:

<u>Actual Neutron Power</u>	<u>Rate of Target Increase</u>
N < 0.5 %FP	0.01 %FP/sec
0.5 < N < 5 %FP	0.1 %FP/sec
5 < N < 10 %FP	0.2 %FP/sec

- (7) reset Turbine Trip, select 'TRU ENABLE', synchronize the generator and load to about 10 %FP;
- (8) in ALTERNATE mode raise Reactor Power and Generator Power to a level determined by the number of Adjuster Rod banks not fully in the core:
FINAL POWER = 100%FP - (5 x number of rod banks not fully in core)%

ASSIGNMENT:

- (a) Record the reactor (%FP) and generator power level (%FP and MW) reached when power recovery has been completed.
- (b) Ensure that for the allowed reactor power the generator is producing the maximum power.
- (c) How many Adjuster Rod banks were not fully in the core when the maximum power production recorded in (b) was achieved?

6. OVERALL UNIT EXERCISES

Begin each of the following exercises from the Plant Overview page. Initialize the Simulator to 100% FP. Before inserting the specific malfunction, change the plot parameter limits as follows:

Reactor Power minimum value	80 %
Turbine Power minimum value	80 %
Main Steam Header Pressure lower limit	4000 kPa
Pressurizer and ROH Pressure lower limit	9000 kPa
Pressurizer level and Setpoint	6 m

After inserting the malfunction (use a 5 second delay), note the main system responses, and how you can identify each malfunction, or at least identify the system (and simulator display) where the malfunction is most likely to be found.

6.1 FAIL CLOSED ALL FEEDWATER LEVEL CONTROL VALVE MOTORIZED VALVES

- (1) Observe the main parameter changes that take place in the first minute, in particular Reactor Neutron and Thermal Power, Pressurizer Level and Setpoint, Boiler Levels, PRZR/ROH Pressure, Steam Generator Pressure, Feedwater Flow.
- (2) Once Reactor Setback is initiated, freeze the simulator.

ASSIGNMENT:

- (a) Describe the main parameter changes including the above, and write a brief explanation for the parameter changes in terms of the process system responses and the control system responses.
- (3) Unfreeze (RUN) the simulator and clear the malfunction.
- (4) Place each SG level control MV on Manual and OPEN.

ASSIGNMENT:

- (b) In what sequence should the MVs be open? Why?
- (5) Raise reactor power and generator output to 100% FP and return to Turbine-leading-Reactor mode of unit control.
- (6) Check that all equipment states and parameter values are consistent with 100% FP condition.

6.2 ALL MAIN BFPs TRIP

ASSIGNMENT:

Describe the unit's response and explain the main differences between the responses to this malfunction and the one in exercise 6.1.

6.3 TURBINE SPURIOUS TRIP

ASSIGNMENT:

- (a) List the initial alarms after the malfunction had been inserted.
- (b) Describe the “state” (main energy balance) of the unit.
 - Reactor Power
 - Heat Transport ROH Pressure
 - Steam Generator Pressure
 - Generator output

One minute after inserting the malfunction, freeze the simulator.

- (c) Describe the response and effect of each of the main control programs:
 - BPC
 - UPR
 - RRS
 - TRU
 - BLC
 - PHTP&I
 - PRZR Level

Run the simulator for 5 minutes and again observe the response and effect of each of the main control programs.

- (d) Briefly describe and explain the response and effect of each of the main control programs. Note the value of key parameters after one and further five minutes.
- (e) What operator actions are required?

Remove the malfunction and return the unit to maximum generator output permitted by the reactor (i.e. 100 %FP - 5% for each Adjuster bank not fully in the core).

- (f) What was the maximum power level reached above and how many Adjuster Rod banks were not fully in the core?

6.4 THROTTLE PT (PRESSURE TRANSMITTER) FAILS LOW

ASSIGNMENT:

- (a) List the initial alarms after the malfunction had been inserted.
- (b) Describe the “state” (main energy balance) of the unit:
 - Reactor Power
 - Heat Transport ROH Pressure
 - Steam Generator Pressure
 - Generator output
- (c) Observe and explain the response and effect of each of the main control programs:
 - BPC
 - UPR
 - RRS
 - TRU
 - BLC
 - PHTP&I
 - PRZR Level

When Main Steam Header Pressure recovers to < 5000 kPa, Clear the malfunction.

Raise Reactor power to 60 %FP.

Reset turbine trip.

Load generator to 60 %FP.

- (d) Explain what further steps and precautions you would take in raising unit output to 100%FP.

6.5 RIH#1 SMALL BREAK

- (a) List the initial alarms after the malfunction had been inserted.
- (b) Describe the “state” (main energy balance) of the unit.
 - Reactor Power
 - Heat Transport ROH Pressure
 - Steam Generator Pressure
 - Generator output
- (c) Observe and explain the response and effect of each of the main control programs:
 - BPC
 - UPR
 - RRS
 - TRU
 - BLC
 - PHTP&I
 - PRZR Level
- (d) What specific Heat Transport System parameter(s) identify the loss of coolant from the main circuit?

After the malfunction is identified (5 - 10 minutes) remove the malfunction and return the unit to full power operations.

- (e) Explain what precautions you would take in raising unit output to 100%FP.

6.6 MAIN STEAM HEADER BREAK

- (a) List the initial alarms after the malfunction had been inserted.
- (b) Describes the “state” (main energy balance) of the unit.
 - Reactor Power
 - Heat Transport ROH Pressure
 - Steam Generator Pressure
 - Generator output
- (c) Observe and explain the response and effect of each of the main control programs:
 - BPC
 - UPR
 - RRS
 - TRU
 - BLC
 - PHTP&I
 - PRZR Level
- (d) What specific Steam System parameter(s) identify the loss of steam from the system?