

TITLE
ICTP-IAEA project | (smr 3562)

Abdulwahhab Essa

University Kebangsaan Malaysia



The Abdus Salam
**International Centre
for Theoretical Physics**
www.ictp.it



IAEA

International Atomic Energy Agency
Atoms for Peace



UNIVERSITI
KEBANGSAAN
MALAYSIA
*The National University
of Malaysia*



Date of Presentation : 19/2/ 2021

Hardware system

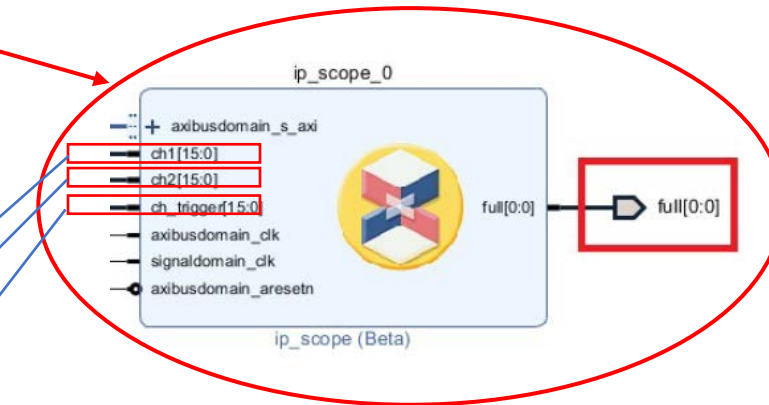
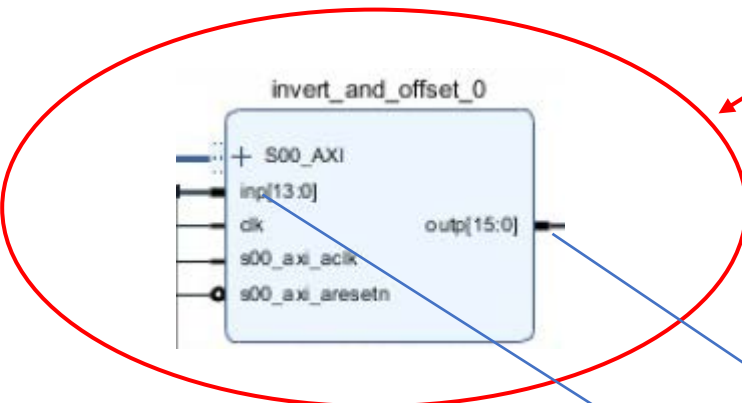
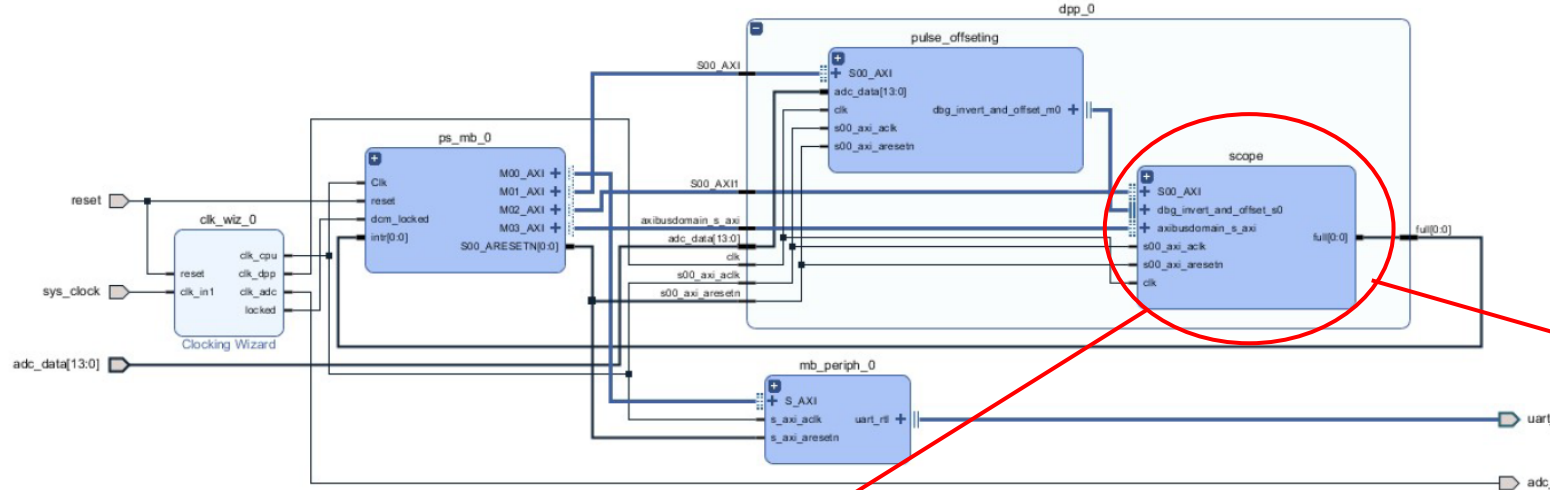

Result of the lab

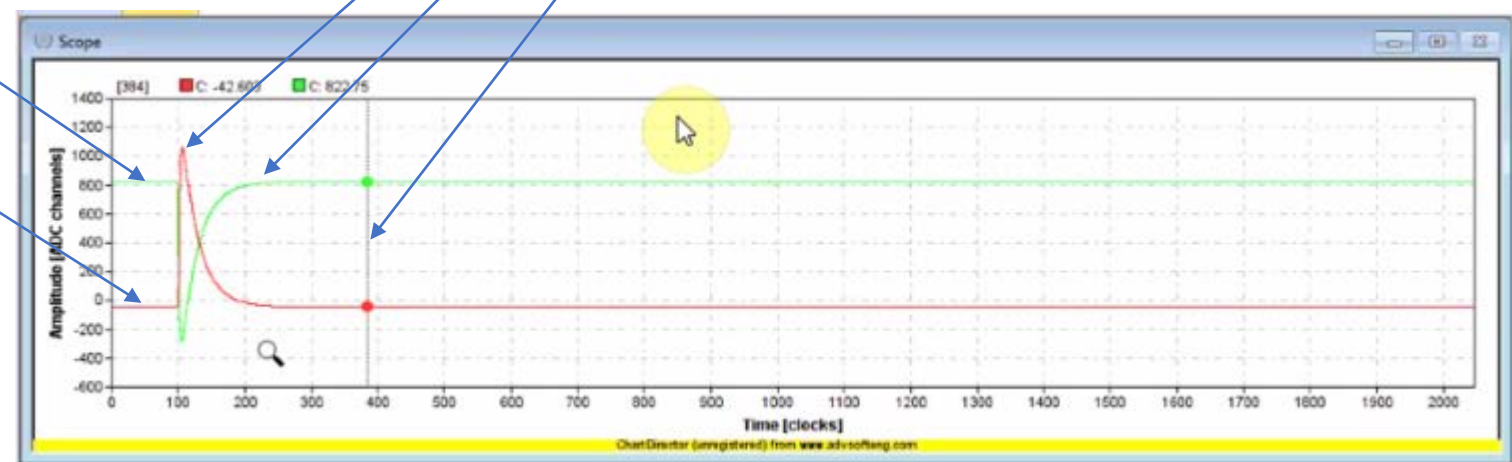

Summary of what I learn from the school

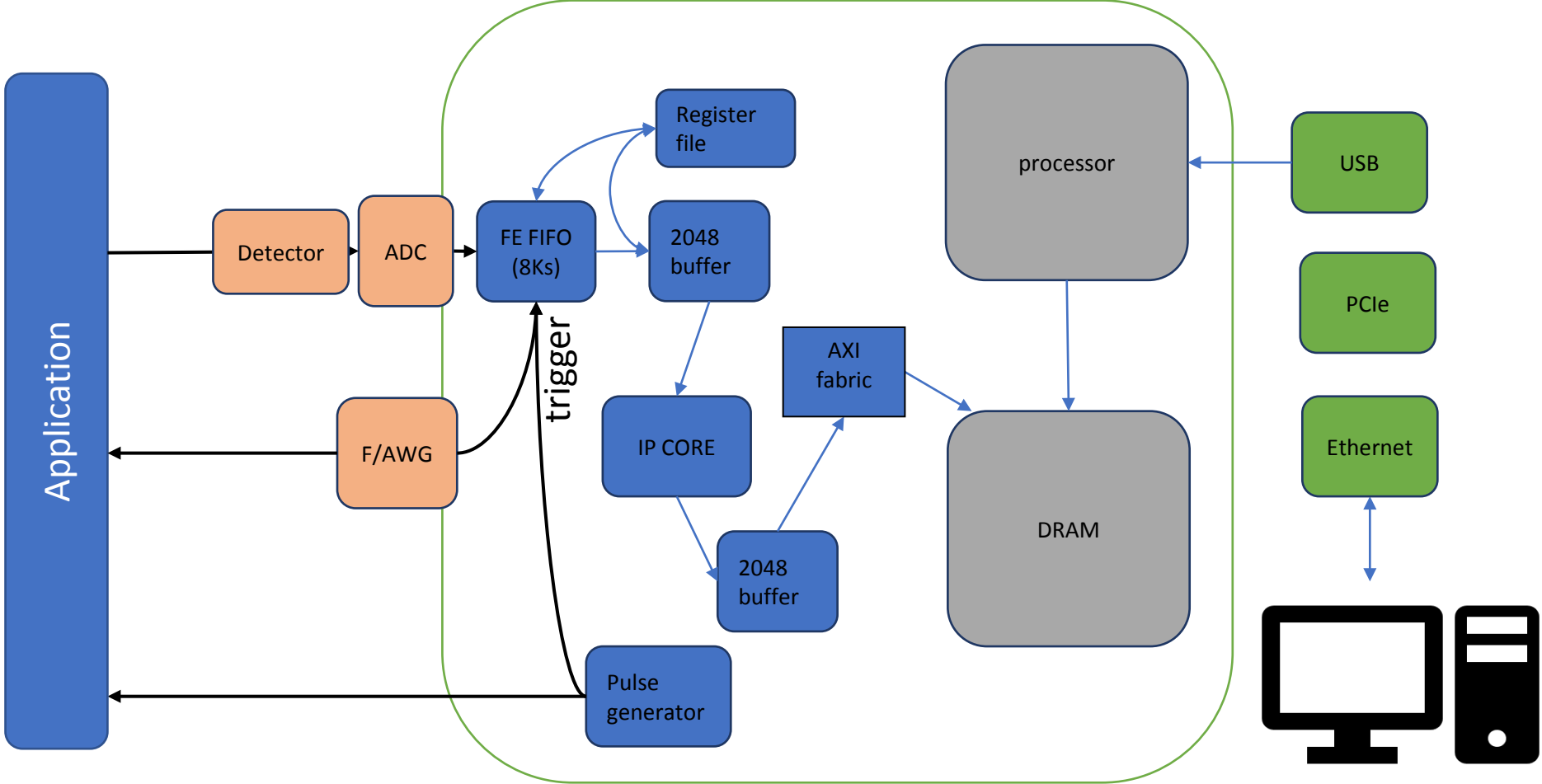

System 1

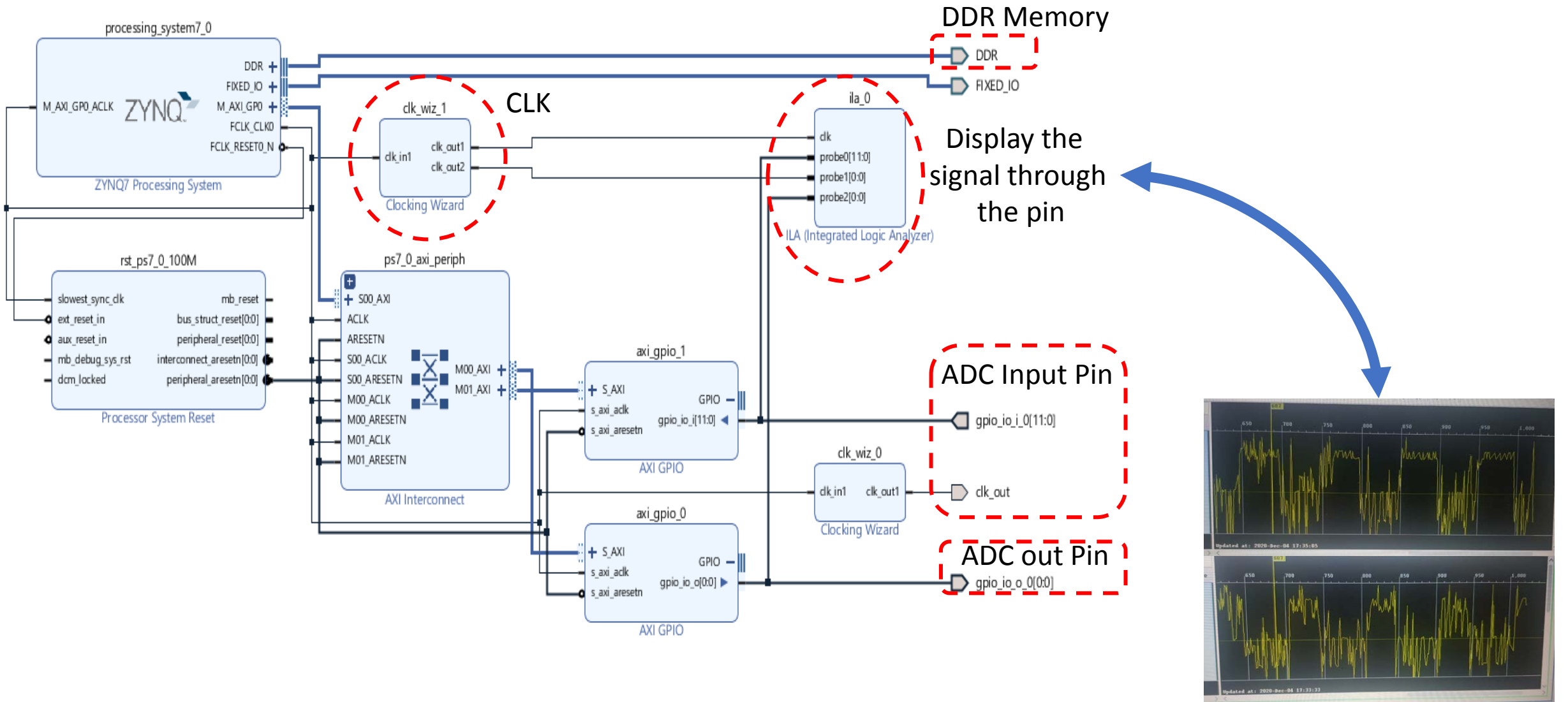

System 2: Block diagram of ADC-FMC card with SoC

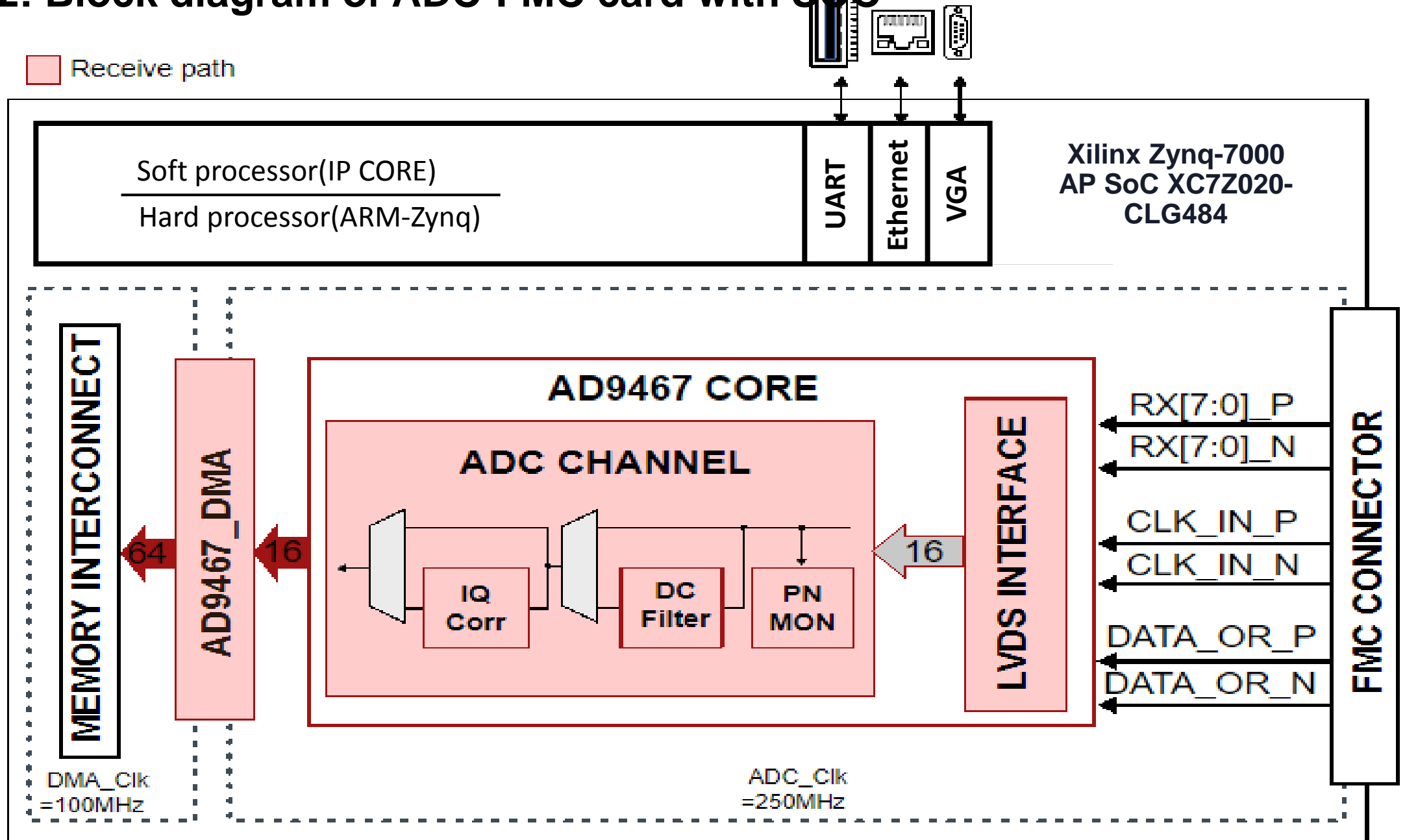

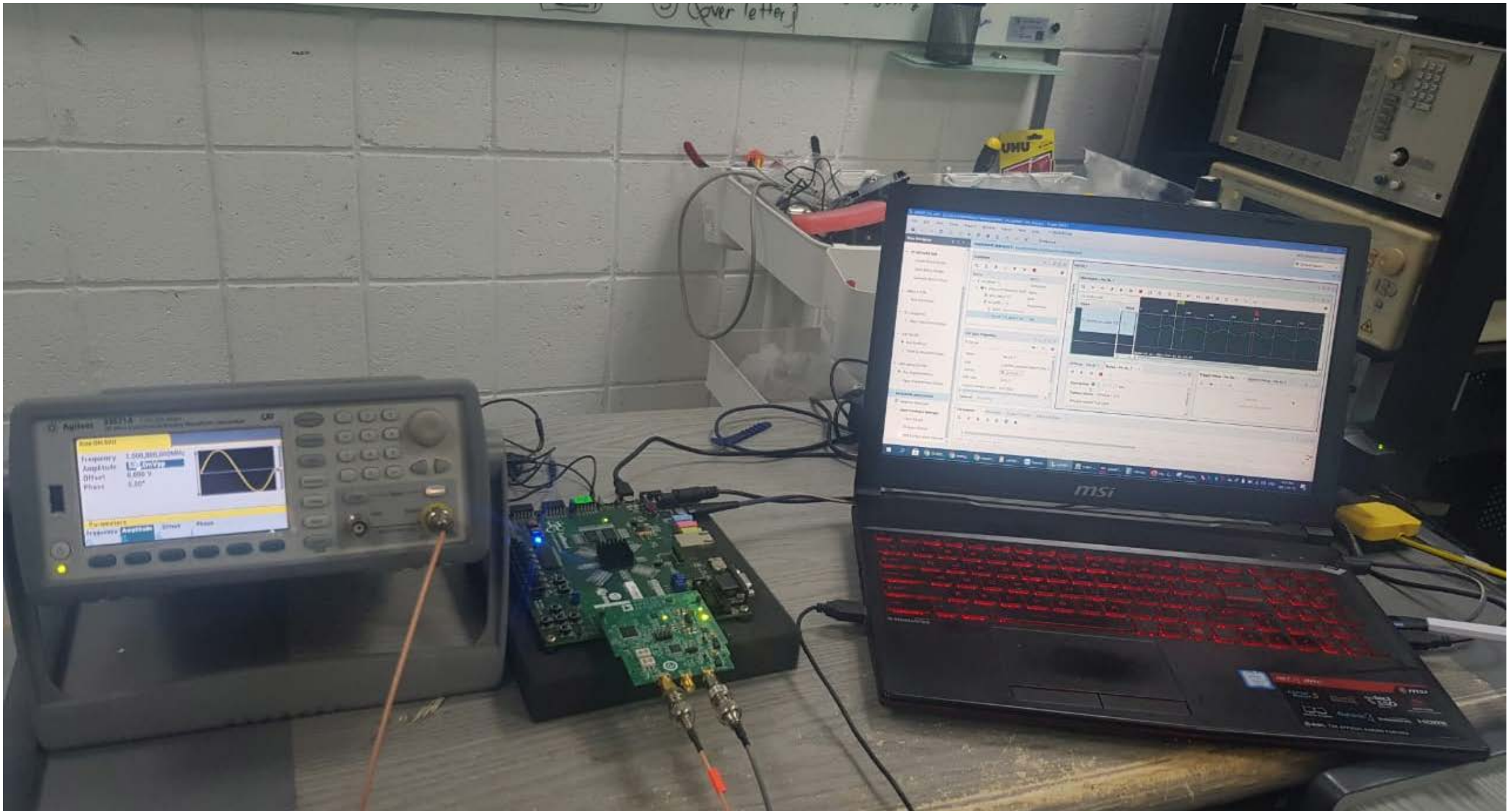

System 2

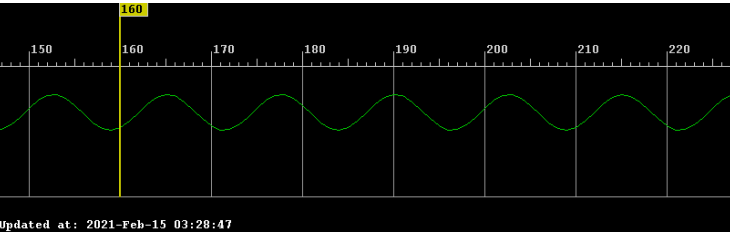

Sine wave signal
10MHZ, 1V

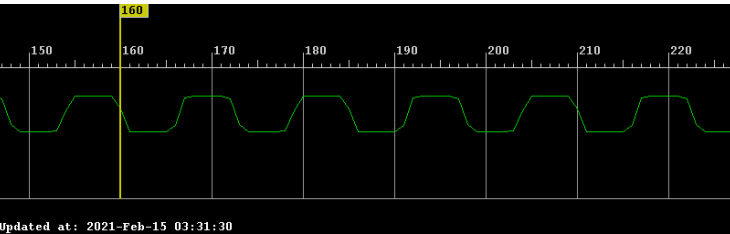

Square signal
10MHZ, 1V

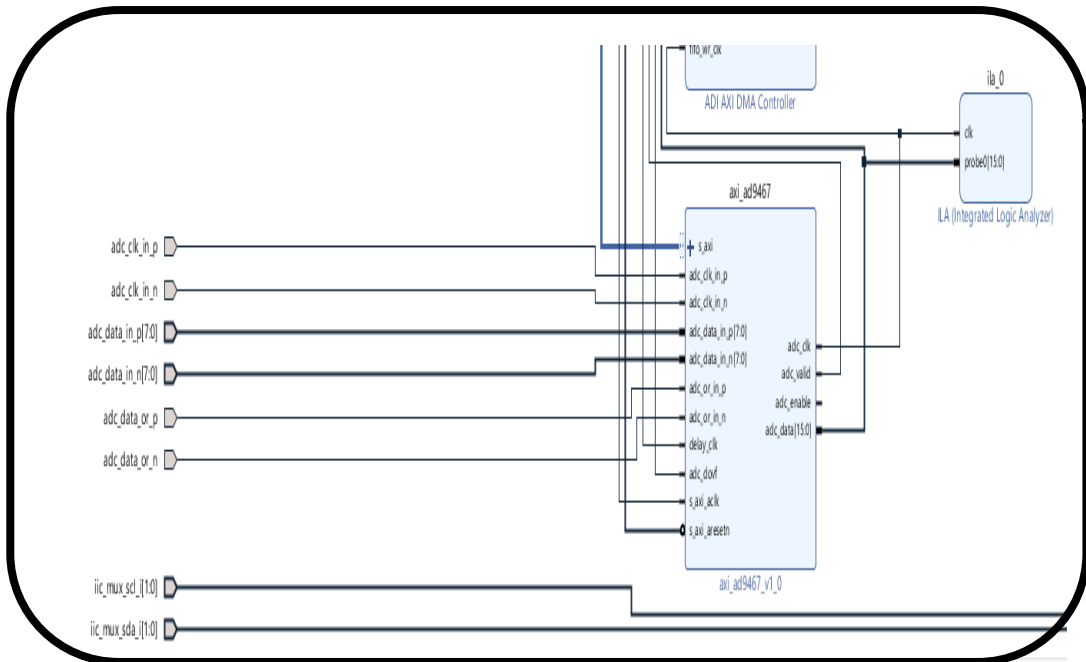
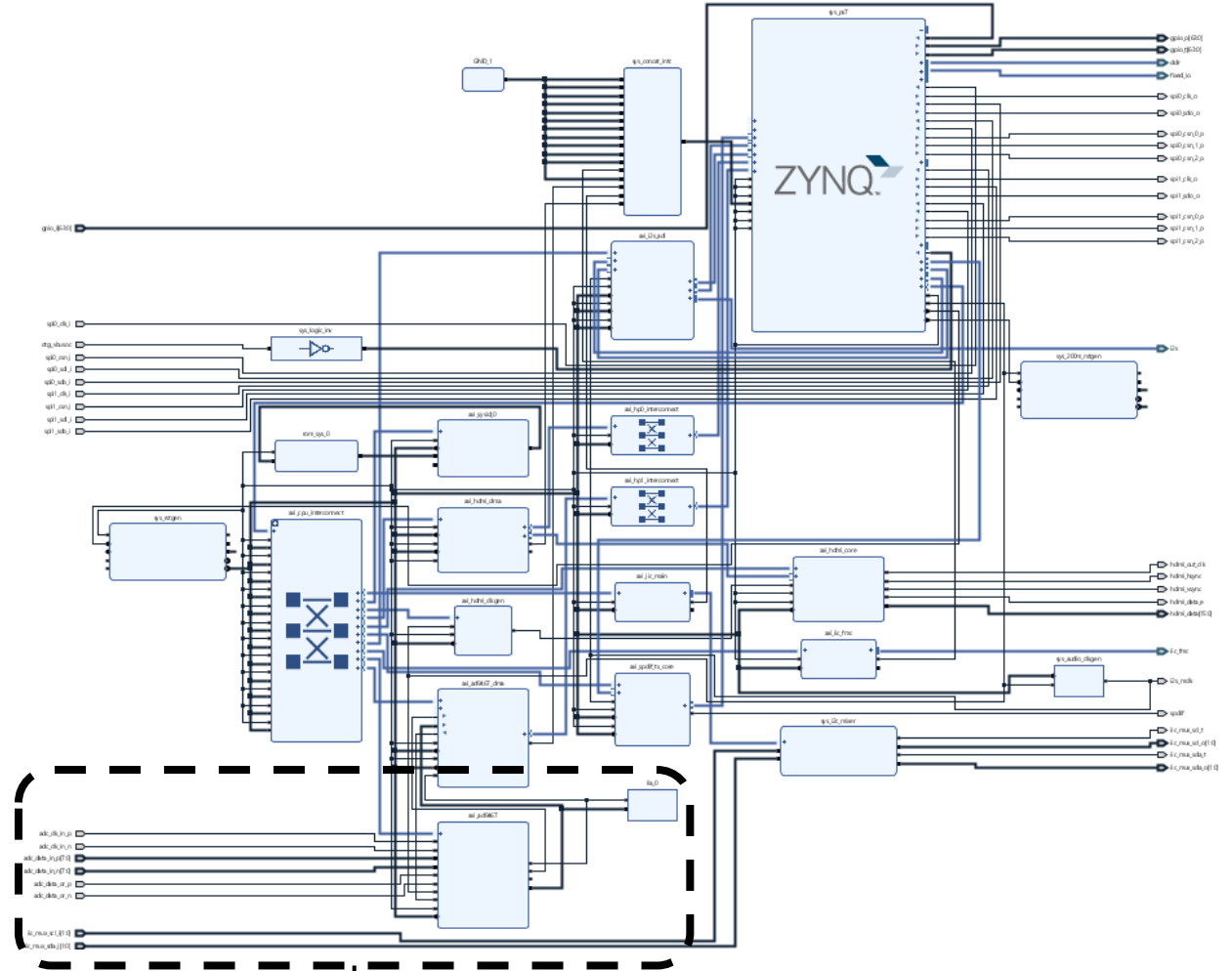

- **Project activity you prefer and consider more relevant for your research**
- **New topics learned during project activities sessions**

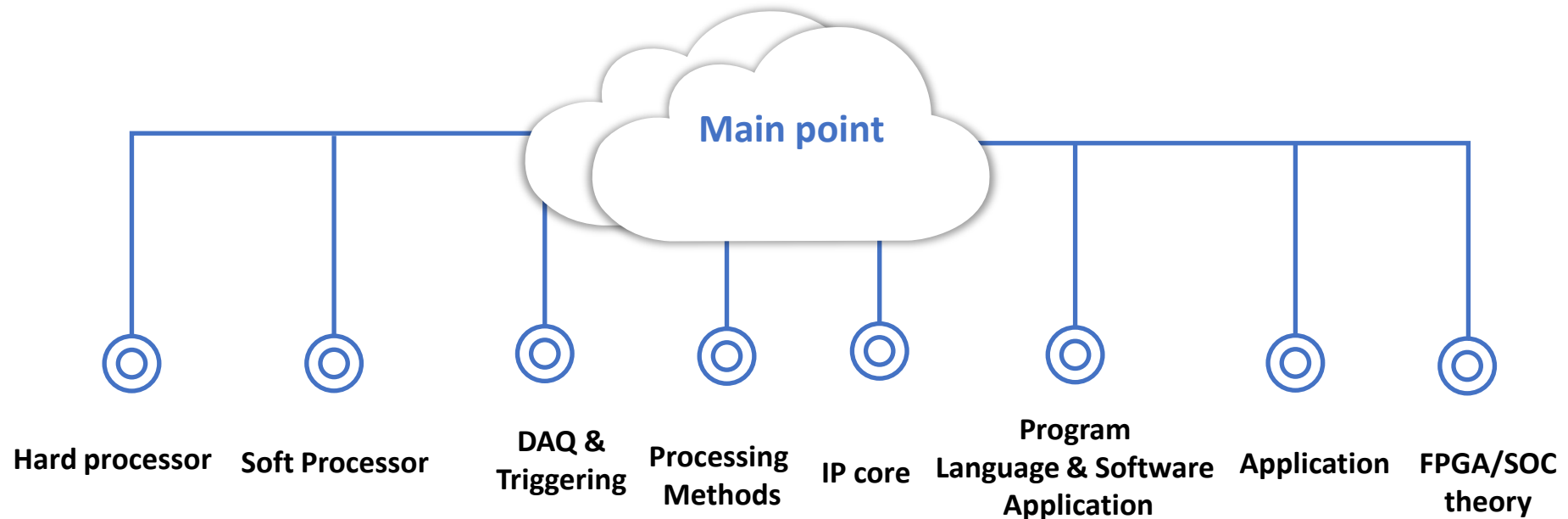

Difficulties and challenges afforded

- program language
 - VHDL
 - C,C++
- Discover new software application in short time.
- Learn new mathematical method in short time.

2021

THANK YOU !