

Workshop on
**Nuclear Reaction Data and Nuclear Reactors:
Physics, Design and Safety**

13 March - 14 April 2000

Miramare - Trieste, Italy

*Design, Principles, Targets and Criteria for a
Multipurpose Advanced Reactor
Inherently Safe (MARS).
Evaluation of the Total Production Cost of Electric
Energy*

M. Cumo
University of Rome "La Sapienza"
Italy



**DESIGN PRINCIPLES, TARGETS AND CRITERIONS FOR A
MULTIPURPOSE ADVANCED REACTOR INHERENTLY SAFE (MARS).
EVALUATION OF THE TOTAL PRODUCTION COST OF ELECTRIC
ENERGY**

M. CUMO
University of Rome "La Sapienza"
Department of Nuclear Engineering and Energy Conversion
Corso Vittorio Emanuele II 244
00186 Rome, Italy
E-Mail cumo@dinceall.din.uniroma1.it

To be accepted and to be, sooner or later, extensively utilized, a new technology must respect the nature and its equilibria.

For a nuclear power plant, the full respect of nature and of its equilibria means: for normal operation of the plant, guaranteeing a radiological impact comparable to the standard deviation of the radioactive natural background; for worst design plant accidents, guaranteeing an external impact only with the same probability as that of ultra-catastrophic natural events, such as bolide impacts to the earth.

In compliance with Prof. A. Weinberg's suggestions, the design of the MARS nuclear plant was conceived according to this philosophy.

The main factors which have affected the design development process of the MARS nuclear plant are introduced in the following. They include design principles, design targets and design criteria.

These factors will be presented in two groups: the first group refers to the most relevant ones, regarding project fundamentals, as design principles, targets and main criteria (paragraph 1).

The second group refers to detailed design criteria adopted for systems, structures and components relevant to safety (paragraph 2).

1 Project fundamentals: design principles, design targets and main design criteria

1.1 Basic design principles

The design of the MARS nuclear reactor stands on basic principles described in the following.

Safety-related principles

They include:

- in-depth defense against radiological hazard for personnel and the population

- capability of the plant to handle any kind of accident, including severe accidents
- reliance on physical laws not only to detect safety requirements, but also to perform the safety action itself, which means extensive utilization of “inherent” and “exhaustive” safety features
- “insensibility” of plant safety to human errors and faulty actions

Non safety-related principles

They include:

- the MARS nuclear plant is intended to be marketed as a nuclear plant allowing:
 - multi-purpose utilization
 - extremely short construction time
 - easy and fast plant testing
 - easy removal of faulted components and simple, fast and complete decommissioning
 - easy operation and maintenance
 - extremely low doses to personnel
 - extremely reduced production of nuclear wastes (excluding fuel).
- The purpose of the MARS nuclear plant design is to cope with the principle of making the plant construction, maintenance and decommissioning similar to those for gas-fueled plants: the MARS nuclear plant must include mainly mechanical components, manufactured according to severely controlled but fast procedures in shop, tested in shop, to be rapidly assembled at the final site, with simple and fast final inspections.

1.2 Design targets

The main targets of the design of the MARS nuclear reactor include safety, performance and cost targets.

Safety targets

These include the following:

- by definition the design must be such that core coolability must be always guaranteed. This means that no loss of primary coolant must be envisaged [catastrophic events may be anticipated, but the possibility of primary coolant losses into the reactor building must be recognized as realistically “impossible”, and only assuming the occurrence of at least two independent mechanical failures on static components or of, at least, three independent mechanical failures on components including non static ones (but never active-type)];

- doses to operation and maintenance personnel must be drastically lower than in traditional nuclear plants (by at least an order of magnitude);
- by definition the design must be such that no accident may be envisaged involving fast thermal transients in the nuclear fuel. All accidental transients involving the primary coolant and the reactor core must be slow-transients;
- steam generators [each module, i.e. each reactor, is equipped with one steam generator only] must operate at a temperature lower than the minimum temperature allowing stress corrosion in the tube bundle, for the selected tube material;
- ATWS must be eliminated through a back-up, passive-type scram system, operated according to different criteria from the main scram system.

Performance targets

These include the following:

- the neutron economy shall be such as to allow, with initial enrichment typical of traditional PWRs, an overall irradiation time of fuel of at least;
- the thermal power generated in the core for each plant module must be between 100 and 700 MW (these limits are only indicative; wider ranges might be assumed);
- the boron content in the primary coolant must be lower than 800 ppm at the beginning of cycle (to minimize boron cycle treatments problems).

Cost targets

These include the following:

- the cost of energy produced by the MARS plant shall be competitive with energy produced through fossil-fueled plants at current prices;
- the cost of energy produced by the MARS nuclear plant must be competitive even at rather low installed powers (50 to 200 MWe);
- the highest percentage of cost of produced energy must refer to depreciation of the investment cost, which means an incentive to qualified employment in manufacturing factories and at the site (the cost of fuel is the same as that of PWR fuels with the same enrichment, with a very wide supply market).

1.3 Main design criteria

The main design criteria are listed below.

Main safety design criteria

These include:

- the use of proven nuclear inherent-safety features must be systematic;
- the probability of core protection function failure must be substantially reduced with respect to traditional nuclear plants. Therefore, an extensive use of static safety systems shall be made; active safety systems shall be avoided for the post-accident coolability of the core;
- the main initiating events and/or causes of nuclear accidents shall be eliminated *a priori* (in-depth prevention criterion); the nuclear system shall be designed so as to show an “inherent” capability to avoid fuel damage;
- the safety systems of the plant shall be completely testable during plant operation;
- safety features shall be based on “easy to understand” physical laws for public acceptability and on components whose intervention cannot be jeopardized.

Main market-oriented design criteria

These include:

- the design of plants and components has to meet the requirement of minimizing the construction time and assuring the fulfillment of the construction scheduling. For this purpose, the design shall be greatly simplified; in-site works shall be drastically limited; in-shop activity shall be maximized, with in-site activity mainly limited to final assembling of pre-assembled components and systems;
- the plants, circuits and buildings will be designed so as to facilitate plant modularity (station growth scheduled according to demand growth) and to facilitate alternative uses of the heat produced (multi-purpose design);
- the design shall be highly insensitive to the site requirements (plant siting independence). This could also lead to new perspectives in licensing criteria, with drastic simplification of licensing and control activities;
- the operation of the plant shall be highly reliable. Also, innovative safety solutions shall demonstrate their capability not to affect production reliability;
- plant components shall be, as far as possible, of limited size (lower cost; higher possibility for manufacturer selection), provided the scale-effects on costs do not negatively affect this criterion;
- major constraints and problems concerning the design and construction of the reactor building, which highly affect the cost and length of nuclear plant construction, shall be thoroughly analyzed and - possibly - eliminated;
- plant simplification shall be pursued, through the removal of requirements for active-type safety actions; the drastic limitation of active components to be maintained shall be such as to allow less severe requirements in personnel qualification;
- the design shall be such as to allow a drastic limitation in safety-class system and component standard requirements;

- doses to personnel and nuclear waste production shall be minimized.

1.4 Detailed design criteria for systems, structures, equipment relevant to safety

The general design criteria listed in paragraph 1 have been translated into detailed design criteria for systems, structures, equipment. In the following paragraphs detailed design criteria are listed only with reference to systems, structures and components which play a fundamental role in plant safety ("relevant to safety").

1.5 Design objectives

The application of the detailed design criteria is based on a series of classifications (see paragraphs 2.2, 2.4).

These classifications are utilized to select the design, construction and assembling standards of each component, system or structure, depending on the requirement, to perform an action which is needed to guarantee plant safety or the requirement, that it not negatively affect an action of other components/systems, which are relevant to plant safety.

The safety objectives considered for plant safety are:

1. the nuclear reactor shutdown is to be assured and the reactor is to be maintained in safe shutdown conditions;
2. the structural integrity of the primary coolant pressure boundary or of the pressurized containment is to be assured;
3. a proper core cooling is to be assured;
4. the radiological consequences of accidents are to be prevented and, if any, they have to be properly mitigated.

The specification of the various design objectives is reported in paragraph 2.3.

1.6 Plant conditions

Plant conditions have been identified in order to differentiate the requirements of components, systems and structures in guaranteeing plant safety.

The safety objectives listed in paragraph 2.1 must be reached in any plant condition, either normal operational condition or accidental condition. The degree of compliance of safety objectives changes with the various plant conditions, as specified in paragraph 2.3.

The classification of plant conditions follows the ANSI/ANS N18.2 as far as conditions with a probability higher than $1 \cdot 10^{-4}$ are concerned (up to Level 4 plant condition); since the MARS plant design has been developed with the aim of guaranteeing core coolability and the other safety objectives for plant conditions characterized by a probability much lower than $1 \cdot 10^{-4}$, an Additional Level has been

introduced, which is not considered in the ANSI/ANS N18.2. Furthermore, another level has been introduced, for severe accident scenarios (Severe Accident Level), to address specific design criteria which are aimed at the management of such extreme plant conditions, also aimed at guaranteeing the fulfillment of very strict safety targets for plant personnel and population.

- Level 1
Level 1 conditions include all normal and planned conditions which may occur during start-up, shutdown, power operation, refueling and maintenance.
- Level 2
Level 2 conditions include unplanned events; the occurrence probability of these conditions is higher than $3 \cdot 10^{-2}$ events/year.
- Level 3
Level 3 conditions include rare events; the occurrence probability of these conditions is in the range $3 \cdot 10^{-2}$ to $1 \cdot 10^{-3}$ events/year.
- Level 4
Level 4 conditions include events that are not foreseen to occur during the plant life, but are nevertheless taken into consideration as design events; the occurrence probability of these conditions is in the range $1 \cdot 10^{-3}$ to $1 \cdot 10^{-4}$ events/year.
- Additional Level
This Level has been introduced for the MARS plant owing to its peculiar characteristics which allow the plant to face harmful events with a probability which is considerably lower than $1 \cdot 10^{-4}$. Additional Level conditions, by definition, include events that are not foreseen to occur during plant life, but nevertheless they are taken into consideration as design events; the occurrence probability of these conditions is in the range $1 \cdot 10^{-4}$ to $1 \cdot 10^{-7}$ (since in the range $1 \cdot 10^{-6}$ to $1 \cdot 10^{-7}$ the influence of common mode failures with natural ultra-catastrophic events becomes relevant, just for practical reasons of plant design the reference range of the Additional Level should be considered $1 \cdot 10^{-4}$ to $1 \cdot 10^{-6}$).
- Severe Accident Level
This level has been introduced for the MARS plant because of its peculiar characteristics, which allow a safe management of the plant even during non-foreseeable plant conditions with extended nuclear fuel damage. The occurrence probability of such conditions cannot be assessed utilizing standard probability assessment approaches, because of their extremely low values. For theoretical reference, (useful for design purposes and leaving aside common failures which depend on ultra-catastrophic natural events) and for the scope of these definitions, a probability range with values lower than $1 \cdot 10^{-9}$ may be assumed for this Severe Accident Level.

1.7 *Specification of design objectives for the various plant conditions*

Specifications of the design objectives listed in paragraph 2.1, and for the various plant conditions listed in paragraph 2.2 are provided below.

- Level 1
Design objective n° 1 is to be guaranteed by the standard, active-type, core shutdown system.
Design objective n° 2 is to be guaranteed for both the primary coolant (RCS) pressure boundary and for the pressurized containment (CPP).
Design objective n° 3 is to be guaranteed in depth, which means that fuel cladding shall be always in contact with core coolant in liquid phase.
Design objective n° 4 is to be guaranteed in depth, which means that any radiological consequence shall be prevented. The maximum organ dose shall be kept below the dose value due to the standard deviation of the natural radioactive background level (in Italy, 30 mrem/year).
- Level 2
Design objective n° 1 is to be guaranteed by the standard, active-type, core shutdown system.
Design objective n° 2 is to be guaranteed for both the primary coolant (RCS) pressure boundary and for the pressurized containment (CPP).
Design objective n° 3 is to be guaranteed assuring that the fuel cladding is always in contact with core coolant, with a single-phase or a two-phase flow, but with a maximum void fraction in the core lower than 0.3. The minimum DNBR in the core shall be higher than 3¹.
Design objective n° 4 is to be guaranteed in depth, which means that any radiological consequence shall be prevented. The maximum organ dose shall be kept under the dose value due to the standard deviation of natural radioactive background level.
- Level 3
Design objective n° 1 is to be guaranteed by the standard, active-type, core shutdown system.
Design objective n° 2 is to be guaranteed, with the exception of the possibility of rupture of a single tube of the steam generator.
Design objective n° 3 is to be guaranteed assuring that the fuel cladding is always in contact with core coolant, with a single-phase or a two-phase flow, but with a maximum void fraction in the core lower than 0.5. The minimum DNBR in the core shall be higher than 3.

¹ The values selected for minimum DNBR design objectives are higher than reference values commonly utilized for traditional PWRs licensing. This choice was also due to the discrepancies in DNBR prediction by various existing correlations.

Design objective n° 4 is to be guaranteed assuring that the maximum effective dose equivalent to the critical population individual is lower than 0.5 rem/event and the maximum single organ dose to critical population individual is lower than 1.5 rem/event.

- Level 4

Design objective n° 1 is to be guaranteed by the standard, active-type, core shutdown system.

Design objective n° 2 is to be guaranteed, with the exception of the possibility of rupture of a single tube of the steam generator.

Design objective n° 3 is to be guaranteed assuring that the fuel cladding is always in contact with core coolant, with a single-phase or a two-phase flow, but with a maximum void fraction in the core lower than 0.7. The minimum DNBR in the core shall be higher than 2.

Design objective n° 4 is to be guaranteed assuring that the maximum effective dose equivalent to the critical population individual is lower than 0.5 rem/event and the maximum organ dose is lower than 1.5 rem/event.

- Additional Level

Design objective n° 1 is to be guaranteed by at least one of the two core shutdown systems (the active-type scram system, or the passive-type scram system).

Design objective n° 2 is to be guaranteed for at least one of the two barriers: the primary coolant (RCS) pressure boundary or the pressurized containment (CPP) boundary.

Design objective n° 3 must be satisfied assuming that the fuel cladding is always in contact with core coolant, even in two-phase flow, and the minimum DNBR is higher than 2.

Design objective n° 4 is to be guaranteed assuring that the maximum effective dose equivalent to the critical population individual is lower than 0.5 rem/event and the maximum organ dose is lower than 1.5 rem/event.

- Severe Accident Level

Design objective n° 1 is not applicable; nevertheless, the design of reactor vessel internals and of reactor cavity shall be such to guarantee that no criticality condition for the relocated core will occur.

Design objective n° 2 is not applicable.

Design objective n° 3 is to be guaranteed, in the sense that a proper coolant (not the RCS coolant) flow must be foreseen to maintain the relocated core in a stable geometrical condition, with a continuous removal of the decay heat that must be transferred to the external atmosphere.

Design objective n° 4 is to be guaranteed assuring that the individual effective dose equivalent is lower than 1 rem during the first 36 hours of the accident, without any external protective action, and lower than 5 rem during the whole accident evolution, with no external protective action. During one year following the end of the accident, the integrated individual effective dose

equivalent shall be lower than 2 rem. The integrated dose to the individual for all his/her life shall be lower than 10 rem.

1.8 Structures, systems and components classifications

Safety classification

A safety classification has been adopted to address the detailed design and construction criteria for systems, structures and components, according to the relevance of their function as far as safety objectives are concerned.

The safety classification of systems and components includes two categories: the first refers to systems and components relevant to safety (RS - Relevant to Safety), the second refers to systems and components whose function does not involve safety aspects (NRS - Not Relevant to Safety).

This classification has been adopted according to ANSI/ANS 58.14.

To make the component design and construction criteria coherent with the safety classification, two additional classifications are also used for each component: quality level (QL) and seismic class (SC).

For RS components and systems, the higher level of QL and SC is assigned; only for those components which are subjected to ASME Boiler and Pressure Vessel Code requirements is a further classification adopted (see paragraphs below).

For NRS components, the minimum QL required is adopted; nevertheless, it corresponds to a high industrial standard; they are not required to meet the requirements of seismic class, unless their collapse would involve the damage of RS components and systems.

Quality level classification

Two quality levels are foreseen: QL1, (mandatory for RS components) and QL2, (which corresponds to a high industrial standard and requires a quality assurance based construction).

According to RG 1.26 and ANSI/ANS 58.14, for fluid systems the QL1 class is further divided into four sub-classes: QLA, QLB, QLC, and QLD.

- QLA is applicable to pressurized components (and to their supports) of the primary coolant (RCS) pressure boundary and of the residual heat removal system. Their rupture, neglecting the presence of the pressurized containment (CPP), would cause a loss of coolant able to affect the pressure control and the core coolant functions. These components must meet the requirements of ASME Boiler and Pressure Vessel Code, section III.
- QLB is applicable to components of the primary coolant pressure boundary and of the pressurized containment that are not classified as QLA. These components must meet the requirements of ASME Boiler and Pressure Vessel Code, section III.

- QLC is applicable to RS components not classified as QLA or QLB, but for which the ASME Boiler and Pressure Vessel Code, section III is applicable.
- QLD is equivalent to QL2 and is applicable to fluid systems; the requirements of the following codes have to be met:
 - ASME Boiler and Pressure Vessel section VIII for pressure vessels, heat exchangers and pump casings;
 - ANSI B31.1 for piping;
 - ANSI B16.34 for valves;
 - API 620 for low-pressure vessels.

Seismic classification

Three seismic classes are utilized:

- SC1 refers to components that are to face the earthquake design (SSE - Safe Shutdown Earthquake), combined with other loads, without any loss of their integrity, seal and function;
- SC2 refers to components not relevant to safety, whose structural collapse might, during or after the SSE, affect the functionality of SC1 components or would make it difficult to take actions to face post-accidental conditions. These components must guarantee the absence of their structural collapse during SSE and, in the case of fluid systems, the containment function must be guaranteed;
- NSC refers to components not classified as SC1 or SC2.

1.9 Design loads due to meteorological conditions

Wind

The action of wind will be evaluated at the detailed design stage, according to local laws, to assess wind loads on structures.

Tornado

The characteristics of design reference tornado, and of missiles it may produce, assumed for the MARS design are the following:

- tornado:
 - maximum rotational velocity 73.5 m/s
 - minimum rotational velocity 34.5 m/s
 - translational velocity 24 m/s
 - maximum pressure 0.06 bar
 - minimum pressure -0.07 bar
 - radius corresponding to max rot. velocity 45 m

- missiles:
 - vehicle
 - * weight 1000 kg
 - * impact velocity 12.25 m/s
 - * impact elevation up to 7 m
 - * impact area 2.1 m²
 - steel bar
 - * length 3 m
 - * diameter 7.5 cm
 - * weight 35 kg
 - * impact velocity 24.5 m/s
 - * impact elevation no limitation
 - * impact direction perpendicular to structure
 - wood pole
 - * dimensions 0.1 m x 0.3 m x 3.6 m
 - * weight 50 kg
 - * impact elevation no limitation
 - * impact area 0.3 m x 3.6 m

Lightning

Both overvoltage protections and local effect protections will be taken into consideration.

Main parameters selected for lightning protection are :

- storm days per year 40
- lightning density to the soil 7 lightnings/km²
- lightning parameters:
 - rise time 1 ms
 - maximum current 250 KA
 - energy 2 10⁷A²s
- soil resistivity 150÷300 Ω/m

1.10 Criteria for flood protection

Flooding does not affect the relevant design choices regarding safety-related systems and components. Therefore, it will be analyzed in detail only at the stage of preliminary design of a plant referred to a selected site. As general criteria, the following requirements will be adopted for SC1 components and structures.

External flooding

The plant access will be at an elevation 1 m above the maximum foreseeable flood level.

Since no effect will be caused by external flooding within the plant building, no safety aspect will be involved; only difficulties on external operations are foreseen.

The plant will be prudentially shutdown.

Internal flooding

The buildings will be subdivided into flood areas (FA); for each flood area, the internal flooding cause will be analyzed and the maximum water level will be evaluated.

In each flood area, the water level during an accidental transient with loss of water or during any fire protection system intervention shall not exceed 0.5 m, even adopting drainage systems.

RS components will be designed and installed to avoid any common mode failure due to flooding.

1.11 Criteria for missile protection

All SC1 and SC2 components and structures will be designed so as to guarantee protection against the following missile types:

- missiles generated by the plant:
 - missiles generated by the plant at the external side of the reactor building
 - missiles generated by the plant at the internal side of the reactor building
 - missiles generated by the turbine (if any)
- missiles generated by natural phenomena:
 - missiles generated by tornado
- missiles generated by human activity out of the site:
 - missiles generated by explosions
 - aircraft impact

As far as missiles generated by the plant are concerned, the following causes will be considered:

- rupture of pressurized components
- rupture of rotating components
- component drop
- other causes (explosions, etc.)

The plant will be subdivided into Missile Containment Areas (MCA), each able to face the effects of rupture of pressurized components and of rotating components.

Missile classification and description

Missiles generated by the plant outside the reactor building

Any RS (Relevant to Safety) component or system located externally to the reactor building shall be protected against missiles.

RS systems located outside the reactor building are:

- the control room, the electronic protection system, the emergency battery system
- the irradiated fuel handling and storage system
- the nuclear waste treatment systems.

In the halls hosting the control room, the electronic protection system, the emergency battery system and the irradiated fuel handling and storage system, no pressurized or rotating components are foreseen.

Component drop is foreseen only in the fuel building.

In the nuclear waste treatment system building, the physical separation of components, power centers and cables is adopted to avoid the propagation of any damage.

The nuclear waste treatment system building contains both pressurized and rotating components; also explosive substances are foreseen (e.g. hydrogen) and components handling is possible. The physical separation of components will be adopted together with the introduction of barriers against missiles.

Missiles generated by the plant within the reactor building

Within the reactor building, the following criteria are assumed:

- the only rotating components are the primary pump located inside the pressurized containment, and the HVAC fans, which are located in separate rooms. No missile from rotating components is foreseen.
- the pressurized components are designed according to the highest allowable quality level and therefore a missile production from their collapse is not foreseen. The expulsion of bolts or of instrumentation is taken into consideration to protect the plant.
- no explosive substances may be introduced into the reactor building.
- the handling system may be used only in shutdown conditions.

Missiles generated by the turbine-alternator group

No RS component will be located inside the turbine building.

Any turbine generated missile impact on other buildings is enveloped by the aircraft impact (see below).

Missiles generated by tornado

These have been considered among the design loads due to meteorological conditions.

Missiles generated by explosions

The impact of missiles produced by external explosions is enveloped by the reference aircraft impact (see below).

Aircraft impact

The aircraft impact plays the role of enveloping external impacts.

The reference aircraft impact missile has the following characteristics:

- weight 20,000 kg
- impact velocity 150 m/s
- impact area for penetration analysis 2.6 m²
- load diagram, versus time, on 7 m² area, for dynamic analyses:
 - time (ms) 0 15 60 >60
 - load (kg) 0 5·10⁶ 5·10⁶ 0

Structures to be protected against external missiles

The following structures shall be protected against external missiles (aircraft impact):

- reactor building
- pools and towers of the safety core cooling system
- control building
- fuel building;
- buildings containing portions of the primary system (RCS) auxiliaries
- buildings containing relevant radioactivity inventory

Structures protected against tornado missiles are all structures whose damage would cause plant conditions higher than Level 2.

1.12 Criteria for protection against dynamic effects associated with pressurized piping rupture

In the MARS plant, all SC1 and SC2 components will be protected against rupture of pressurized piping.

The systematic application of the Leak Before Break (LBB) methodology to all piping containing high energy fluids which are located inside the reactor building allows to limit the study of dynamic effects associated with pressurized piping rupture to a few circuits outside the same building.

If an analysis of dynamic effects associated with pressurized piping rupture is required, circumferential ruptures will be taken into consideration for piping with a diameter lower than 4", while longitudinal ruptures will be considered for piping with diameter higher than 4".

To localize rupture positions, seismic loads will not be taken into consideration; the loads considered are assessed in accordance to Level 1 and 2 plant conditions.

The effects of ruptures are:

- missiles production
- lashing effect
- reaction forces on the circuit
- forces developed by fluid jets
- room pressurization
- circuit depressurization wave

Missile production criteria have been analyzed in paragraph 2.7.

In the analysis of consequences of the lashing effect, the circumferential rupture of piping with a diameter equal or greater than the damaged piping is excluded, while the longitudinal crack will be taken into consideration if the piping thickness is very small; ruptures will always be taken into consideration for piping with a diameter smaller than the damaged piping.

Jet forces will be neglected for distances greater than 10 times the damaged piping diameter.

In the case of longitudinal rupture, the reaction forces and the jet forces will be evaluated on the basis of an elliptical rupture with major semiaxes equal to the piping diameter and area equal to the piping flow area.

Protections taken into consideration are: separation, barriers, shielding and piping constraints.

Rupture outside of the reactor building

The design criterion applied is to physically separate the SC1 and SC2 components and structures, in order to avoid that any piping rupture may damage other components and piping.

Leak Before Break methodology application

The Leak Before Break (LBB) methodology is aimed at assuring that any large rupture in piping and components is preceded by a leak of the contained fluid which is sufficient to be detected by a monitoring system. This allows both to neglect the dynamic effects connected to a sudden rupture at the design stage, and to exclude a sudden loss of the system functionality, allowing the system depressurization in safe conditions.

In the MARS plant, the LBB methodology is applied in-depth, following two different approaches:

- i) the whole primary coolant boundary and the connections of the auxiliary systems to the primary coolant boundary are enclosed in the pressurized containment, so as to avoid any meaningful pressure difference between the

- internal and the external side of piping and components; which is the cause for sudden increases of break size;
- ii) piping and components of the auxiliary systems not enclosed in the pressurized containment are designed and verified to assure the absence of any sudden rupture.

LBB methodology for primary coolant boundary

The virtual absence of pressure difference between the internal and the external side of piping and components of the primary coolant boundary makes a fast growth of any failure (as cracks), should it be present (or should it have been borne for any reason) physically impossible. In any case, an integrity defect (which appears unrealistic for the above said reasons) would cause a small leakage (thanks to the small pressure difference across the pressure boundary assured by the control system) of primary coolant into the pressurized containment; this leakage would be detected by the continuous monitoring of the activity of the pressurized containment (CPP) water. The monitoring system will be able to detect a loss of primary coolant higher than 25 liters.

LBB methodology for piping and components not enclosed in the pressurized containment (CPP)

The application of the LBB methodology in such a case requires that by design any sudden rupture be excluded. The following actions are foreseen, according to the US-NRC methodology.

- The probability of fatigue rupture, erosion, intergranular stress corrosion and water hammer rupture must be verified.
- In the MARS plant the operational conditions (pressure and temperature) allow to exclude ruptures due to creep or high temperature fatigue.
- Rupture due to fatigue at a low number of cycles shows an extremely low probability, since this rupture mode has been, and will be, taken into consideration by design.
- Erosion and intergranular stress corrosion are not a failure mode in the MARS plant both because they are taken into account during the design phase and in the operation phase (overthickness, water characteristics, material choice) and because of the operational conditions which make them definitely improbable.
- Water hammer effects will be taken into consideration during the following design phases.
- The most conservative values of material properties must be assumed.
- The stress analysis of piping and components must be executed.
- It will be performed using the design loads and the safety shutdown earthquake (SSE) loads acting simultaneously.
- The most critical zones will be analyzed for the subsequent crack analyses.

- The analysis of stability of a reference crack involving the whole thickness of the piping will be executed.
- The reference crack has dimensions allowing a leakage flow (during Level 1 conditions) ten times higher than the minimum flow detectable by instrumentation.
- Two load conditions will be analyzed:
 - Level 1 conditions plus SSE
 - Level 1 conditions multiplied by 1.41
- The fatigue analysis of a reference crack not involving the whole thickness of the piping will be executed. A construction defect in the critical zones will be hypothesized and its propagation will be studied.

1.13 Criteria for protection against external events due to human actions

In addition to the reference impact (or missile) previously analyzed, a plane pressure wave with the following pressure-time diagram will be taken in consideration:

time (s)	0	0.1	0.2	1.0	>1
pressure (bar)	0	0.45	0.3	0.3	0

1.14 Criteria for protection against seismic events

For reference purposes, three reference sites are taken into consideration at this stage of plant design: "rock" site, "hard" site, and «soft" site. The selection of specific site characteristics will follow the identification of the site hosting a new plant.

Two design earthquakes are considered for each site:

- Safe Shutdown Earthquake (SSE) - that is the maximum earthquake that may occur in such a site (whose frequency is between $1 \cdot 10^{-3}$ and $1 \cdot 10^{-4}$ events/year);
- Operating Base Earthquake (OBE) - that is the maximum earthquake expected during the plant life (whose frequency is of the order of magnitude of $1 \cdot 10^{-2}$ events/year).

The SSE, for the three reference sites, is assumed to cause a horizontal acceleration of the soil free surface equal to 0.24 g (IX level of Mercalli scale, according to the Trinfunac-Brady correlation).

The vertical acceleration due to the SSE is assumed equal to 0.24 g for hard and rock sites, 0.16 g for the soft site.

The intensities of the OBE are assumed equal to one half of the SSE ones.

The response spectra for hard and rock sites are the same as in NRC RG 1.60, while they have been adapted to site characteristics for the soft site.

The dumping coefficient for components and structures are according to NRC RG 1.61 and ASME Boiler and Pressure Vessel Code Case N-411, while for structures they are according to ASME Boiler and Pressure Vessel Code, section III Div. 1 and ASME/ANSI B31.1.

The soil dumping characteristics will be evaluated at the phase of detailed design by means of geotechnical analyses.

Structures and components classified as SC1 will be analyzed using dynamic analyses, while piping with diameter lower than 2", wire ways, HVAC conduits, instrumentation conduits, will be analyzed using static analyses.

Experimental analyses are also foreseen.

All SC1 components shall preserve their operability during the OBE and their functionality during the SSE.

SC2 components and structures shall be analyzed for SSE and OBE loads using static or dynamic analyses.

All SC2 components shall preserve their operability during the OBE and their integrity (but neither operability nor functionality) during the SSE.

1.15 Design loads for SC1 structures

The reactor building, the control building, the radioactive waste treatment building, and the fuel building are classified as SC1.

Such buildings are manufactured using reinforced concrete, according to ACI 318 and ACI 349 codes; for steel liners, AISC N690, ASME Boiler and Pressure Vessel Code, section III Div. 1 codes will be used.

The following loads will be considered:

- constant loads
- operational loads
- wind
- tornado
- snow
- thermal gradients
- internal pressure
- piping break
- SSE
- OBE
- missiles
- pressure wave
- soil pressure

1.16 Criteria for design of mechanical systems and components

The following requirements will be assumed as input during the detailed design phase, for the various plant conditions.

- Level 1
 - During Level 1 plant conditions, the detailed design of all systems and components shall be such that protection systems intervention will not have to be required to maintain process parameters within the ranges specified in Technical Specifications;
 - No Level 1 condition shall engender a more severe condition if no other accident takes place.
- Level 2
 - During Level 2 plant conditions the plant shall be able to remain or to return to full power operation with all protection systems available;
 - No Level 2 condition shall engender a more severe condition if no other accident takes place.
- Level 3
 - During all Level 3 plant conditions all safety systems necessary to mitigate accident consequences shall maintain their functionality;
 - No Level 3 condition shall engender a more severe condition if no other accident takes place.
- Level 4
 - During all Level 4 plant conditions all safety systems necessary to mitigate the accident consequences shall maintain their functionality.
 - No Level 4 condition shall engender a more severe condition if no other accident takes place.
- Additional Level
 - During all Additional Level plant conditions, all safety systems necessary to mitigate the accident consequences will maintain their functionality.
 - No Additional Level condition shall engender a more severe condition if no other accident takes place.
- Severe Accident Level
 - During Severe Accident Level, all efforts aimed at maintaining the functionality of systems allowing to contain and/or to cool relocated corium with a reasonable degree of success must be done.

1.17 Load conditions for components and systems relevant to safety

The following load conditions will be adopted for the design of components and systems relevant to safety:

Level	Load condition
1	W+P
2	W+P+OBE
3	W+P+J
4	W+P+J+SSE
Additional Level	W+P+J+SSE

where:

- W : weight, constraint forces, dynamic forces, forces due to handling during the event;
P : pressure loads (including reaction loads);
J : jet forces;
OBE : operating base earthquake forces
SSE : safe shutdown earthquake forces.

1.18 Criteria for seismic qualification of mechanical and electric systems

The seismic qualification for SC1 and SC2 mechanical and electric systems will be performed through experimental campaigns, dynamic or static analyses.

Static analyses will be adopted if the natural frequency is higher than the forcing frequency or if the structure may be schematized as a frame.

Dynamic analyses will be adopted for large systems for which experimental campaigns are difficult or if only the structural integrity (and not the operability) must be demonstrated.

Whenever possible, both analytical and experimental data will be used for qualification.

1.19 Criteria for environmental qualification of mechanical and electric systems

All systems and components relevant to safety, the SC2 components and the instrumentation for post-accident monitoring will be qualified according to the anticipated accidental conditions.

Both analytical and experimental methods will be allowed, as well as operational expertise.

The tests will examine the effects of thermal and mechanical aging, vibrations, environmental conditions, radiation.

2 Relevant design choices coherent with the MARS design principles, targets and criteria

2.1 *Emergency core cooling relying on physical laws only; irrelevance of human factor to plant safety*

The MARS plant is equipped with a new type of emergency core cooling system (ECCS called Safety Core Cooling System, SCCS) which:

- is fully passive;
- is basically static [only one non-static component is present, an easy-to operate check valve, 200% + 200% redundant (two technological solutions adopted on two independent trains)];
- relies on density gradients of fluids for their flow;
- relies on external air as heat sink (infinite autonomy);
- is completely testable during plant operation.

The operation principle is shown in Fig. 1. During normal plant operation, two redundant check valves prevent primary coolant from flowing through the primary side of the innovative SCCS, for each train. In accidental conditions, the reduction of coolant flow through the core will cause coolant flowing through the primary side of the SCCS (in the two trains). Heat will be transferred to the atmosphere through a cascade of completely static circuits.

The possibility of guaranteeing the residual heat removal in emergency conditions by means of a completely passive (and mainly static) system greatly increases the plant inherent-safety degree, allowing the selection of a very simple (and therefore extremely reliable) circuitry for the whole boundary containing the primary coolant.

The "new" emergency decay heat removal system (SCCS) is based on natural circulation of fluids. Pumps, motors, other active electric components and emergency diesel generators with annexed auxiliaries are completely avoided. The availability of an adequate heat sink with an infinite capacity (external air) guarantees a theoretically never ending cooling, without the need for external water feed requirements.

The limitation of components which are in contact with potentially activated fluids greatly reduces yearly doses to personnel due to maintenance.

Such a choice considerably influenced the entire MARS plant design and layout selection; the plant is extremely simplified compared to "traditional" plants; the only drawback is the limitation of thermal power of the core, which is limited to a maximum value which realistically is in the range of about 700-1000 MWth.

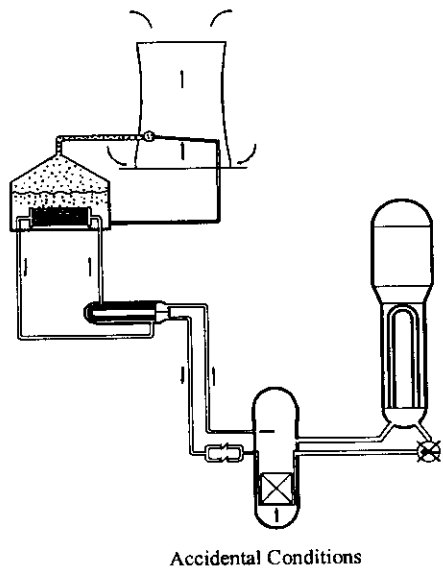
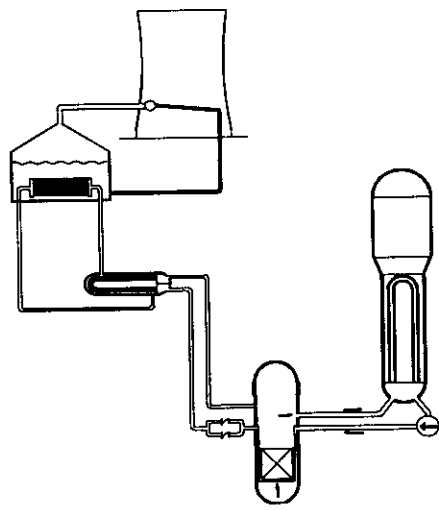

Figure 1 - Operation principle of the MARS emergency core cooling system

2.2 A-priori elimination of main initiating events and/or causes of nuclear accidents

A drastic limitation of accidental scenarios typical of traditional nuclear plants may be achieved only through the implementation of the **in-depth prevention criterion applied to coolant losses** which are the main cause of radioactive releases from the core.

This has been accomplished through the following design choices:

- enclosure of the whole primary-coolant boundary in a pressurized containment filled with low-enthalpy water (CPP) (this eliminates primary stresses on the primary coolant pressure boundary, preventing wall ruptures and preventing crack growth; it adds a containment barrier to the release of radioactive products into the reactor building atmosphere);
- elimination of physical interfaces between the core coolant within the primary circuit and the external environment (only one pump is used, canned-type rotor; the flow to/from the Chemical and Volume Control System (CVCS) is limited to very short periods and is guaranteed through two small-size connection lines, equipped with eight check valves, of different type);
- reduction of the maximum core coolant temperature well below the value of 290 °C, verified as the threshold value for stress corrosion phenomena in tube bundles of Alloy 600, which are the cause of steam generator tube ruptures.

With the exclusion of accidents due to fuel element handling, the majority of potential nuclear accidents in traditional LWR plants is originated by the coincidence of a high pressure and a high specific internal energy in the core cooling fluid. In the worst accidents (LOCAs, control rod ejection, etc.), the origin of deterioration of core cooling is a consequence of ruptures in the primary coolant pressure boundary. **One of the main goals considered in the development of the MARS plant design was the removal of possible causes of rupture of the primary coolant pressure boundary, and therefore also the removal of causes of rupture of the emergency cooling system pressurized boundary.** This has been achieved through the adoption of a **null pressure difference between the primary coolant and the environment housing the primary coolant boundary itself.**

This solution allows the operation of the primary coolant system pressure boundary (**including the reactor vessel itself**) in the absence of primary stresses (ASME Boiler and Pressure Vessel Code, section III).

Should, the external pressurized containment (CPP) break as a consequence of catastrophic events, the loss flow of the low-enthalpy containment fluid would be very small, depending on the volume of a pressurized gas cushion. This loss would not be dangerous for the primary coolant boundary and in particular for the core and could permit a safe core shutdown in an intact pressure boundary (the primary coolant boundary).

On the other hand, anticipated losses from the primary cooling system into the pressurized external containment (CPP) would be extremely improbable, involving

very limited amounts of core coolant, and with no consequences, owing to the extremely low flow-rates and loss amounts.

Obviously, the design of the low-enthalpy-water-filled pressurized containment (CPP) has to demonstrate the non-applicability of the common mode of failure with the primary coolant boundary. Loss Of Coolant Accidents (LOCAs) are prevented (their theoretical probability is limited to values lower than $1 \cdot 10^{-9}$); Control Rod Ejection accidents (the worst accidents in PWR's owing to the fast fuel enthalpy increase) are also prevented for the same reason.

The enclosure of the primary-coolant boundary in the low-enthalpy-water-filled pressurized containment **allows the possibility of using flanged components for the primary coolant boundary**. Each component, including the reactor vessel and the steam generator, may be easily substituted or repaired, with obvious benefits for plant availability, maintenance costs, life extension, easy and rapid decommissioning.

Flanging is used to transmit the loads, while tightness is assured through special welded gaskets in the joining sections.

Finally, the reduced value selected for the coolant temperature in the primary coolant (ranging between 214 °C and 254 °C), ensures elimination of steam generator tube ruptures, even if the design of the plant has taken into account such accident among design basis accidents. Furthermore, in order to prevent the possibility of a steam generator tube rupture becoming a small-break-loss-of-coolant-accident, the shell of the steam generator has been designed to withstand the primary coolant pressure, as well as the steam line, up to (including) two on/off valves.

2.3 Elimination of scram failure accidents (including ATWS)

Two, completely independent, scram systems are foreseen in the MARS plant design:

- the first system is a **traditional system** including clusters of neutron absorbing control rods hung through electromagnetic jacks and acting, (under electric signals), through the introduction of the clusters into the core by gravity;
- the **second system** is an **innovative system** (called ATSS: Additional, Temperature-actuated Scram System) , including clusters of absorbing control rods, which are sustained outside of the core through the action of mechanical hooks. Special two-metal bars placed within fuel assemblies cause the release of the hooks and the introduction of the control rod clusters into the core as a consequence of undesired increase of coolant temperature.

As all transients in the MARS plant are slow transients, if the first traditional-type scram system fails, the second scram system will intervene, since its operation is based on physical laws and on passive components only.

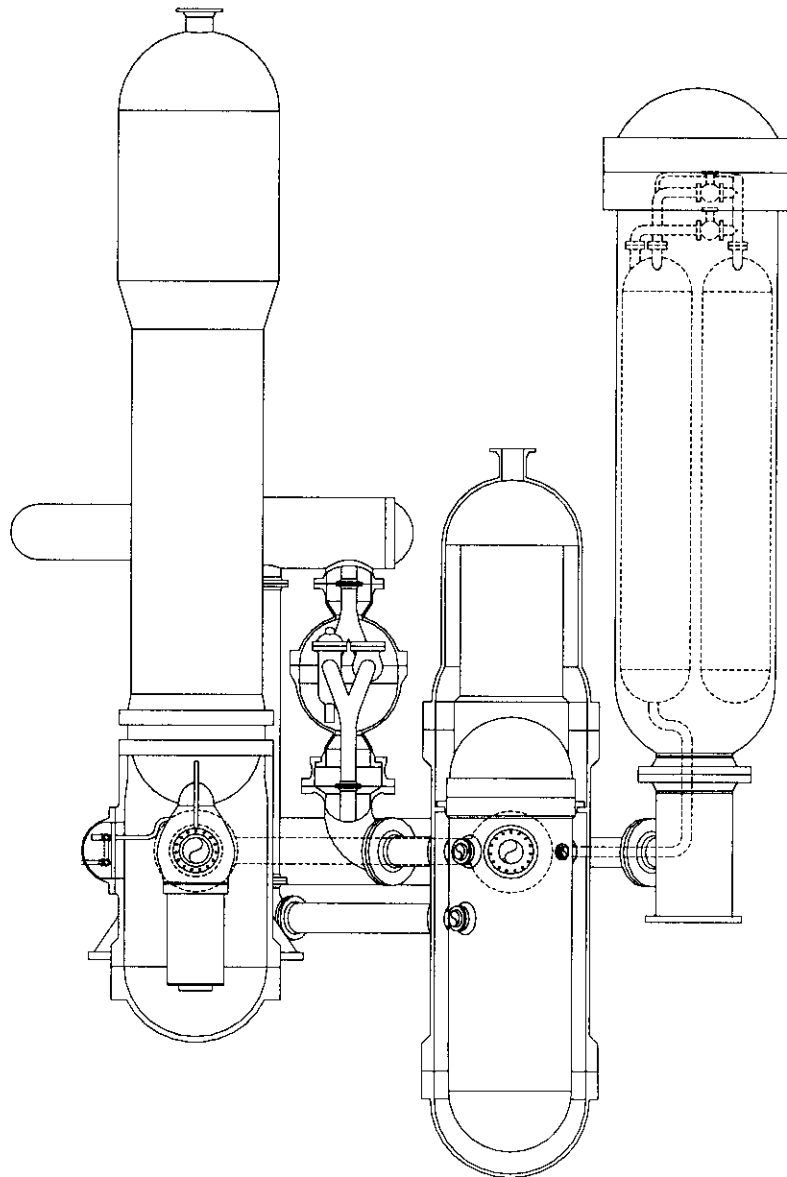

Figure 2 - Scheme of the pressurized containment for primary loop protection (CPP)

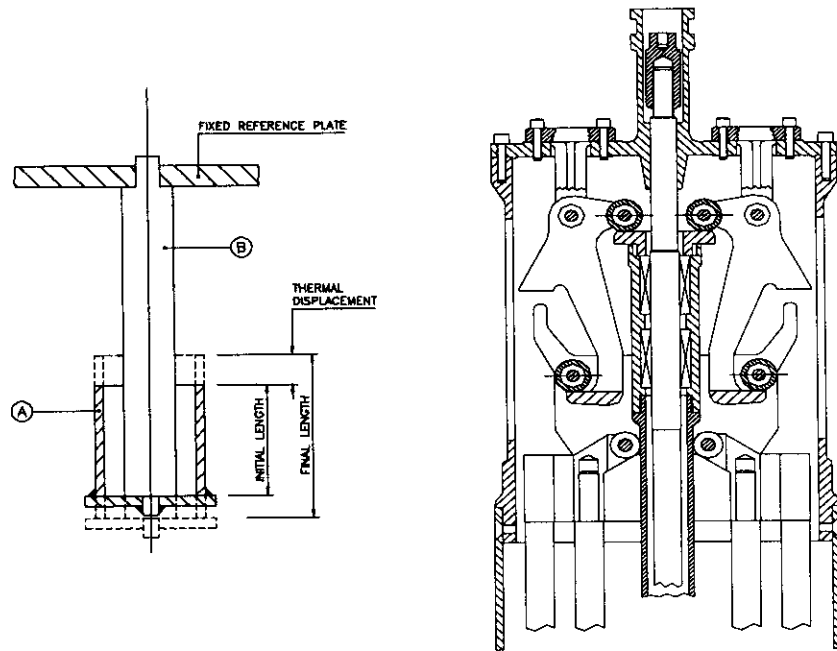

Figure 3 - Operation scheme and self-releasing head of ATSS

2.4 Removal of core damage causes, potentially leading to severe accidents and radioactive releases

This is achieved through the combination of the following four choices:

- the nearly-complete enclosure of the primary-coolant boundary in the low-enthalpy-water-filled, pressurized containment (CPP),
- the hydraulic isolation of the primary coolant boundary (the only physical interface is the intermittent connection with the primary loop Volumetric Control System (VCS), through small-diameter lines, equipped with 8 check valves),
- the special design of the steam generator, with shell, steam line and two valves on the steam line itself designed to withstand the primary coolant design pressure,

- the elimination of possible mechanical failures of the primary coolant pressure boundary thanks to its enclosure within the low-enthalpy-water-filled pressurized containment (CPP).

The MARS nuclear plant is designed to prevent loss of coolant accidents: it is expected to be able to guarantee a never-ending core coolability. Furthermore, the elimination of fast fuel enthalpy transients (elimination of control rod ejection accidents and the elimination of fast primary coolant dilution accidents) and the protection against scram failures (provision of the additional, inherently-safe core scram system) eliminate transient situations potentially leading to core geometry modifications.

If the core geometry is maintained and the core is cooled, no radioactive release from the fuel is expected.

2.5 Capability of the plant to "easily" manage severe accidents

In spite of the vanishing probability of fuel melting as a consequence of the application of the above listed criteria, the design of the MARS plant has nonetheless been developed taking into account the possibility of fuel melting: it has been developed according to the criterion of an "easy" management of even such extreme events, to assure radiological protection to personnel and population.

The consequent design choices include:

- the elimination of any type of penetration through the core vessel lower head
- the utilization of the cold water filling the low-enthalpy-water pressurized containment (CPP) to remove corium decay heat
- the design of the lower head of the reactor vessel (thickness; absence of external insulation; special internal devices to eliminate water convective flow in normal conditions) so as to allow the complete removal of decay heat from corium through conduction within the lower head and boiling on the external surface of the lower head
- the utilization of the reactor building for condensation of steam on the internal surfaces, to finally transfer the decay heat of radioactive products to external air (the reactor building is a single-wall containment).

2.6 Higher safety margins during normal operation

They are achieved through the following choices:

- higher DNBR values (given lower core power density and lower operation temperatures);
- lower boron concentration in the primary coolant and drastic reduction of accidental boron dilution consequences.

2.7 *Initiating events limitation*

In addition to the huge reduction in the number of safety-relevant components with respect to traditional plants and to the extensive utilization of passivity and of "inherent" safety features, the limitation of events that could potentially initiate accidental sequences is also obtained through:

- a high standard of protection against external events, thanks to the adoption of severe criteria against external events;
- an extremely high standard of protection against fire accidents achieved through a drastic reduction in the number of electric motors and diesel generators and through the choice, for each of the few electric motors connected to primary-coolant-facing-components, of an inert-gas operation.

2.8 *Reduced vulnerability (protection against sabotage)*

This is achieved through:

- reduction of number and sophistication of components relevant to safety
- presence of only a few components relevant to safety outside the reactor building, and only of the passive type
- drastic simplification of the emergency core cooling system, allowing all components and systems facing primary coolant to be housed in the small-size reactor building.

2.9 *Lower radiation doses to personnel*

This is achieved through the following choices:

- simple circuitry
- nuclear, thermal and mechanical design of the reactor core so as to cause a source term of radioactive products released by fuel matrix to the gap during normal operation, reduced by a factor higher than 50 with respect to traditional PWRs (obviously, with a same power level);
- thermal and mechanical design of the reactor core so as to cause a radioactive products release rate by fuel cladding during normal operation reduced by a factor higher than 5 with respect to traditional PWRs (with a same gaseous inventory of radioactive products in the gap);
- thermal and mechanical design of the RCS so as to cause a source term due to activated products in the coolant during normal operation reduced by a factor higher than 50 with respect of traditional PWRs (with a same power level);
- use of cobalt in the RCS system is abolished;

- nuclear, thermal and mechanical design of the reactor core such as to allow a primary coolant stream to be handled by the waste treatment system 30% lower than the corresponding value for traditional PWRs with a same thermal power;
- very few maintainable components physically interfacing with potentially activated reactor core coolant;
- primary system enclosed in the water-filled containment (external radiation shielding + active components accessible through shielding water);
- minimization of primary coolant clean-up requirements through the reduced boron concentration in the primary coolant and the optional adoption of AISI 304 fuel rod cladding (huge simplification of the primary coolant auxiliary systems);
- complete accessibility of the reactor building;
- possibility of complete disassembling of all primary-coolant components, allowing a choice between substitution and repair;
- probability of steam generator tube rupture reduced practically to zero (maximum primary coolant temperature: 254 °C);

2.10 Reduced production of solid radioactive wastes

This is achieved through the following design choices:

- plant simplification so as to cause an amount of active resins and filter cartridges present in the plant reduced by a factor higher than 5 with respect to traditional PWRs (with a same power level);
- thermal-hydraulic design of the RCS and of the auxiliary circuits such as to cause a life extension of existing resins and filter cartridges higher than 100%;
- very few maintainable components physically interfacing with potentially active liquids, allowing the reduction of Dry Active Wastes (DAW) by a factor higher than 10 with respect to traditional PWRs (with a same power level).

These innovative features allow to reduce the production of solid radioactive wastes to 5 m³/year only, if traditional conditioning methods (such as low-pressure compacting and neutralization) are used (against more than 20 m³/year of solid radioactive wastes produced in traditional PWRs with the same power level); using advanced conditioning methods (such as high-pressure compacting and incineration) the solid wastes produced in the 600 MWth MARS nuclear plant would decrease to 1 through 2 m³/year only (5÷10 220 l barrels).

2.11 Reduced and certain costs

These are achieved through the design choices listed below.

Construction Phase

- A huge plant simplification has been achieved, thanks to:
 - a) drastic ECCS simplification
 - b) easy to manufacture, single-containment reactor building
 - c) drastic reduction of "Safety Grade" systems and components
 - d) drastic simplification of nuclear waste treatment systems and of primary coolant auxiliary systems
- A high possibility exists for primary coolant components preassembling, given the lower operating pressure and the use of "small size", flanged components for the fluid systems (optional)
- A very high possibility exists for auxiliary system preassembling, given the complete accessibility of the reactor building (geometrical optimization, no constraints imposed by the necessity of withstanding LOCA pressurization)
- A lower unit cost is possible for main components, given the lower pressure, easier construction technologies and easier shop machine depreciation (certainty of costs of well proven technology components)
- The maximization of in-shop activities is achieved with respect to in-site ones (including construction, tests, etc.)
- Minor interfaces exist during construction, particularly between civil and electro-mechanical works (one of the main causes of unexpected delays)
- The test phases are drastically simplified both in-shop and in-field
- Depreciation time for the plant may be substantially extended (plant life is quite longer than component life, due to replaceability of all components in the plant).

Operation and maintenance phase

- Very high load factors are possible (>90%)
- Long in-core permanence of fuel is possible
- Minor maintenance requirements exist (few components; not activated)
- Easy testing is possible (few components; test oriented design)
- The reactor building is easily accessible
- Even major components are replaceable, if required

Decommissioning

The MARS design is truly decommissioning-oriented for all components, fluid systems, structures, and buildings, given the drastic limitation of activated components, their easy disassembling, and the overall plant design substantially typical of a mechanical plant.

2.12 Enterprise risk reduction

This is achieved through the adoption of: small/medium size of the plant; proven technology; few and “small” components; extended pre-assembling of all fluid systems.

2.13 Extended industrial applications

Extended industrial applications are possible for the MARS nuclear plant because of:

- the extremely high safety standard, so as to allow plant siting near inhabited areas
- the selected plant design and layout, with remarkable characteristics of modularity
- standardization of components and systems

3 Notes on some consequences of the design criteria selected for the MARS plant

In traditional LWR plants, the plant complexity, the multitude of possible accidental sequences, and the possible operator errors during accident evolutions, make both the design of the plant safeguards and the demonstration of the real capability of the systems to control any accident evolution complex, especially in a medium-term perspective and if human errors are hypothesized.

In the MARS plant, thanks to the simplicity and the safety design criteria of the primary coolant circuitry, the number of hypothesizable accidental evolutions is greatly reduced, the role of the human error in the accident evolution is virtually eliminated, and the safety analysis itself results significantly simpler and totally reliable.

In the MARS plant, the synthesis of the two aspects that mostly enforce the safety characteristics of PWRs and BWRs has been possible: the physical separation between the primary cooling system (inside the low-enthalpy water-filled containment, CPP) and the user fluid system (PWR), and the availability of relevant reservoirs of low-enthalpy water inside the reactor building (BWR).

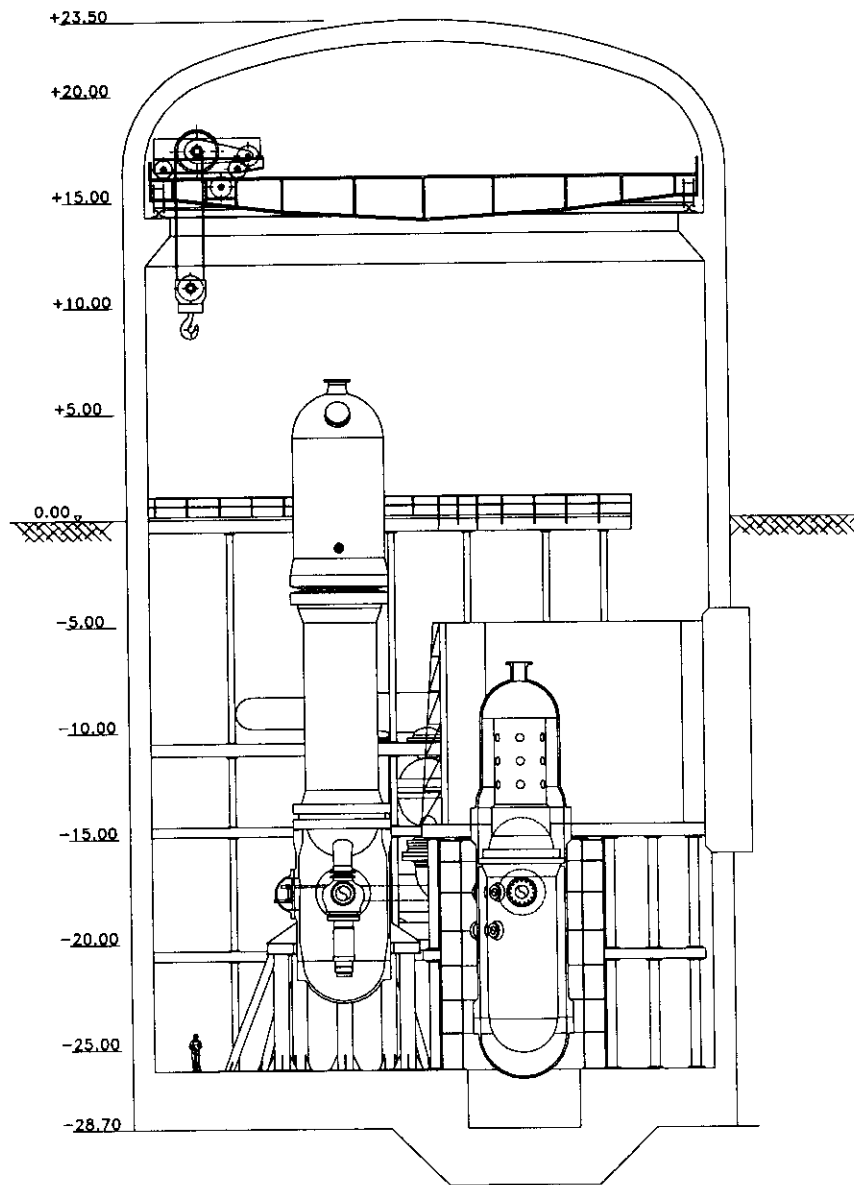

Figure 4 - Reactor building section

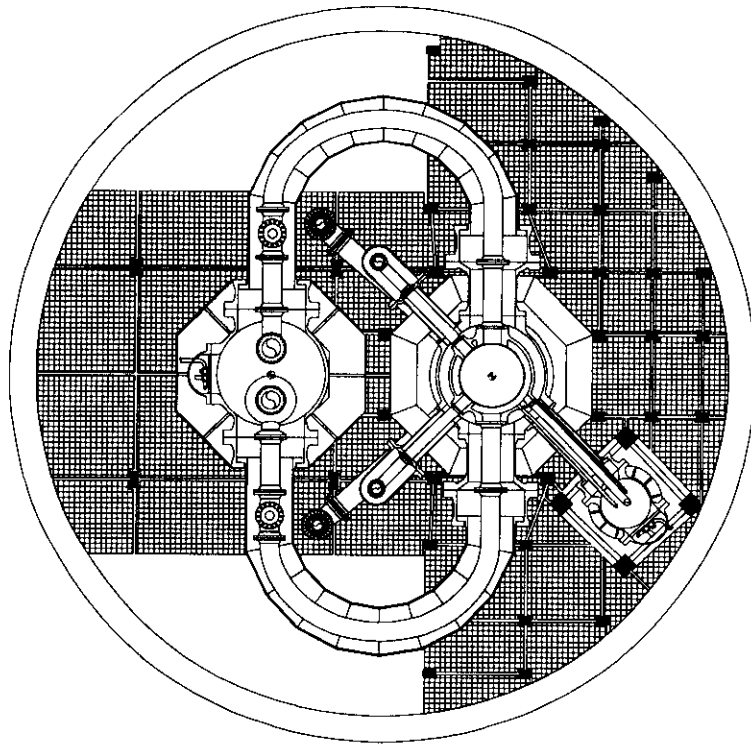

Figure 5 - Reactor building plan at primary loop nozzles elevation

4 Evaluation of the total production cost of electric energy

With reference to the study [1], to which the reader is addressed for a detailed description of systems, components, buildings and related costs, a power station with three MARS modules has been considered.

4.1 *Description of plants and of accessory works for the reference power station*

In Figure 6 a general scheme of the reference power station is reported.

Three reactor buildings are evident, with the auxiliary-systems buildings, within which the following plant systems are hosted:

- Primary coolant chemical and volumetric control system
- Residual heat removal system
- Auxiliary systems of the pressurized containment for the primary system protection (CPP) (chemical and volumetric control system; cooling system)
- Radioactive waste treatment system
- Ionic exchange resins treatment system
- Boron treatment system.

The following main buildings are also shown:

- Fuel building
- Radioactive waste storage building
- Turbine building.

These buildings serve the three production units, so as the following service buildings:

- Offices and guard-house
- Medical center
- Workshop
- Big component maintenance building
- Diesel building.

The whole nuclear plant, including the nuclear steam supply system, the balance of plant, and the various, both nuclear and non nuclear, auxiliary systems as well as all civil works have been divided into a disaggregation level such as to allow the application of unit cost easily verifiable through direct experience.

This procedure has requested the design of all works, both electromechanical and civil, at a detail level such as to allow the assessment of detailed technical specifications (regarding performance, dimensions and materials) for the main components (for them, an individual economic analysis has been performed) as well as the functional technical specifications for the various minor auxiliary systems. For the civil works it has been sufficient the development of a preliminary design taking into account only the functional and safety requirements: the economic analysis of the works has been based on the analysis of the safety classification of each cost item, and to the volume and/or amount of construction material employed. Obviously and conservatively, suitable margins have been incorporated for what regards the functional specifications, but also and mainly for what regards the safety characteristics.

One of the characteristic of the MARS is the drastic reduction of the concrete volumes utilized for the plant construction; in Table 1 the list of the concrete volumes in the 450 MWe plant is reported, taking into account different "filling levels of reinforcement iron"

Table 1 – Concrete volume in a 450MWe MARS plant

Concrete type	Volume (m³)
"High steel density"	13,140
"Medium steel density"	28,100
"Low steel density"	32,250
Total	73,490

The utilized concrete corresponds to about 160 m³ for each installed MWe, while in traditional PWRs about 280 m³ of concrete are utilized as average value for each installed MWe.

The costs indicated in the following refer to a construction in a country with the characteristics of Italy at the date of January 1, 1998. They are expressed in US\$ (1998) and in EURO (an exchange rate of 1.1 US\$/EURO has been utilized).

The very detailed cost analysis performed [1] has produced, as result, the identification of a provisional cost for each system and sub-system of the power station. The whole power station has been divided into 36 macrosystems; the cost for each macrosystem is shown in Table 2.

The cost items listed in Table 2 are, obviously, the result of the detailed cost analysis of the components belonging to the specific system or sub-system. Just as an example, in Table 3 the main cost items of the reactor coolant system are shown.

The total direct investment cost for the 450 MWe MARS power station, including a 10% overestimation to take into account contingencies during construction, is **745,895,000 US\$ (678,083,000 EURO)**, corresponding to a unit direct cost of **1657 US\$/kWe (1507 EURO/kWe)**.

The indirect costs have been assessed very simply as a percentage of the direct costs, utilizing official data published by the Department of Energy (DOE) of the Government of the United States of America.

The average incidence of indirect costs evaluated by the USA DOE with respect to direct costs, for nuclear plants, is 18% [4,5]. The items of indirect costs are shown in Table 4.

It is to be remarked that some of the costs shown in the Table are, in the case of a further cost analysis for the reference MARS power station, susceptible of a drastic reduction: the limited dimension of mechanical components in general, the very low volumes of civil works, the total prefabrication of components assumed among the main design criteria for this type of plant (with the consequences that it brings in terms of simplification of activities in the site and of the white tests and start-up tests), are all causes for this reduction. Nevertheless, in the view of a conservative cost assessment, the percentages proposed by the USA DOE and verified for the huge nuclear installation park built according to traditional criteria has been adopted also for the MARS station.

The total indirect construction cost for a 450 MWe power station equipped with three 150 MWe MARS reactors has been assessed, therefore, as **134,261,000 US\$ (122,055,000 EURO)**, corresponding to **298 US\$/kWe (271 EURO/kWe)** installed.

- | | | | |
|----------|---------------------|----------|-----------------------------------|
| 1-2-3 | Reactor building | 22-23-24 | Dressing and decontamination |
| 4 | Turbine building | 25 | Backup diesel system |
| 5 | Fuel way | 26 | Workshop for activated components |
| 6 | Spent fuel building | 27 | Chimney |
| 7 | Laboratories | 28 | Offices |
| 9-10-11 | Auxiliary building | 29 | Workshop |
| 12-13-14 | Control room | 30 | Medical center |
| 15 | Power station | 31 | Wastes storage |
| 16-17-18 | Motor power center | 32 | Big components workshop |
| 19-20-21 | Wastes building | | |

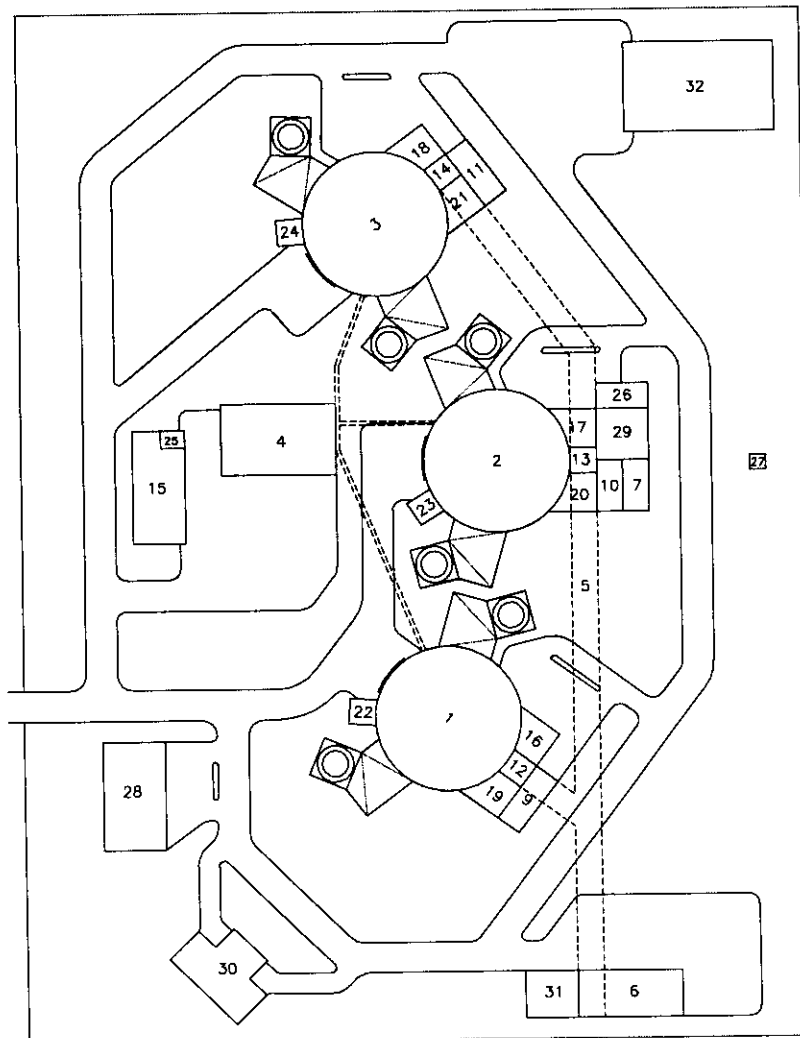

Figure 6 - Plan of a 450 MWe plant (3 MARS units)

Table 2 - Cost of a 450 MWe power station (3 MARS units)

System	Cost (,000 US\$)	Cost (,000 EURO)
Buildings	61,774	56,158
HVAC systems	10,375	9,433
Closed circuit water cooling system and main condenser	36,743	33,402
Control rod systems	8,230	7,482
Fuel handling and storage system	7,982	7,256
Reactor coolant system (RCS)	112,952	102,684
Pressurized containment for primary loop protection (CPP)	59,609	54,192
Safety core cooling system (SCCS)	11,894	10,813
Main RCS auxiliaries	9,245	8,404
CPP auxiliaries	4,327	3,933
Reactor auxiliaries	8,900	8,091
Containment building safeguards	836	760
Radwaste system	2,388	2,172
Turbine	99,282	90,257
Condensate system	27,738	25,215
Feedwater system	12,950	11,773
Main steam system	12,453	11,320
Electric power station	48,174	43,794
Protection systems	1,766	1,605
Control systems	8,672	7,883
Plant supervising system	9,199	8,362
Environmental monitoring system	470	427
Plant monitoring system	1,842	1,674
Electric boards and panels	6,458	5,870
Neutron monitoring system	2,050	1,864
Demineralized water system	323	294
Auxiliary steam system	257	234
Instrumentation air system	800	727
BOP fire protection system	123	112
Elevators and lighting system	6,260	5,691
Common services and common buildings	12,846	11,678
Condenser cooling water system	43,615	39,650
Minor RCS auxiliaries	14,321	13,019
Turbo-alternator lubricating system	146	133
Plant electrical system	18,227	16,569
Other plant auxiliaries	14,859	13,508
Total	678,086	616,439

Table 3 - Detail of reactor coolant system (RCS) costs

System or component	Cost (,000 US\$)	Cost (,000 EURO)
Core vessels	7,465	6,786
Core vessels integrated heads enclosure	106	96
Core vessel internals	4,301	3,910
Control rod driving systems	21,977	19,979
Steam generators	55,735	50,668
Steam generator isolation systems	3,572	3,247
Pressurizers	2,249	2,045
Primary loop interception valves	706	642
Primary pumps	12,618	11,471
Primary loop supports	1,303	1,185
Primary loop piping	2,202	2,002
Other components	718	653
Total	112,952	102,684

The total construction cost, calculated on the basis of the analysis of all disaggregated direct costs and inclusive of contingencies during construction and of indirect costs, is of **880,156,000 US\$ (800,138,000 EURO)**, corresponding to **1956 US\$/kWe (1778 EURO/kWe)** installed.

This cost does not take into account financial costs.

The operation cost has been assessed analyzing separately the following cost categories:

- fixed operation costs, including the costs for operation and maintenance personnel and other costs independent from the production level (kWh produced in the year)
- variable operation costs, including the costs for spare parts and consumables, dependent on the level of utilization of machinery (excluding nuclear fuel)
- costs of nuclear fuel.

The personnel costs have been assessed hypothesizing a personnel requirement (with the heavy redundancies depending on the labor laws applied in Italy and, in particular, presently applied in the electric generation field) of 183 units, for which an average yearly cost referred to average market conditions applicable in Italy of **10,980,000 US\$ (9,982,000 EURO)** may be assumed.

The fixed operating costs, not including the personnel cost, have been assessed as **5,000,000 US\$/year (4,545,000 EURO/year)**.

The total fixed costs for operation are, therefore, **15,980,000 US\$/year (14,527,273 EURO/year)**, corresponding to **35.5 US\$/kWe*year (31.7 EURO/kWe*year)**.

Table 4 – Splitting of indirect costs during construction (source DOE)

Cost item	Including	Percentage of direct costs
Additional construction costs	Cost of equipment removed or dismantled after the construction	10%
	Leasing of equipment	
	Personnel training	
	Managing and storage of materials	
	Materials and equipment tests	
	Operation and maintenance of the equipment	
	Site cleaning	
Design and construction management (In the hypothesis that the plant belongs to a standard series and therefore the design costs and licensing costs are only those specific for the site)	Design costs	3%
	Licensing costs	
	Administrative management costs	
Other costs	Royalties	5%
	Insurance	
	Start-up tests	

The variable operation costs, in case of operation of the plant for a base service (rated power without operation in load-following, with a yearly production of 3,942,000,000 kWh), have been evaluated as 4,000,000 US\$ (3,636,000 EURO), corresponding to 0.001 US\$/kWh (0.00092 EURO/kWh).

The fuel cost has been evaluated taking into account the low enrichment required for the MARS reactor (2.8% in U²³⁵) and of the standard characteristics (as for dimensions and materials) of the fuel, of cladding, of fuel assembly sub-components (the low power density selected for the core has to be reminded, which allows, in addition to quite high safety margins, also a very long irradiation period. With a scheme of core fuel loading of one third of core, it is possible to obtain full power irradiation cycles of one year and a half, with one month dedicated to the operation of refueling, and a number of irradiation cycles for the various elements

of fuel ranging between three, in the case of elements with the highest radial peaking factors, and four).

A full core for each of the three reactors of the reference power station has a cost that may be assumed as ranging between some **35,000,000** and some **46,000,000 US\$ (31,818,000 ÷ 41,818,000 EURO)**. This core is able to produce more than 6,200,000,000 kWh, but conservatively we have assumed, for each equilibrium core, a production of 5,913,000,000 kWh (corresponding to the hypothesis that only three irradiation cycles are applicable for all the elements). In this very conservative hypothesis, the specific cost of the electric energy produced, depending on the nuclear fuel only, ranges between **0.0059** and **0.0078 US\$/kWh (0.0054 ÷ 0.0071 EURO/kWh)**. Just as a reference and taking into account all the cost items that contribute to the definition of the fuel cost, as well as its limited incidence on the overall cost of kWh produced, in the following analysis we will refer to a cost of kWh produced due to fuel, intermediate between the two preceding values and equal to **0.00666 US\$/kWh (0.00605 EURO/kWh)**.

The total operation and maintenance cost, assuming conservatively an average load factor of the plant of 85% (this is definitely under-evaluated, if we consider the plant characteristics and its vocation for a base service), results equal to **42,283,000 US\$/year (38,439,000 EURO)**, corresponding to **0.013 US\$/kWh (0.011 EURO/kWh)**.

In view of a preliminary evaluation of the overall production cost for electric energy through a MARS nuclear plant, a hypothesis has been done regarding the financing of the investment necessary for the construction of the plant. The total annual production cost has been, consequently, assumed as a sum of the total yearly operation and maintenance cost, of the fuel cost and of the yearly cost of the debt service. Owing to the nature and to the aim of this analysis, we have considered only one hypothesis of financing, without taking into account a scenario of possible options, including that of self-financing.

If we assume a very realistic hypothesis of repayment of the investment costs during the debt service period (interest rate assumed conservatively equal to 5%/year and repayment of the debt over a period of 20 years, with constant annual rate; constant-value analysis) we obtain a total investment cost, at the date of the starting of the commercial operation of the plant, equal to **955,458,000 US\$ (868,598,000 EURO)** and a constant annual cost, for the reimbursement of capital costs and interests, during 20 years of debt service, equal to **76,668,000 US\$ (69,698,000 EURO)**. This yearly cost affects, for the whole period of the debt service, the cost of electric energy produced, as **0.023 US\$/kWh (0.021 EURO/kWh)**, always in the conservative hypothesis of a load factor of 85% as average value in the year.

Taking into account also the operation, maintenance and fuel costs, in the hypothesis of a load factor 85%, we obtain a total yearly cost of **118,951,000 US\$ (108,137,000 EURO)** during the first 20 years of operation and equal to **42,283,000 US\$ (38,439,000 EURO)** for the following years.

In the conservative hypothesis of a load factor of 85%, corresponding to an average yearly production of about 3,350,000,000 kWh, the yearly cost of kWh produced by the plant with MARS reactors is, therefore, globally, **0.035 US\$/kWh (0.032 EURO/kWh)** during the first 20 years of operation and **0.013 US\$/kWh (0.012 EURO/kWh)** during the following years.

In an hypothesis that is less conservative and more realistic, that takes into account the vocation of this type of plant for a base service and its capability of producing electric energy that, with the minimum length of fuel cycle of 18 months, is 3,734,000,000 kWh/year, the average production cost of kWh becomes **0.032 US\$/kWh (0.03 EURO/kWh)** during the first 20 years of operation and less than **0.012 US\$/kWh (0.011 EURO/kWh)** during the following years.

For the reference power station, the production cost of electric energy is so divided:

- Investment and debt service 64.45%
- Operation and maintenance 16.25%
- Fuel 19.30%

In the view of a sensitivity analysis, the trend of the cost of electric energy produced during the period of the debt service has been studied, with a variation of the length of the debt service period itself. In fig. 7 the results of this sensitivity analysis are reported, for two different values of the interest rate, one conservative but realistic of 5% per year and the other extremely conservative (we remind that the analysis is carried out at constant value of money), of 7% per year, referring, in both cases, to the conservative hypothesis of a load factor equal to 85%.

It is to remark that, in the case of MARS reactors, the possibility of considering very long depreciation periods and therefore very long periods for the repayment of investment cost (debt service) is a realistic option and is absolutely suitable with the nature of this innovative plant. In fact, the technical life of this plant is extremely long, because all the constraints that affect the life of nuclear power plants have been removed. In fact, a traditional nuclear power plant has a technical life that basically depends on the life of the most critical component, i. e. the nuclear vessel or steam generators or other relevant components. The total and simple disassembling of all plant components, including the reactor pressure vessel and the steam generator, allows - in the case of a MARS plant - the substitution of all possible obsolete components and the safe operation of the plant (and therefore of the whole power station) for periods that are extremely long, similarly to the situation of hydro-electric power plants.

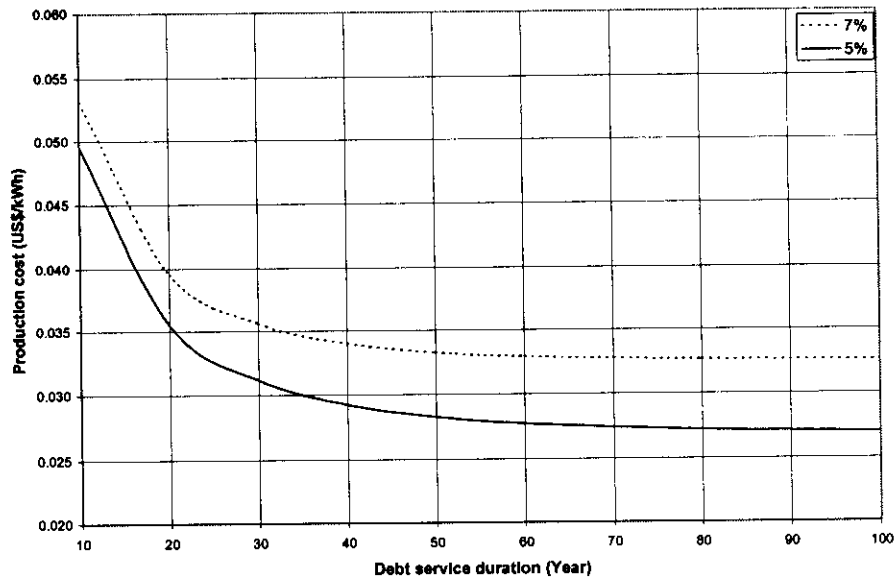

Figure 7 - Average cost of kWh during debt service period vs. debt service period duration (load factor 85%)

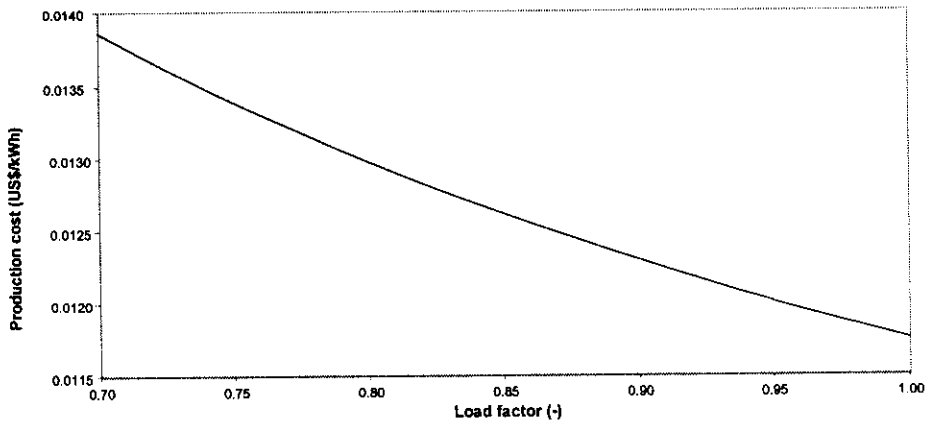

Figure 8 - Average cost of kWh after the debt service period

In this framework, the possibilities and options for what regards the financing mechanism are also extended, in search of solutions that may allow to reduce the already low cost of production of kWh.

The average production cost of kWh after the debt service period depends, on the contrary, only on the load factor of the plant; in Fig. 8 the trend of this dependence is shown.

Even assuming a series of hypotheses that are strictly conservative for the MARS plant, taking into account the specific characteristics of this project, as that of considering the indirect costs analogous (as percentages) to the old traditional nuclear power stations in spite of the huge simplifications of the MARS, or that of the reduced period for the debt service (assumed as 20 or 30 years, while the total possibility of substitution of all components allows a technical life which is quite higher than 60-70 years), or that of limited average yearly load factor (assumed in the economic analysis equal to 85% for a plant that is designed for irradiation cycle of the fuel compatible with load factors of 95%), we obtain a total production cost of kWh equal to **0.035 US\$ (0.032 EURO)**, in the hypothesis of debt service over a 20 year period, and equal to **0.029 US\$ (0.028 EURO)**, in the hypothesis of the debt service over 30 years. This cost, even low and competitive with the cost of kWh produced through the most economic among the other energy sources, refer to the only period of the debt service (20/30 years), because after that period the overall cost of production of the kWh drops down to a value that is of the order of **0.013 US\$ (0.012 EURO)**, and remains stable for a service period that is comparable to the technical life of hydro-electric power stations.

The production of electric energy with nuclear sources through new generation plants designed according to criteria of inherent and totally passive safety, of limited size and hugely simplified, not only brings to great benefits in terms of safety and of limitation of doses to personnel, but results extremely advantageous also under the economic point of view. This is the case of MARS-plant-equipped nuclear power stations.

BIBLIOGRAPHY

1. ECONOMIC COMPETITIVENESS IN ELECTRIC PRODUCTION THROUGH NUCLEAR ENERGY: NEW PERSPECTIVES CREATED BY PLANT SIMPLIFICATION - M. Cumo, A. Naviglio, L. Sorabella, G. Simbolotti - University of Rome, La Sapienza - Dept. of Nuclear Engineering and Energy Conversion
2. NUCLEAR ENERGY DATA - OECD, Paris 1998
3. MARS DESIGN PROGRESS REPORT - University of Rome "La Sapienza", Department of Nuclear Engineering and Energy Conversion, 1997

