

SMR/1328/26

**School on the Physics of Equatorial Atmosphere**  
**(24 September - 5 October 2001)**

*Optical Aeronomy*

**R. Sridharan**  
**(Vikram Sarabhai Space Center, Trivandrum)**



*Temperatures in the upper atmosphere*

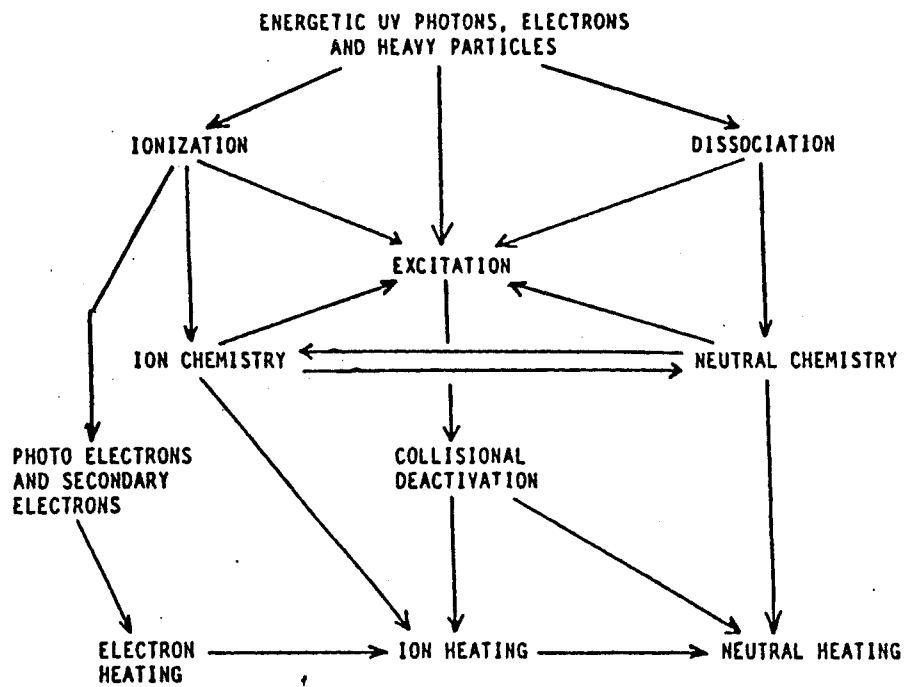
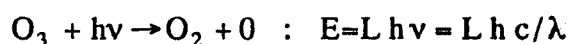

Fig. Physical and chemical processes by which energy carried into the upper atmosphere by UV photons, electrons and ions is channelled into heating of the plasma and neutral gas.

**To understand why visible and UV radiations are important, let us examine the magnitude of one quantum of electromagnetic radiation ie. a photon.**



**Where 'L' is the Avagadro's number**

$$\therefore E = 119625 / \lambda \quad \text{kJ mole}^{-1} \quad \text{or}$$

$$E = 1240 / \lambda \quad \text{eV}$$

$$800 \text{ nm} = 150 \text{ kJ mole}^{-1}$$

**It so happens that the wavelengths at which the chemical changes become possible correspond roughly to the energies at which electronic transitions are excited in atoms and molecules. Longer wavelengths excite the molecules vibrational or rotational levels of molecules.**

## AIRGLOW

Sources located outside our atmosphere and within, illuminate the night sky. Moon, stars, planets and surface lights all contribute to it. Even if the light from all the sources were eliminated, the sky would not still be completely dark. A faint glow would still remain, having its origin in the atmospheric photochemical processes and this faint glow is known as 'airglow'.

**The physical and chemical processes that are responsible for the airglow include**

- (i) Reactions of the neutral constituents**
- (ii) Reactions involving ionized constituents**
- (iii) Excitation of atmospheric constituents by sunlight**
- (iv) Excitation by incoming energetic charged particles guided along the magnetic lines of force.**

**aurorae**

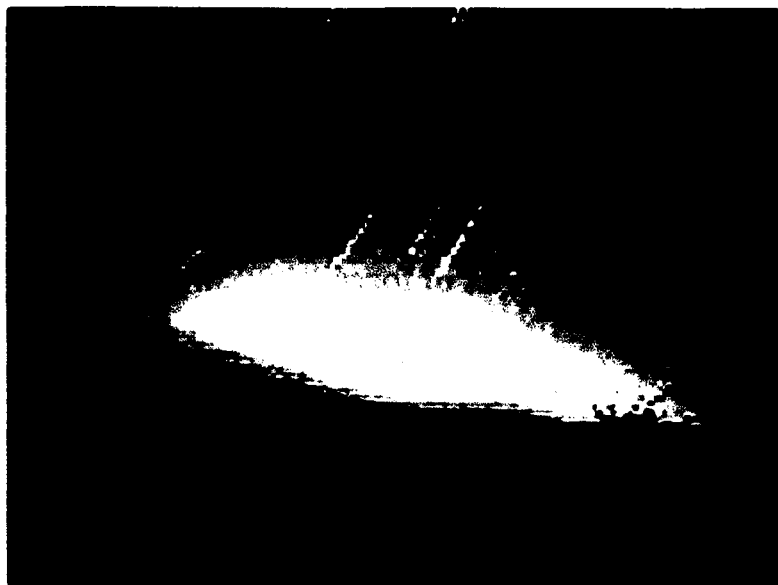



AIRGLOW	AURORA
<p><b>Global in nature</b></p> <p><b>occurs continuously</b></p> <p><b>extremely weak</b></p>	<p><b>Restricted to high latitude:</b></p> <p><b>irregular in shape and structure.</b></p> <p><b>Much more intense (visible to the unaided eye)</b></p>

Though both airglow and aurora are an outcome of the excitation of atmospheric species like,  $N_2$ ,  $O_2$ ,  $N_2^+$ ,  $O$ ,  $N$ ,  $H$ , and  $OH$ , the excitation process are different.

The spectrum mirrors the neutral and ion composition of the region together with the excitation sources. Solar UV photons and auroral particles have sufficient energy to excite, to ionize and to dissociate all species into any accessible electronic state while the exothermicity of chemical reactions is frequently adequate to produce some of the excited states. The low density of the unconfined gas in the thermosphere is conducive to radiation of lines and bands from highly metastable states producing features that could not be seen in the laboratory spectra.



### ***Excitation Mechanisms:***

The excitation processes that are of Aeronomic interest are

- (1) Fluorescence and Resonant scattering
- (2) Excitation by energetic charged particles
- (3) Chemical excitation
- (4) Energy transfer through collision

#### ***(1) Fluorescence and Resonant Scattering***

When an atom or molecule or an ion is excited by absorption of light and if the excited state is stable, the result would be a simple transition back to the ground state or to an intermediate state (cascade process) with the emission of radiation characteristics of the emitting species.

Alternatively, the excited species may dissociate directly, may pre-dissociate or may get ionized in which case an excited ion or radical is formed and it would emit its own characteristic radiation. *In a special case, when the emitted radiation is identical to the incident radiation, Resonance scattering is said to occur.*

**(2) Excitation by energetic particles:**

**There are two main processes involving charged particles**

**(a) Inelastic collision of photoelectrons**

**(b) Electron ion recombination**

**e.g.**

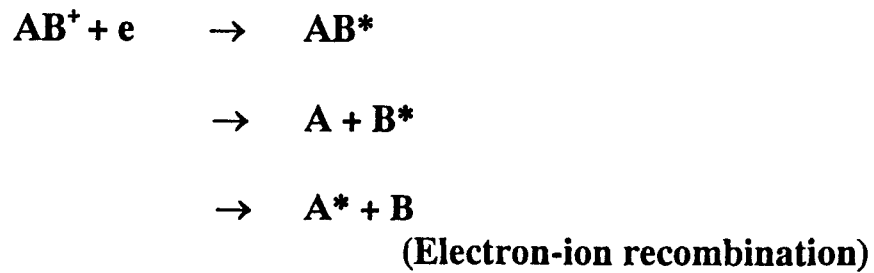
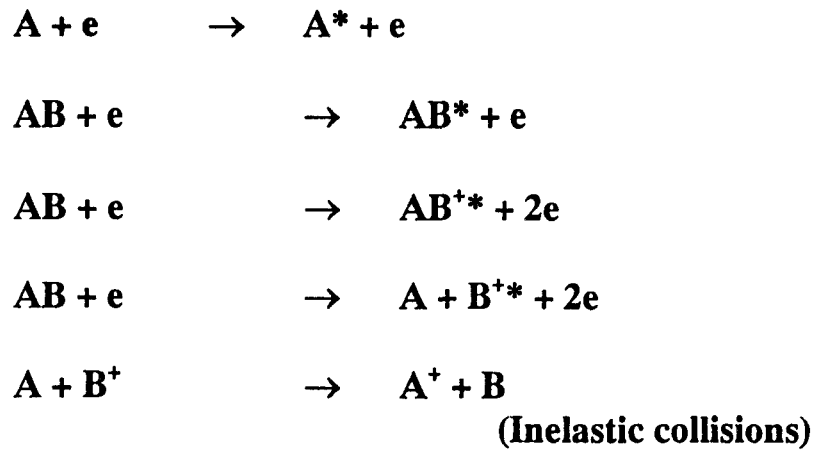

### (3) Chemical Excitation

In an exothermic reaction, some of the excess energy of the reaction may go into *vibrational, rotational or electron excitation* of one or more of the products. Reactions that result in the emission of photons are said to be *chemiluminescent*.

e.g.

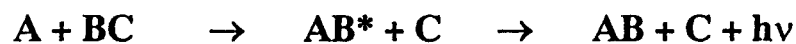
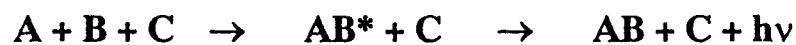
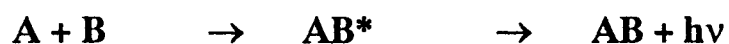

### (4) Energy transfer through collisions

Collisional deactivation (quenching) of an excited species can occur in a variety of ways, one of which involves excitation of the quencher by energy transfer.

## Classification of airglow

The phenomenon of airglow is broadly classified into the three categories based on the time of the day at which the observations are made.

Emissions that are detected during nighttime are termed as 'nightglow' and that during the day as the 'dayglow'.

When the sun is below the horizon at ground level but is in view from an altitude

of 50-150 km, the emissions from the sunlit region of the atmosphere, as seen by

an observer at ground is termed as 'twilight glow'



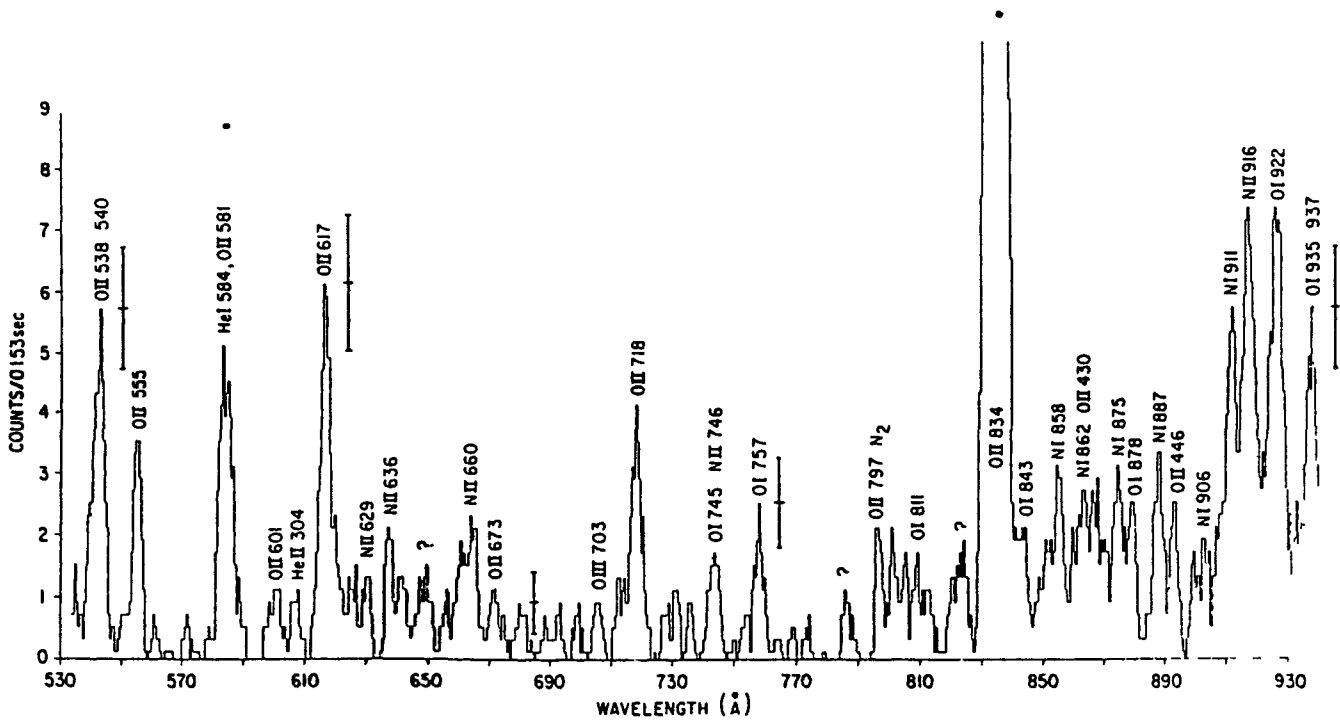

( ) High resolution (3.5 Å) UV dayglow spectrum between 530 and 930 Å acquired with a scanning spectrometer carried by a rocket above White Sands New Mexico (EP Gentieu *et al* *J Geophys Res* 89 11053 1984)

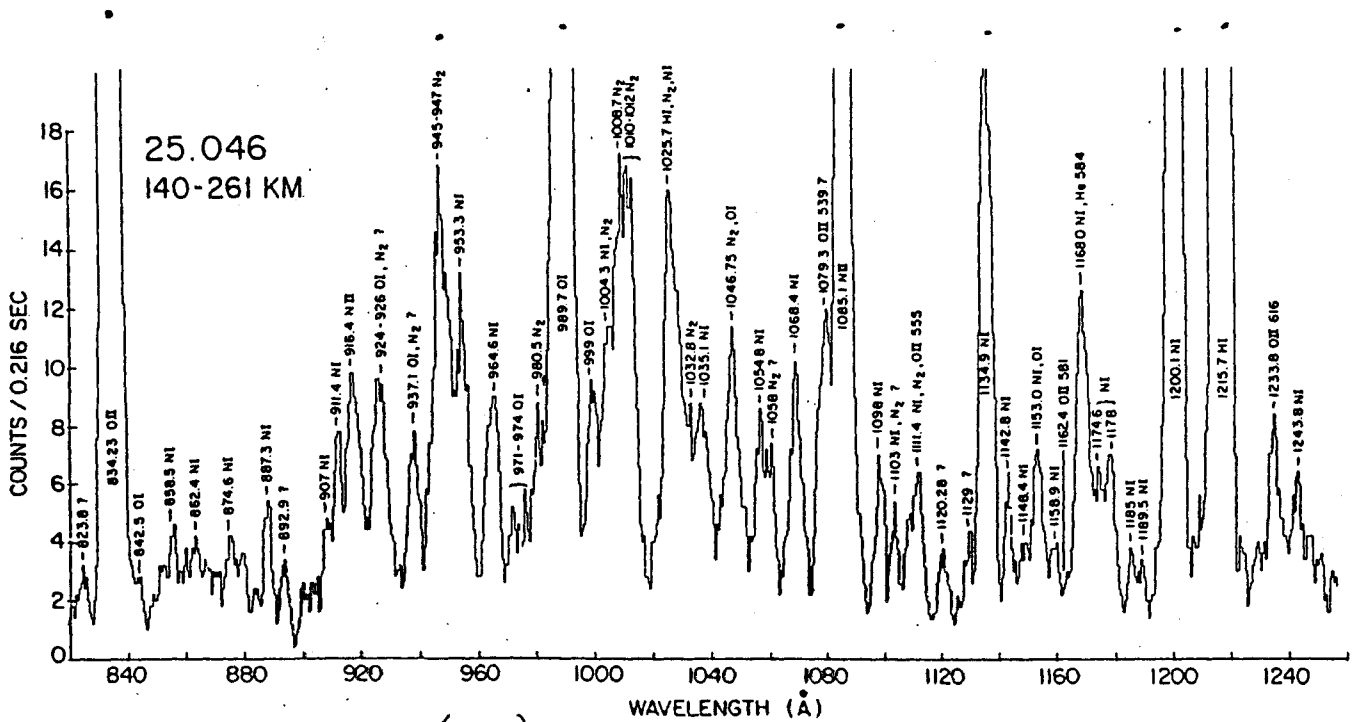

(.) High resolution (3.5 Å) UV dayglow spectrum between 820 and 1250 Å acquired with a scanning spectrometer carried by a rocket above White Sands, New Mexico. (E.P. Gentieu, *et al*, *Geophys. Res. Lett.*, 8, 1242, 1981.)

### The nightglow

During the day the solar radiation is stored in the photodissociation products of the atmosphere. This stored energy is released at night by various recombination and reaction processes many of which result in light emission. The nightglow is then largely the result of chemiluminescent reactions. Resonant scattering plays only a minor role. Some of these emissions are in reality twilight glow as they originate from great heights. Some of the prominent nightglow features are:

**Band system of O<sub>2</sub>**

**Lines of atomic oxygen**

**Atomic nitrogen**

**NO emission continuum**

**Atomic sodium emission**

**Meinel vibration – rotation bands of 'OH' radical etc.**

### *Specific emission sources*

The most important sources pertaining to optical Aeronomy are Emission lines of atomic and molecular oxygen, atomic sodium and Hydroxyl radicals.

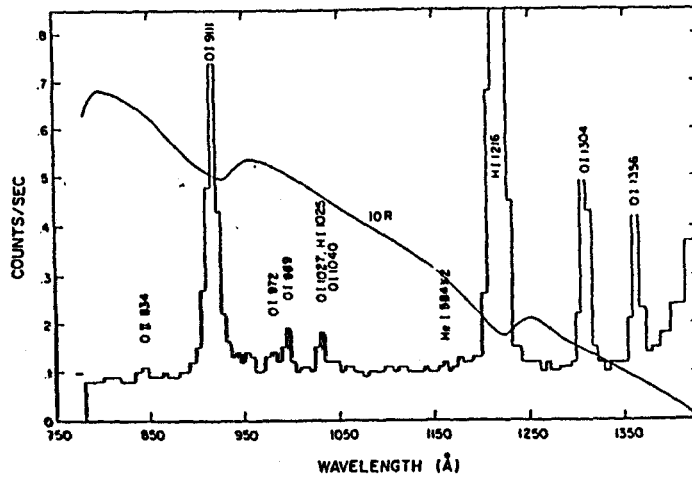

(a) Nightglow spectrum between 750 and 1400 Å: average downlooking UV nightglow spectrum obtained from 600 km when the STP78-1 spacecraft was within  $\pm 30^\circ$  magnetic latitude range and outside the South Atlantic Anomaly region. (S. Chakrabarti, *Geophys. Res. Lett.*, 11, 565, 1984.)

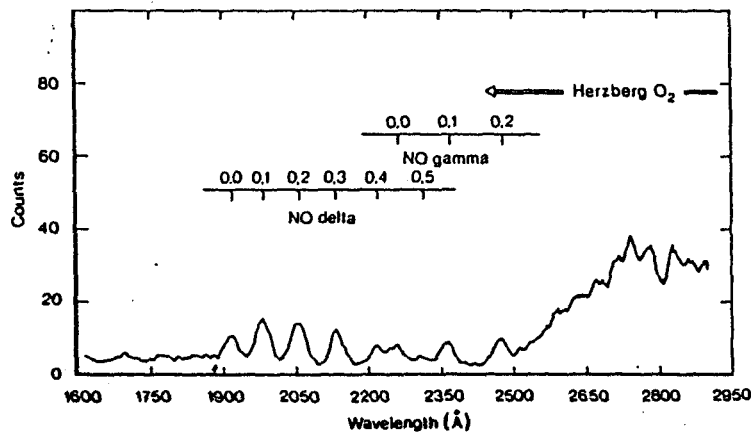

(b) Nightglow spectrum between 1600 and 2950 Å: nadir viewed UV spectrum acquired by the S3-4 satellite in the equatorial region at a resolution of about 25 Å. (R.E. Huffman et al., *J. Geophys. Res.*, 85, 2201, 1980.)

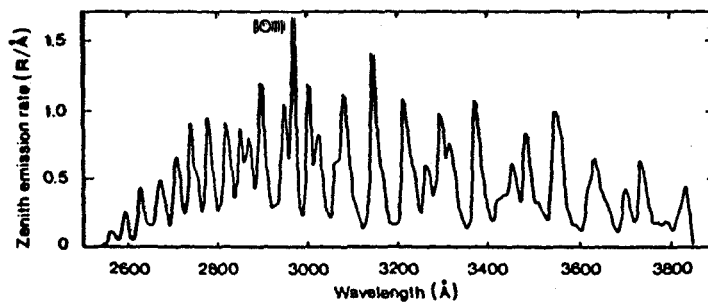

(c) UV night airglow spectrum between 2500 and 3900 Å: acquired by a spectrograph carried on board a rocket launched from White Sands, New Mexico, USA. The resolution is 12 Å. All the spectral features are attributed to the Herzberg band system of  $O_2$ , except for the atomic O line identified at 2972 Å. (J.P. Hennes, *J. Geophys. Res.*, 71, 763, 1966.)

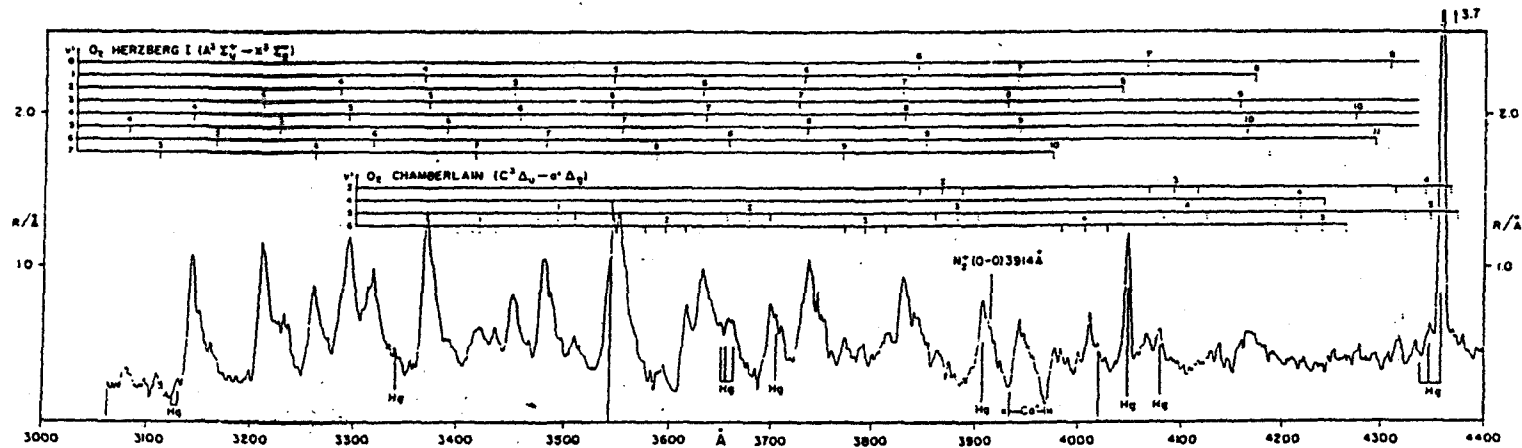

Segments of the night airglow spectrum between 3000 and 4400 Å: acquired with a Fastie-Ebert scanning spectrophotometer from the Kitt Peak, Arizona, observatory at 2080m elevation. The resolution is 5 Å. Several unidentified features appear in the spectrum. (A.L. Broadfoot and K.R. Kendall, *J. Geophys. Res.*, 73, 426, 1968.)

14

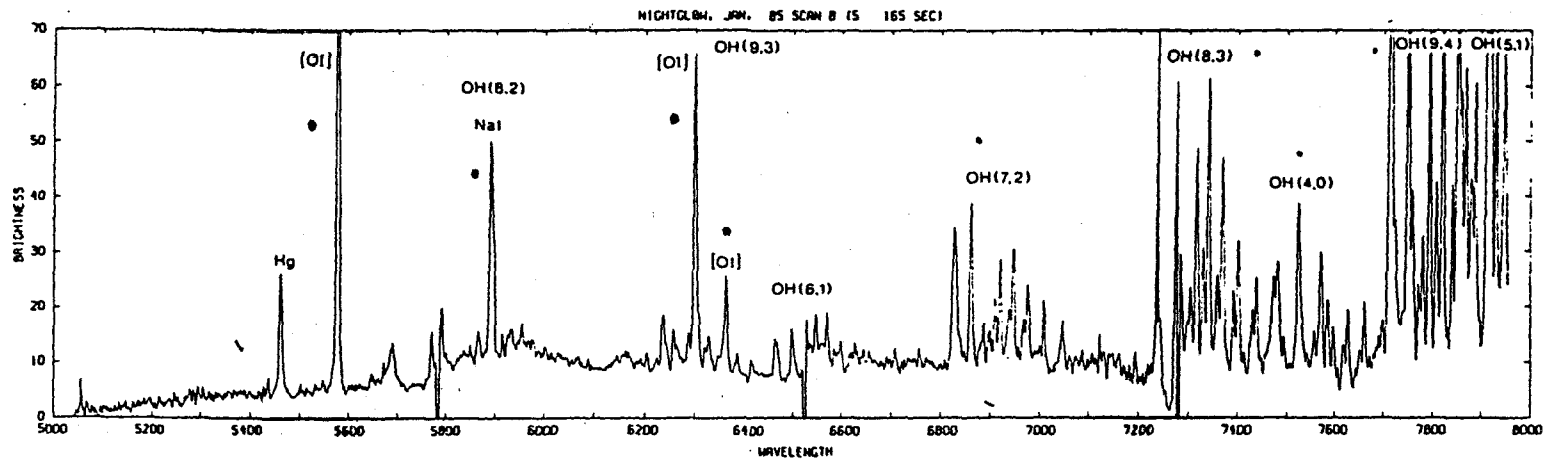

The nightglow spectrum between 5000 Å and 8000 Å acquired in one 14 min exposure at 4 AM LT on January 17, 1985 with an image intensified charge coupled detector on a spectrograph at the Catalina Observatory, Mt. Lennon, Arizona, USA. (Courtesy of L.A. Broadfoot, 1987.)



Atomic and molecular oxygen lines

Excited states of 'O' and 'O<sub>2</sub>' make an extremely important contribution to the airglow of the Earth and other planets.

All the relatively long wavelength transitions are forbidden by electric dipole selection rules and therefore the excited states are in a 'meta stable state'.

The O (<sup>1</sup>S - <sup>1</sup>D) transitions at λ=5577A was the first component of the airglow to be identified by high-resolution spectroscopy, with a specific atomic or molecular event. Both the green line and the Red doublet at λ= 6300 A and at 6364 A due to O (<sup>1</sup>D - <sup>3</sup>p<sub>2,1</sub>) transition arise from two different altitude regions of the atmosphere.

Photo electron impact and dissociative recombination could result in the production of O<sup>1</sup>S and O<sup>1</sup>D states

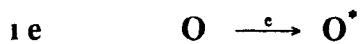

And

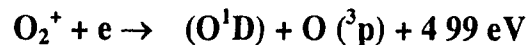
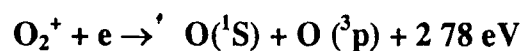

It may be recalled that the Dissociative recombination is one of the prominent neutralizing process in the F-region.

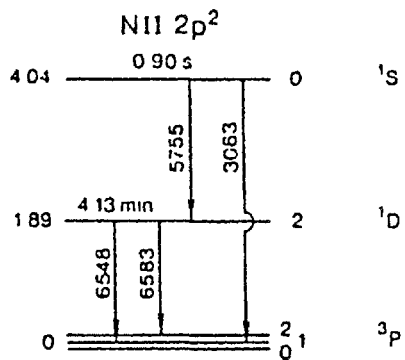
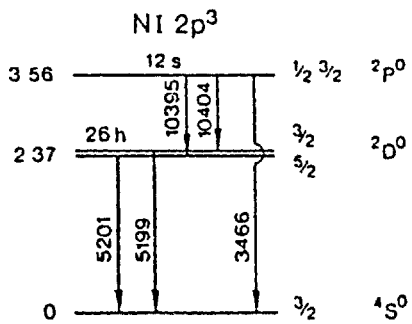
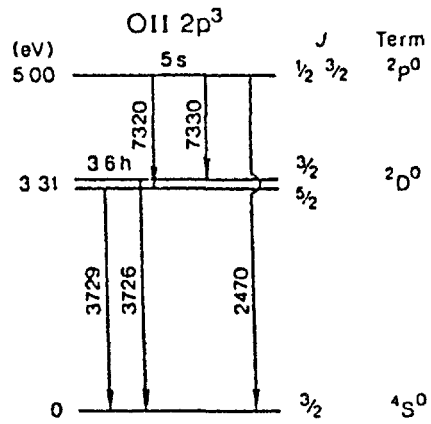
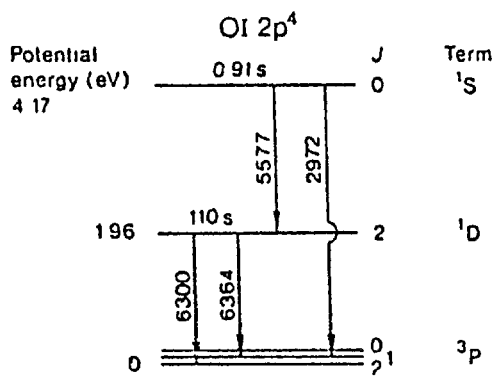

Partial energy level diagrams for O  $O^+$ , N and  $N^+$  showing states in the ground configuration of the atoms and ions

As for the Red line 6300 Å and 6364 Å are concerned photoelectron excitation, of atomic oxygen, photo dissociation of molecular oxygen and Dissociative recombination of  $O_2^+$  are the main sources (of O ( $^1D$ )). Though the production due to these agencies independently maximizes at different heights, the long life time of this metastable species (~110s) and the collisional quenching at lower altitudes results in the emission layer maximum to be in the altitudes region of 200 km and above.

As for the 'green line', it is believed that it should be an outcome of a three body reaction

Two of the proposed mechanisms are

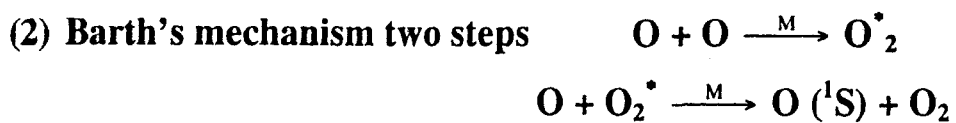

Both these schemes predict a production rate of O ( $^1S$ )  $\propto [O]^3$ .

Presently Barth's mechanism is more favoured.

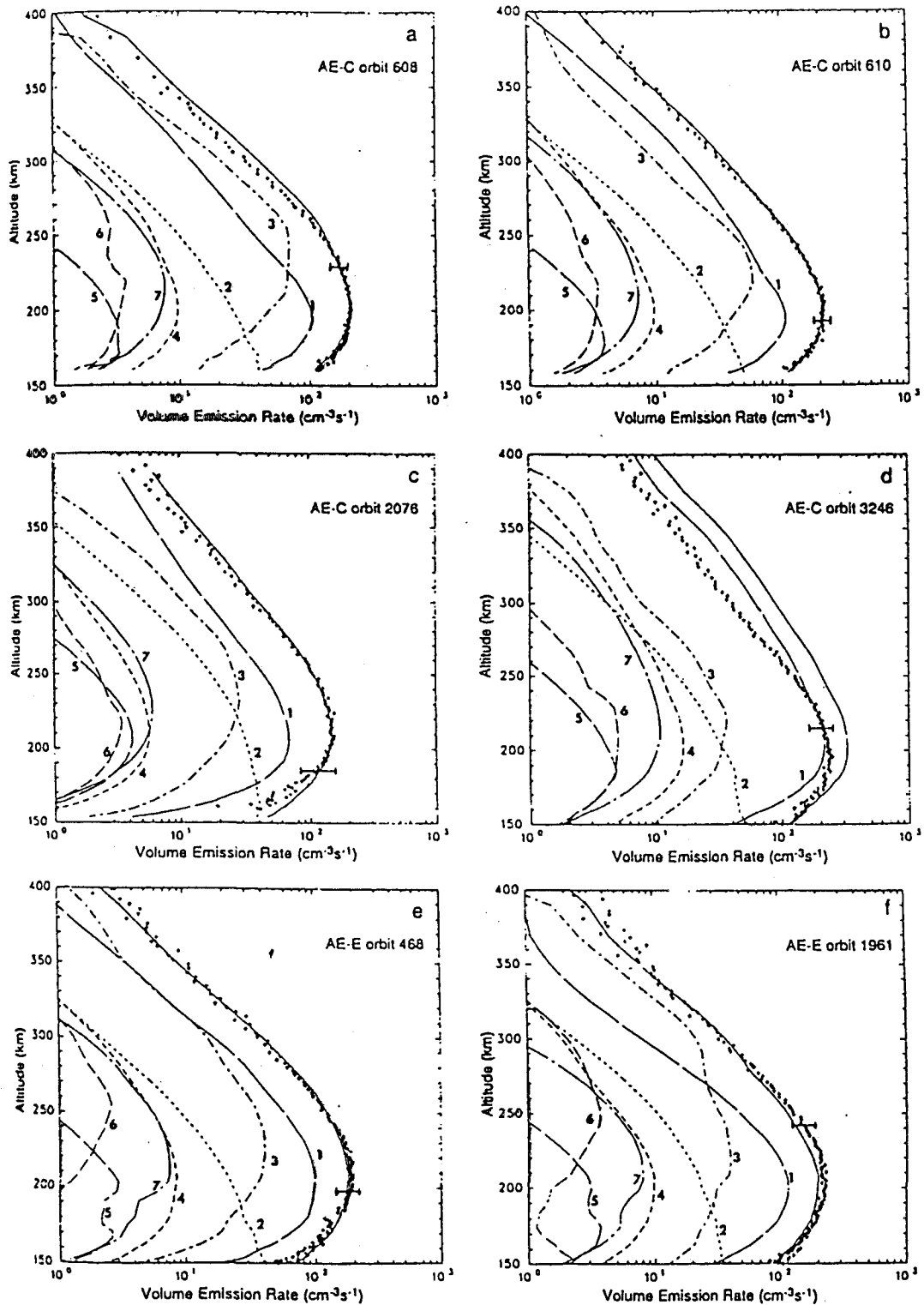

Figure 3.7. Measured and modeled 630 nm volume emission rate profiles. Inverted measurements from the VAE experiment are represented with pluses. Total modeled emission is shown with a solid line. Contribution sources (1)  $e^+ + O$ ; (2)  $h\nu + O_2$ ; (3)  $O_2^+ + e$ ; (4)  $O(^1S)$ ; (5)  $N(^2D) + O_2$ ; (6)  $N^+ + O_2$ ; (7)  $N(^2D) + O$ . (After Solomon and Abreue, 1989)

Recombination of ground state 'O' to form  $O_2^*$  could in principle populate any or all of the singlet, triplet and quintet molecular states that correlate with  $O(^3p)$ . Excitation of O ( $^1S$ ) requires 4.19 eV. Different vibrational levels at and above this energy would then play an important role in the formation of O ( $^1S$ ) atoms.

### Atomic Sodium emissions

Airglow emissions from atomic sodium and other metals are of interest because the allowed resonance transitions fall within the visible regions and are therefore observable from the earth's surface

Metallic atoms and ions have been observed considerably in the D and E region of the ionosphere by rocket borne mass spectrometers and the meteoric ablation is believed to be the primary source around 85-100 km. The mesospheric layer of neutral sodium is located ~ 93 km with normal peak concentration of  $3 \times 10^3 \text{ cm}^{-3}$ , which generally increases during peak meteoric activity periods

Daytime direct excitation by the solar radiation yields doublet intensities of the order of 30 kR

Using Sodium Lidars one could artificially excite the sodium atoms and determine the altitude profile

During night hours, the intensities are very weak (~ 100 R only) -- mainly due to chemiluminescence. This would call for a replenishing source

An Oxidation/reduction cycle is a possibility involving NaO.



Followed by



### Hydroxyl Radicals

The 'OH' radicals contribute significantly to the long wave and near infra Red airglow – a rare example of vibrational rather than electronic excitation airglow – Extremely important with regard to O<sub>3</sub> chemistry.

These emissions are called as the Meinel bands of OH



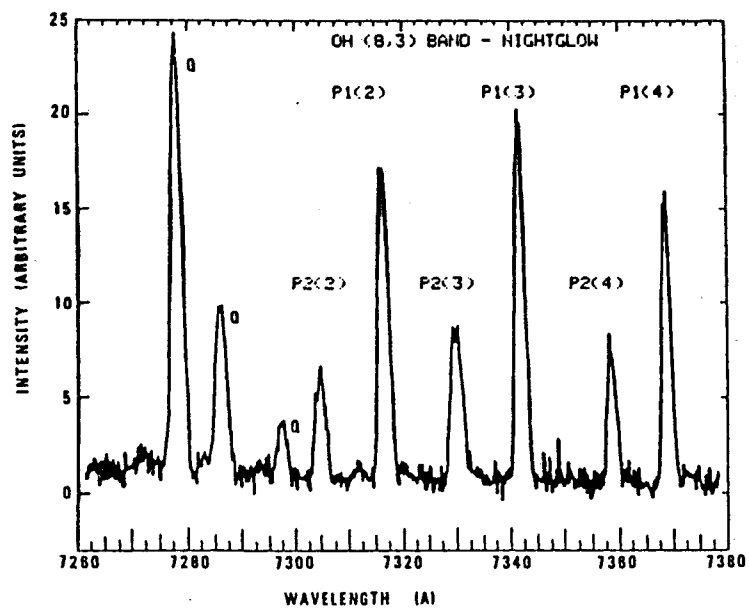

Spectrum of the OH (8,3) band observed in the nightglow between 7260 and 7380 Å.

### Utilities of Airglow measurements

The spectral lines and bands that constitute airglow are invaluable means of remotely sensing several physical processes and properties of the emitting regions.

- The **absolute** emission rate combined with the excitation cross sections can yield the column density of the species or the intensity of the sources that produce the excited state.
- Doppler profiles and line shifts of certain radiations lead to temperatures and line of sight winds or ion drift velocities.
- Vibrational rotational distribution in molecular bands yields the respective temperatures or provides insight into the possible excitation mechanisms.

It is well known that the different atmospheric regions are mutually coupled through a variety of processes, which would have its imprint in the airglow emissions too.

*Many Spectroscopic emission features could therefore be usefully employed provided that their origin is well understood and the perturbing effects if any are properly taken into account.* The altitude of emission is one of the fundamental parameters.



Emission from an excited species  $A^*$  is described by a rate law.

$$I = k_r [A^*] \quad (3)$$

Where  $I$  is the total emission rate in photons/unit volume/unit time.

The rate coefficient  $k_r$  refers to the transition probability

A radiative lifetime is often defined as  $\tau$

$$\text{given by } \tau = \ln 2 / k_r$$

To a first approximation ' $k_r$ ' is independent of pressure.

Radiation is an isotropic process, so that each volume element of the airglow emits equally in all directions. An observer or an instrument perceives a brightness that depends on the photon flux/area/sec. For this reason, the airglow brightness is usually measured in Rayleigh ( $R = 10^6$  photons/cm<sup>2</sup>/s) in all directions. For an optically thin medium  $I$  need be multiplied by the depth of the emitting layer to give the Rayleigh brightness. (The depth to be measured in units of 10 km).

- Intensities of airglow are related to atmospheric concentrations of excited species through the transition probability  $k_r$ .
- Large intensities of strong emitters need not necessarily mean larger concentrations than lower intensities of weak emitters.

e.g; A hypothetical case

Consider an airglow layer of 10 km thick with N, atomic nitrogen as the emitter. The dayglow intensity of 5200A is of the order of 90 R.

But the  $k_r$  for this highly forbidden transition is  $k_r = 7.4 \times 10^{-6} \text{ s}^{-1}$  correspondingly to a lifetime of 26 hours.

$\therefore$  Therefore concentration of  $[N^*]$  will then be

$$I = k_r [A^*] \text{ to } \frac{90}{7.4 \times 10^{-6}} \sim 10^7 \text{ cm}^{-3} \quad (4)$$

On the other hand emission from sodium atoms during daytime is ~ 300 times more intense is ~ 30 KR. However  $k_r = 6.3 \times 10^7 \text{ s}^{-1}$  (life time of 12 nano second) which would mean the concentration of ~  $4.8 \times 10^{-4} \text{ cm}^{-3}$  only.

*Once an excited species is produced, radiative decay competes with the production of the emitting species.*

*There are additional loss processes, non-radiative intra and inter molecular processes. Physical quenching is one of the important loss processes.*

*In short excitation – deexcitation – non radiative quenching – all these processes act simultaneously and the emission of airglow is a highly dynamical process.*

If the quencher is 'M' and the quenching rate is 'k<sub>q</sub>', the generalized excitation and de excitation mechanism becomes

Source → A\* - excitation rate = P

A\* → A + hν - emission rate = k<sub>r</sub> [A\*]

A\* + M → A + M - quenching rate = k<sub>q</sub> [A\*] [M]

If the excitation rate does not change rapidly a steady state is soon arrived at

$$\begin{aligned}
 P &= k_r [A^*] + k_q [A^*] [M] \\
 &= [A^*] [k_r + k_q [M]]
 \end{aligned}
 \tag{5}$$

$$\therefore A^* = P / [k_r + k_q [M]]
 \tag{6}$$

$$\begin{aligned}
 I &= k_r [A^*] = k_r P / [k_r + k_q [M]] \\
 &= P / \left[ 1 + \frac{k_q}{k_r} [M] \right]
 \end{aligned}$$

(Physical transport is ignored)

From the above it could be seen that for any given excitation, the quenching eventually decides the airglow intensity.

The quenching depends on  $\frac{k_q [M]}{k_r}$  knowing k<sub>q</sub>, k<sub>r</sub> and [M], the altitude profile could be obtained.

**e.g.: For Nitrogen  $k_r < 10^{-5} \text{ S}^{-1}$  and  $k_q = 10^{-11} \text{ cm}^3$  quenching dominates at all heights.**

**Therefore the radiation would become dominant only when  $[M]$  is of the order of  $10^6 \text{ mole/cm}^3$  i.e.  $> 500 \text{ km}$  only. The peak of the emission lies  $\sim 200 \text{ km}$  where  $[M] \sim 10^{10}$ , implying only one out of  $10^4$  excited species would radiate.**

**Another important aspect of airglow emitting layer is that its lower boundary is always sharply defined by increasing rates of quenching acting together with decreased rate of excitation.**

## *Airglow and the Ionosphere*

On the basis of the excitation mechanisms, and the photochemical processes, much could be learnt about the ionosphere and vice versa.

Barbier proposed an empirical relation associating the tropical airglow with the F-region maximum electron density during night time as

$$Q(6300\text{\AA}) = A + B(f_0F_2)^2 \exp\left(\frac{-h'F_2 - 200}{H}\right)$$

Where  $(f_0F_2)^2$  is proportional to the peak electron density and  $h'F_2$  is the virtual height of the base of the  $F_2$  layer during night. A and B are empirical constants and 'H' is the scale height.

The airglow intensity measurements could be used to study the equatorial ionization anomaly, equatorial spread F, midnight temperature max, ionosphere thermosphere coupling, middle atmosphere – upper atmosphere coupling, ionospheric/atmospheric dynamics and thermal structure, stable Auroral Red Arcs, Polar Cap absorption Rotational temperatures, densities of minor constituents and the like in addition to the physical and chemical processes that are responsible for the emission.

The measurement of airglow has been accomplished by means of a variety of techniques like, photometers high-resolution spectrometers, Imaging systems and also by means of imaging high-resolution spectrometers.