



INTERNATIONAL ATOMIC ENERGY AGENCY  
UNITED NATIONS EDUCATIONAL, SCIENTIFIC AND CULTURAL ORGANIZATION  
**INTERNATIONAL CENTRE FOR THEORETICAL PHYSICS**  
I.C.T.P., P.O. BOX 586, 34100 TRIESTE, ITALY, CABLE: CENTRATOM TRIESTE



H4.SMR/473-20

## COLLEGE ON NEUROPHYSICS

**"Neural correlates of behaviour, development, plasticity and memory"**

1-19 October 1990

***Why does the brain have so many visual areas?***

**John H. Kaas  
Vanderbilt University  
Nashville, USA**

# Why Does the Brain Have So Many Visual Areas?

**Jon H. Kaas**

Department of Psychology  
Vanderbilt University, Nashville

## **Abstract**

Mammals vary in number of visual areas from a few to 20 or more as a result of new visual areas being added to the middle levels of processing hierarchies. Having more visual areas probably increases visual abilities, perhaps in part by allowing more stimulus parameters to be considered. Proposals that each visual area computes and thereby "detects" a specific stimulus attribute have so far dealt with attributes that most mammals can detect and thus do not relate to the issue of species differences in numbers of areas. The problem of forming and maintaining complex patterns of interconnections between many different sets of distinct processing models within an area may limit multiplying functions within a field. In addition, the adding of new visual areas is a way of avoiding constraints on modifying existing visual areas that are imposed by the ongoing functional requirements. Thus, increasing the number of visual or other cortical areas is an effective and apparently common mechanism for evolving new capacities.

## **Introduction**

The visual system of an advanced mammal, such as a macaque monkey, includes a number of subcortical and cortical centers (see Kaas & Huerta, 1988 for review). The retina projects to the suprachiasmatic nucleus, the pregeniculate nucleus, the lateral geniculate nucleus, nuclei of the accessory optic system, the pretectal nuclei, and the superior colliculus. Most of the very large pulvinar complex, which includes at least 7 or 8 nuclei, is also involved in vision. Parts of the reticular nucleus, the basal ganglia, pons, and cerebellum are predominately visual in function, and the parabigeminal nucleus and oculomotor nuclei of the brain stem are visual centers. But much of visual processing, especially processing related to conscious aspects of vision, occurs in visual cortex, where some 15-30 visual areas participate. An obvious question, given this multiplicity, is why so many areas?

Of course an obvious question is not often new. Cowey (1981), for example, titled a paper "Why are there so many visual areas?" Kaas (1982) subtitled a paper "Why do sensory systems have so many subdivisions?", and Barlow (1986) recently asked "Why have multiple cortical areas?". Cowey (1981) noted that "the answer to the question . . . is not clear" and "that is why it is worth discussing." The general consensus is that the different visual areas are specialized to mediate different aspects of

vision, but there are varying opinions about the nature of these different aspects, and about what is gained by increasing the numbers of visual areas. The present paper considers what is a visual area, how species vary in numbers of visual areas, and the possible advantages of having larger numbers of visual areas.

## **1. What is a Visual Area?**

Brodman (1909) regarded cortical areas as the "organs" of the brain, with specific functions or sets of functions. Because of their functional distinctiveness, the "organs" of the brain were expected to differ in histological structure, and Brodman used architectural differences in the brains of humans and a wide-range of other mammals to parcel cortex into areas of presumed functional significance. Eight decades of subsequent research support Brodman's assumption that cortex is sharply divided into a mosaic of functionally distinct areas or fields. However, the architectonic method, when used by itself, is often unreliable.

Because the architectonic method and other approaches all have the potential for error, cortical areas are most reliably defined by multiple criteria. If cortical areas are functionally distinct subdivisions of the brain, areas are likely to differ along a number of parameters including histological structure, connections, and neuron properties (see Kaas, 1982). In addition, areas in sensory systems often systematically represent a sensory surface. If a region

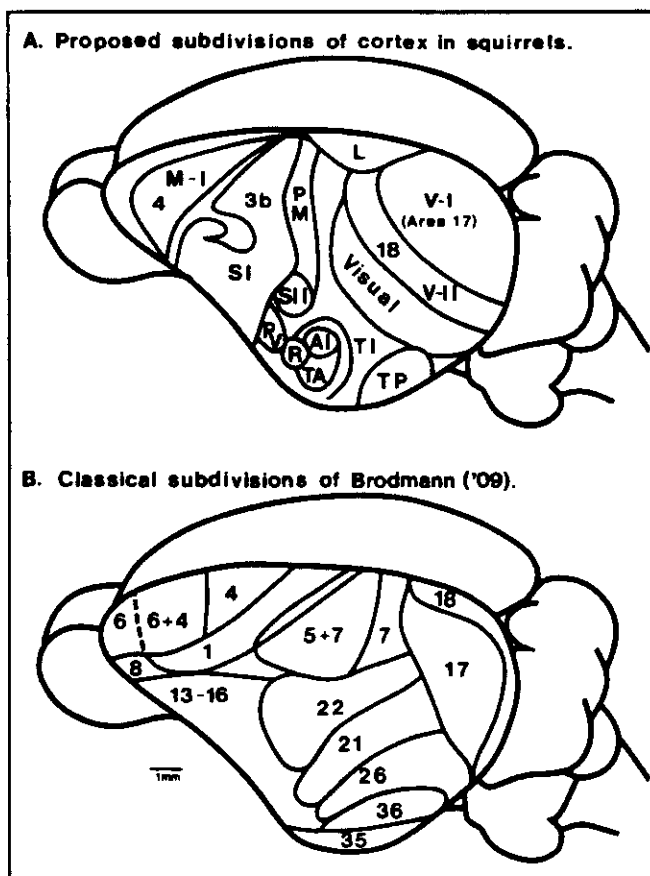

**Figure 1.** Current (A) and classical (B) views of how neocortex of squirrels is subdivided into areas. A. Some of the proposed areas are supported by a convergence of evidence from microelectrode recordings or stimulation, architectonic studies, and studies of connections. Other proposed subdivisions are based on more limited evidence. See text and Kaas et al., 1989 for details. B. Subdivisions of cortex according to the cytoarchitectonic studies of Brodmann (1909). Note that there is little correspondence with the modern view other than the partial overlap of primary visual cortex (area 17) and primary motor cortex (area 4 or M-I), and that Brodmann recognized no primary somatosensory (area 3b or S-I) or auditory (area 41 or A-I) fields. Brains are dorsolateral views with rostral (olfactory bulbs) to the left.

of the brain contains a complete and orderly representation of the hemiretina (or contralateral visual hemifield), is histologically distinct (a wide range of procedures are now available, including traditional stains for cell bodies or myelinated fibers as well as more recently developed reactions for metabolic enzymes and neurotransmitters), has unique patterns of inputs, outputs and intrinsic connections, has a population of neurons with distinctively different response properties, and deactivation produces specific impairments, then the region is likely to be a valid visual area.

Early investigators, largely limited to relating histological appearance to rather sparse evidence from experimental animal studies and clinical reports, produced brain maps that differ greatly from current maps. In any study, the significance of architectonic distinctions can be misin-

terpreted so that parts of areas can be considered to be complete areas, a single area can be incorporated into several different fields, several fields can be incorrectly combined (e.g., borders misidentified), and identified subdivisions can be incorrectly homologized across species (see Kaas, 1982). Brodmann, because of the extent of his studies, and the number of species considered, has had great and lasting impact, even though his brain maps correctly identified only a few sensory areas of the cortex. For visual cortex, Brodmann usually, but not always, identified the primary field, V-I (his area 17), sometimes located the second field, V-II (his area 18), but failed to identify any of the other of the currently recognized visual fields (with the possible exception of "area 19" as V-III in cats). In proposing subdivisions of cortex in squirrels (Fig. 1B), Brodmann (1909) correctly identified part of the primary field, V-I or area 17, but incorrectly identified the less developed medial portion of area 17 that is devoted to monocular vision as the second field, area 18 (V-II). No primary somatosensory field (area 3b) or primary auditory field (area 41) was found, and only part of the primary motor field (area 4) was identified. Most other proposed subdivisions have little relationship to present understandings of cortical organization. The point is not to devalue the contributions of Brodmann and other earlier investigators, but to stress the potential for error when only one method is used to subdivide the brain. The older, highly inaccurate maps are part of our scientific legacy, but further progress depends on evaluation, revision, and replacement. Given the power of current methods, especially when used in combination, there is no need to rely on the proposals and guesses of the past.

Current maps of the neocortex of a common rodent, the grey squirrel, illustrate some of the basic progress that has been made in defining cortical areas, and some of the questions that remain (Figure 1A; see Krubitzer et al., 1986; Luethke et al., 1988; Kaas et al., 1989b). The primary visual area, V-I or area 17, has been defined by many criteria, including cyto- and myeloarchitecture, histological procedures such as reactions for cytochrome oxidase activity, microelectrode recordings that reveal a topographic representation of the contralateral visual hemifield, and systematic patterns of connections with other cortical and subcortical structures. The second visual area, V-II or area 18, has also been delimited by the same set of multiple criteria. More laterally, cortex defined as visual has interconnections with V-I and V-II, but it is presently uncertain if the region is one or several visual fields. In the caudal temporal lobe, presumptive areas TI and TP are architectonically distinct, and have connections with the visual pulvinar, but more evidence is needed to determine if they correspond to functionally distinct visual areas. Elsewhere, primary motor cortex, M-I, somatosensory fields S-I, S-II, and PV, and auditory areas A-I and R have been defined by multiple criteria, while other proposed subdivisions are supported by more limited evidence. However, methods for obtaining more evidence are available, and

further investigation can and should modify and improve the map. Similarly, in other mammals such as cats and various monkeys, the evidence for proposed subdivisions varies area by area.

## 2. Are There Many Visual Areas?

The question of number of visual areas is part of a larger issue of how many areas of cortex exist. Until recently, one could be a "lumper" or a "divider" and propose that there are few or many brain areas, since there was no unequivocal way to evaluate the various proposals based on architectonic appearance. The two major contributors to theories of cortical organization, Brodmann (1909) and von Economo (1929) agreed that the number is species variable, an increase represents an advance in evolution, and that the human brain has on the order of 50 or more areas. Other estimates for the human brain were of over 200 areas. Lashley, in contrast, argued that there was little reason to believe that rats and humans differ in number of fields, and that the brains of both contain about ten areas (e.g., Lashley & Clark, 1946). We now have strong evidence that primitive mammals with small brains and limited behavioral range have few cortical areas, perhaps as few as 10–15, while advanced mammals with large brains and considerable behavioral range have many cortical areas (50–100 or more).

The common European hedgehog, an insectivore, is an example of a mammal with very few cortical areas (Figure 2). The brain is small, and it has very little neocortex, no more than a cap on the rest of the forebrain and about the same amount as the first mammals, as suggested from endocasts of the brain cavity. In hedgehogs, microelectrode recordings and stimulations have demonstrated first and second visual areas, motor cortex, first and second somatosensory areas, and an auditory region (see Kaas, 1987a). The auditory region may contain two or more fields, there is room in temporal cortex for one or two additional visual fields, a taste area remains to be identified, a supplementary motor field may exist medially, there appear to be several orbitofrontal and midline limbic fields, and transitional cortex is found along the rhinal fissure. Altogether, hedgehogs get along just fine with probably 10–15 cortical areas, as Lashley supposed for all mammals. Of course hedgehogs do this without being tremendously flexible in behavior. They wander about appearing to find carrion and other helpless food largely by accident, and escape danger by rolling into a ball of spines. Thus, the Greek poem from about 680–640 B.C. "The fox knows many tricks, the hedgehog only one. One good one!"

The upper limit on the number of cortical areas in hedgehogs can be deduced from the strong evidence for the location and existence of some areas and the fact that there isn't much cortex in addition to these fields. Another example is the cortex of the common mouse, where we have some concept of cortical organization based on experimental data from mice and rats. The small amount

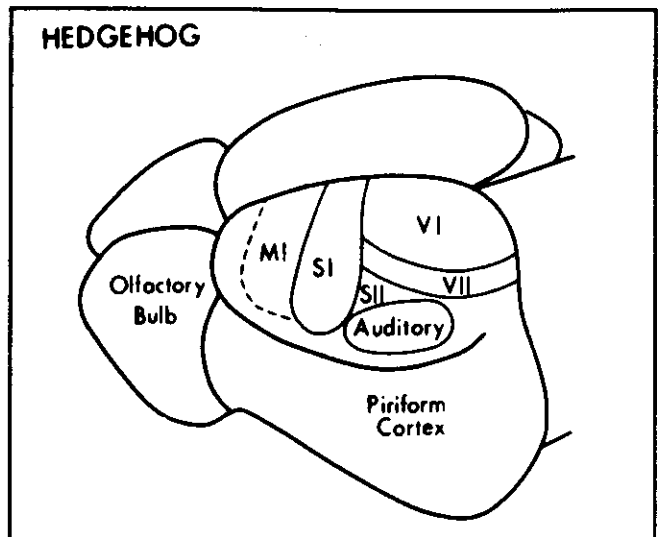

**Figure 2.** Proposed areas of neocortex in hedgehogs, an insectivore with proportionately little neocortex and few cortical areas. Primary (V-I) and secondary (V-II) visual areas, primary (S-I) and secondary (S-II) somatosensory areas, a motor field (M-I) and an auditory region have been identified, and there is little room for additional areas. While temporal cortex caudal to the auditory region may be visual, the hedgehog appears to have only a few (3-5) visual areas. A dorsolateral view of the brain. Modified from Kaas, 1987.

of neocortex can be easily removed, flattened between glass plates, sectioned parallel to the surface, and stained to reveal myeloarchitectonic fields that have been previously related to sensory representations (Figure 3; see Kaas et al., 1989b; Krubitzer et al., 1986, for review). Again, the conclusion is clear. Mice have few cortical areas, on the order of 10–15, and at best 3–5 visual areas (Wagor et al., 1980; however see Montero et al., 1973).

Behaviorally advanced mammals with larger brains certainly have more fields. The best examples come from the domestic cat, several species of New World monkeys, and Old World macaque monkeys where considerable experimental evidence has been gathered (see Kaas, 1989a for review). Cats appear to have as many as 10–15 visual areas, five somatosensory areas, and at least eight auditory areas. Monkeys also have large numbers of cortical areas, especially visual areas, and it is probable that higher primates including humans have even more.

Much of our research on the organization of cortex has been on the relatively small-brained New World monkey, the night or owl monkey (*Aotus*). In this monkey, the cortex can be removed and flattened, much as in the mouse, by placing a cut in primary visual cortex (area 17) so it can spread out (Figure 4). In this form, all of neocortex can be viewed as a single, flat sheet with only slight distortions produced by flattening. Fiber stains and other histological procedures provide landmarks so that experimentally determined fields can be superimposed on the flattened cortex with considerable accuracy.

The caudal half of the cortex in owl monkeys contains

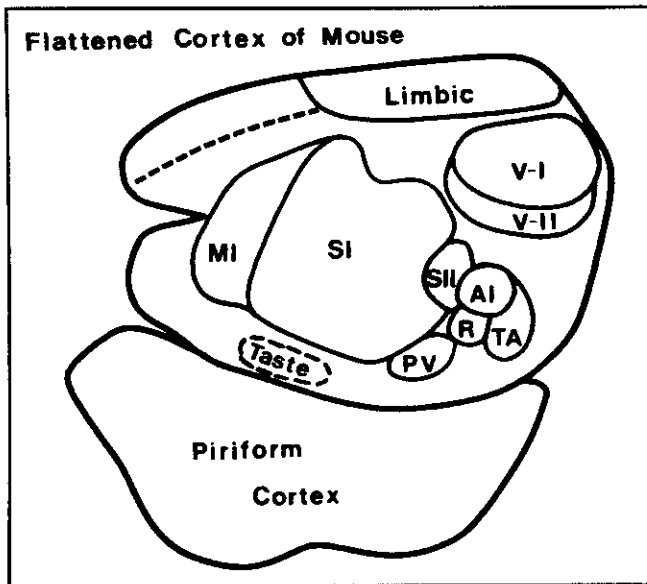

Figure 3. Some of the subdivisions of neocortex in a mouse. The drawing is based on architectonic distributions apparent in cortex that has been separated from the brain, unfolded, flattened between glass plates, and cut parallel to the surface. Somatosensory fields (S-I or primary somatosensory cortex, S-II or secondary somatosensory cortex and PV or parietal-ventral), the visual fields (V-I or primary visual, V-II or secondary visual), motor field (M-I), and auditory fields (primary or AI, rostral or R, temporal anterior or TA) have been identified in microelectrode mapping studies where results were related to architecture in rodents (see Krubitzer et al., 1986; Luethke, et al., 1988; Kaas et al., 1989 for reviews). Because of the flattening, cortex of the medial wall including limbic cortex is to the top and parts of piriform cortex are at the bottom. The olfactory bulbs are missing. Rostral is left.

a large number of visual areas (see Kaas, 1986 and 1989a for review). The experimental support is extensive for the existence, location and extent of the primary field (V-I or area 17), the secondary field (V-II or area 18), and the middle temporal visual area (MT). Other proposed subdivisions have less compelling and varying amounts of experimental support. Thus it is likely that the present scheme will be modified, and given the history of progress in this type of research, several of the larger fields will prove to be composed of more than one visual area. However, there is now evidence for about 15 visual areas in caudal neocortex and at least 3 visuomotor areas in the frontal lobe. Similar numbers of visual areas have been proposed for macaque monkeys, where different groups of investigators have produced somewhat different summaries and use partially different terminologies (Figure 5; see Van Essen, 1985; Desimone & Ungerleider, 1986). The clear conclusion, however, is that these advanced mammals, cats and monkeys, have on the order of 15–30 visual areas.

### 3. What Do Neurons in Visual Areas Do?

There is general agreement that neurons in different visual areas respond to visual stimuli with different response

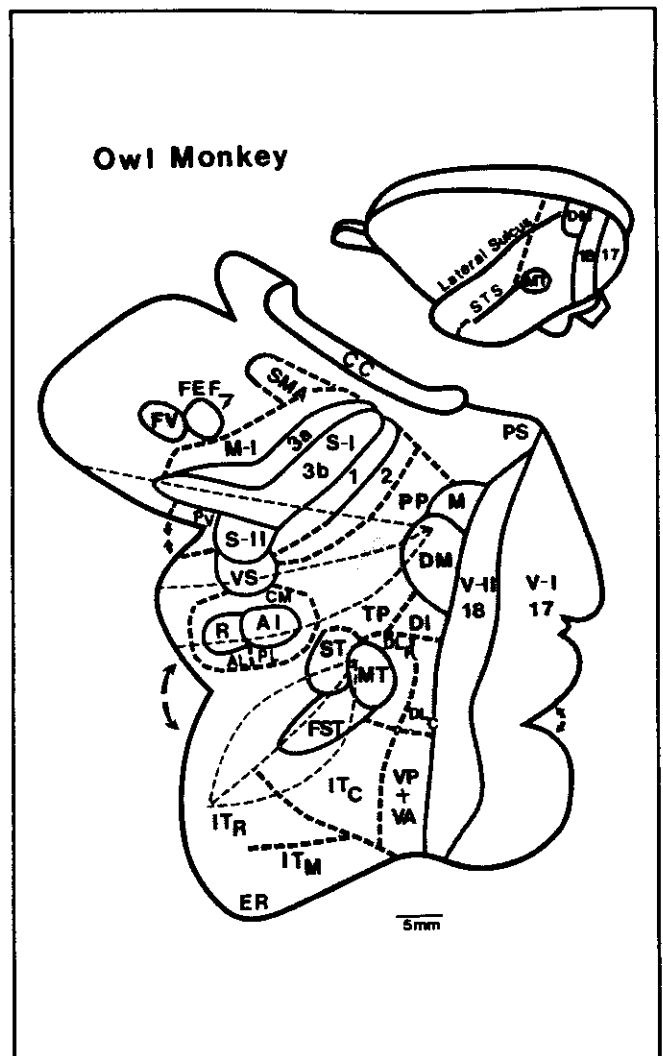

Figure 4. Cortical areas superimposed on an outline of a section from cortex that has been removed, flattened and cut parallel to the surface for a New World owl monkey. A dorsolateral view of the brain with reference areas is on the upper right. The opened lateral (Sylvian) sulcus and superior temporal sulcus (STS) are marked with dashed lines. The corpus callosum (CC) and limbic cortex have been unfolded from the medial wall of the cerebral hemisphere. The visual, somatic, auditory, and motor areas are from published reports on owl monkeys (see Kaas, 1982; 1988 for review and references). A dashed line on the outline of the intact brain (upper right) and the shaded region on the flattened cortex (below) indicates the approximate extent of visual cortex. This includes primary (V-I) and secondary (V-II) fields, the middle temporal visual area (MT), rostral (DL<sub>r</sub>) and caudal (DL<sub>c</sub>) division of the dorsolateral complex, the dorsointermediate area (DI), the dorsomedial area (DM), the medial area (M), the ventroposterior (VP) and ventroanterior (VA) areas, the superior temporal area (ST), the area of the fundus of the superior temporal sulcus (FST), the temporal parietal area (TP), and caudal (IT<sub>c</sub>), rostral (IT<sub>r</sub>) and medial (IT<sub>m</sub>) areas of inferotemporal cortex (IT). Neurons in posterior parietal cortex (PP) are activated by visual stimuli. In addition, the frontal eye field (FEF), the frontal ventral area (FV) and the eye region of the supplementary motor area (SMA) are visual or visuomotor in function. Thus, owl monkeys have on the order of 20 or more visual or visuomotor areas. Somatosensory (3a, S-I or 3b, 1, 2, S-II PV, VS) and auditory (A-I, R, CM, AL, PL) areas have been identified as well. ER, entorhinal cortex.



easily resolved, Marrocco (1986) has critically reviewed the evidence for what he terms "attribute-specific areas" with attribute-specific neurons, and provides guidelines for evaluating visual areas for specificity. Marrocco (1986) concludes that the weight of the evidence is against the theory that neurons in each field are devoted to a single stimulus attribute (as suggested in Figure 7).

#### 4. Why Not Have Just One Big Visual Area?

Reptiles appear to get along with only one visual "area" in dorsal or general cortex (neocortex; see Kaas, 1987b; Ulinski and Mulligan, 1987), with much of the visual processing being done in the optic tectum (superior colliculus) of the midbrain. The optic tectum is extremely well differentiated into layers in some species, but the structure is not subdivided horizontally into a number of areas. Mammals appear to have addressed the problem of increasing visual abilities largely by increasing the number of visual areas, rather than the size of a single field such as V-I. An increase in number rather than just size isn't a result of some unknown factor that limits size. Area 17 varies greatly in size across species, with larger brains having a larger area 17. For example, area 17 can be as much as 1000 times larger in the human than the mouse brain (Figure 6), so areas can be increased greatly in size.

To some extent, some mammals probably do enhance or specialize their visual abilities by enlarging and differentiating an existing visual area or areas. An extreme in specialization where a single visual area is emphasized may be the tarsier, where area 17 is very large, extending over the caudal third of the cerebral hemisphere and more differentiated into layers (and sublayers) than any other mammal (e.g., Hassler, 1966; Woolard, 1925). The large size and sharp laminar distinctions of area 17 in tarsiers are reminiscent of the optic tectum of highly visual birds, and indeed there may be further similarities in function. Tarsiers are specialized as visual predators (Polyak, 1957), and need to be extremely proficient in detecting and tracking prey, but there is little evidence for varied or complex visual behavior.

In a sense, laminar specializations such as that seen in area 17 of tarsiers and the optic tectum of some birds are equivalent to producing more visual areas by stacking representations one on top of the other. The potential of this method of increasing visual abilities is limited, however, by restrictions on the thickness of cortex, which varies only slightly across species.

Another way of creating multiple representations within a single visual area is to have a mosaic of vertical arrays of neurons (local processing modules), with each location in visual space repeated in several types of arrays. Thus, rather than containing a single representation with continuous change across the surface, an area can have repetitions and local discontinuities to produce several fractionated, interdigitated representations, each with its own functions (see Kaas, 1989b). To some extent, all visual areas may multiply functions in this way, but clear

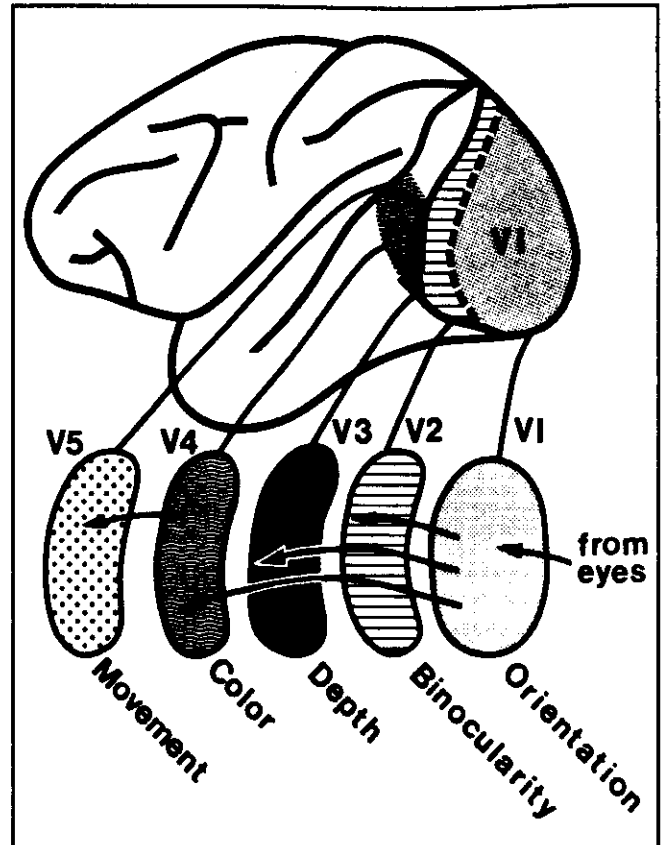

**Figure 7. One concept of serial processing in visual cortex in macaque monkeys. A sequence of visual areas (V-1 - V-5) successively compute and add different features (attributes) of the visual array to result in object vision. The proposal stresses serial processing and the specializations of visual areas for the detection of stimulus attributes, but does not recognize the known complexity of the system. Modified from Young, 1978.**

evidence for distinct classes of modules is available only for area 17 and 18 of monkeys. In area 17, there is evidence for separate laminar systems relating to processing information from the parvocellular and magnocellular geniculate layers, and for separate vertical systems for the cytochrome oxidase (CO) blob and interblob regions, devoted to different aspects of the parvocellular inputs (perhaps stimulus orientation and color, respectively, see Livingstone & Hubel, 1988). In area 18, three types of vertical bands of cells, the M stripe, the P stripe, and the interstripe regions form three fractionated maps of the visual hemifield, each processing a different type of information from area 17 (Figure 9; see Livingstone & Hubel, 1988 for review). In principle, the number of fractionated representations within a single visual area could increase to any number, providing an alternative to increasing the number of separately located and internally coherent visual areas. That the number appears to be small suggests that there are major disadvantages to increasing the number of dispersals of functionally distinct processing modules within a field. The most obvious disadvantage is that as the number increases, interactions between

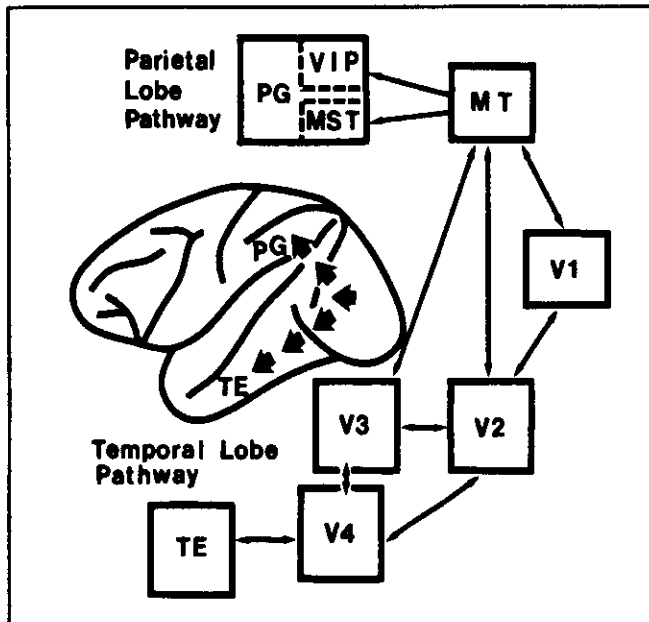

**Figure 8.** A simplified scheme of processing in visual cortex of macaque monkeys stressing two parallel pathways, with the ventral stream for object vision and the dorsal stream to PG (parietal area "G") for visual attention and spatial relations. Modified from Ungerleider (1985). See text and Ungerleider (1985) for details and abbreviations.

modules of the same set and between modules of different sets become dependent on longer connections. Thus, the problem of interconnections within a field may be the major limit on multiplying function within a field (Covey, 1981; Kaas, 1977; see below). Thus, limits on cortical thickness and therefore numbers of functionally distinct layers, and limits on numbers of functionally distinct vertical modules mean that major advances in visual processing cannot result by simply increasing the size of one visual area.

### 5. Concepts of How Multiple Areas are Interconnected

In the classical view of the visual system, there was a simple hierarchy of only two or three functionally distinct subdivisions of cortex (see Merzenich & Kaas, 1980 for review). Thus, a primary "visuosensory" area (area 17 or striate cortex) activated a secondary "visuopsychic" area (Bolton, 1900; Campbell, 1905) divided into two sequential bands, areas 18 and 19 of Brodmann (1909) or the parastriate and peristriate areas of Elliot-Smith (1906). Visuopsychic cortex then fed into bimodal or multimodal association cortex ("interpretive cortex"). Even relatively recent proposals for the organization of visual cortex in humans added to these early views only by allowing several functional subdivisions of interpretive cortex (e.g., Konorski, 1967). For mammals with large numbers of visual areas, these early to more recent views are obviously too simple (see Figures 4 & 5). Yet, the concept of serial processing along a chain of visual areas remains important

in theories of cortical organization (e.g., Hubel & Wiesel, 1965). Another concept, that of parallel processing, has become increasingly discussed in terms of cortical function. More recently, the complexities of cortical processing have been described in terms of a network of interconnected areas. These concepts are discussed and related to current information on the interconnections of visual areas below.

**5a. Serial Processing Across Visual Areas:** Serial processing is certainly an important feature of the visual system. In an overly simple view of visual cortex as a single chain of visual areas, the significance of multiple visual areas is that each area represents a successive step in a serial chain of processing. Such a restricted view of visual processing is no longer common, but it is suggested by some of the terminology in current use. The early and long-standing use of terms such as V-I and V-II, S-I and S-II, and A-I and A-II, implies serial processing (although Woolsey introduced the terms to indicate order of discovery). The subsequent use of the term "V-III" by Hubel and Wiesel (1965) further implies a serial model, although it wasn't clear from the reported data on single neurons that serial processing across fields accomplished much more than the serial processing within V-I (simple to complex to hypercomplex). A chain of processing areas also is implied, intended or not, by the more recent use of the terms V1, V2, V3, V4, V5 and V6 for proposed visual areas (e.g., Zeki, 1978; Figure 7). While Ungerleider and Mishkin (1982) argue for the alignment of visual areas in two parallel streams (see below), only one stream is considered important in the recognition of visual stimuli. According to this view, the areas in the object recognition system are "primarily organized in a serial hierarchy," although parallel processing may occur within a field (Desimone et al., 1985).

**5b. Parallel Processing Across Visual Areas:** Parallel processing streams within visual systems appear to address the problem of the basic slowness of strictly serial systems. Modern views of parallel processing in the mammalian visual system stem from the discoveries that three broad categories of ganglion cells of the retina of cats, the X, Y, and W cells, project in parallel to the lateral geniculate nucleus where the inputs remain largely segregated and project separately to cortex. One hypothesis for cats is that V-I, V-II and V-III, rather than being successive stages in a hierarchy, are three end targets for the parallel pathways, with V-I being devoted to X cells, V-II devoted to Y cells, and V-III devoted to W cells (Stone et al., 1979). In primates, where the W (koniocellular) cell system is typically reduced, and the geniculate projection is almost exclusively restricted to V-I (see Kaas & Huerta, 1988), there is evidence instead for parallel processing of X (parvocellular) and Y (magnocellular) cell information within V-I and V-II (Figure 9, see Kaas, 1986; Livingstone & Hubel, 1988). In addition, Ungerleider and Mishkin (1982) present evidence for a divergence of outflow from V-I into two parallel hierarchies of areas, with one sequence of fields ending in the temporal lobe and



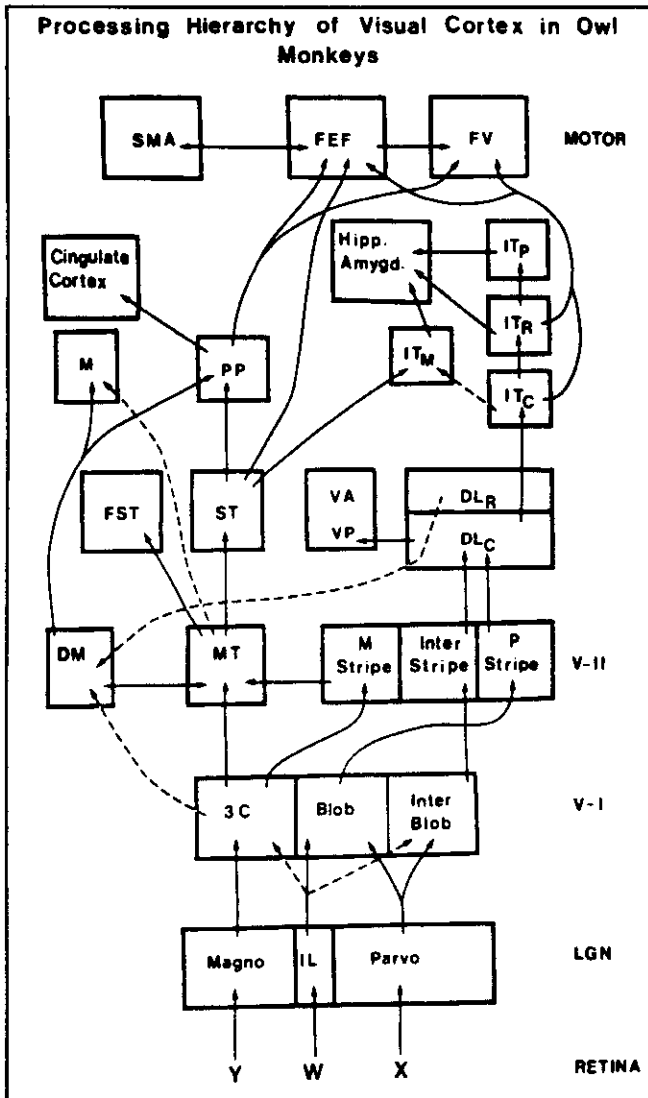

Figure 9. A processing hierarchy for visual areas in owl monkeys. The simplified outline includes major feedforward (see Maunsell and Van Essen, 1983) connections, does not consider all feedback or "intermediate" connections, and does not include all visual areas. Also, the many subcortical and callosal connections are not shown. Serial and parallel processing components are evident. In addition, a given visual area such as MT typically receives inputs from several levels in the system. Thus, higher levels of the sequence may be described by "network" concepts (see text). Functionally distinct classes of cells in the retina (X, Y, and W) project to parvocellular, magnocellular, and interlaminar (IL) regions of the lateral geniculate nucleus (LGN), which in turn project to neurons in V-I that relay to output neurons in layer 3C (Hassler's 1966 terminology), blobs or interblob regions. Subsequent relays are of the magnocellular pathway to the M stripes, and one parvocellular (blob) pathway to the P stripes and the other (interblob) parvocellular pathway to the interstripe regions of V-II (area 18). Layer 3C neurons also project directly to the middle temporal visual area (MT), which also receives an input from the M stripes of V-II. MT projects to cortex in the fundus of the superior temporal sulcus (FST) and the superior temporal area (ST), which relay to posterior parietal cortex as part of a subsystem specialized for visual attention and spatial relations (see Ungerleider and Mishkin, 1982 for details). Most of the output of V-II is directed to the dorsolateral visual area (DL or V-4 of macaque monkeys), where information is relayed over sequence of fields in inferior temporal (IT) cortex (note caudal, c, rostral, r, and polar, p, and medial, m, divisions). Higher levels access cingulate cortex, presumably for motivational components, the hippocampus and amygdala for mechanisms related to the storage of memories, and visuomotor centers (frontal ventral, frontal eye field, supplementary motor area) in the frontal lobe (see Kaas, 1986; 1988 for references and details).

mediating object vision and the other sequence of fields ending in posterior parietal cortex and mediating visual attention and spatial vision (Figure 8). While more elaborate hierarchies have been subsequently proposed (e.g., Figure 9, Ungerleider & Desimone, 1986; Maunsell & Van Essen, 1983; Weller & Kaas, 1987), patterns of connections support the view that many of the visual areas largely belong to one or the other of the two major streams in both New and Old World monkeys. More recent evidence (see Livingstone & Hubel, 1988) suggests that the X (parvocellular) stream subdivides into two parallel streams in V-I, which remain segregated in V-II, and project in parallel to DL (V4) (Figure 9). Thus, at least the early stages of processing in visual cortex of primates are characterized by three parallel streams of sequences of modules connected across several visual areas.

Within the parallel streams in primates, and within the overall hierarchy of visual areas, there are "feedforward" projections from lower to higher levels, and "feedback" projections from higher to lower levels (Maunsell & Van Essen 1983). The feedforward projections presumably

activate the neurons in the higher stations and provide inputs for further computations. The significance of the feedback connections is less certain, but presumably feedback connections modulate the activity of the neurons at the lower level. For areas 17 and 18 of monkeys, the feedback from MT, which is in the Y cell or M stream, distributes across all three processing streams (Krubitzer & Kaas, 1988). Therefore one function of feedback may be to integrate processing across the semi-independent parallel pathways.

**5c. Networks:** A number of models of how neuronal systems function have employed large numbers of simulated neurons that are widely interconnected. Such models may have stages of processing, but they are basically concerned with the outcomes (emergent properties) of multiple interactions at the neuronal level (e.g., Andersen & Zipser, 1988; Hopfield & Tank, 1986; Linsker, 1986). In addition, the term "network" has been used, especially recently, in another way to refer to a collection of cortical areas, presumably functioning together, that are intercon-

nected in a manner that is not obviously hierarchical, or at least in a manner where hierarchical processing across areas is not the dominant feature. For example, Mesulam (1981) and Goldman-Rakic (1988) describe a collection of interconnected fields in the frontal, parietal, and temporal lobes of macaque monkeys as a "network." While feedforward and feedback types of connections clearly exist, many of the connections of visual cortex are of intermediate types that do not clearly identify areas as "higher" or "lower" (see Maunsell & Van Essen, 1983; Weller & Kaas, 1981), supporting the viewpoint that, in some sense, there is validity in describing the organization of visual cortex as a "network" of areas. However, a notion embedded in the concept of a network, whether at the level of neurons or cortical areas, is that widespread interconnections provide widespread accessibility of components to each other (e.g., Hopfield & Tank, 1986). The cortical areas are not so broadly interconnected. If extremely sparse and variable connections are not considered, then cortical areas typically have interconnections with 3-6 fields of the same hemisphere, 2 or 3 fields of the opposite hemisphere, and with 2-3 thalamic nuclei (see Cusick & Kaas, 1986; Merzenich & Kaas, 1980). Only some of these connections have a major activating role, and most of the major connections can be classified as feedforward or feedbackward across series of fields. Thus, the term "network" can be misleading.

**5d. A Manifold System:** Clearly the visual systems of advanced mammals are capable of performing many different functions at once, and include a large number of parts with complex patterns of interconnections. Figure 9 is a greatly oversimplified diagram of how visual cortex is interconnected in owl monkeys. Cortical visual areas are not arranged in a single hierarchy for processing from sensation to perception. Rather, each visual area is interconnected with 3-6 other visual areas with the inclusion of serial, parallel, recurrent, and network-like components. In addition, each visual area directly accesses a number of subcortical regions and receives inputs from parts of the pulvinar complex (see Kaas & Huerta, 1988). In general, current theories of visual system organization and function do not adequately address the complexities of the connectional framework, which suggests that visual processing is manifold in nature (Kaas, 1977), with wide regions of cortex including many cortical fields interacting during even simple visual tasks. Furthermore, the outputs from many visual areas, via subcortical connections, have the potential to directly influence behavior. Perhaps it is the multitude of possible influences on neurons in the motor system that allows the flexibility in behavior that occurs in advanced mammals.

## **6. How Do Connection Patterns Develop and How are They Maintained?**

Obviously what any visual area does, that is the computations that occur in an area, depends on inputs and local

connections. An understanding of the details of connections, how they form and how they are maintained, can contribute to understanding what visual areas do by placing constraints, by making theories more or less likely.

The idea that connections can be guided to very specific and predetermined targets, even over considerable distances, has been with us for some time (e.g., Sperry's chemospecificity theory — see Sperry, 1945). However, the bulk of the evidence now suggests that only the crude outlines of patterns of connections are formed by such guidance. Selection among many possibilities for synaptic targets and synaptic strength provides the details of the connection pattern during development, and maintains and modifies local connections in adults (see Kaas, 1988; Merzenich et al., 1988 for reviews). The critical point of this theory, which has the concept of the "Hebbian" synapse (Hebb, 1949) as its cornerstone, is that synaptic inputs are selected (reinforced) on their ability to be correlated in their activity patterns to the extent that they are active together when the activity is powerful enough to result in the discharging of the target neuron (see Changuex & Danchin, 1976; Willshaw & Von der Malsburg, 1976). If this is the way that the nervous system constructs and maintains itself, then certain connection patterns and therefore modes of functioning seem more likely than others.

Since much of the processing in a sensory system has a hierarchical component, within and across areas, it is instructive to imagine what the selection of inputs with correlated activity would do at successive stages in the visual system. Some of the functional implications of current concepts of the development of connections within and across sensory areas have been reviewed and outlined elsewhere (Kaas, 1988).

One implication is that selection for correlated activity would tend to create and preserve retinotopic and visuotopic organization (see for example, Constantine-Paton, 1982). Obviously, a powerful factor in correlating neural activity is retinal location. Neurons in the same retinal location are likely to fire together, both initially because they are likely to be interrelated by local, perhaps initially random, interconnections, and later in development because they have a high probability of being activated together by the same stimuli. Selection for activity correlated by retinal position would counter the divergences and convergences of potential connections across stations, and retinotopic organization would tend to be preserved across stations. After vision starts, the alignment of the eyes would allow stimuli to activate matched locations in the two eyes, so that in late maturing connections, inputs from the two eyes merge and create visuotopic organization, the systematic representation of visual space.

Another implication is that neurons will become less selective at higher processing levels. Because it is difficult to precisely preserve the timing of neural discharges across multiple relays, each station in the relay will accept, in order to maintain synaptic density, inputs with a greater

range in correlations. One consequence is that the receptive fields get bigger. Thus, whatever functions neurons in higher stations perform, they must do it with larger receptive fields. Neurons in early stations are more likely to be activated by spatially local events, neurons in higher stations are more likely to be activated by more global events. Of course, the amount of selectivity for correlation within a given field may be modifiable in evolution, so that receptive fields for neurons in area 17, for example, may vary in size from species to species, and area 17 may have a role in more global or more local functions accordingly. An advantage of more cortical areas is that this could provide a greater range of levels of local to global processing.

A third implication is that parallel paths will occur and increase in number across higher stations. Location on the receptor sheet is only one way to influence correlations. Another is through neural transductions and computations. The different sensitivities of adjacent receptors dis-correlates the activity of some of the neurons with inputs from the same retinal location and decreases the probability that they will synapse on the same neuron at the next station. This tends to create local populations of neurons that are interconnected and computing on the basis of stimulus properties related to the transduction process, as well as to stimulus location. Post-receptor processing mechanisms, such as those that create the X, Y and W cell classes in the retina, would tend to create parallel pathways across visual areas and semi-isolated processing modules (columns) within areas. Moreover, the construction of any new cell classes (in terms of response properties) at higher stations would tend to increase the number of parallel paths at higher levels in a hierarchy. However, the tendency for an increase in parallel paths would be countered somewhat if higher neurons are more broadly tuned for correlation. Thus, a merging of parallel paths would occur to some extent. Because of a probable relaxation of the correlation requirements, higher areas, by merging streams, would be expected to more closely resemble a broadly interconnected network, and the processing would less closely resemble the predominately hierarchical processing at early levels. Thus, connection patterns between higher areas would be less clearly feedforward or feedback.

If the requirements for correlation become more relaxed across stations, a fourth implication is that feedback connections would be more promiscuous but less effective than feedforward connections. Neurons within a system clearly have synaptic contacts that range in effectiveness. The highly correlated feedforward inputs would acquire the most synaptic strength, and be the most powerful. Because the neurons providing feedback, callosal, and widespread intrinsic connections are less correlated in activity than those providing the feedforward inputs, the feedback, callosal, and widespread intrinsic connections would be less effective and have modulatory roles on neural activity. However, neurons throughout the

visual system seem to be making center-surround or local-global comparisons (see Allman et al., 1985), and the modulatory inputs may be very important in providing the surround or global effects. Providing more global effects is a consequence of broader connections across cell classes and across more visual space as a result of degraded correlations.

## **7. Where in Processing Hierarchies do Visual Areas Get Added?**

All mammals appear to have the primary (area 17 or V-I) and secondary (area 18 or V-II) visual fields (Kaas, 1980) and the end stations of visual processing, such as entorhinal cortex, the amygdala and hippocampus, related to object identification and visual memories (Mishkin, 1982), the medial limbic cortex, related to visual attention and motivation (Mesulam, 1981), and the motor and visuomotor fields and subcortical structures mediating motor behavior. The simple hierarchies of visual areas, with little more than beginning and end stations, that characterize the brains of mice and hedgehogs become complex hierarchies, like those of monkeys and cats, by the addition of new visual areas in the middle stages of processing. As a result, a change occurs from the situation where the first cortical station, area 17, directly accesses some of the end or near end cortical stations in frontal and limbic cortex, as in rats and mice (e.g., Miller & Vogt, 1984), to where area 17 relates to only early stages of a lengthy hierarchy, as in monkeys (Figure 6).

## **8. Theories of Why Multiple Visual Areas Exist**

Several proposals have been made for the advantages provided by having larger rather than smaller numbers of areas in visual cortex. The proposals, to some extent, address different issues, and are, to a large extent, mutually compatible. The first proposals are different versions of the basic theme that visual areas are specialized for analyzing different aspects of the visual world, and that having more visual area allows the analysis of more aspects.

### **8a. Increasing the Number of Visual Areas Increases the Number of Visual Abilities:**

This widespread assumption seems valid, though poorly supported. Clearly there is an overall relationship between the magnitude of brain development and abilities. To consider extremes, the visual capabilities of some fish seem to be so limited that they select prey on the basis of retinal image size (see Wetterer & Bishop, 1985) rather than real size (which can be determined only with information in addition to image size), while human vision includes complex and varied inferences about the visual world that allow, for example, mental rotations of objects, accurate predictions about where obscured moving objects will appear, and the rapid identification (categorization) of a wide range of objects. By being less extreme and considering only mammals, no doubt mammals with few visual areas, such as hedgehogs and mice, have visual capacities vastly inferior to those of

mammals with many visual areas, such as cats, monkeys, and presumably humans. Of course there are several nagging concerns. Mammals with more visual areas also have larger brains (relative to body size), and it's not certain that number of areas rather than brain size is important. There probably is an interaction, but it would be difficult to evaluate the relative contributions of brain size and number of fields. Another problem is that studies of animal behavior have concentrated on species with simple nervous systems, and we do not have a comprehensive understanding of how visual abilities vary in mammals. Finally, we have an understanding of the broad outlines of cortical organization and these outlines are available for only a few species. Presently, we can't be precise about the number of visual areas for any species. For these reasons, it is unlikely that we will have strong evidence in the near future for the assumption that increases in numbers of areas leads to increased abilities.

Opinions differ on how having more visual areas increases visual abilities. A common view is that visual information is distributed to a number of visual areas where each visual area processes different "attributes" (contrast, spatial frequency, orientation, movement, retinal disparity, size, color) of a complex visual stimulus (Covey, 1979; Young, 1978; Zeki, 1978). According to Zeki (1974; 1978), for example, multiple visual areas are for the "division of labor" and "simultaneous analysis" of different components of vision. Different functions are emphasized in different cortical areas. More specifically according to this view, V1 emphasizes the analysis of stimulus contours, V2 relates to depth, V4 (DL) is devoted to color, and V5 (MT) is critical for detecting movement. However, most mammals, including some with the fewest visual areas, are sensitive to these basic attributes of visual stimuli. Thus, species differences in numbers of areas are not explained, unless one holds that other (unspecified) stimulus features are analysed by advanced but not by primitive mammals.

Another approach is to be less specific about what identified visual areas do, but simply propose that having more visual areas allows more stimulus parameters to be considered. Thus, Ballard (1986) concludes that neurons within any field have "multimodal" responses, but the number of parameters that can be handled by any topographic representation is limited (on the order of 5–15). Given that it is beneficial to compute a large number of parameters, multiple areas are needed. A related concept is that multiple visual areas allow the system to detect "suspicious coincidences" along more stimulus parameters. According to Barlow (1986), the primary and other areas distribute information to a number of visual areas, each organized to detect different "suspicious coincidences" or "linking factors" (e.g., attributes such as orientation, direction of motion, or color) of the stimulus (also see Phillips et al., 1984). Topographic representations preserve neighborhood relations, and therefore are useful in detecting coincidences in restricted regions of

visual space. However, associations that do not depend on proximity in space are psychologically important, and non-topographic maps or transformations, according to Barlow, would seem better suited for most detections. Somewhat differently, Desimone et al. (1985), argue that object vision depends on the flow of information along a pathway from striate cortex to the temporal lobe, where processing is serial, yet multi-dimensional and increasingly abstract at each stage. According to this view, having more, rather than fewer, visual areas would allow more complex processing that would enrich perception and reduce perceptual errors.

Multiple areas also provide more links to motor outputs. Each visual area projects to approximately 5–15 subcortical structures and nuclei (e.g., Graham et al., 1979), and many of these structures are closely related to motor performance. Most of these structures have inputs from a number of visual areas, although the pattern of subcortical targets is different for each visual area. Creutzfeldt (1985) has emphasized that there may be behavioral advantages to having such multiple links between the sensory organ and the motor output. One possible advantage may be that more possible influences on motor outputs increases behavioral flexibility.

### **8b. Multiple Areas Simplify the Problem of Interconnecting Functionally Related Groups of Neurons:**

Covey (1979; 1981), and others (i.e., Barlow, 1986; Kaas, 1977) have argued that having multiple visual areas is an effective way of allowing neurons to have the connections needed for their roles in perception. Covey (1979) starts with the premise that the different visual areas are concerned with "different aspects of the visual world" (attributes). Most areas have retinotopic maps because the interactions between neurons with similarly located receptive fields that create selectivity for specific attributes of a complex stimulus depend on connections that are best short and local and would be "cumbersome or impossible" if long. Covey (1979) also supposes that it is genetically easier to program local rather than far-reaching connections. Thus, within visual areas "the retina is topographically mapped in order to keep intracortical connections short and to simplify developmental specificity." Multiple visual areas exist "for the same reasons." More specifically, the local connections that would be needed to sharpen the tuning of individual neurons for one of the many attributes (see above) of a complex stimulus would be long if neurons for all the different attributes were in the same visual area. Having many retinotopic maps allows most of the computing to be done with short local connections, although the receiving and sending information would require long connections between areas and subcortical structures. Most visual areas are semiretinotopic; that is, at the global level there is a retinotopic map, but locally other features of organization dominate. In the development of the brain, crude guidance could set up the long connections that interrelate these separate maps, and the order of

these connections, including aspects important for retinotopic and local features, could be refined by rules for reinforcing correlated activity (see above). Neurons in these visual areas seem to be connected in ways that allow comparisons between more local and more global features of the stimulus (see Allman et al., 1985). Connections that allow such computations would be long and widespread if visual functions were expanded by enlarging a single visual area. In the largest visual area, V-1, some of the intrinsic connections are very long, up to 5–6 mm in some mammals, and widespread, yet they interrelate neurons that are typically concerned with only 10° or so of visual space, and in monkeys, at least, involve only a limited subset of neurons. To widely interconnect neurons, and to have many different types of neurons with different connection patterns within a single field, would seem to require an unreasonable amount of genetic programming.

**8c. Adding Visual Areas Overcomes Constraints on Modifying Existing Visual Systems that are Imposed by the Ongoing Needs of the Individuals and Allows New Capacities to Evolve:** Allman and Kaas (1971; 1974) have discussed the possible significance of multiple visual areas in the general context of evolution. Existing body plans clearly have constraints on change that may be difficult or impossible to overcome. For example, we can presume that most vertebrates have not evolved human-like hands or bird-like wings because the forelimbs are part of the basic walking and support system, and it is difficult to gradually, over many generations, switch from an effective four-legged system to an effective two-legged system. Perhaps hands and wings would have become much more common if it were possible to add pairs of limbs to the basic four in vertebrates. However, the replication of existing parts has been common in evolution (see Gregory, 1935), and the number of visual areas has increased in several lines of evolution, possibly by the replication of existing areas or (and) by the subdivision of existing areas (see Kaas, 1986). Existing visual areas in any species presumably are performing functions critical to the existence of that species, and therefore only limited changes in organization may be compatible with current requirements for ongoing functions basic for survival and reproduction. Large scale changes that may seem logical in terms of body design may just not be possible due to impaired function during the period of change. The creation of new visual areas allows this constraint to be avoided. If a genetic mutation occurs that results in the replication of an existing cortical area, either area would be capable of performing the functions of the old area, and the new area or the old area could be modified gradually for new functions, or the two areas could divide old functions between them and each modify for new functions.

### Acknowledgments

This manuscript is based on an invited presentation given at the 3rd Annual Meeting of the American Academy of Clinical Neurology. I thank R. Blake, J. Bullier, P. Garraghty, S. Florence, L. Krubitzer, and M. Powers for comments on the manuscript.

### References

- Allman, J. M., Meizin, F., & McGuinness, E. (1985). Stimulus specific responses from beyond the classical receptive field: Neurophysiological mechanisms for local-global comparisons in visual neurons. *Annual Review of Neuroscience*, 8, 407–430.
- Allman, J. M., & Kaas, J. H. (1971). A representation of the visual field in the posterior third of the middle temporal gyrus of the owl monkey (*Aotus trivirgatus*). *Brain Research*, 31, 85–105.
- Allman, J. M., & Kaas, J. H. (1974). A crescent-shaped cortical visual area surrounding the middle temporal area (MT) in the owl monkey (*Aotus trivirgatus*). *Brain Research*, 81, 199–213.
- Allman, J. M., Baker, J. F., Newsome, W. T., & Peterson, S. E. (1981). Visual topography and function: Cortical areas in the owl monkey. In C. N. Woolsey (Ed.), *Cortical Sensory Organization, Vol. 2: Multiple Visual Areas* (pp.17–185). Clifton, N. J.: Humana Press.
- Andersen, D. A., & Zipser, D. (1988). The role of the posterior parietal cortex in coordinate transformations for visual-motor integration. *Canadian Journal of Physiology and Pharmacology*, 66, 488–501.
- Baker, J. F., Peterson, S. E., Newsome, W. T., & Allman, J. M. (1981). Response properties in four extrastriate visual areas of the owl monkey (*Aotus trivirgatus*): A quantitative comparison of medial, dorsomedial, dorsolateral, and middle temporal areas. *Journal of Neurophysiology* 45, 397–416.
- Ballard, D. H. (1986). Cortical connections and parallel processing: Structure and function. *The Behavioral and Brain Sciences*, 9, 67–120.
- Ballard, D. H. (1987). Cortical connections and parallel processing: Structure and function. In M. A. Arbib and A. R. Hanson, (Eds), *Vision, Brain, and Cooperative Computation* (pp. 563–621). Cambridge, Massachusetts: MIT Press.
- Barlow, H. B. (1972). Single units and sensation: A neuron doctrine for perceptual psychology. *Perception*, 1, 371–394.
- Barlow, H. B. (1985). Cerebral cortex as model builder. In D. Rose and V. G. Robson (Eds.), *Models of the Visual Cortex* (pp. 37–46). New York: John Wiley and Sons.
- Barlow, H. B. (1986). Why have multiple cortical areas? *Vision Research*, 26, 81–90.
- Bolton, J. S. (1900). On the exact histological localization of the visual area of the human cerebral cortex. *Philosophical Transactions*, 193, 165–222.
- Brodmann, K. (1909). *Vergleichende Lokalisationslehre der Grosshirnrinde*, Barth: Leipzig.
- Campbell, A. W. (1905). *Histological Studies on the Localization of Cerebral Function*. Cambridge: University Press.

- Changeux, J. P., & Danchin, A. (1976). Selective stabilization of developing synapses as a mechanism for the specification of neuronal networks. *Nature*, 264, 705–712.
- Constantine-Paton, M. (1982). The retinotectal hookup: The process of neural mapping. In S. Subtelny (Ed.), *Developmental Order: Its Origin and regulation* (pp. 317–349). New York: Liss.
- Cowey, A. (1979). Cortical maps and visual perception. The Grindley Memorial Lecture. *Quarterly Journal of Experimental Psychology*, 31, 1–17.
- Cowey, A. (1981). Why are there so many visual areas? In F. O. Schmitt, F. G. Warden, G. Adelman, & S. G. Dennis (Eds.), *The Organization of the Cerebral Cortex* (pp. 395–413). Cambridge, Massachusetts: MIT Press.
- Creutzfeldt, O. (1985). Multiple visual areas: Multiple sensorimotor links. In D. Rose & V. G. Dobson (Eds.), *Models of the Visual Cortex* (pp. 54–61). New York: John Wiley and Sons.
- Creutzfeldt, O. (1986). Comparative aspects of representation in the visual system. In C. Chagas & R. Gattas (Eds.), *Experimental Brain Research Supplement*, 11, 53–82.
- Cusick, C. G. & Kaas, J. H. (1986). Interhemispheric connections of cortical, sensory and motor maps in primates. In F. Lepore, M. Ptito, & H. H. Jasper (Eds.), *Two Hemispheres—One Brain* (pp. 83–102). New York: Alan R. Liss, Inc.
- Cusick, C. G. & Kaas, J. H. (1988). Cortical connections of area 18 and dorsolateral visual cortex in squirrel monkeys. *Visual Neuroscience*, 1, 211–237.
- Desimone, R., & Ungerleider, L. G. (1986). Multiple visual areas in the caudal superior temporal sulcus of the macaque. *Journal of Comparative Neurology*, 248, 164–189.
- Desimone, R., Schein, S. J., Moran, J., & Ungerleider, L. G. (1985). Contour, color and shape analysis beyond the striate cortex. *Vision Research*, 25, 441–452.
- DeYoe, E. A., & Van Essen, D. C. (1985). Segregation of efferent connections and receptive field properties in visual area V2 of the macaque. *Nature*, 317, 58–61.
- DeYoe, E. A., & Van Essen, D. C. (1988). Concurrent processing streams in monkey visual cortex. *Trends in Neuroscience*, 11, 219–226.
- Economo, von C. (1929). *The Cytoarchitectonics of the Human Cortex*. Oxford: Oxford University Press.
- Elliot-Smith, G. E. (1906). A new topographic survey of human cerebral cortex, being an account of the distribution of the anatomically distinct cortical areas and their relationship to the cerebral sulci. *Journal of Anatomy and Physiology*, 41, 27–254.
- Goldman-Rakic, P. S. (1988). Topography of cognition: Parallel distributed networks in primate association cortex. *Annual Review of Neuroscience*, 11, 137–156.
- Graham, J., Lin, C. S., & Kaas, J. H. (1979). Subcortical projections of six visual cortical areas in the owl monkey, *Aotus trivirgatus*. *Journal of Comparative Neurology*, 187, 557–580.
- Gregory, W. K. (1935). Reduplication in evolution. *Quarterly Review of Biology*, 10, 272–290.
- Gross, C. G., Rocha-Miranda, C. E., & Bender, D. B. (1972). Visual properties of neurons in inferotemporal cortex. *Journal of Neurophysiology*, 35, 96–111.
- Hassler, R. (1966). Comparative anatomy of the central visual systems in day- and night-active primates. In R. Hassler & H. Stephan (Eds.), *Evolution of the Forebrain* (pp. 419–434). Stuttgart: Thieme Verlag.
- Hebb, P. O. (1949). *Organization of Behavior*. New York: John Wiley and Sons.
- Hopfield, J. J., & Tank, D. W. (1986). Computing with neural circuits: A model. *Science*, 233, 625–633.
- Hubel, D. H., & Wiesel, T. N. (1965). Receptive fields and functional architecture in two non-striate visual areas (18 and 19) of the cat. *Journal of Neurophysiology*, 28, 229–289.
- Kaas, J. H. (1977). Sensory systems in mammals. In G. S. Stent (Ed.), *Function and Formation of Neural Systems* (pp. 65–80). Berlin: Drahlem Konferehenzen.
- Kaas, J. H. (1980). A comparative survey of visual cortex organization in mammals. In S. O. E. Ebbesson (Ed.), *Comparative Neurology of the Telencephalon* (pp. 483–502). New York: Plenum Press.
- Kaas, J. H. (1982). The segregation of function in the nervous system: Why do sensory systems have so many subdivisions? In W. P. Neff (Ed.), *Contributions to Sensory Physiology* (vol.7, pp. 201–240). New York: Academic Press.
- Kaas, J. H. (1986). The structural basis for information processing in the primate visual system. In J. D. Pettigrew, W. R. Levick, & K. J. Sanderson (Eds.), *Visual Neuroscience* (pp. 315–340). Cambridge: Cambridge University Press.
- Kaas, J. H. (1987a). The organization of neocortex in mammals: Implications for theories of brain function. *Annual Review of Psychology*, 38, 124–151.
- Kaas, J. H. (1987b). The organization and evolution of neocortex. In S. P. Wise (Ed.), *Higher Brain Functions* (pp. 347–378). New York: John Wiley and Sons.
- Kaas, J. H. (1988). Development of cortical sensory maps. In P. Rakic & W. Singer (Eds.), *Neurobiology of Neocortex* (pp. 41–67). New York: Springer Verlag.
- Kaas, J. H. (1989a). Changing concepts of visual cortex organization of primates. In J. W. Brown (Ed.), *Neurobiology of Visual Perception*. Hillsdale, New Jersey: Lawrence Erlbaum Associates.
- Kaas, J. H. (1989b). Processing modules in sensory-perceptual cortex. In *Signal and Sense: Local and Global Order in Perceptual Maps*, in press.
- Kaas, J. H. & Huerta, M. F. (1988). Subcortical visual system of primates. In H. P. Steklis (Ed.), *Comparative Primate Biology, Vol. 4: Neurosciences* (pp. 327–391). New York: Alan R. Liss, Inc.
- Kaas, J. H., Krubitzer, L. A., & Johanson, K. L. (1989). Cortical connections of areas 17 (V-I) and 18 (V-II) of squirrels. *Journal of Comparative Neurology*, in press.
- Konorski, J. (1967). *Integrative Activity of the Brain*. Chicago: University of Chicago Press.

- Krubitzer, L. A., & Kaas, J. H. (1988). Cortical integration of parallel pathways in the visual system of primates. *Brain Research*, in press.
- Krubitzer, L. A., Sesma, M. A., & Kaas, J. H. (1986). Microelectrode maps, myeloarchitecture, and cortical connections of three somatotopically organized representations of the body surface in parietal cortex of squirrels. *Journal of Comparative Neurology*, *253*, 415–434.
- Lashley, K. S. & Clark, G. (1946). The cytoarchitecture of the cerebral cortex of Ateles: A critical examination of architectonic studies. *Journal of Comparative Neurology*, *85*, 223–305.
- Linsker, R. (1986). From basic network principles to neural architecture: Emergence of spatial-opponent cells. *Proceedings of the National Academy of Sciences, USA*, *83*, 7508–7512.
- Livingstone, M. S., & Hubel, D. H. (1988). Segregation of form, color, movement, and depth: Anatomy, physiology, and perception. *Science*, *240*, 740–749.
- Luethke, L. E., Krubitzer, L. A., & Kaas, J. H. (1988). Cortical connections of electrophysiologically and architectonically defined subdivisions of auditory cortex in squirrels. *Journal of Comparative Neurology*, *268*, 181–203.
- Marrocco, R. T. (1986). The neurobiology of perception. In J. E. LeDoux & W. Hirst, (Eds.), *Mind and Brain, Dialogues in Cognitive Neuroscience* (pp. 33–79). Cambridge: Cambridge University Press.
- Maunsell, J. H. R., & Newsome, W. T. (1987). Visual processing in monkey extrastriate cortex. *Annual Review of Neuroscience*, *10*, 363–401.
- Maunsell, J. H. R., & Van Essen, D. C. (1983). The connections of the middle temporal visual area (MT) and their relationship to a cortical hierarchy in the macaque monkey. *Journal of Neuroscience*, *12*, 2563–2586.
- Merzenich, M. M., & Kaas, J. H. (1980). Principles of organization of sensory-perceptual systems in mammals. In J. M. Sprague and A. N. Epstein (Eds.), *Progress in Psychobiology and Physiological Psychology* (pp. 1–42). New York: Academic Press.
- Merzenich, M. M., Recanzone, G., Jenkins, W. M., Allard, P. T., Nudo, R. J. (1988). Cortical representational plasticity. In P. Rakic & W. Singer (Eds.), *Neurobiology of Neocortex* (pp. 41–67). New York: Springer Verlag.
- Mesulam, M. M. (1981). A cortical network for directed attention and unilateral neglect. *Annals of Neurology*, *10*, 309–325.
- Miller, M. W., & Vogt, B. A. (1984). Direct connections of rat visual cortex with sensory, motor, and association cortices. *Journal of Comparative Neurology*, *226*, 184–202.
- Mishkin, M. (1982). A memory system in the monkey. *Philosophical Transactions of the Royal Society of London [Biology]*, *248*, 85–95.
- Montero, V. M., Rojas, A., & Torrealba, F. (1973). Retinotopic organization of striate and peristriate visual cortex in the albino rat. *Brain Research*, *53*, 197–201.
- Optican, L. M., & Richmond, B. J. (1987). Temporal encoding of two-dimensional patterns by single units in primate inferior temporal cortex. III. Information theoretic analysis. *Journal of Neurophysiology*, *57*, 162–178.
- Phillips, C. G., Zeki, S., & Barlow, H. B. (1984). Localization of function in the cerebral cortex: Past, present and future. *Brain*, *107*, 327–361.
- Polyak, S. (1957). *The Vertebrate Visual System*. Chicago: University of Chicago Press.
- Shipp, S., & Zeki, S. (1985). Segregation of pathways leading from area V2 to areas V4 and V5 of macaque monkey visual cortex. *Nature*, *315*, 322–325.
- Sperry, R. (1945). Chemoaffinity in the orderly growth of nerve fiber patterns and connections. *Proceedings of the National Academy of Sciences, USA*, *50*, 703–710.
- Stensaas, S. S., Eddington, D. K., & Dobbelle, W. H. (1979). The topography and variability of the primary visual cortex in man. *Journal of Neurosurgery*, *40*, 747–755.
- Stone, J., Dreher, B., & Leventhal, A. (1979). Hierarchical and parallel mechanisms in the organization of visual cortex. *Brain Research Reviews*, *1*, 345–394.
- Treisman, A., & Gormican, S. (1988). Feature analysis in early vision: Evidence from search asymmetries. *Psychological Review*, *95*, 15–48.
- Uliniski, P. S., & Mulligan, K. A. (1987). Representation of visual space in the visual cortex of turtles. *Society of Neuroscience Abstracts*, *13*, 1048.
- Ungerleider, L. A. (1985). The corticocortical pathways for object recognition and spatial perception. In C. Chagas, R. Gattass, and C. Gross (Eds.), *Pattern Recognition Mechanisms. The Pontifical Academy of Sciences*, 21–37.
- Ungerleider, L. A. & Desimone, R. (1986). Cortical connections of visual area MT in the Macaque. *Journal of Comparative Neurology*, *248*, 190–222.
- Ungerleider, L. G., & Mishkin, M. (1982). Two cortical visual systems. In D. J. Ingle, M. A. Goodale, and R. J. W. Mansfield (Eds.), *Analysis of Visual Behavior* (pp. 549–586). Cambridge, MA: MIT Press.
- Van Essen, D. C. (1985). Functional organization of primate visual cortex. In A. Peters, & E. G. Jones (Eds.), *Cerebral Cortex, Vol. 3* (pp. 259–329). New York: Plenum Press.
- Van Essen, D. C., Newsome, W. T., & Maunsell, J. H. R. (1984). The visual field representation in striate cortex of the macaque monkey: Asymmetries, anisotropies, and individual variability. *Vision Research*, *24*, 429–448.
- Wagor, E., Mangini, N. J., Pearlman, A. L. (1980). Retinotopic organization of striate and extrastriate visual cortex in the mouse. *Journal of Comparative Neurology*, *193*, 187–202.
- Weller, R. E., & Kaas, J. H. (1981). Cortical and subcortical connections of visual cortex in primates. In C. N. Woolsey (Ed.), *Cortical Sensory Organization, Vol. 2: Multiple Visual Areas* (pp. 121–155). Clifton, NJ: Humana Press.
- Weller, R. E., & Kaas, J. H. (1981). Subdivisions of connections

of inferior temporal cortex in owl monkey. *Journal of Comparative Neurology*, 256, 137-172.

Wetterer, J. K., & Bishop, C. J. (1985). Planktivore prey selection: The reactive field volume model vs. the apparent size model. *Ecology*, 66, 457-464.

Willshaw, D. J., & Von der Malsburg, C. (1976). How patterned neural connections can be set up by self-organization. *Proceedings of the Royal Society of London, Series B.*, 194, 431-445.

Woolard, H. H. (1925). The cortical lamination of Tarsius. *Journal of Anatomy*, 60, 86-105.

Young, J. Z. (1978). *Programs of the brain*. Oxford: Oxford University Press.

Zeki, S. M. (1974). The mosaic organization of the visual cortex in the monkey. In R. Bellairs & E. G. Gray (Eds.), *Essays on the Nervous System — A Festschrift for Professor J. Z. Young* (pp.327-343). Oxford: Clarendon Press.

Zeki, S. M. (1978). Functional specialization in the visual cortex of the rhesus monkey. *Nature*, 274, 423-438.