



the  
**abdus salam**  
international centre for theoretical physics

ICTP 40th Anniversary

*SCHOOL ON SYNCHROTRON RADIATION AND APPLICATIONS*  
*In memory of J.C. Fuggle & L. Fonda*

19 April - 21 May 2004

*Miramare - Trieste, Italy*

1561/25

---

**SAXS under extreme conditions**

**H. Amenitsch**

# SAXS Under Extreme Conditions

H.Amenitsch

## Outline:

### -Why?

What is extreme?

Scientific case

How it all began?

### -How to trigger transitions?

Jump-relaxation methods

Other (oscillatory) methods

### -Applications

Biology and Biomedicine

Physical Chemistry

Material Science

### -Outlook



AUSTRIAN SAXS - BEAMLINE AT ELETTRA

H. Amenitsch, S. Bernstorff, P. Dubcek, M. Rappolt & P. Laggner



## Why?

### What is extreme?

- Temperature: mK,  $10^3$  K,  $10^6$  K
- Time scales: years, s, ms,  $\mu$ s
- Pressure: MPa, GPa
- Chemical potential
- Non equilibrium states => Transitions

### Scientific Case:

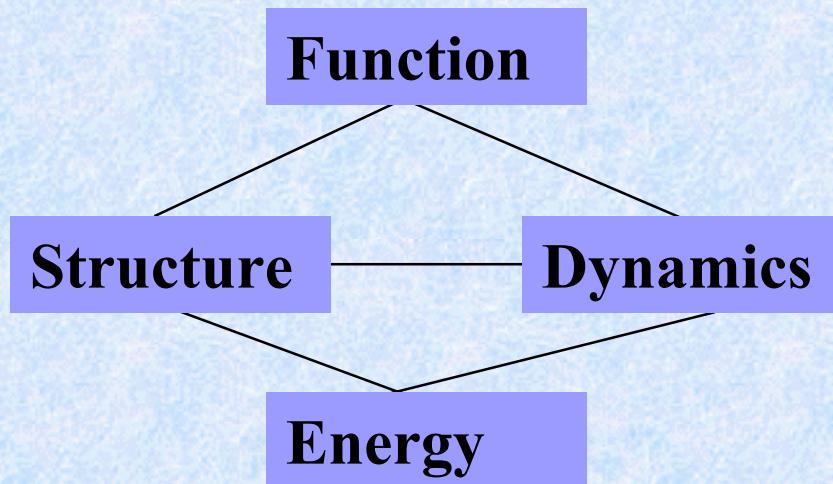

#### Biology and Biomedicine:

- understand molecular and cellular function
- find ways to cure diseases

#### Material Science:

- understand macro- and supramolecular assembly
- find new, purpose-designed materials



AUSTRIAN SAXS - BEAMLINe AT ELETTRA

H. Amenitsch, S. Bernstorff, P. Dubcek, M. Rappolt & P. Laggner



# Why? - How it all began - Muscle Contraction

September 1970: DESY  
 Rosenbaum, Holmes & Witz, Nature (1971), 230,434

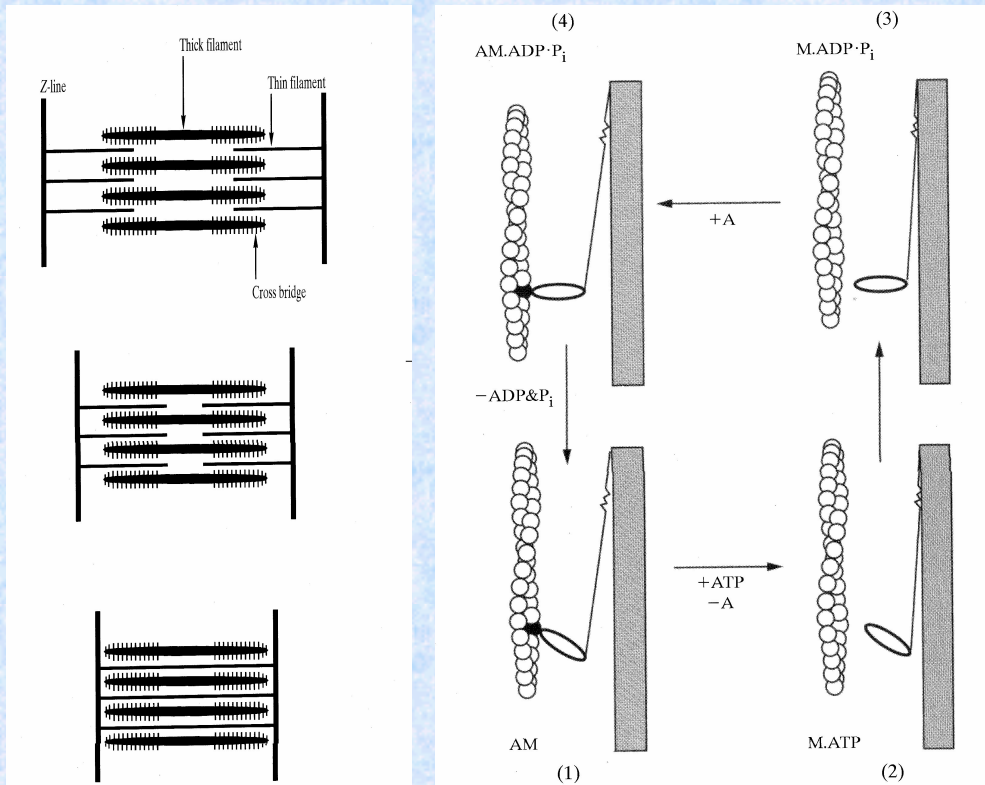

Fig. Muscle Contraction thick (myosin)-, thin-(actin) fibers are interdigitating  
 K.C Holms Acta Cryst. A54, (1997), 789

Fig. Lymn-Taylor cycle. (Lymn, Taylor Biochemistry, (1971)10, 4617 Myosin-cross-bridge is bound in rigor (1) ATP binds->quick dissociation (2) ATP->ADP + P (hydrolysis) binding of myosin to actin 90 up (3) release of components, rowing to (1)

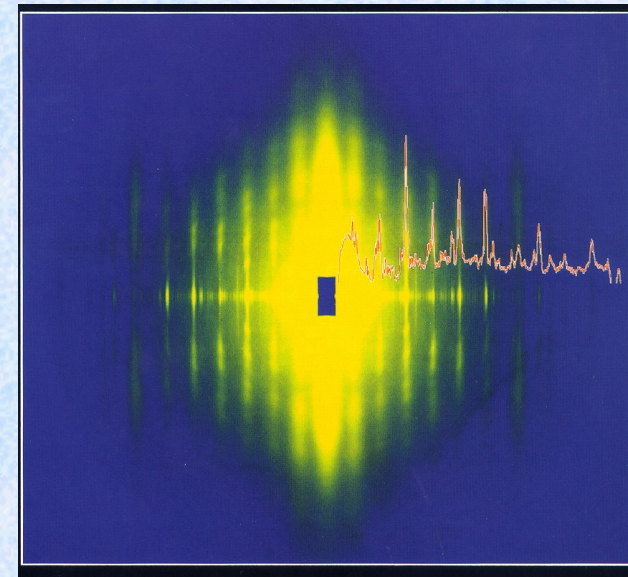

Fig. Diffraction pattern of life skeletal frog muscle Cover page: Yagi, et.al. J.Synchrotron. Rad (1996), 3,247



AUSTRIAN SAXS - BEAMLINE AT ELETTRA

H. Amenitsch, S. Bernstorff, P. Dubcek, M. Rappolt & P. Laggner



# Why? - How it all began - Muscle Contraction

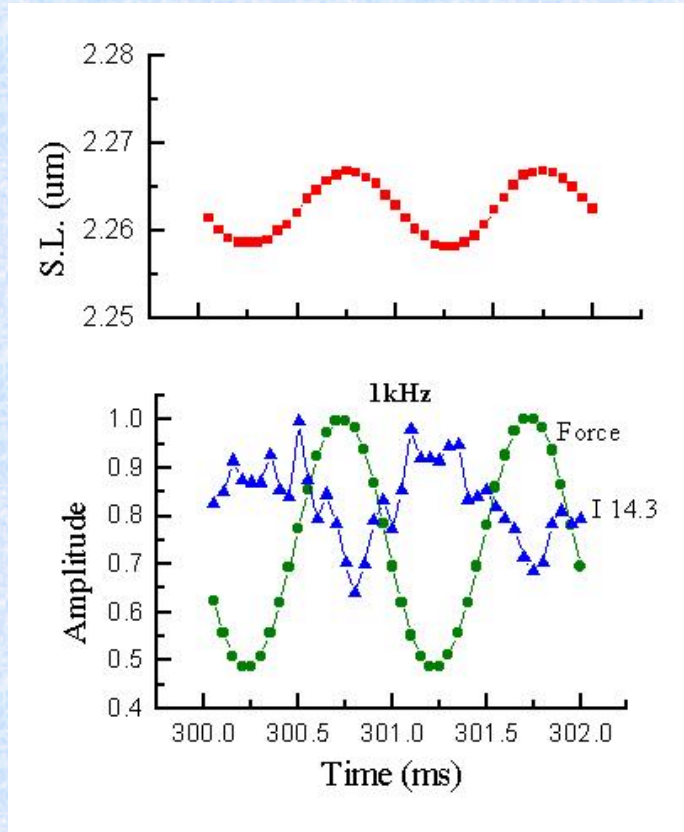

Fig.: Sarcomere length (S.L., filled squares), force (filled circles) and IM3 (I14.3, filled triangles) for a single fibre undergoing 1 kHz sinusoidal length oscillations

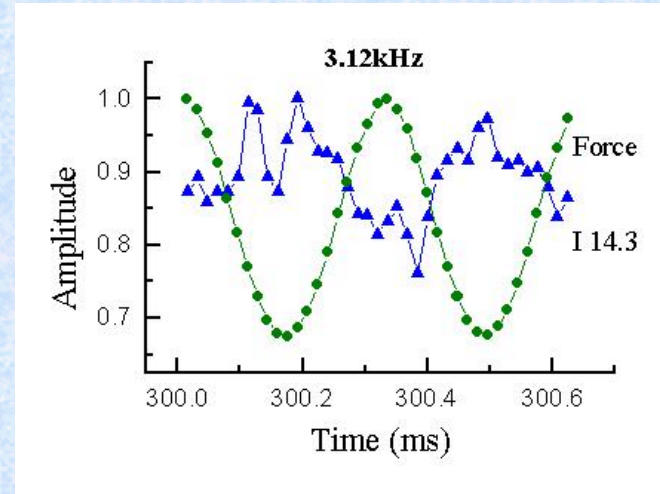

Fig.: IM3 (I14.3, filled triangles) and force (filled circles) for a two fibre bundle undergoing 3.12 kHz sinusoidal length oscillations. Sampling time 16 micro-seconds.

Literature:

Bagni MA, et.al., BIOPHYSICAL JOURNAL **80**, 2809, (2001)

Piazzesi G, et.al. NATURE **415**, 659, (2002)

H. Amenitsch, C.C. Ashley, M.A. Bagni, S. Bernstorff, G. Cecchi, B. Colombini and P.J. Griffiths, Elettra News Letter, Number 26 (1), August 31, 1998



AUSTRIAN SAXS - BEAMLINe AT ELETTRA

H. Amenitsch, S. Bernstorff, P. Dubcek, M. Rappolt & P. Laggner



## How to trigger transitions?

-T-jump (heating): Erbium Glass Laser

“heat exchanger”

-T-cool jump: “heat exchanger”

-p scans: High pressure cells  
hydrostatic pressure  
diamond anvil cells

-p-jumps

-Stopped-flow cells: -M.C.Ramachandra et.al. Biophysical Journal **74**, (1998), 2714

-Segel DJ, Bachmann A, Hofrichter J, Hodgson KO, Doniach S, Kiefhaber T, JOURNAL OF MOLECULAR BIOLOGY, 288, 489, (1999)

-Pollack L, Tate MW, Darnton NC, Knight JB, Gruner SM, Eaton WA, Austin RH, PNAS, 96,10115, (1999)

-Batch reactor

-Magnetic field

-Shear experiments



**AUSTRIAN SAXS - BEAMLINE AT ELETTRA**

H. Amenitsch, S. Bernstorff, P. Dubcek, M. Rappolt & P. Laggner



# SAXS - Applications: T-jump Device

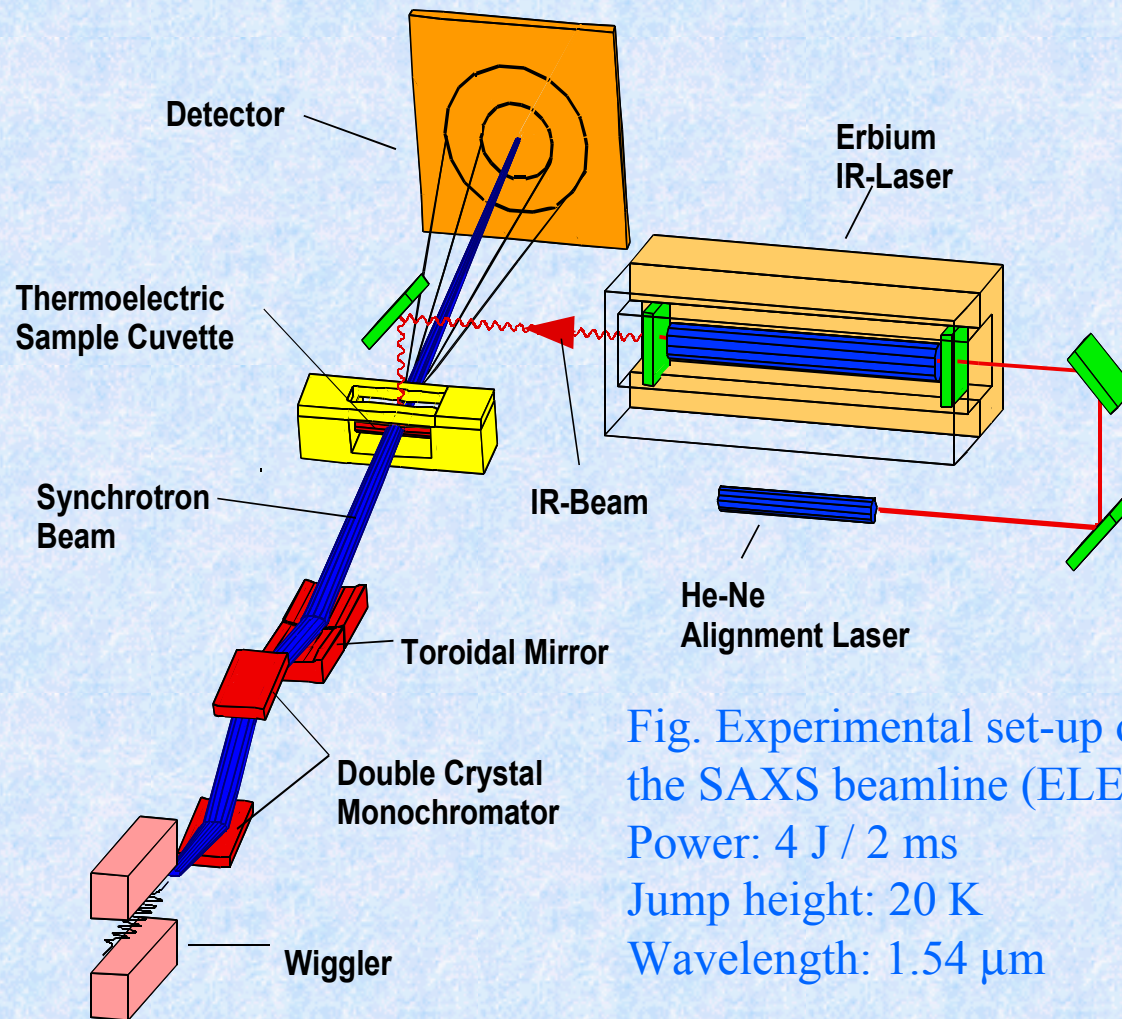

Fig. Experimental set-up of the T-jump device at the SAXS beamline (ELETTRA).

Power: 4 J / 2 ms

Jump height: 20 K

Wavelength: 1.54  $\mu\text{m}$



AUSTRIAN SAXS - BEAMLINE AT ELETTRA

H. Amenitsch, S. Bernstorff, P. Dubcek, M. Rappolt & P. Laggner



# T-jump on Low Density Lipoprotein

## 10 ms time-resolved x-ray diffraction of the core lipid transition of human Low Density Lipoproteins

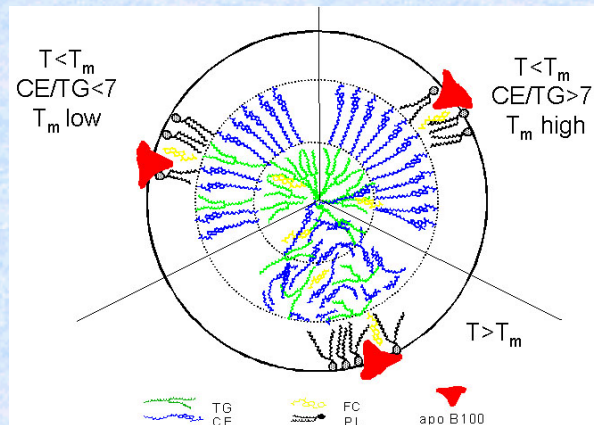

Sketch of the LDL lipoprotein in the 3 different states:

- core liquid crystalline state
- core isotropic state TG, CE, FC, PL denotes triglycerides, esterified cholesterol, unesterified cholesterol, phospholipids.

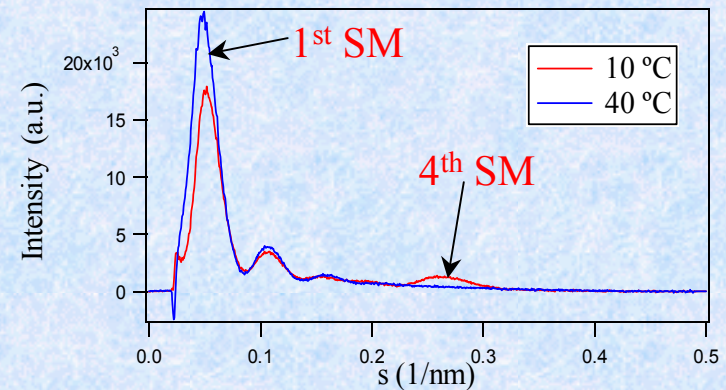

Fig. Static diffraction pattern at different temperatures

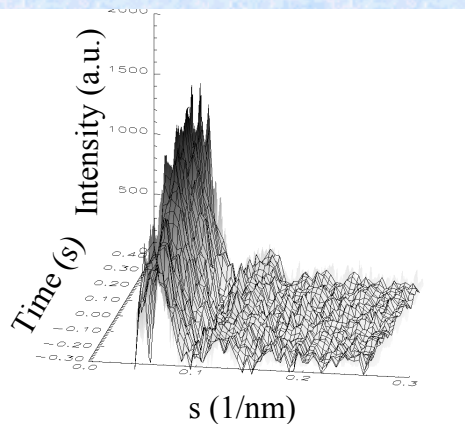
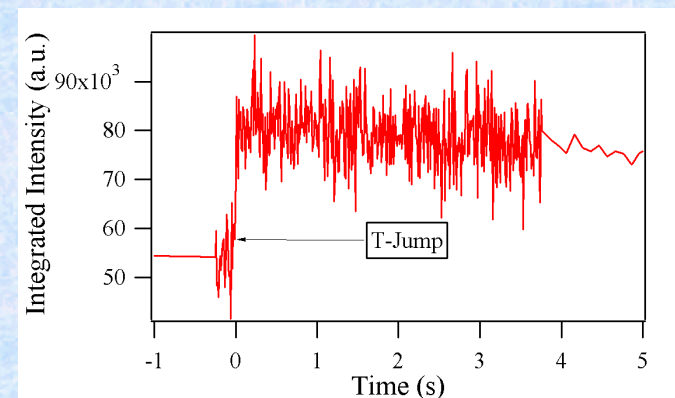

Fig. Time-resolved diffraction pattern during the T-jump  
left pattern – right integrated intensity 1<sup>st</sup> side maximum



AUSTRIAN SAXS - BEAMLINE AT ELETTRA

H. Amenitsch, S. Bernstorff, P. Dubcek, M. Rappolt & P. Laggner





# Cool-jump on Low Density Lipoprotein

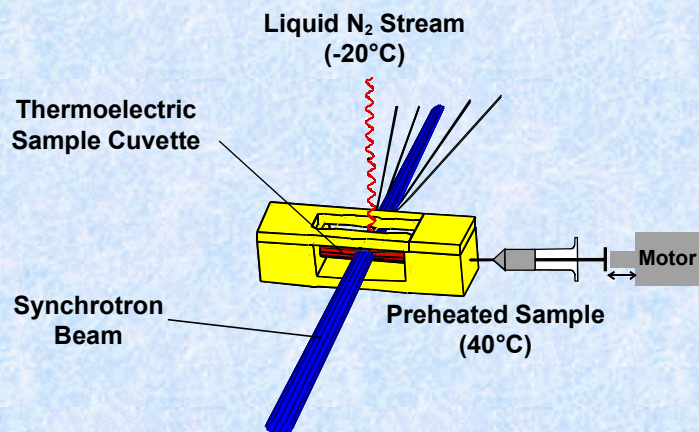

Fig. Sketch of cool-jump set-up

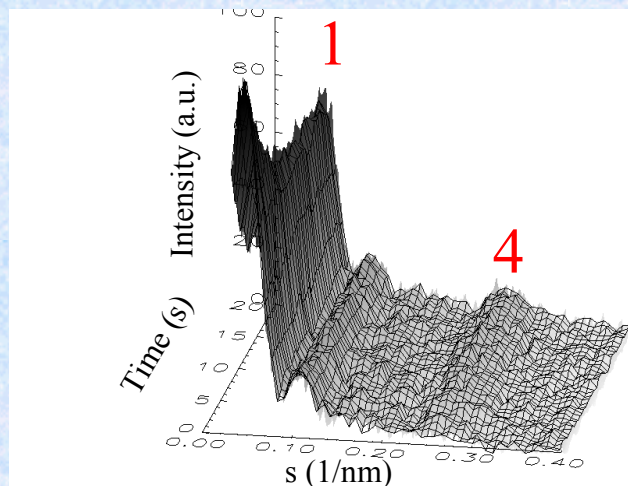

Fig. Time-resolved diffraction pattern during the cool-jump

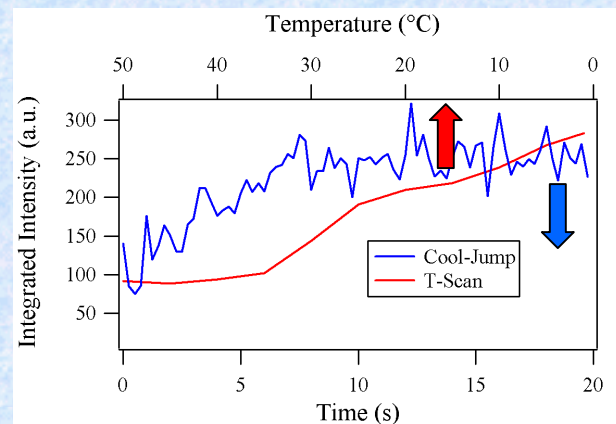

Fig: Integrated intensity 4<sup>th</sup> side maximum

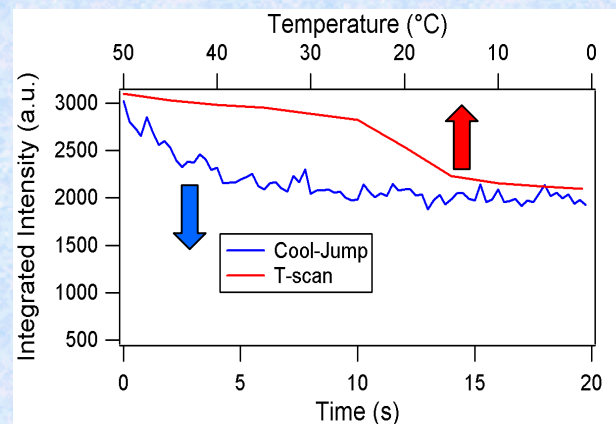
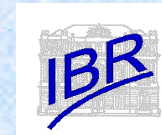
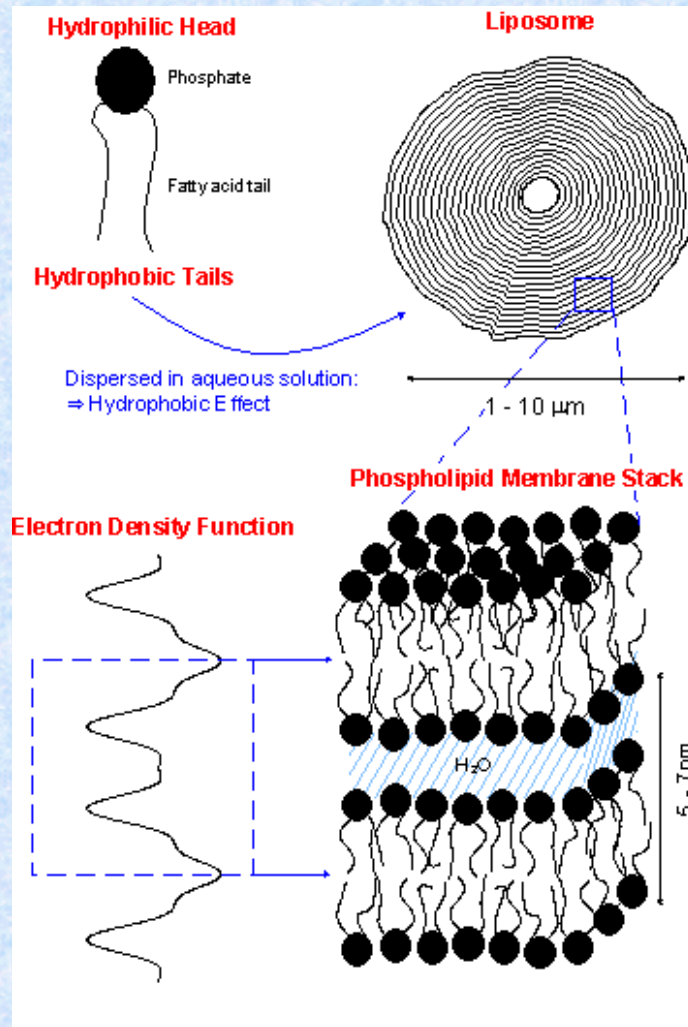

Fig: Integrated intensity 1<sup>st</sup> side maximum



# SAXS - Applications: T-jump Device



The formation of a phospholipid membrane. Phospholipids aggregate spontaneously into ordered supra-molecular structures in the presence of water. This can be explained in simple terms by the fact that phospholipids feature a hydrophilic headgroup (attracting water) and hydrophobic hydrocarbon-chains. The average 1- dimensional repeat distance  $d$ , i.e., bilayer plus waterlayer of the depicted liquid crystalline phase ( $L_a$ ) is in the range of 5-7 nm. The electron density distribution of a bilayer (bottom left corner) has maxima in the headgroup regions and a minimum at the methyl terminus of the hydrocarbon-chains. The dashed rectangle marks the part of the electron density distribution shown in the fig below.

# SAXS - Applications: T-jump Device

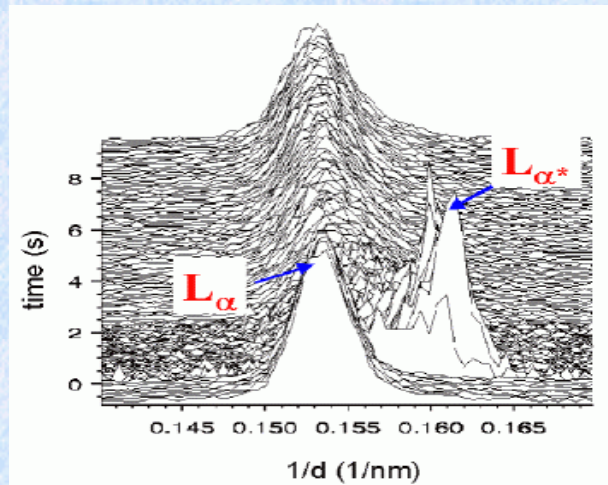

The first order diffraction peaks of a phospholipid sample during a T-jump experiment (time resolution = 5 ms). The IR-laser was triggered at time zero.

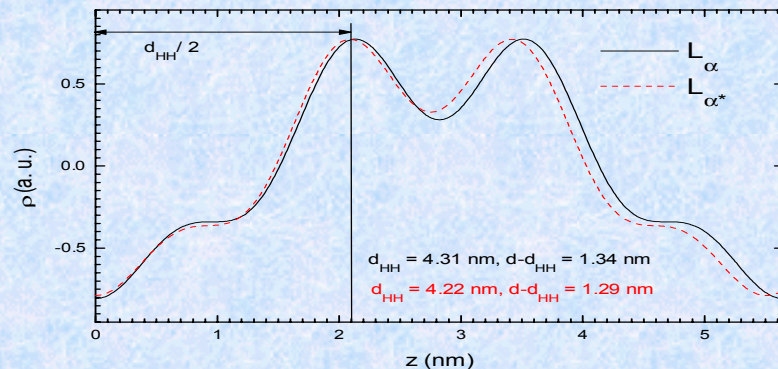

Superimposed electron density distributions of the original  $L_{\alpha}$ -phase (straight line) and of the intermediate phase  $L_{\alpha}^*$  (dashed line) immediately after the laser flash

G. Pabst, M. Rappolt, H. Amenitsch, S. Bernstorff & P. Laggner (1998)



AUSTRIAN SAXS - BEAMLINE AT ELETTRA

H. Amenitsch, S. Bernstorff, P. Dubcek, M. Rappolt & P. Laggner



# T-jumps: Phospholipid Phase Transition

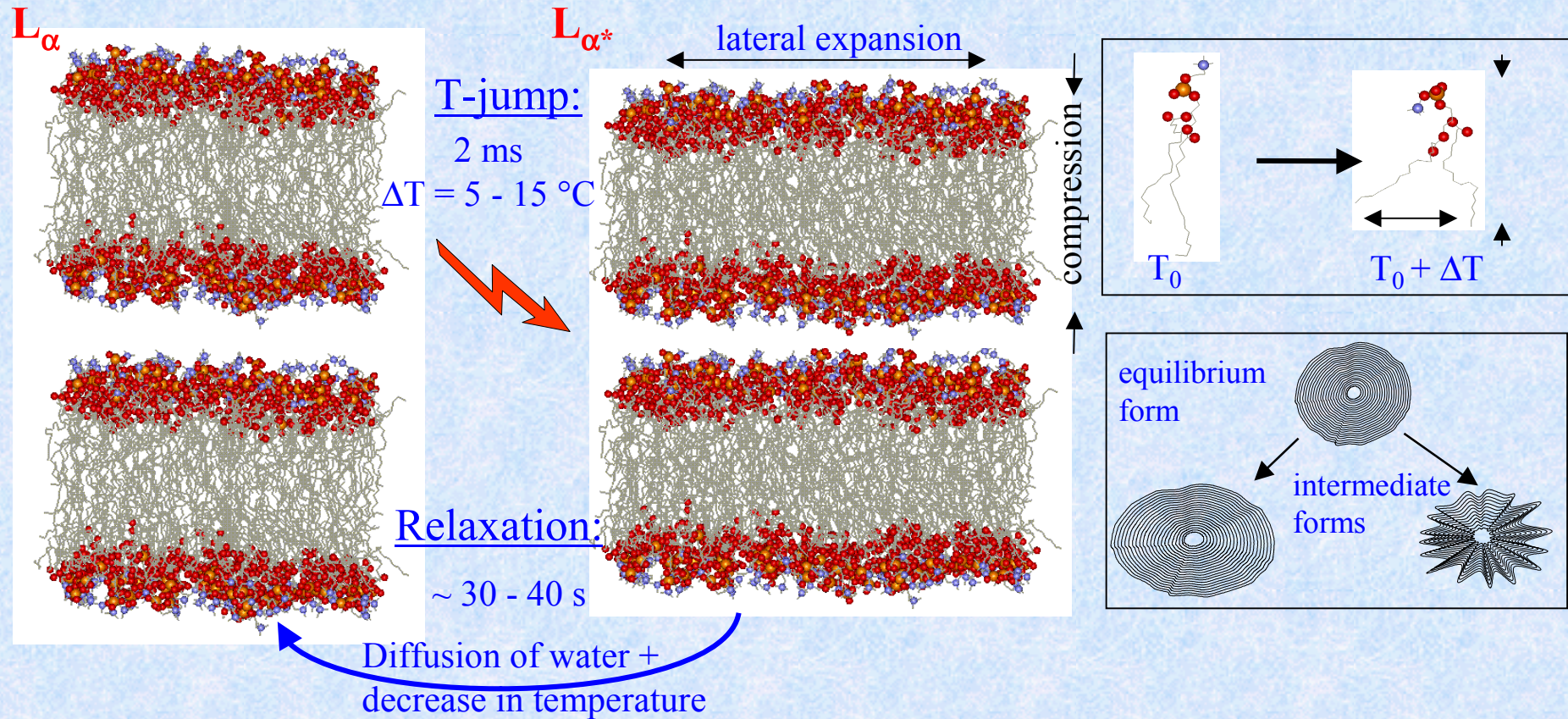

G. Pabst, M. Rappolt, H. Amenitsch, S. Bernstorff & P. Laggner,  
*Biophys. J.*, (2000)



AUSTRIAN SAXS - BEAMLINE AT ELETTRA

H. Amenitsch, S. Bernstorff, P. Dubcek, M. Rappolt & P. Laggner



# High Pressure Cell

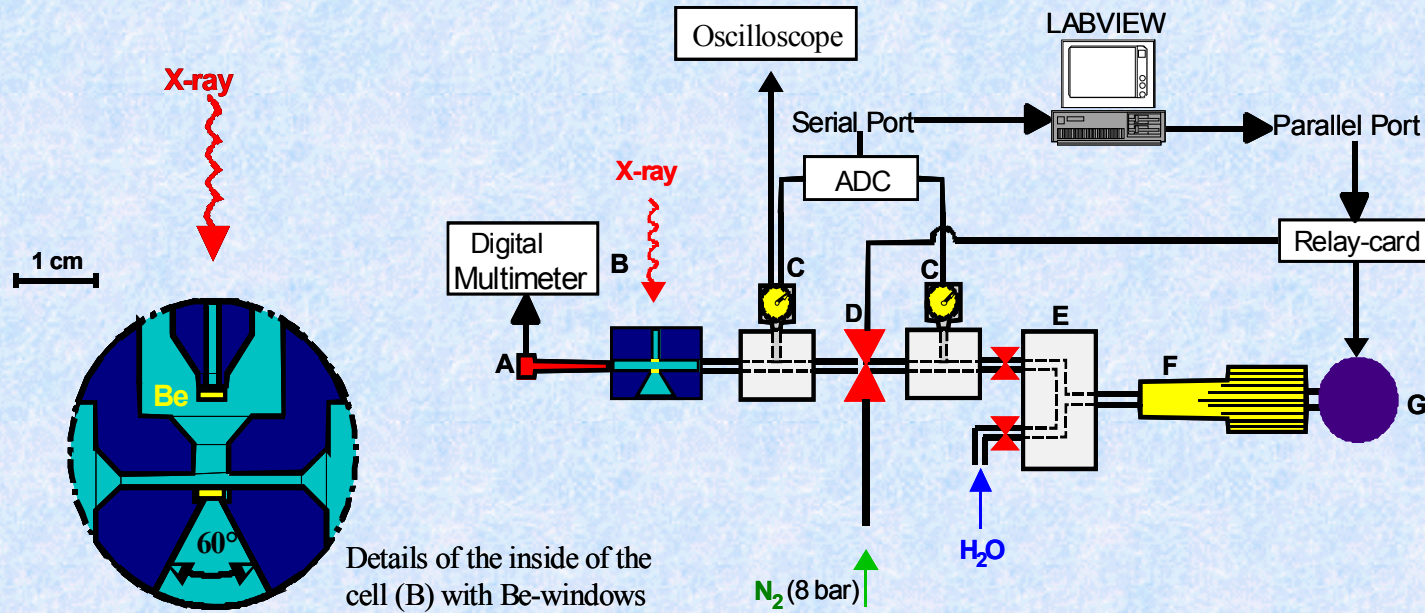

M.Steinhardt, M.Kriechbaum, K.Pressl, H.Amenitsch, P.Laggner and S.Bernstorff, Rev.Sci.Instrum. 70, 1540-1545 (1999).



AUSTRIAN SAXS - BEAMLINE AT ELETTRA

H. Amenitsch, S. Bernstorff, P. Dubcek, M. Rappolt & P. Laggner



# SAXS - APPLICATIONS high pressure cell

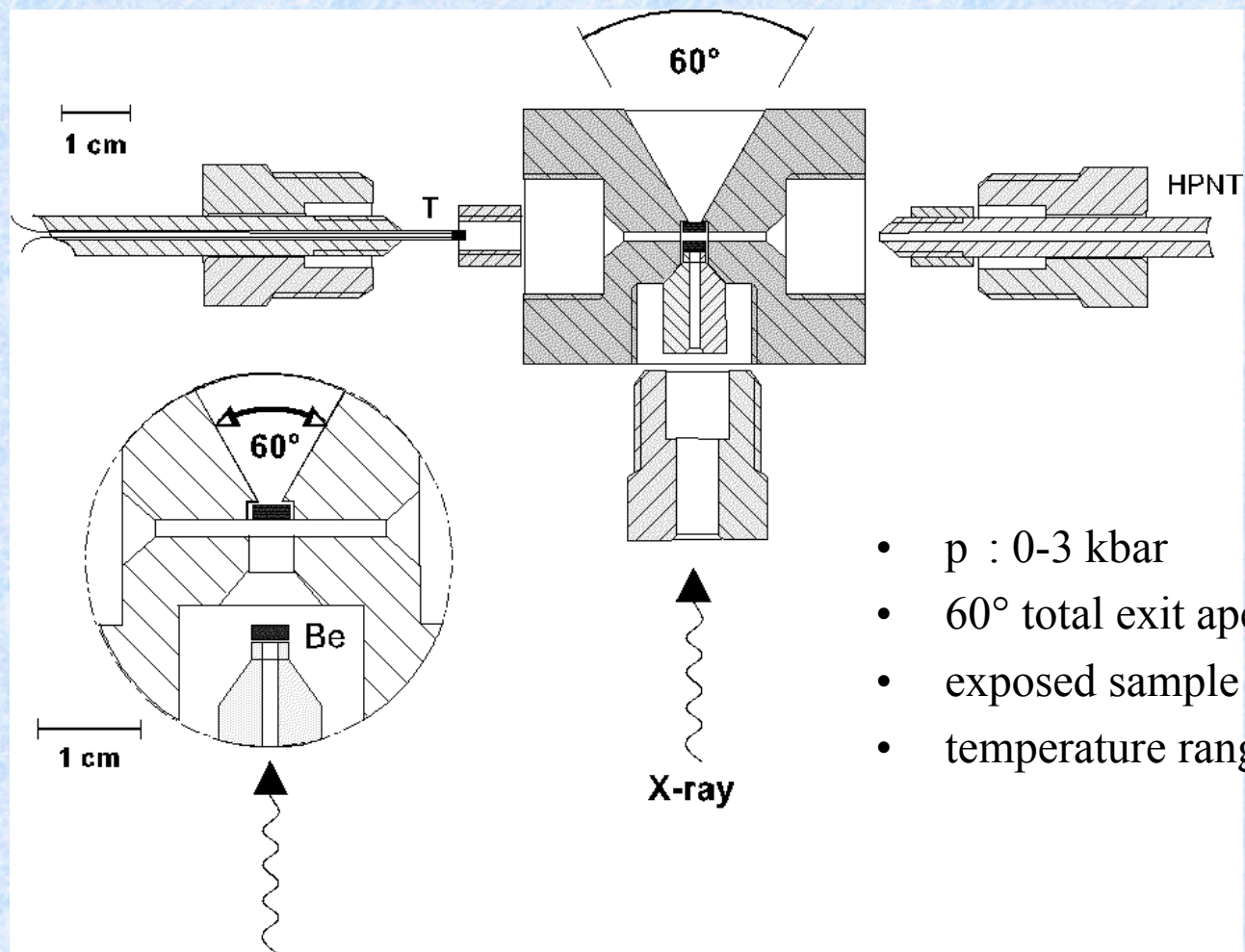

- $p$  : 0-3 kbar
- 60° total exit aperture
- exposed sample volume: 1 ml
- temperature range: 0-80 °C

# SAXS - APPLICATIONS high pressure cell

EXAMPLE: p-jump on DOPE (Dioleoylphosphatidylethanolamine) from 150 bar to 2.3 kbar at 20° C. (A) Phases and (B) SAXS-pattern.  
*M. Kriechbaum, M. Steinhart, P. Laggner, H. Amenitsch and S. Bernstorff*

**A**

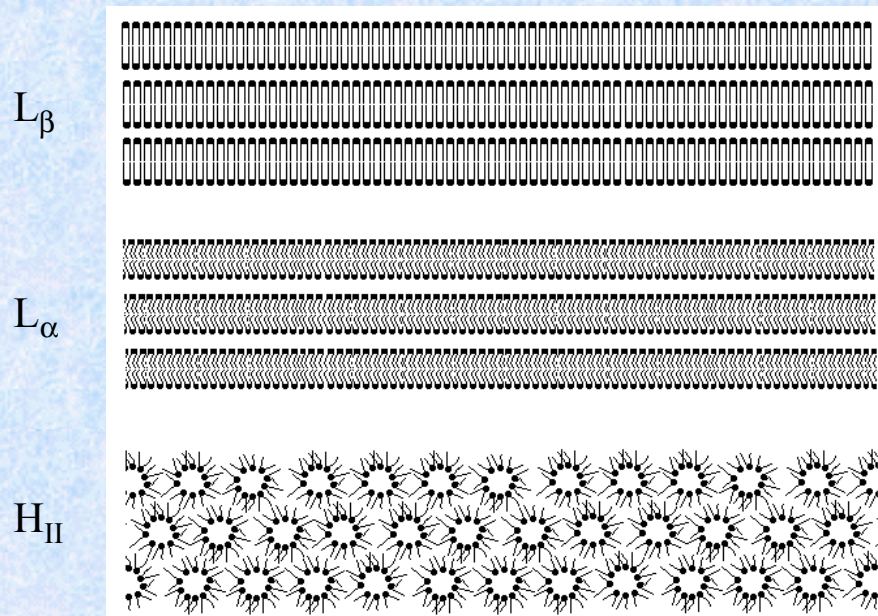

**B**

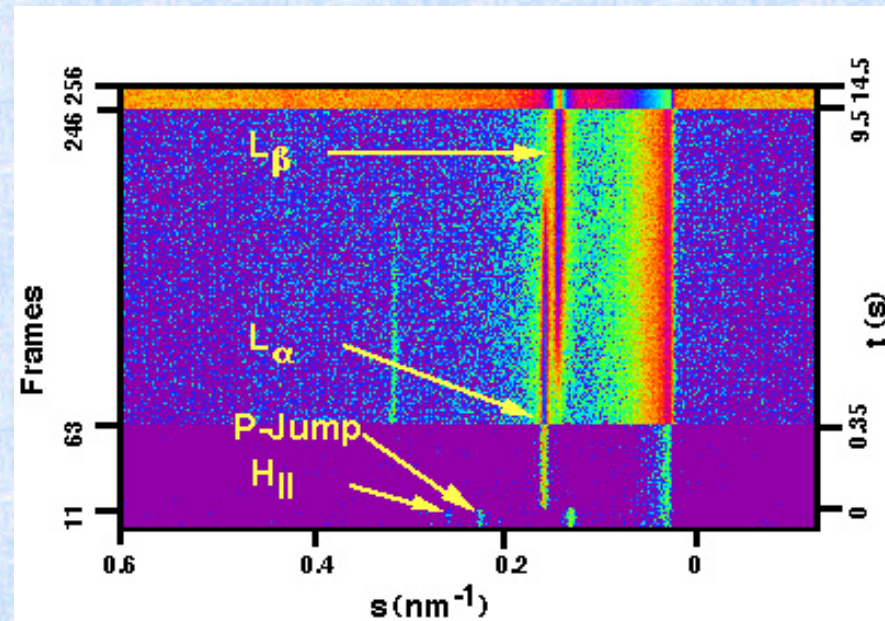

AUSTRIAN SAXS - BEAMLINe AT ELETTRA

H. Amenitsch, S. Bernstorff, P. Dubcek, M. Rappolt & P. Laggner



# The Self-Assembly of thin films as seen by In-Situ SAXS and interferometry

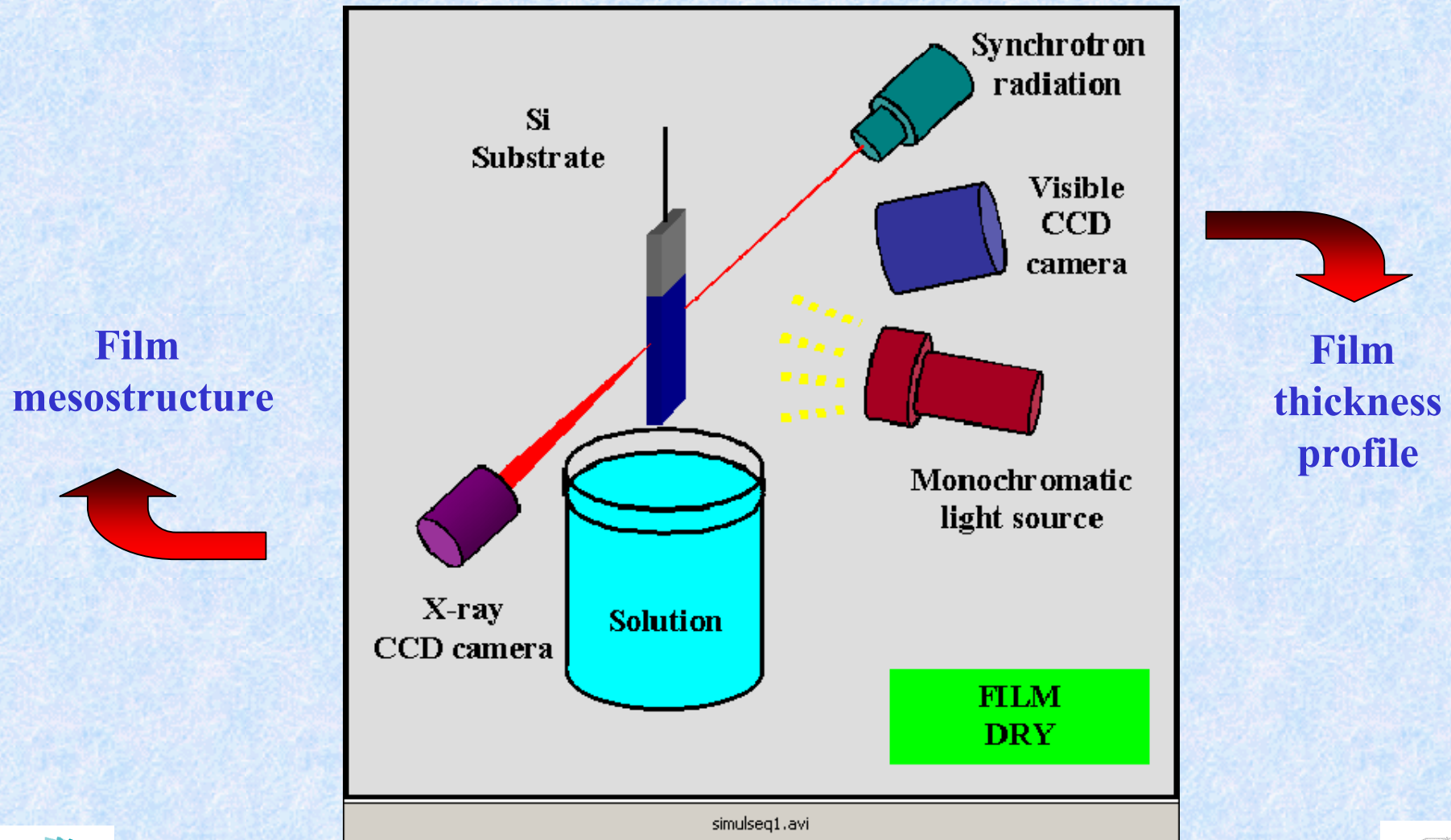

AUSTRIAN SAXS - BEAMLINE AT ELETTRA

H. Amenitsch, S. Bernstorff, P. Dubcek, M. Rappolt & P. Lagner





# Surface diffraction: Formation of aligned mesoporous thin films

CTAB / Si = **0,18**  
H<sub>2</sub>O / Si = 5  
HCl / Si = 0.15  
Ageing time  
Relative Humidity

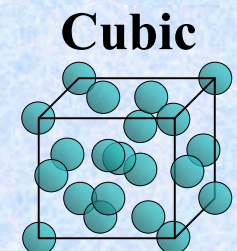
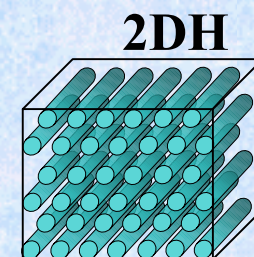
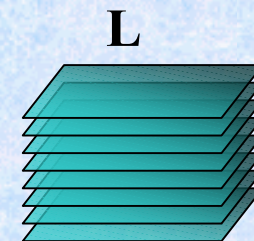
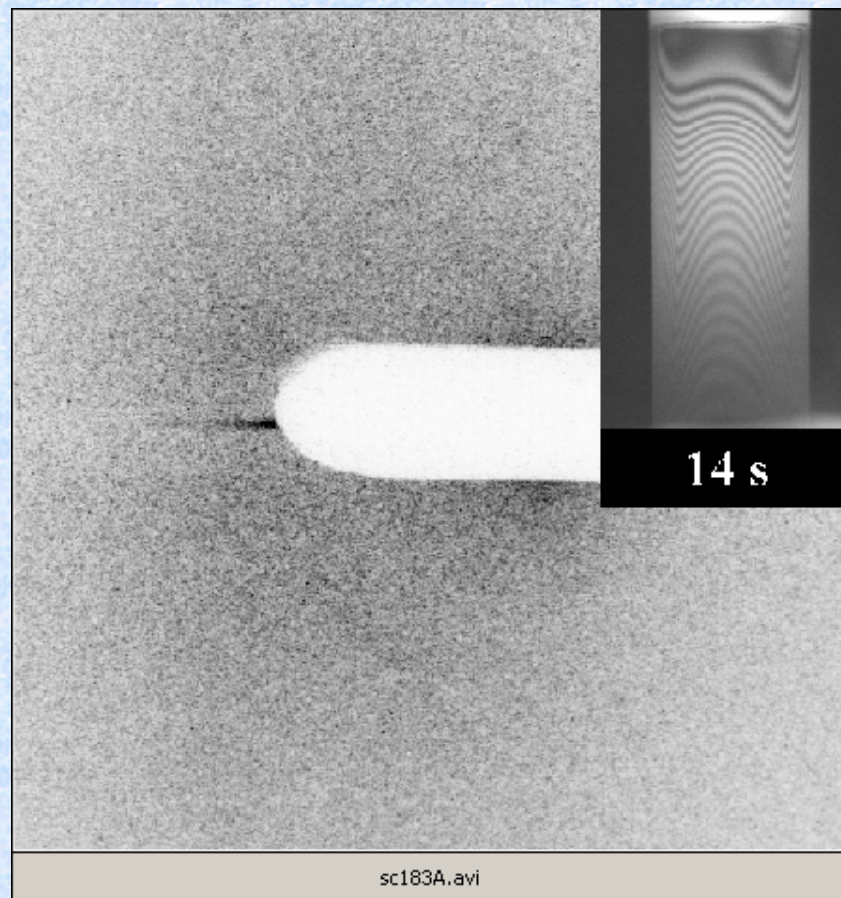

Grosso D, et.al., CHEMISTRY OF MATERIALS 14, 931,(2002)



AUSTRIAN SAXS - BEAMLINE AT ELETTRA

H. Amenitsch, S. Bernstorff, P. Dubcek, M. Rappolt & P. Lagner



# The Modulable Steady State

E. Cagnol et al., *J. Mater. Chem.*, 2002

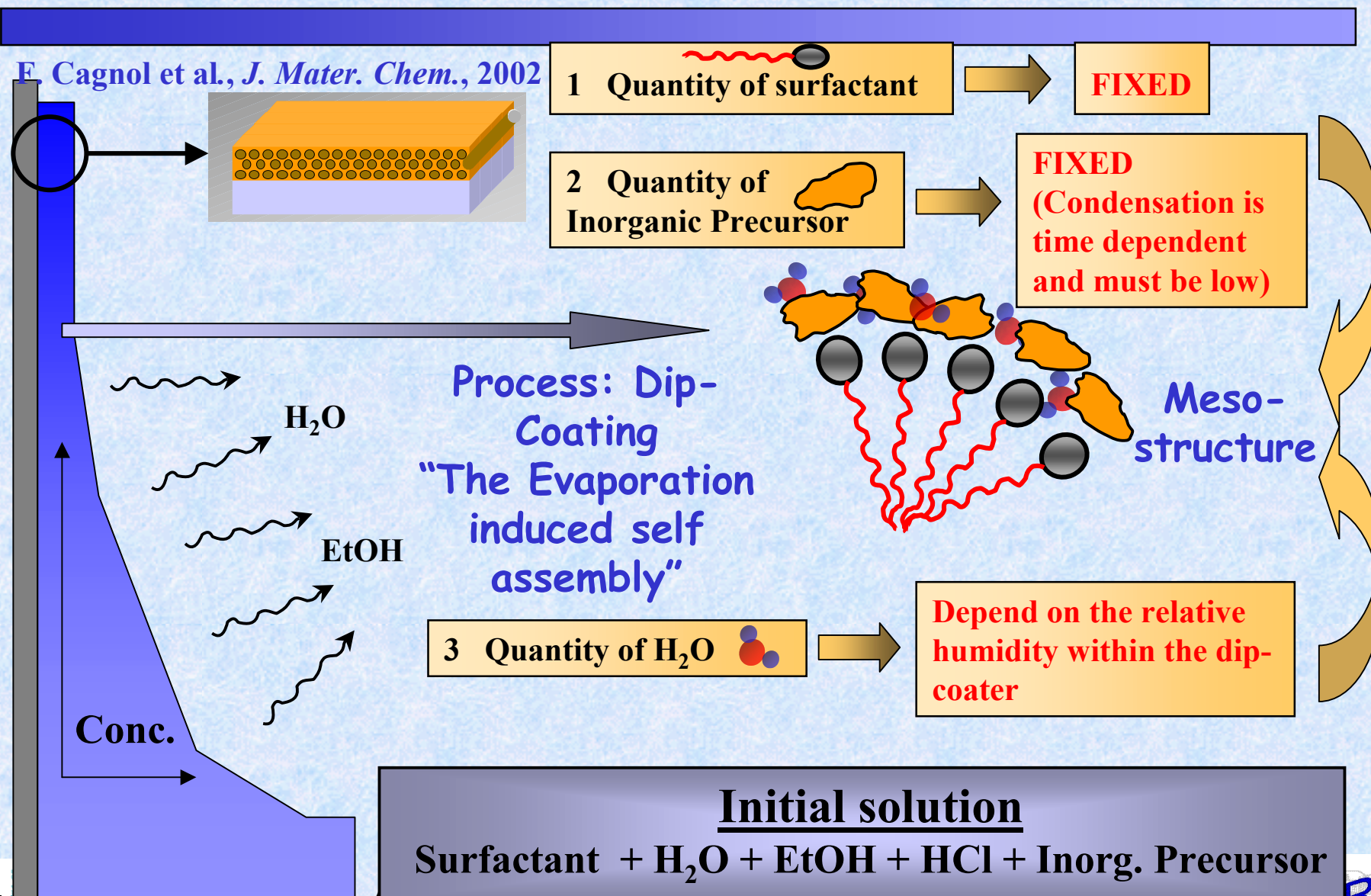

AUSTRIAN SCIENCE FUND FWF

H. Amenitsch, S. Bernstorff, P. Dubcek, M. Rappolt & P. Lagner



# SAXS STUDY OF SPICULES FROM MARINE SPONGES



➤ The scientific name is “Porifera” which translates into “pore-bearing”

**Biomineralisation**

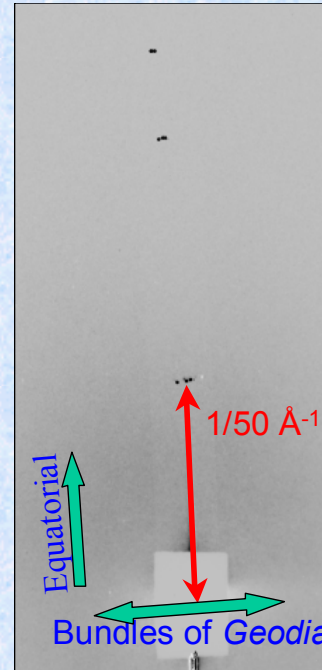
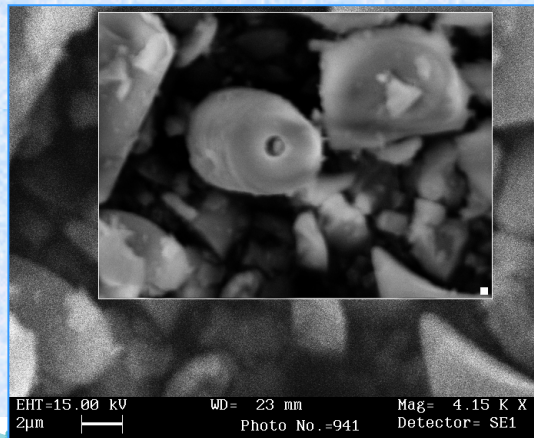

Geodia

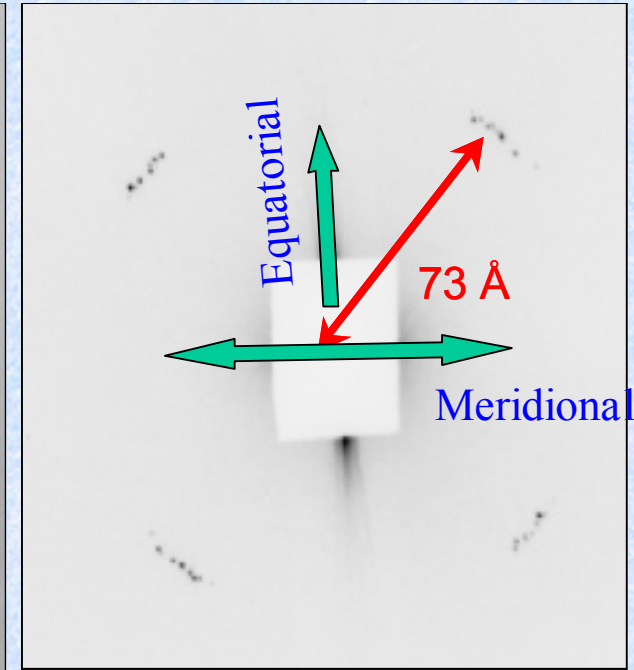

Scolimastra

Croce, G. et al., 2004. *Biophysical Journal* 86:526-534.

Croce, G., et al., 2003. *Microscopy Research and Technique* 62:378-381



AUSTRIAN SAXS - BEAMLINE AT ELETTRA

H. Amenitsch, S. Bernstorff, P. Dubcek, M. Rappolt & P. Laggner



# Surface Diffraction Lipids – Surface Chemistry

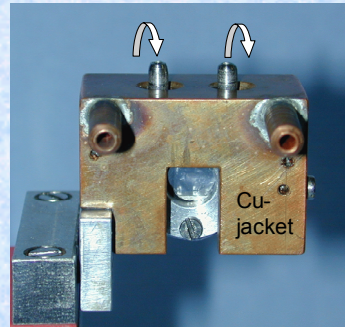
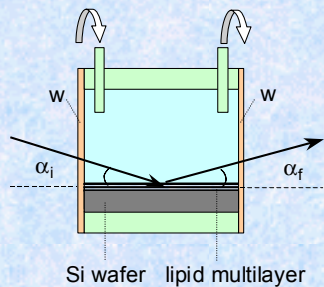

**Sketch and photograph** of the sample cell in transmission geometry for GISAXS.

**Sketch** of the exp. set-up and 2D diffraction pattern of POPC and 0.5 M LiCl

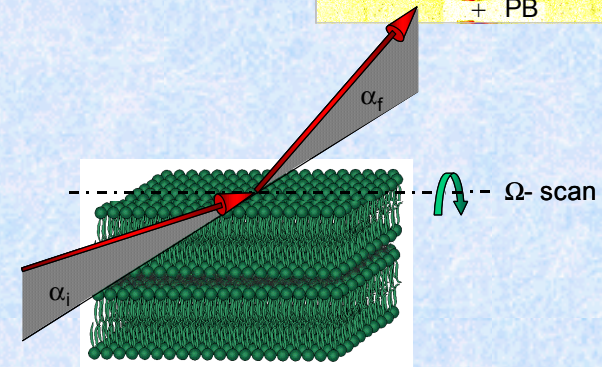
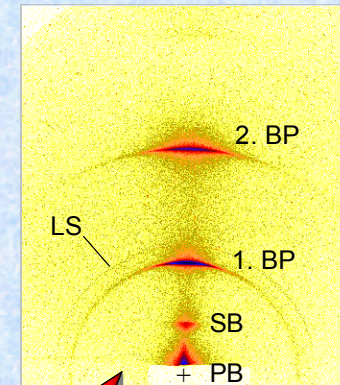

# Surface Diffraction Lipids – Surface Chemistry

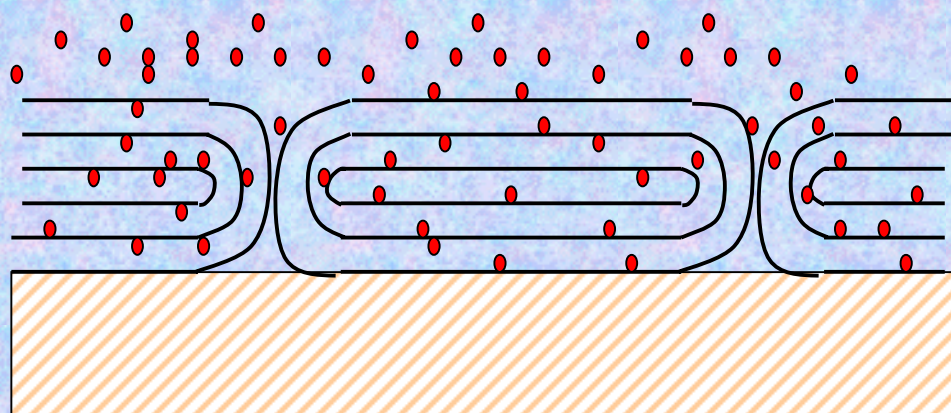
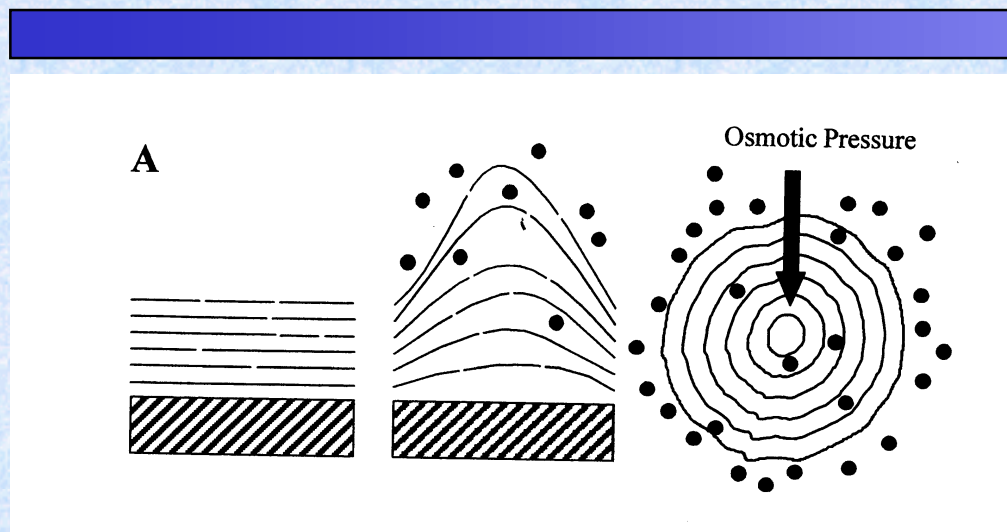

Amenisch, H., et al., (2004) Langmuir

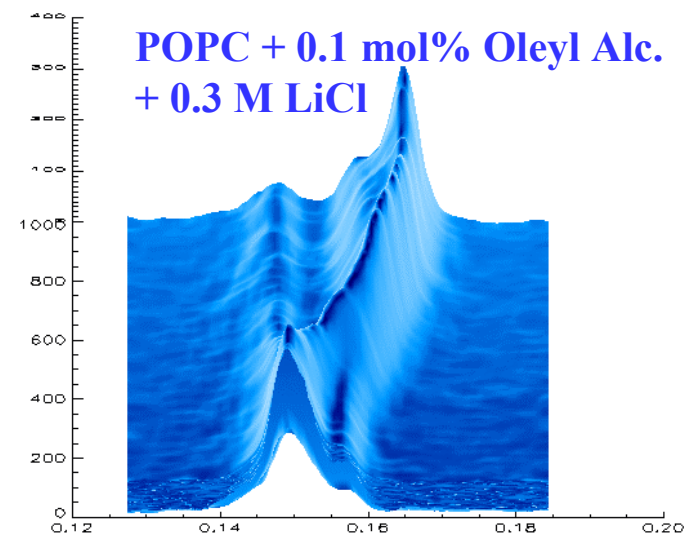
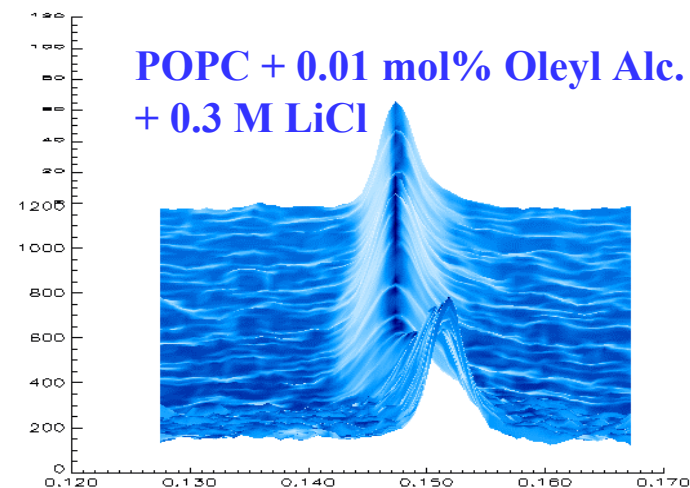

AUSTRIAN SAXS - BEAMLINe AT ELETTRA

H. Amenitsch, S. Bernstorff, P. Dubcek, M. Rappolt & P. Lagner

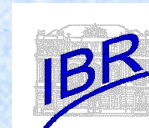

## Summary - Outlook

-Why?

Extreme?

-How to trigger transitions?

-Applications

Biology and Biomedicine

Physical Chemistry

Material Science

“Frontiers in Material Science”, Science, 277, (1997), 1213-1253

-Outlook:

USE of NEW DETECTORS!

Use of coherence in SAXS!

(photon correlation spectroscopy)

Use of new sources FEL's!

Think for yourself of new ways  
to use SAXS and SR



AUSTRIAN SAXS - BEAMLINe AT ELETTRA

H. Amenitsch, S. Bernstorff, P. Dubcek, M. Rappolt & P. Laggner

