

## Pirani gauge, thermal conductivity gauge

Change of the thermal conductivity with pressure

Reliable and simple system.

Pressure range:

atmospheric pressure to  $< 0.1$  Pa

A resistor with a large temperature coefficient is mounted inside the vacuum. This resistor is heated to a constant temperature and the required heating current is a measure of the pressure.

The electronic circuitry (Wheatstone-bridge) provides temperature compensation and linearization of the pressure reading.

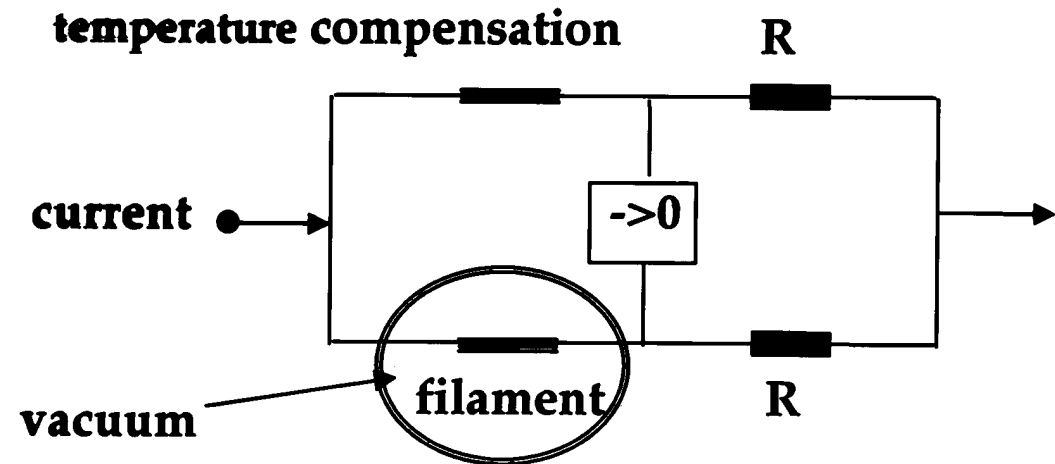

## **Cold Cathode Ionisation Gauge, Penning Gauge**

Based on the operating principle of an ion pump:

Ratio of pressure and pump current  $\sim$  constant.

Useful pressure range :  $10^{-2}$  to  $10^{-7}$  Pa

Limitations:

At high pressure the discharge is unstable (arcing)

At low pressure the discharge extinguishes  $\rightarrow$  zero pressure reading

Leakage current in the cables and in the gauge can simulate a higher pressure

Contamination of the gauge may change the calibration.

Extended operation at very high pressure can contaminate the gauge  $\rightarrow$  required demounting and cleaning of the gauge.

Improved version for low pressures are on the market: Inverted magnetron gauge

## Hot Filament ionization Gauge

### Operating principle

Residual gas molecules are ionized by the electrons emitted from a hot filament.

Ions are collected by a "collector electrode".

This ion current is proportional to the gas density,  $n$ , and hence to the pressure,  $P$ .

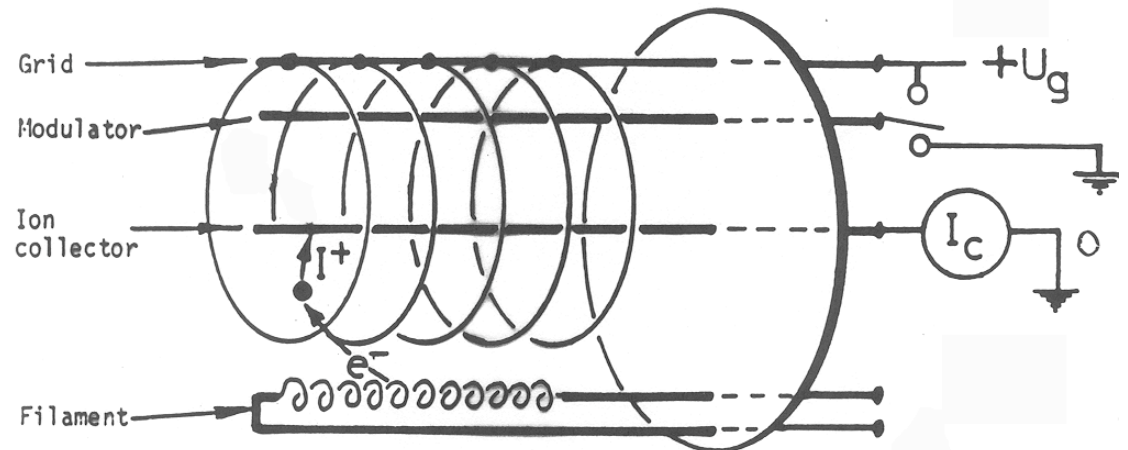

The ionization probability  $P_i$

(number of ion–electron pairs produced per m and per Pa) depends on the type of molecule and on the kinetic energy of the electrons.

Ion collector current :  $I^+ = I_e P_i L P$

Where  $I_e$  emission current of the filament

$L$  path length of the electrons

$P$  pressure

## Gauge Sensitivity

$$S = P_i L \quad [\text{Pa}^{-1}]$$

Obtained by calibration with a known pressure ( $N_2$ )

→ Nitrogen equivalent pressure  $N_2$ .

→ To measure a pressure for another gas, the relative gauge sensitivity for this particular gas with respect to nitrogen must be known.

→  $S_i/S_{N_2}$  must be known for different gas species.

For  $H_2$ , one finds typically  $S_{H_2}/S_{N_2} \sim 0.38$

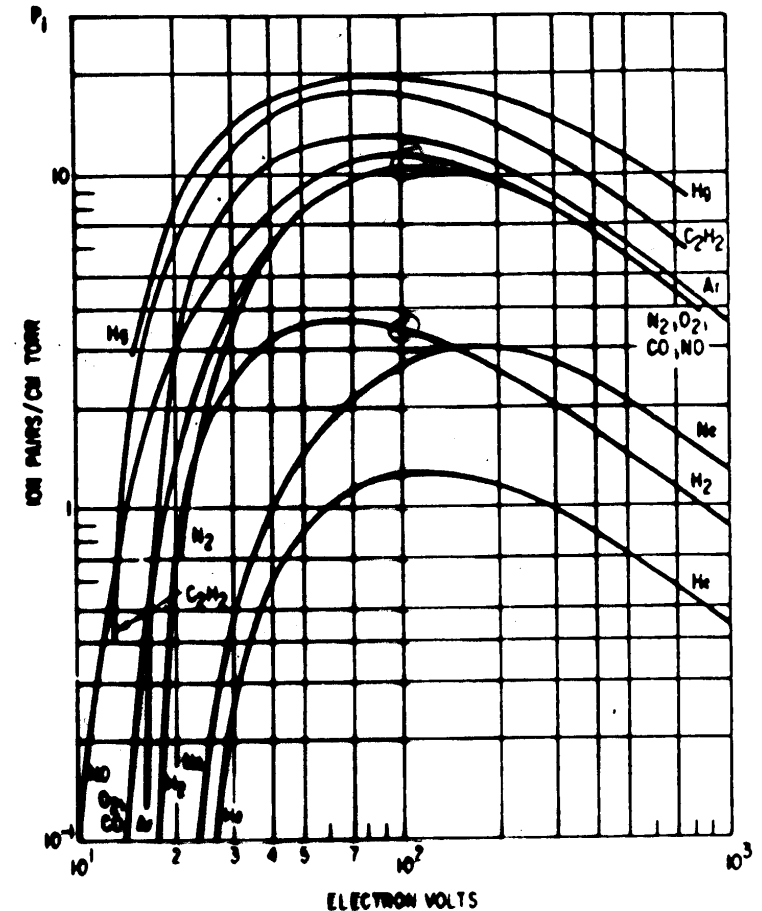

FIGURE 2. Probability of ionization as a function of electron energy for various gases at 1 Torr and 0°C.<sup>1</sup>

## “Outgassing” of an Ionization Gauge

Electrons emitted from the filament, reach the grid electrode with an energy of approximately  $\sim 150\text{eV}$  and may heat-up the grid and desorb gas molecules.

-> pressure increase which disturbs the measurement.

-> To suppress this effect, the grid and all other electrodes must be cleaned.

A common method to avoid this disturbance:

the emission current is increased to heat the grid electrode temporarily to a very high temperature. -> Outgassing mode of the gauge.

Ultimate pressure limitation:

Finite residual current -> limits pressure reading

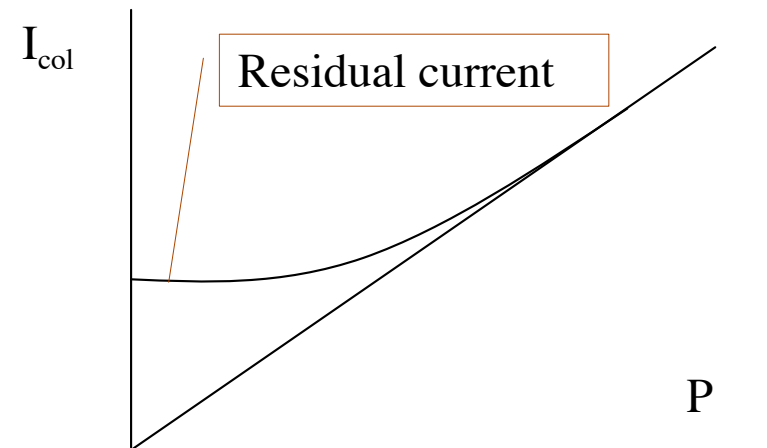

## X-Ray Limit of an Ionization Gauge

Electrons, which hit the grid produce soft photons (x-rays) due to Bremsstrahlung.

A small fraction of these photons can reach the collector electrode and liberate photo-electrons which return to the grid -> this current is equivalent to a positive, “x-ray current”  $I_x$ , which is independent of the pressure.

The correction of this effect can be done by the «modulation» method

### ‘Modulated Bayard-Alpert’ gauge

Modulator electrode	
measurement (1), + $U_{\text{grille}}$	$I_1 = I^+ + I_x$
measurement (2), 0 V,	$I_2 = \square I^+ + I_x$
Corrected collector current	$I^+ = \frac{I_1 \square I_2}{1 \square \square}$

The modulation factor:  $1 - \square$

can be determined easily by an independent measurement at high pressure where  $I^+ \gg I_x$ .

**Alternative design of an ionization gauge:**

Ions are 'extracted' from the grid volume to a collector, which is 'optically' screened from the photons of the grid.

**-> Extractor gauge by Redhead**

- R Reflector, bias voltage
- K Filament, cathode
- C Ion collector, at ground potential
- A Anode (grid)

Ions are extracted from the grid volume through a mask.  
The ion collector is 'optically' shielded from the x-ray photons produced at the grid.

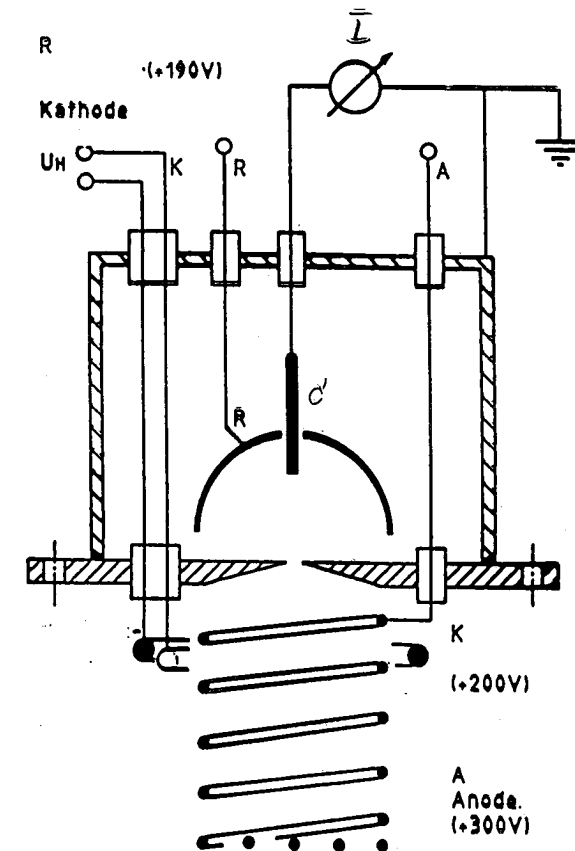

## Partial Pressure Measurement

Combination of an ion source with a mass spectrometer.

- 1) Ion source
- 2) Quadrupole mass filter
- 3) Ion collector, Faraday-cup or secondary electron multiplier

Operating principle of the quadrupole mass filter :

Ions with different mass to charge ratio are injected into the quadrupole structure. As they traverse the structure, ions are subjected

to a periodically varying transverse electric field, which excites transverse oscillations.

Ions with an incorrect charge to mass ratio have unstable orbits, are lost and do not reach the collector.

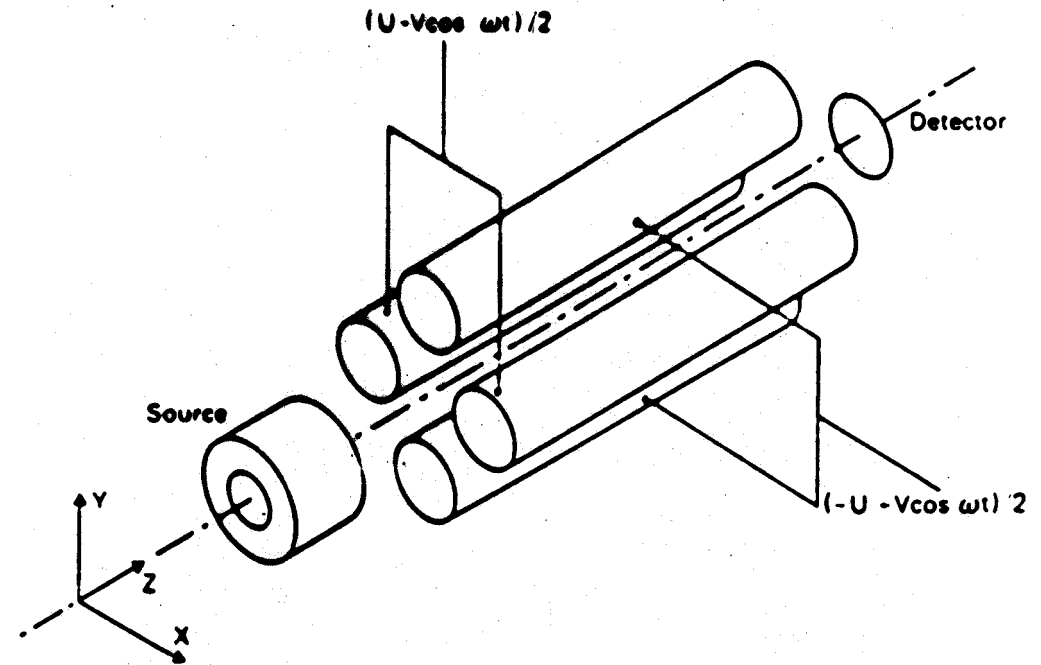



The ion trajectories are described by the equations :

$$\ddot{x} + \left(\frac{e}{m} r_o^2\right) \square x = 0$$

$$\ddot{y} \square \left(\frac{e}{m} r_o^2\right) \square y = 0 \quad \text{and} \quad \ddot{z} = 0$$

$r_o$  is the radius of the structure and  $\square$  the potential:  $\square = U \square V \cos(\square t)$ .

With  $a = 4 \frac{e}{m} \frac{U}{\square^2 r_o^2}$  and  $q = 2 \frac{e}{m} \frac{V}{\square^2 r_o^2}$  -> **Mathieu equation**

$$\frac{d^2 u}{ds^2} + \{a \square 2q \cos(2s)\} u = 0$$

Solutions define regions with stable and unstable motion. Only the ions ( $e/m$ ) with stable trajectories through the quadrupole mass filter are measured.

### Stability Diagram

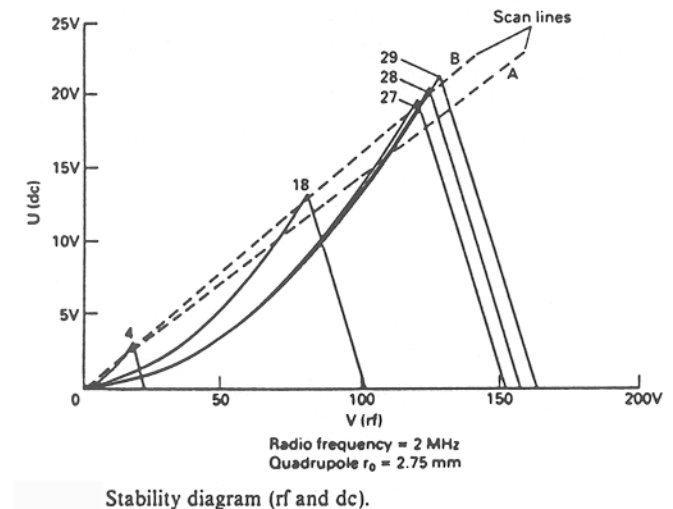

---

## Residual gas spectrum

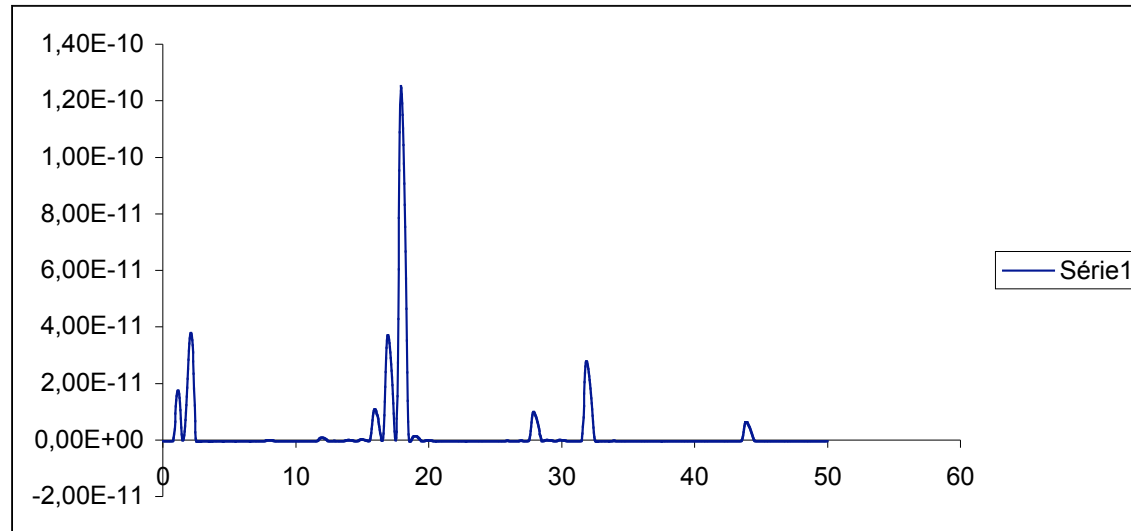

Ion current (A) corresponding to a particular molecular species (e/m)

N<sub>2</sub>-equivalent pressure can be obtained with a total pressure gauge.

**Qualitative analysis** is relatively straightforward, e.g. the identification of:



Distinction between CO/N<sub>2</sub> requires knowledge of the “**cracking pattern**” of the two molecular species.

**Quantitative analysis** requires a perfectly calibrated system for each residual gas component and can be very difficult. -> Note: do not rely on the manufacturer's calibration.

**Typical cracking patterns of common molecules**

peak	2	14	15	16	17	18	20	27	28	32	40	44
H <sub>2</sub>	100											
CH <sub>4</sub>	2.4	10.7	85	100								
H <sub>2</sub> O				1.8	27	100						
N <sub>2</sub>		6.2							100			
CO		0.9							100			
O <sub>2</sub>				18						100		
A							13				100	
CO <sub>2</sub>				7.5					18.5			100

Principal peak of each species is normalised to 100%.

---

## Residual gas spectrum of a baked, 'clean' uhv system

Qualitative observations:

Absence of peaks 17,18 : H<sub>2</sub>O has been removed during the bakeout.

Absence of peaks due to hydrocarbons: small trace of CH<sub>4</sub>

Presence of peak 40 may indicate small air leak, or release of argon from an ion pump.

Warning:

CH<sub>4</sub> can be produced by the hot filament of an ionization gauge

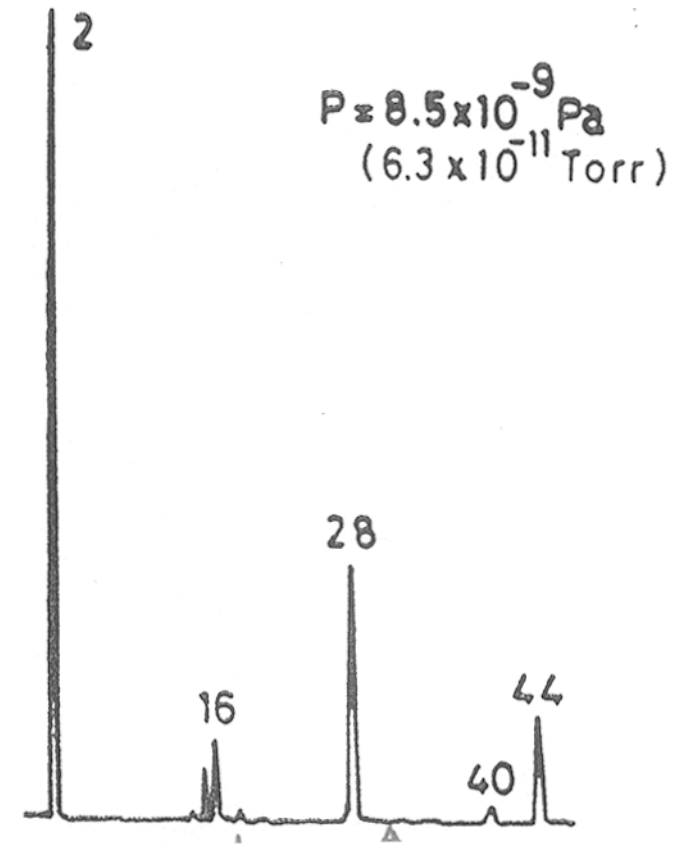

## Helium leak detector

Mass spectrometer tuned to Helium, which is commonly used as the 'tracer gas'.

Purpose of the  $\text{LN}_2$  filled cold trap is to remove oil vapours of the diffusion pump as well as water vapour from the spectrometer cell

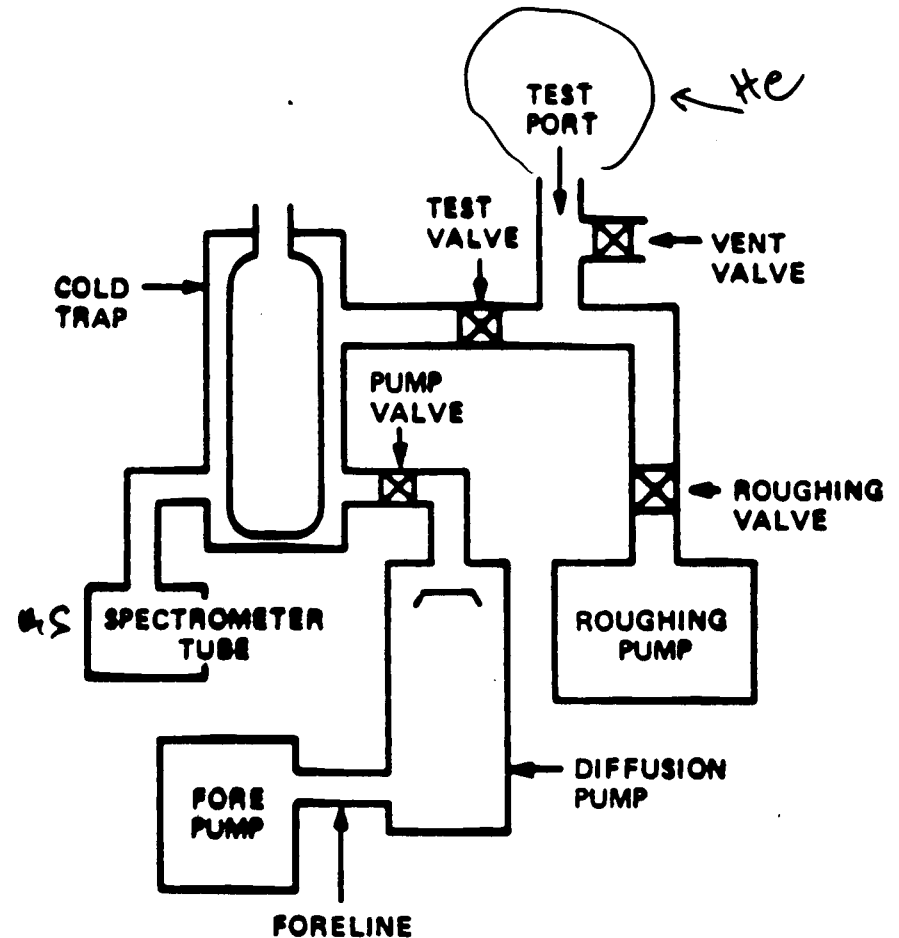

## Leaks and leak detection

Common leaks to atmospheric pressure:

Gaskets

Porosities in the materials

Cracks in welds

**Virtual leaks:** are not found by a conventional leak check

Porosities, a dead volume enclosed inside the system

Example of a virtual leak: The volume enclosed by a bolt in a threaded hole.

Solution: bolts have to be drilled with a central hole or a separate hole must be drilled to pump the dead volume.

In a large vacuum system, leak checks of all sub-components are mandatory.

A global leak check after complete assembly should only concern those joints, which have been made during the final installation phase in the accelerator.