

## **Ray tracing Laboratory**

School on Synchrotron Radiation

April 26<sup>th</sup> - 29<sup>th</sup> 2004

*A. Bianco, D. Cocco, F. Zanini*

### **Introduction**

Ray tracing is a powerful tool to estimate and understand the behaviour of a complicated object. When in optics one has to deal with a lot of elements (may be lenses, mirrors, diffractive objects and so on) it's surely possible to estimate the final behaviour of the system by first principles (i.e. simply satisfying complicated equations) but...

There are so many parameters to take into consideration, misalignment, slope errors, high order aberrations, residual astigmatism and many others than, practically, it's impossible to estimate carefully the final system performances.

On the other hand, a ray-tracing program, even if it is a very good program, is not able to substitute an optical designer in the definition of the parameters of a beamline.

For this reason, the equations at the basis of the optics for synchrotron radiation must not be forgotten but perfectly understood.

In particular, in the case of the synchrotron radiation, the following statements must be recorded. Since we have to deal with soft or hard x-ray, the transmission of the elements is negligible or useless, so, no lenses can be used. Moreover, the reflectivity of every material in both these ranges drop down faster with the increasing of the grazing angle of incidence. Therefore, very grazing angle is necessary. Typical values could be  $1-2^{\circ}$  for the soft X-ray range and  $0.2-0.3^{\circ}$  for the hard X-ray radiation. This introduces further problems. The radiation becomes "sensible" to any surface imperfection. For this reason acceptable difference between the real and desired slope could not exceed few  $\mu\text{rad}$  RMS on a 1-m length mirror.

Another problem is the high power radiation impinging on the mirrors. This causes an unavoidable heat load that increases the deformation of the mirrors.

All this problems and boundaries condition must be strictly taken into consideration before run a ray tracing program, because great difference between simulated and real values are easy to be obtained.

So, we can conclude saying that ray tracing is fundamental for a good design of a beamline but is not only useless, but also dangerous, if is not used properly.

### **How a ray-tracing program works**

As mentioned above, the ray-tracing program must "simulate" the behaviour of a photon during its travel. Even if a rigorous quantistic description (involving wave functions) should be used, we can approximate the photons as object travelling along a straight line (exactly as made in the geometrical optics). The only thing to take into consideration is the effect on the trajectory of the optical elements. In fact, a mirror can be perfectly simulated by this representation. The photons arrive on the surface, the surface is locally simulated as a plane mirror and a specular reflection takes part. This is exactly what a ray-tracing program does, even if the physic behind this simple process is quite complicated. Another story is the problem of the efficiency (i.e. how many photons are reflected by the mirror and how many are adsorbed) but this is out of the scope of these notes.

Therefore, we now can simulate the behaviour of a photon on a mirror, but, following it step by step, we must start from the source. First, we need to know the characteristic of the source. The programs, typically, are able to simulate point sources, rectangular sources, gaussian (both in angular and spatial), monochromatic, polychromatic (some different line of energy), continuous energy range, and sometimes also to simulate a real synchrotron source, a bending magnet, an undulator or a wiggler. Practically it generates a series of photons each one with a defined position in space, a trajectory, energy, and in some cases a polarisation degree (a value useless and meaningless for single photons).

To generate real synchrotron sources some complicated equations must be solved or, alternatively, the electron trajectory and the emission from any electron must be simulated. This procedure is quite complicated and in most of the cases is not necessary. For instance, to simulate an undulator source without the aid of external programs, a gaussian distribution is a good approximation. The gaussian shape should be defined by the following equations:

$$(1) \quad \Sigma_x = (\sigma_x^2 + \sigma_R^2)^{1/2} \quad \Sigma_y = (\sigma_y^2 + \sigma_R^2)^{1/2}$$

$$(2) \quad \Sigma'_x = (\sigma'_x{}^2 + \sigma'_R{}^2)^{1/2} \quad \Sigma'_y = (\sigma'_y{}^2 + \sigma'_R{}^2)^{1/2}$$

where  $\Sigma_x$   $\Sigma_y$   $\Sigma'_x$   $\Sigma'_y$  are the spatial and angular divergences of the photon beam,  $\sigma_x$  is the nominal electron beam size in the horizontal direction (Elettra case is typically 0.24 mm),  $\sigma_y$  is the nominal electron beam size in the vertical direction (Elettra case is 0.04 mm),  $\sigma'_x$  is the nominal electron beam divergence in the horizontal direction (Elettra case is 0.03 mrad),  $\sigma'_y$  is the nominal electron beam divergence in the vertical direction (Elettra case is 0.017 mrad). The dependence of the emitted radiation from the energy is related to following relations:

$$(3) \quad \sigma_R = 0.15 (\lambda L)^{1/2} \text{ and } \sigma'_R = 1.30 (\lambda/L)^{1/2}$$

L is the undulator total length and  $\lambda$  is the selected photon wavelength.

The energy distribution of the source is fundamental to understand the behaviour of the beamline. The first step is the simulation of a perfect monochromatic source. In this way one have the exact idea of what happens at the selected energy. Another important parameter is the divergence. The ideal divergence of a synchrotron source is quite small. Nevertheless, the angular distribution is big enough to light the full optics and to introduce errors induced by the divergence (i.e. non-paraxial approximation necessary). For this reason, a real beamline and also a simulated one should have a pinhole some meter after the source to adsorb all the radiation out of a specified distribution cone (typical divergence accepted by a beamline is less then  $0.05 \text{ mrad}^2$  for the

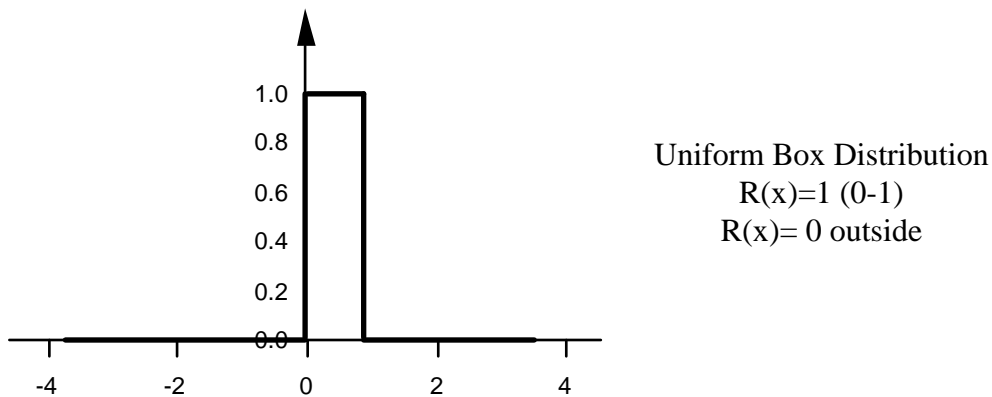

Fig. 1 Random box distribution.

soft x-ray beamline and some mrad<sup>2</sup> for the HXR ones). In any case, also a gaussian distribution could not be so easy to be simulated. Let us consider the possibility to write a program by ourselves. In this case, a standard programming language gives a random distribution inside a box (typically 0-1). It is necessary to use a random distribution because the number of photons used in a simulation could not be too high. The use of 5000-10000 ray is already a number great enough, but only if the rays are randomly distributed. The box distribution (R(x)) is easily defined as a function that is equal to 1 inside the range 0-1 and is zero outside, i.e. as shown in fig.1.

Vice versa, the Gaussian distribution is defined by the equation in fig. 2

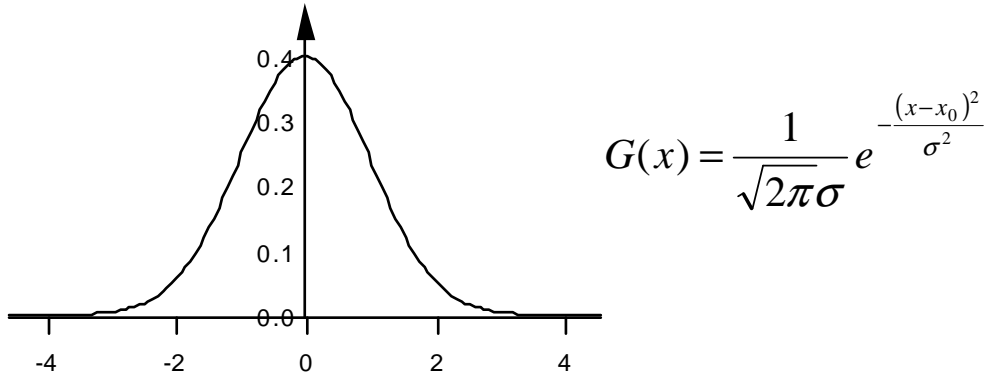

Fig. 2 Gaussian distribution with the equation that define it.

Now, the probability to found a photon (or whatever) gaussian distributed in the interval between  $-\infty$  and  $x_1$  is:

$$(4) \quad P(x)[-\infty; x_1] = \int_{-\infty}^{x_1} G(x) dx$$

Since the probability to found a value between  $-\infty$  and  $+\infty$  for a gaussian distribution is 1, the easiest way to random distribute elements with gaussian shape is the following. First, found a value V between 0 and 1 for the equation R(x) and impose this value to the probability distribution P(x) i.e.

$$(5) \quad R(x) = V[0 - 1] = P(x)[-\infty; x_1] = \int_{-\infty}^{x_1} G(x) dx$$

Now, the value  $x_1$  is the value assigned to our photons. Following this procedure for every photon, one defines exactly a gaussian distribution.

Let us now spend some more words about the mirrors. Every program has a collection of shapes available. Typical shapes are Plane, Spherical, Elliptical, Cylindrical, Toroidal, Parabolic, and so on. All these shapes have to be defined (by the programmer) with his geometrical equation typically quite complicated.

Once the rays are defined, everyone with its direction and position in the space, it could be traced up to meet the following mirror surface. Practically, the only equation to solve is the intersection between a line (the ray path) and a geometrical function describing the optical surface of the mirror. At the intersection point, one should calculate the normal at the optical surface, and reflect the ray respect it. In this way the mirror, locally, can be approximated with a plane surface, and the result is just a simple reflection (easy to treat).

In this way, every aberration introduced by the optics, every error of focus will be shown in the final image obtained. It is easy to introduce slope errors (just modifying the geometrical equation describing the optical surface); it is easy to simulate misalignment (just moving the pole of the optical surface) and so on.

In reality, behind this simple concept of reflection, some complicate equations take into consideration the aberrations, the focal property and so on. However, instead of treat this as the “case of the mirrors”, we will treat as a simplification of the more general case of the grating.

The grating, as a prism or a crystal, is a dispersive object. We will consider only the grating. The case of the crystal will be discussed in another section of this school. The basic equations for gratings is:

$$(6) \quad d(\sin\alpha - \sin\beta) = n\lambda$$

Where the following reference system was adopted.

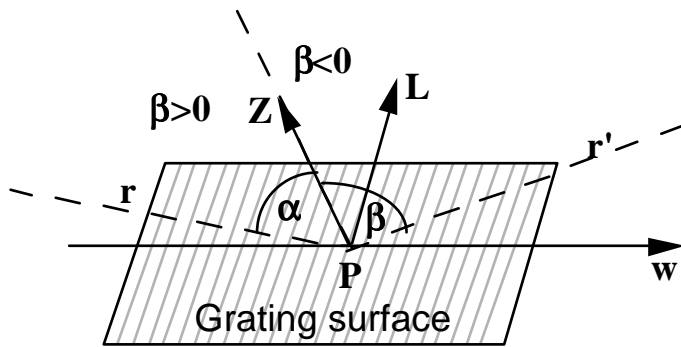

But, to have a deep knowledge of the property of a grating/mirror, the Fermat's principle must be applied. This principle, widely used in optics, can be summarised as follow: the light travels between two different points in the shortest possible time. Therefore, it is necessary to recover the optical path  $F$  of a ray passing trough a grating (the case of the mirror is a sub-case) and then derives this path respect the time  $t$ . The minimum time condition is fulfilled when:

$$(7) \quad \frac{\partial F}{\partial t} = 0$$

Any deviation from this condition can be called “aberration”, i.e. distortion from the ideal value.

To found the minimum time path is equal to found the minimum distance path, since the photon travels always in the same medium (i.e. vacuum). One must therefore define the optical path  $F$  of a ray passing trough a general point  $P$  (of co-ordinate  $w, k, l$ ) on the grating as a function of  $w, k$ , and  $l$  and found the minimum distance path respect to these co-ordinates. The general optical path can be written as:

$$(8) \quad F = \overline{AP} + \overline{PB} + \frac{n\lambda}{d}$$

Where the dispersive term is introduced to take into account the dispersive property of the grating.

The co-ordinate of the point  $A$  and  $B$  will be respectively  $(x, y, z$  and  $x', y', z')$  and thus the distance  $AP$  and  $PB$  could be re-written as follow:

$$(9) \quad \overline{AP} = \sqrt{(x - w)^2 + (y - k)^2 + (z - l)^2}$$

$$(10) \quad \overline{PB} = \sqrt{(x' - w)^2 + (y' - k)^2 + (z' - l)^2}$$

Now, the co-ordinate  $x, y$  and  $z$  (as  $x', y', z'$ ) can be re-written as a function of  $r$  (distance source-pole of the grating),  $r'$  (distance pole of the grating-image) and of the angles  $\alpha$  and  $\beta$ , i.e.:

$$(11) \quad x = -r \cdot \cos \alpha$$

$$(12) \quad y = r \cdot \sin \alpha$$

$$(13) \quad x' = r' \cos \beta$$

$$(14) \quad y' = r' \sin \beta$$

$$(15) \quad z' = -z \frac{r'}{r}$$

The last point to know is the relation between  $k$ ,  $w$  and  $l$ . Practically it is necessary to know the geometrical equation describing  $k$  as a function of  $w$  and  $l$ . This equation should be written in the following form:

$$(16) \quad k = \sum_{i,j} K_{ij} w^i l^j$$

Of course, this equation is different for the different geometrical shapes. Nevertheless, there is a case, the toroidal, which describe more than 90% of the cases of mirror and gratings (probably 100% of the gratings).

For this case, of a toroidal grating, this relation is:

$$(17) \quad k = \frac{1}{2R} w^2 + \frac{1}{2\rho} l^2 + \frac{1}{4R^2 \rho} w^2 l^2 + \frac{1}{8R^3} w^4 + \frac{1}{8\rho^3} l^4$$

Where  $R$  is the major radius of curvature of the toroidal shape and  $\rho$  the minor radius of curvature.

With the previous relations (8-15) it is easy to re-write the equation 8 as a polynomial series, still as a function of  $w$  and  $l$ , i.e.:

$$(18) \quad F = \sum_{i,j} F_{ij} w^i l^j$$

Each term of the equation 18 can be obtained from equation 8 simply by deriving it:

$$(19) \quad F_{i,j} = \frac{1}{(i+j)!} \left[ \frac{\partial^{(i+j)} F}{\partial w^i \partial l^j} \right]_{w,l=0}$$

In principle, one must satisfy the following two equations to found the “no aberration” condition for a grating:

$$(20) \quad \frac{\partial F}{\partial w} = 0 \quad ; \quad \frac{\partial F}{\partial l} = 0$$

Nevertheless, practically, this condition is more or less impossible to found for a general grating shape. The operative approach is to set independently to zero as much terms as possible of the equation 18. In this way, even if are not equal to zero, the equations 20 become small enough. The word «enough» depends on a lot of parameter, the shape, the divergence of the incoming radiation, the illuminated area of the grating and so on. For this reason is important to know the influence of each term on the final image shape, to set to zero the most important ones and minimise the others. For instance, the term  $F_{00}$  (which can be set at any value because its derivative respect to  $w$  and  $l$  is always zero) is simply the amount of path travelled ( $r+r'$ ).  $F_{10}$  takes into account the dispersive property of the grating, i.e. the equation 6.

The high order terms, vice-versa, describe the focal property as the residual aberration introduced by the optical component.

Let us consider, for instance, the terms  $F_{20}$ . This term is the second derivative of the optical path function  $F$ , i.e. from equation 19:

$$(21) \quad F_{2,0} = \frac{1}{2} \left[ \frac{\partial^2 F}{\partial w^2} \right]_{w,l=0}$$

Since the first derivative is zero (as a boundary condition to have diffraction), this term is an indicator of how much the optical path function differs from zero moving out from the ideal working condition, i.e. out from the centre of the grating. If this term is set to zero, this means that every ray, even if it does not hit the grating in its pole, still satisfies the minimum time path (at least in the second order approximation). This is exactly the focal condition of an object, i.e. the main term that contributes to the presence or not of aberration.

The same consideration can be made for the term  $F_{02}$ . Nevertheless, as  $F_{20}$  describes the focal condition in the ‘‘tangential plane’’ (the plane defined by the outgoing ray and the normal to the grating surface), the term  $F_{20}$  describes the focal condition in the orthogonal plane, the sagittal one (described by the outgoing radiation direction and the groove direction (for a grating)).

Let us see the form of these terms, always in the case of a toroidal grating:

$$(22) \quad F_{2,0} = \left( \frac{\cos^2 \alpha}{r} - \frac{\cos \alpha}{R} \right) + \left( \frac{\cos^2 \beta}{r'} - \frac{\cos \beta}{R} \right)$$

$$(23) \quad F_{0,2} = \frac{1}{r} + \frac{1}{r'} - \frac{\cos \alpha - \cos \beta}{\rho}$$

The further terms will describe the residual (or absence of) aberrations. Of course higher is the order of the aberration lower is the influence of this on the final image. So, for practical reasons, only the term  $F_{30}$  will be considered.

$$(24) \quad F_{3,0} = \left( \frac{\cos^2 \alpha}{r} - \frac{\cos \alpha}{R} \right) \frac{\sin \alpha}{r} + \left( \frac{\cos^2 \beta}{r'} - \frac{\cos \beta}{R} \right) \frac{\sin \beta}{r'}$$

Let us now see how we can estimate the effect of these terms in the final image. As explained above, the optical path function describes the optical characteristics of the final image. So, with the knowledge of the terms  $F_{i,j}$ , one can write the optical path function as a function of  $w$  and  $l$ , when  $w$  and  $l$  are, this time, the half dimension of the photon spot on the grating surface. This will give an estimation of the contribution to the final image of the most distant rays from the pole of the grating, i.e. the rays that mostly contribute to the final imperfection of the image. Therefore,

$$(25) \quad \left[ \frac{\partial F}{\partial w} \right]_{w=l=0} \cdot W = \frac{3}{2} W^3 F_{30} + \dots$$

will give an idea of the enlargement of the final image due to the  $F_{30}$  contribution. The aberration due to this term is called ‘‘primary coma’’. Typically, it is quite difficult or impossible to set to zero the term  $F_{30}$ . Therefore, one must try to minimise it considering that the equations 6 and 22 must be absolutely set to zero. Nevertheless, at the end, to have a more evident (and precise) view of the effect of the residual slope errors, ray tracing is the ideal solution.

Let us see now which information we can obtain. Other than the shape of the final image, another important information could be the number of rays lost or, alternatively the dimension of the optics required. In fact, one

can also have a look at the spot on the mirror surface. If one wants to have a particular divergence accepted by the beamline, one should have the optics big enough to accept it. Very important is also the resolving power of a beamline. There are different methods to estimate it. Let us consider two.

In the first case, one can define a source with an energy distribution made by two single lines. The source will pass the optics, (mirrors and the grating) and arrive in the plane where there will be the exit slit. Evidently the two lines are *resolved* when are visible and the resolving power will be defined by the energy separation between the two lines, i.e. as in the following picture:

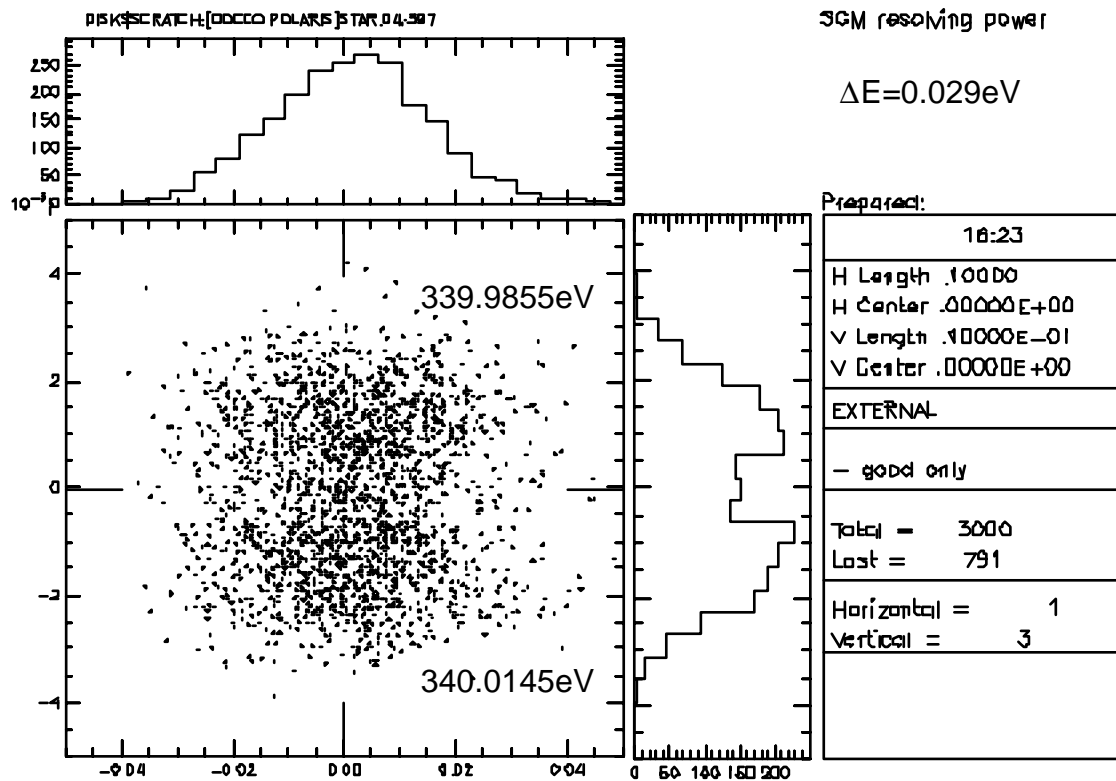

In this case, the resolving power will be 12000 ( $340/0.029$ ) with an exit slit of  $20 \mu\text{m}$  (the separation between centre of the two image, i.e. the dimension of the monochromatic spot).

A different approach can be adopted introducing a real exit slit. The source now should be defined as a continuous energy distribution. In particular, one should define an energy interval great enough to have an energy distribution well defined after the exit slit, but small enough not to lose too many rays at the slit. One should now be able to plot the energy distribution after the slit and the result, for the same system above is:

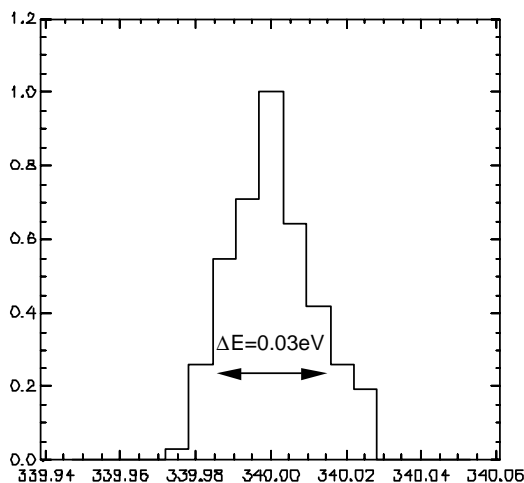

Another information that one can obtain is the effect of the slope errors on the focal property of an element. One can introduce the slope errors in one or more optical elements and compare the result with the ideal case. Alternatively, one can simulate different mirror shapes to find the best solution for his purpose.

## Two examples

### 1) Demagnification with a single mirror

In the first example, let us consider the case of the demagnification of a square source ( $50 \times 50 \mu\text{m}^2$ ). We will use a single mirror, focusing only in the vertical direction. There are numerous possible choices. We will limit at the cases of spherical, cylindrical and elliptical mirror.

The divergence of the source is  $0.5 \times 0.5$  mrad. This is a typical value for a synchrotron radiation beamline. The idea is to create a  $10 \mu\text{m}$  vertical dimension spot. Another constrain is the incidence angle. Above  $2^\circ$  grazing incidence ( $88^\circ$  normal) the reflectivity drops down rapidly. Therefore,  $2^\circ$  will be our choice.

The Program used is SHADOW, later described. In the first case, the mirror is spherical; the radius (that can be calculated by the program) is defined by the equation

$$(26) \quad \left( \frac{1}{r} + \frac{1}{r'} \right) \frac{\cos \vartheta}{2} = \frac{1}{R}$$

Where the angle  $\theta$  is respect to the normal to the surface.

In this case  $r=500\text{cm}$ ,  $r'=100\text{cm}$  and  $R=4775\text{cm}$ . A demagnification 5:1 should give us a  $10\mu\text{m}$  vertical dimension, but the result is the following:

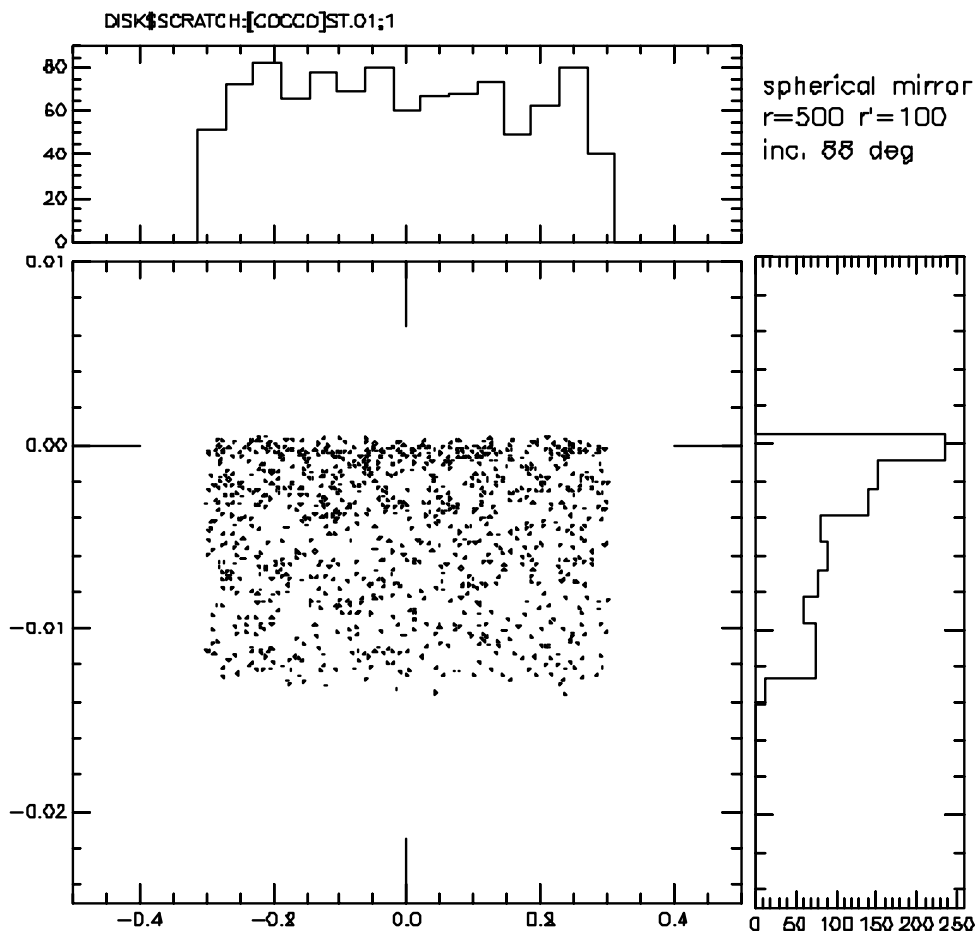



The units are cm. As can be seen, the final spot is not a stripe of 10  $\mu\text{m}$  but has a big tail due to a lot of aberration, induced by the combination of the strong demagnification and the high divergence of the beam.

The second case is identical to the first except for the distances that are doubled, i.e.  $r=1000\text{cm}$   $r'=200\text{cm}$ . The final image is:

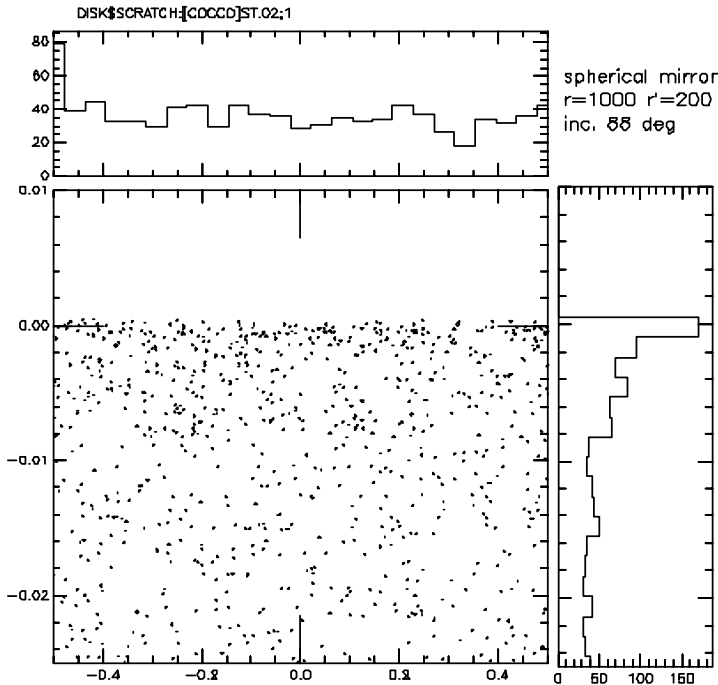

The width of the graph is always the same. It is evident that there is an enlargement of the tail. This is due to the increasing of the lightened part of the mirror, i.e. the parameter  $W$  of the aberration theory. As explained the aberration is proportional to the same power of  $W$  and this explain the enlargement of the image aberration.

The third case is no more a 5:1 demagnification but a 3:1. Even in this case we will use a spherical mirror but with  $r=600$ ,  $r'=200$ . The expected image height is about 15  $\mu\text{m}$ , but, considering the reduced demagnification, i.e. the reduction of aberrations, the result is better than the first case. The spot become:

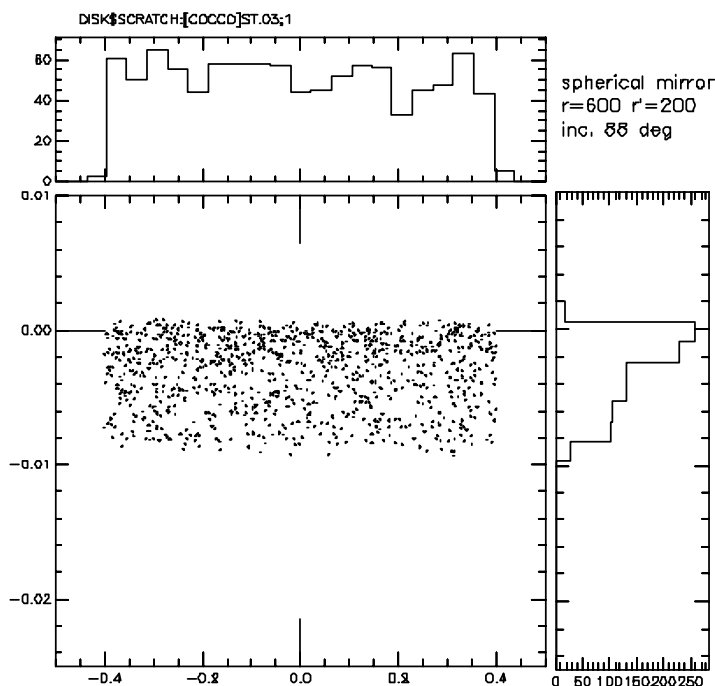

Up to now, the mirror(s) was placed with the reflecting surface faced up, i.e. in tangential focusing mode (see next picture). Now, let us consider a sagittal cylinder. This is a cylinder with the reflecting surface face left (or right) focusing still in the vertical direction (see figure).

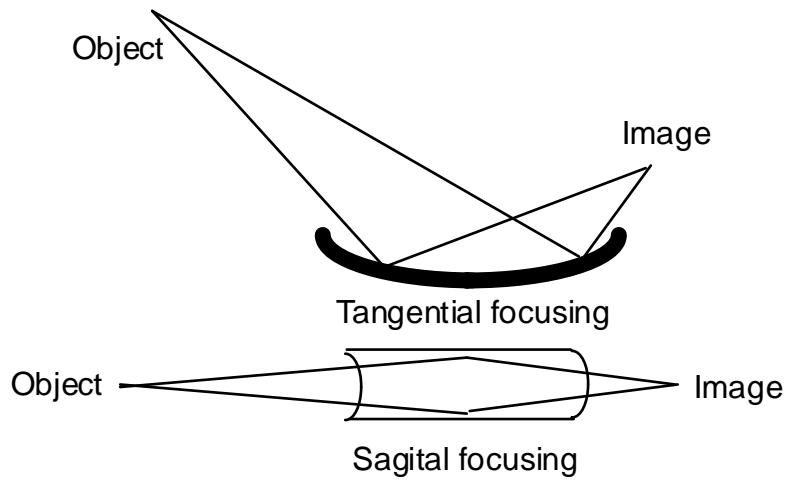

From the geometrical theory of aberration it comes out that there is an enlargement of the final spot dimension. Always considering an entrance arm  $r=500$  cm and  $r'=100$ , with the radius of curvature  $\rho$  calculated (from eq. 23) as:

$$(27) \quad \left(\frac{1}{r} + \frac{1}{r'}\right) \frac{1}{2 \cos \vartheta} = \frac{1}{\rho}$$

The final image will be:

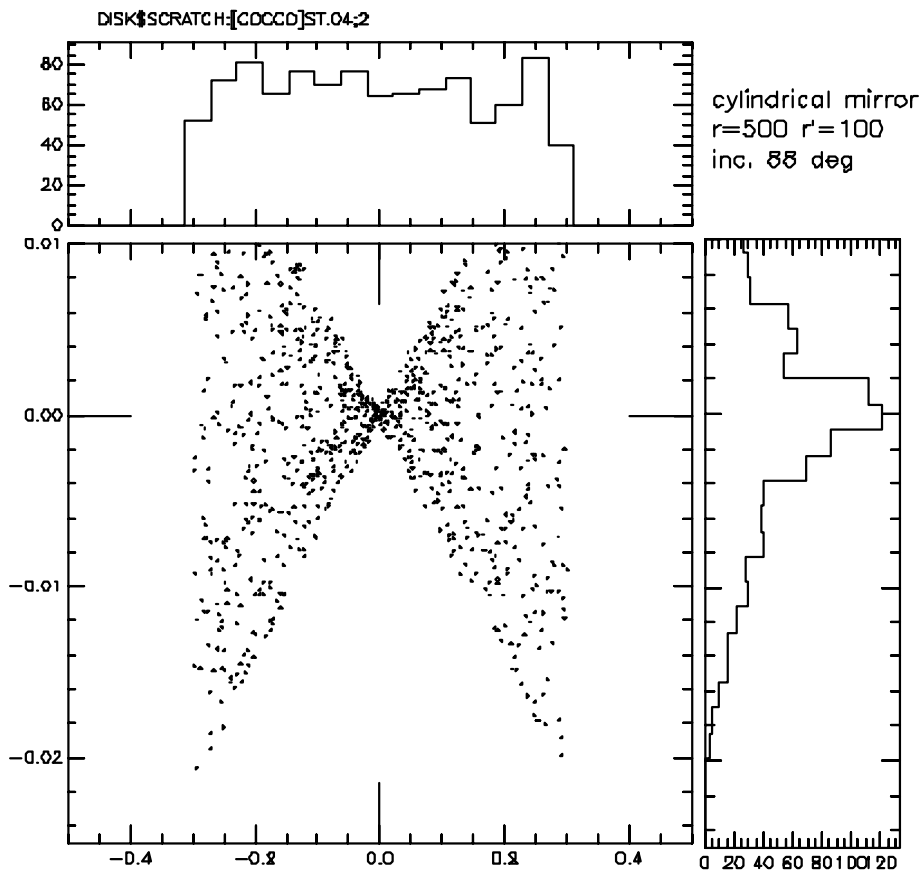

The final case is the case of a plane-elliptical mirror. This is a mirror with elliptical shape in the tangential direction and plane in the sagittal. This still focus in tangential direction and the great advantage is the absence of aberration due to the length of the spot. This is because the ellipsoid always focuses a point in a point even if the divergence is quite large. Of course, this is true if the aberrations? are not considered. Without aberrations the final image is:

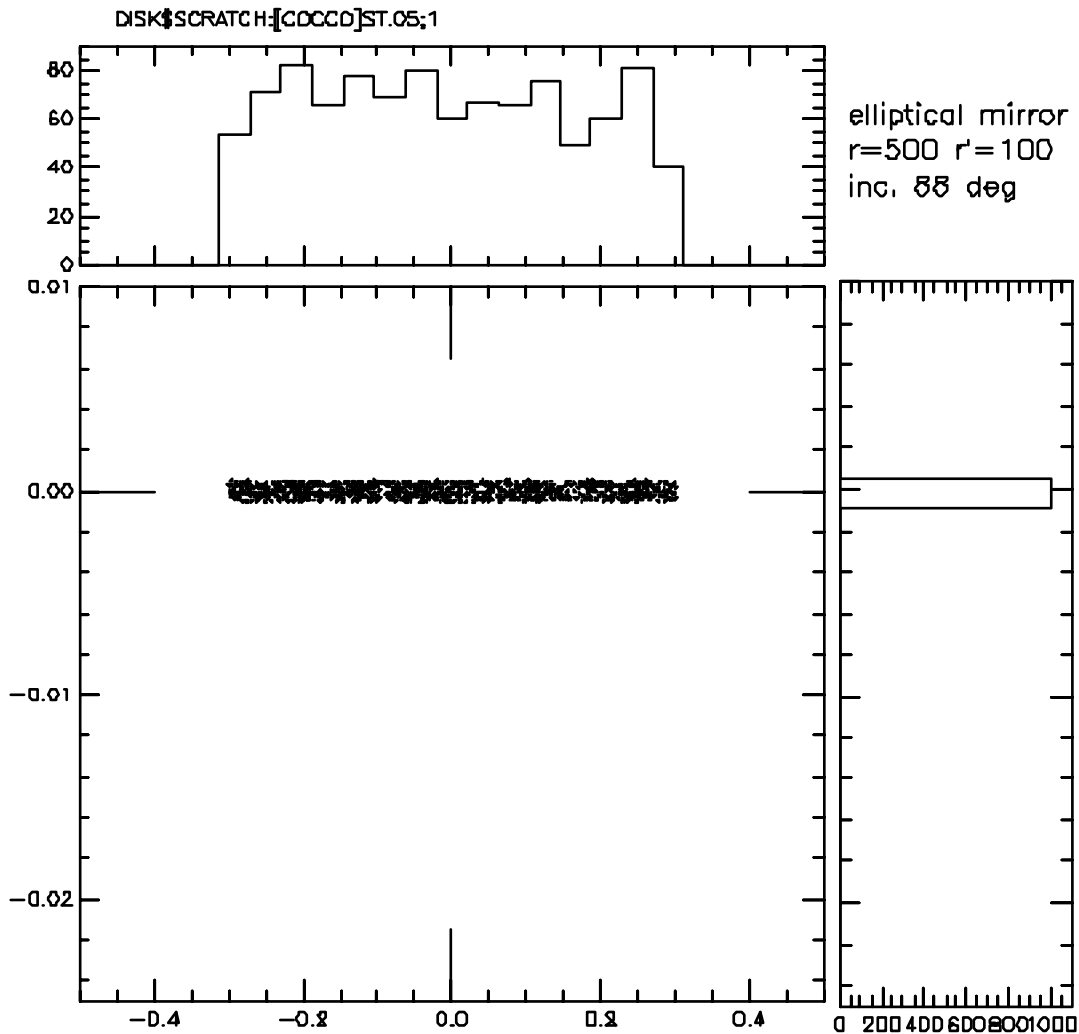

Therefore, in principle, the elliptical shape is the best choice.

## 2) Spherical grating

This second example will introduce the use of the program SHADOW. We will consider a spherical grating again working in tangential mode. The grating will have a radius of curvature  $R=2000$  cm. The groove density is 6000 l/cm, the distance source grating is 400 cm and the distance grating-image (grating-exit slit) is 150 cm.

By satisfying eq. 22, i.e.  $F_{20}=0$  a table of energy and angle of the grating is:

Photon energy (eV)	Incident angle	Diffraction angle
500	83.04834	83.79230
300	82.63818	83.84556
100	80.94452	84.25400
50	79.01137	85.23461

In this case, we are working with the external orders, for SHADOW the positives.

Before creating the grating, we must create the source. Both source and optical elements must be create in window mode.

The source must be described carefully, trying to avoid forgetting some parameters. We will simulate a source of  $240 \times 10 \mu\text{m}^2$  (see the first of the 3 figures appended to this notes).

The energy distribution should be a multi-line or continuous introducing an exit slit to define the resolution. Once all the parameters are defined, we can define the optical element, the grating.

We use now the photon energy of 100 eV. Even in this case, the window mode is quite easy to be used. One must insert the right parameter, in the main menu and in the sub menu. Once everything is defined, the program should trace the rays (processing the data) and to visualise the results is possible to use both the internal plot system (pressing on the button plot) or using the post-processor (under the menu tools).

Briefly, SHADOW defines as **STAR.XX** the image of the element XX (01,02 etc...). The image in the mirror surface is defined as: **MIRR.XX** and, if a screen is defined, the image on the screen is **SCREEN.XXYY** where XX is related to the optical element on which the screen is appended and YY is the number of the screen. Vice-versa the source is recorded in the file **BEGIN.DAT**.

The post-processors are sub-programs useful to analyse the data. They work in prompt mode; i.e. an answer is expected for any question the program formulates. In particular, **histo1** generate a histogram to see the mono-dimensional distribution of photons (in space or energy). Remember that the columns for SHADOW are defined as follow:

1	X
2	Y
3	Z
4	X'
5	Y'
6	Z'
11	Energy

In addition, the reference system is the following:

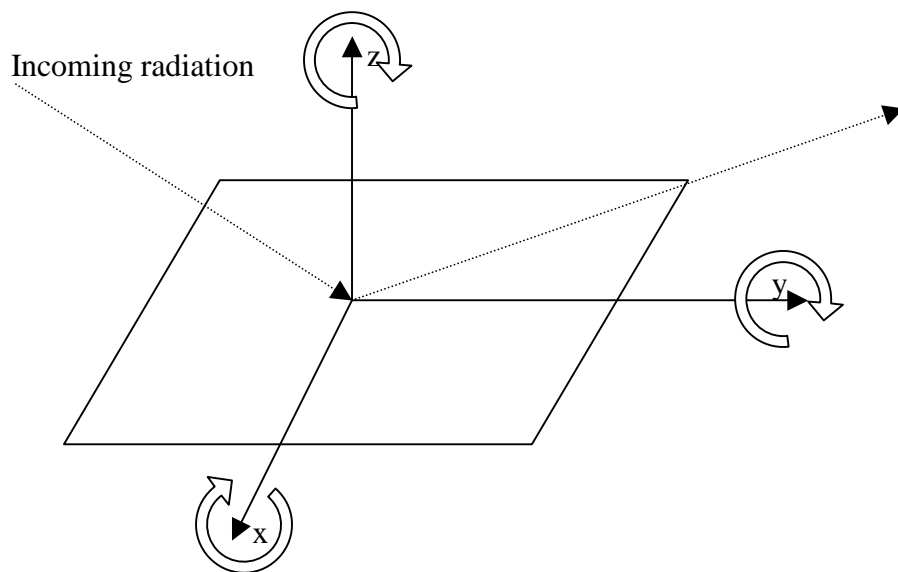

The last exercise is a "complete" soft X-ray beamline.

The beamline is described as follows:

Prefocusing: Kirkpatrick-Baez System

Monochromator: Rowland circle Spherical Grating

### Top View

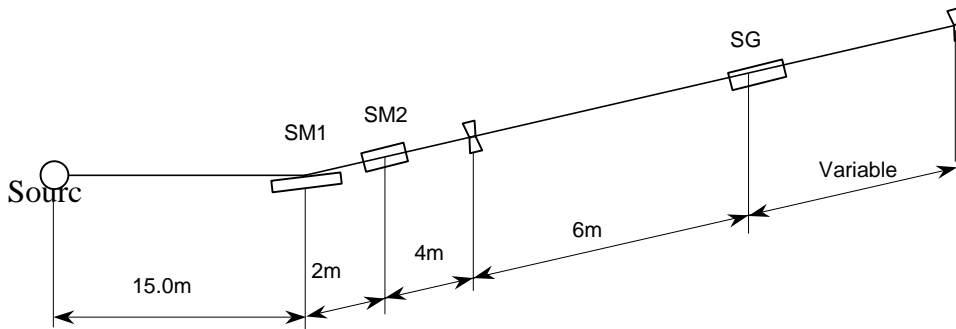

Source: Spatial Gaussian (240 $\mu$ m horiz. 40  $\mu$ m Vertical) Angular: Uniform (0.1 X 0.1 mrad)

SM1 Tilt 90° Incidence angle 88° r=15m r'=6m

SM2 Tilt 90° with respect to SM1 Incidence angle 88° r=17m r'=4m

Both focus on entrance slit

Formulae to use:  $(1/r+1/r') \cos(\theta)/2=1/R$

Spherical Grating

SG: r=6m r'= to be found groove density: 12000 l/cm  $\alpha=86^\circ$  (fixed)

To be calculated: R,  $\beta$ , r'

R from F20:  $\cos\alpha/r-1/R=0$

$\beta$  from grating equation (choose 650<energy<2000 eV)  $n\lambda/d=\sin\alpha-\sin\beta$

Note:  $\lambda(\text{\AA})=12398.52/\text{Energy(eV)}$ ,  $d=1/\text{groove density}$

r' from F20:  $\cos\beta/r'=1/R$

Important: The diffraction orders in Shadow are opposite with respect to this formula

Calculate

- 1) the spot dimension in the entrance slit
- 2) the spot dimension after the spherical grating (at the exit slit)
- 3) the resolving power at the selected energy.

In principle, one can use both the positive and negative orders. The use of positive order (in the formula) produces an enlargement of the image and therefore a reduction of the resolving power.

### Two Crystals I

The main purpose of this section is to demonstrate how to ray-trace a crystal monochromator. SHADOW needs a data file to ray trace a crystal. This file is prepared by BRAGG. In addition, BRAGG may allow the user to visualize the diffraction patterns or rocking curves of the crystal in consideration. SHADOW deals with crystals in both reflection (Bragg) and transmission (Laue) mounting. Two crystal models are allowed in SHADOW: perfect crystals (i.e. Silicon, Diamond) and mosaic crystals, where the crystal block is made by an agglutination of small microcrystals (i.e. graphite, beryllium). Perfect crystals may be symmetric (the Bragg planes are parallel to the crystal surface in Bragg mounting, and perpendicular in Laue mounting) and asymmetric, when the crystal planes form an arbitrary angle  $\alpha$  with the crystal surface. Mosaic crystals can only be symmetrical in SHADOW.

Ground-bent crystals (the so-called Johansson geometry) for perfect crystals are also allowed in SHADOW.

We remind the reader that a symmetric perfect crystal in Bragg mounting is essentially a mirror with a very narrow bandwidth in energy or angle, determined by its rocking curve or diffraction pattern. An asymmetric crystal does not act as a mirror, but as a grating, where the "grating ruling" is provided by the intersection lines

between the Bragg planes and crystal surface. In addition, the rocking curve determines the energy or angular acceptance, as in symmetric crystals.

In all the crystal cases of three-dimensional Bragg scattering, only the rays close to the Bragg condition will be diffracted; the other ones will be *absorbed* by the crystal. For this reason, to only look at the scatter plot of the reflected (outgoing) beam, like we did in the case of the grating, is not enough. This is because of the way SHADOW carries the intensity information; to each ray is associated the vector potential **A** that contains, in its modulus, the intensity (and polarization) information. For this reason a simple scatter plot does not convey any information on the *intensity* of the rays; it is necessary then to use either the facilities provided by PLOTXY in the CONTOUR mode (two dimensional case), or make use of the INTENSITY flag in PREPLOT (one dimensional case). Since PLOTXY has already been demonstrated, we will concentrate on PREPLOT. In this example we will then show how to:

- To use BRAGG in generating the files needed by SHADOW to perform the calculations.
- To run SHADOW for the CRYSTAL case
- To run SHADOW by restarting from an Optical Element instead than from a source
- To use PREPLOT in order to analyze the results

The case that we will consider is that of a two-crystal monochromator in an antiparallel configuration. After considering the ideal case, we will introduce some rotational misalignment and study its effect on the transmitted spectrum. See figure 1 below.

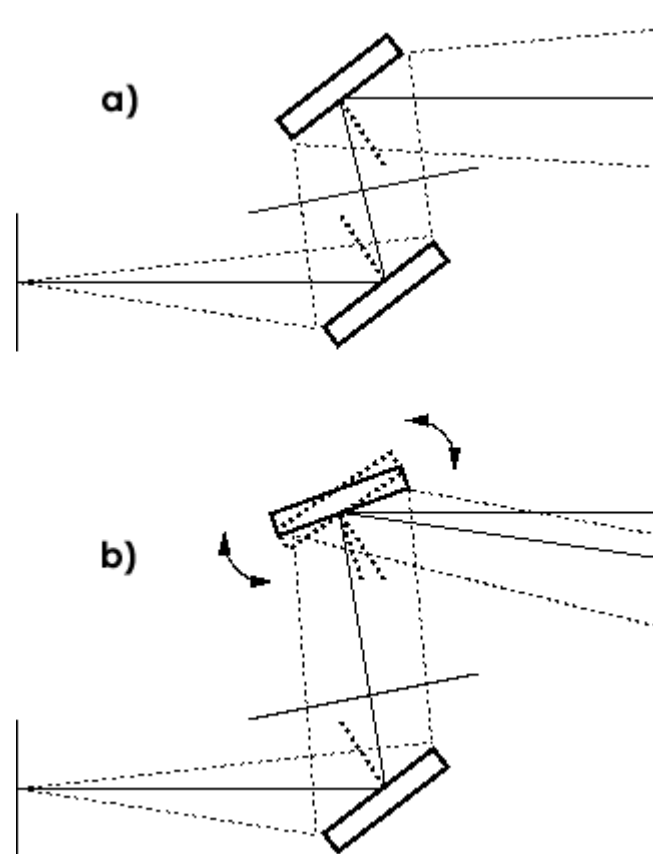

Fig. 1 - Two-crystal monochromator with diverging radiation and antiparallel configuration:  
a) ideal case, b) misaligned second crystal

In order to do that, we will restart the calculations at the second OE, since the first one will have been left unchanged. The source that we will be using will be a point source of single wavelength. The BRAGG condition

$$n \lambda = 2 d \sin \theta$$

will change along the crystal surface, since  $\theta$  will be changing and rays hitting at different positions will be attenuated by different amounts.

Another section will describe the complementary case of a collimated broad-band source. Notice that for a real source, i.e., both diverging and with a continuous distribution, the output from Preplot will not be a "nice"

curve but instead a *band* of values. To analyze it it will be necessary to resort to HISTO1, as shown in the previous section on the radiation power density study.

In order to prepare BRAGG it is necessary to have a table of the real part of the atomic scattering coefficients in function of  $\sin(\theta)/\lambda$ . An exhaustive table can be found in the International Tables of X-Ray Crystallography, Vol.III, Sect.2.2, Table 2.2A, p.72. A shorter version can be found in *X-ray Diffraction*, by B.E.Warren, Addison-Wesley. BRAGG will prompt about the coefficients.

BRAGG is the program that generates the crystal parameters in a format suitable for input to SHADOW. Let us use the GaAs (111) plane, with incident energy of 11160 eV.

\$ **BRAGG**

All crystal structures are referred to a cubic unit cell.

Bravais lattice type :

0 for ZincBlende

1 for Rocksalt

2 for simple FCC

3 for CsCl structure

Hexagonal Bravais lattice type:

4 for Hexagonal Close-Packed structure

5 for Hexagonal Graphite structure

Then ? **0**

Lattice constant (Angs) ? **5.65**

Index of crystal plane of reflection H,K,L : **1,1,1**

```
*****
The ZINCBLLENDE structure is defined by atom A located at
(0,0,0) and atom B at (1/4,1/4,1/4) of the fcc lattice.
*****
```

Enter 2-letters (capitalized) atomic symbol for atom A : **GA**

Enter 2-letters (capitalized) atomic symbol for atom B : **AS**

```
*****
Atomic scattering factor is defined by fo + f' + if", where
fo = fo(SIN(theta)/Lambda) is the non-dispersive part
f', f" (Lambda) are the dispersive part.
*****
```

We need fo at 3 different values of SIN(theta)/Lambda, which should cover the range of interest and center around :

SIN(theta)/Lambda = 0.1532788325282192 ratio.

```
*****
```

Please enter 1) SIN(theta)/Lambda, 2) fo ,

\ At this point, take the International Tables or the ones from Warren, and

\ find the values tabulated for Ga and As at values of Sin(theta)/lambda

\ bracketing the one quoted above. BRAGG will automatically interpolate.

For atom A, first set : **0.14, 27.162**

., second set : **0.15, 26.783**

., third set : **0.16, 26.406**

For atom B, first set : **0.14, 28.742**

., second set : **0.15, 26.783**

., third set : **0.16, 27.877**

```
*****
f', f" is furnished from optical constant library within ...
```

\ The other part of the atomic scattering factors is read from the library.

\ Enter the photon energy range, keeping it reasonably narrow.

minimum photon energy (eV) : **11100**

maximum photon energy (eV) : **11200**

energy step (eV) : **10**

Do you want to include crystal absorption [1/0] ? **1**

Temperature (Debye-Waller) factor : **0.979**

This is the value of the Debye-Waller coefficient,  $\exp(-1/2 \mathbf{G}^2 \mathbf{u}^2)$  where  $\mathbf{G}$  is the scattering vector and  $\mathbf{u}$  the rms atomic displacement. If in doubt, enter 1.0. This will ignore then DW effects.

Output file name (for SHADOW) : **GAAS.PAR**

Do you want to generate a rocking curve [1/0] ? **1**

What do you want to calculate ?:

[1] Diffracted beam in Transmission (Laue) geometry

[2] Diffracted beam in Reflection (Bragg) geometry

[3] like [2] using thick crystal approximation

<? **3**

... at what energy (eV) ? **11160**

So far, we are working with:

```

Lambda = 1.110978494623656 Angstroms
Theta (graz) = 9.804650841199757 degrees
Bragg angle = 9.807153296220226 degrees
Structure factor = (142.6426218594671,11.03752285669588)
Refraction index = 1 - delta - i*beta :
    delta = 7.3270650274570581E-06
    beta = 4.8385681505652676E-07
Absorption coeff = 547.2944878508624 cm-1

```

Do you want to calculate a mosaic crystal ? **0**

Do you want an asymmetrical cut [1/0] ? **0**

Real(Ss) : 25.541823566710784 microradians

Real(Sp) : 24.060473952622004 microradians

\ Ss and Sp represent the width of the Bragg peak, and will be used as  
 \ 'reduced units' in some of the plots, so that the peak will extend  
 \ from -1 to +1.

+/- how many microradians : **60**

How many points : **200**

Do you want to use sec [1/0] ? **0**

Do you want the R.C. not centered [1/0] ? **0**

Do you want to try another energy [1/0] ? **0**

\$

**VMS**

\$

**\$ DIR**

Directory D13:[XRAYOP.XTAL]

```

GAAS.PAR;1      4      26-MAR-1987      14:17      (RWED,RWED,RE,RE)
ROCK_CURVE.P;1  20      26-MAR-1987      14:17      (RWED,RWED,RE,RE)
ROCK_CURVE.PAR;1  3      26-MAR-1987      14:17      (RWED,RWED,RE,RE)
ROCK_CURVE.S;1  20      26-MAR-1987      14:17      (RWED,RWED,RE,RE)

```

Total of 4 files, 47 blocks.

**UNIX**

**%ls -al**

```

-rw-r--r--  1 shadow      1789 Mar  9 15:23 gaas.par
-rw-r--r--  1 shadow      9800 Mar  9 15:27 rock_curve.p
-rw-r--r--  1 shadow     1051 Mar  9 15:27 rock_curve.par
-rw-r--r--  1 shadow      9800 Mar  9 15:27 rock_curve.s

```

GAAS.PAR will be the input parameter file to SHADOW. At the end of the file GAAS.PAR is a table of: eV f'(Ga) f''(Ga) f'(As) f''(As) which form the optical constant library. The user can edit this file if more accurate values are available, especially near an absorption edge.

**\$ TYPE GAAS.PAR**

```

      0 1562378464.990918      3.2620290209213856E-08
      31      33 0.9790000000000000
(4.000000000000000,-6.8654264713317982E-17)
(4.000000000000000,6.8654264713317982E-17)
(8.4736075498395345E-17,-4.000000000000000)
(8.4736075498395345E-17,4.000000000000000)
      32.67800000000011      -40.80000000000018      10.00000000000364
      35.35699999999986      -50.74999999999727      24.99999999999272
      11
11100.000000000000      -1.895109680624937      3.414937245198015

```



|                    |                    |                   |
|--------------------|--------------------|-------------------|
| -2.436850441775594 | 0.5607204097485073 |                   |
| 11110.000000000000 | -1.880106255382257 | 3.410127243375178 |
| -2.449320912049193 | 0.5598036778163483 |                   |
| 11120.000000000000 | -1.865102830139578 | 3.405317241552341 |
| -2.461791382322792 | 0.5588869458841894 |                   |
| 11130.000000000000 | -1.850099404896898 | 3.400507239729505 |
| -2.474261852596391 | 0.5579702139520304 |                   |
| 11140.000000000000 | -1.835095979654219 | 3.395697237906668 |
| -2.486732322869990 | 0.5570534820198715 |                   |
| 11150.000000000000 | -1.820092554411540 | 3.390887236083831 |
| -2.499202793143589 | 0.5561367500877125 |                   |
| 11160.000000000000 | -1.805089129168860 | 3.386077234260994 |
| -2.511673263417189 | 0.5552200181555536 |                   |
| 11170.000000000000 | -1.790085703926181 | 3.381267232438158 |
| -2.524143733690788 | 0.5543032862233946 |                   |
| 11180.000000000000 | -1.775082278683501 | 3.376457230615321 |
| -2.536614203964387 | 0.5533865542912357 |                   |
| 11190.000000000000 | -1.760078853440822 | 3.371647228792484 |
| -2.549084674237986 | 0.5524698223590767 |                   |
| 11200.000000000000 | -1.745075428198142 | 3.366837226969648 |
| -2.561555144511585 | 0.5515530904269178 |                   |

ROCK\_CURVE.PAR lists the parameters used to generate the rocking curve at 11160 eV, which are a function of the real part of Ss and Sp (for the S- and P-polarization). For this case, Ss = 25.541 and Sp = 24.060 microradians.

#### \$ TYPE ROCK\_CURVE.PAR

```
ZincBlende structure :
For atom A, fo + f' + if" = (24.85407850869210,3.386077234260994)
      B,                    = (25.65378599830614,0.5552200181555536)
Lattice constant =      5.650000000000000      Angstroms
d-spacing        =      3.262029020921386      Angstroms
Photon energy    =      11160.00000000000      eV
Lambda          =      1.110978494623656      Angstroms
Theta (graz)    =      9.804650841199757      degrees
Bragg angle     =      9.807153296220226      degrees
SIN(theta)/Lambda = 0.1532788325282192      ratio.
Refraction index = 1 - delta - i*beta :
      delta =      7.3270650274570581E-06
      beta  =      4.8385681505652676E-07
Absorption coeff =      547.2944878508624      cm-1
Temperature factor = 0.9790000000000000
Structure factor F(000) = (238.7329504296558,15.76518900966619)
Structure factor F(hkl) = (142.6426218594671,11.03752285669588)
Real(Ss) : 25.541823566710784 microradians
Real(Sp) : 24.060473952622004 microradians
```

NOW we can run SHADOW (finally). To check things out, let us use a monochromatic source with only vertical divergence.

#### \$ GO SOURCE

```
SOURCE selected. Begin procedure.
This procedure generates a SOURCE for SHADOW.
Mode selected [ ? <ret for HELP ] ? : prompt
Call to INPUT
----- S H A D O W ----- May 1993
F.Cerrina CXrL/ECE - UW
Defining source :
When prompted for a yes/no answer, you may enter:
for YES  answer  Y, 1
for NO   answer  anything else
Do you want a verbose [ 1 ] or terse [ 0 ] output ? 0

----- SOURCE SPECS -----
Source modelling type [ 0-5 ] ? 0
How many rays [ 1 - 5 000 ] ? 1000
Seed [ odd, 1000 - 1 000 000 ] ? 12345
```

Do you want to optimize the source ? **0**

Source type : [ 0 ] regular source  
              [ 1 ] normal wiggler  
              [ 2 ] undulator  
              [ 3 ] elliptical wiggler

Then ? **0**

X-Z plane source type [ 0-3 ] ? **0**

Source Depth [ 1-4 ] ? **1**

Source Angle Distribution [ 1-6 ] ? **2**

Horizontal half-divergence [ (+)x, rads ] ? **0**

. [ (-)x, rads ] ? **0**

Vertical [ (+)z, rads ] ? **60E-6**

. [ (-)z, rads ] ? **60E-6**

Do you want a Photon energy [ Y/N ] ? **1**

Energy distribution [ 1-3 ] ? **1**

Photon Energy [ 0 ] or Angstroms [ 1 ] ? **0**

Energy [ eV ] ? **11160**

Do you want to store the optical paths (OPD) [Y/N] ? **0**

Do you want to generate the A vectors (electric field) [Y/N] ? **0**

```
Exit from INPUT_SOURCE
Generated          250 rays out of          1000
                   500
                   750
                   1000
```

```
Exit from SOURCE
SOURCE = Source has been successfully generated.
SOURCE procedure completed.
```

Shadow:: **trace**

Ray Tracing Selected. Begin procedure.

Mode selected [ ? <ret for HELP ] ? : **prompt**

PROMPT selected.

Call to RESET

Exit from RESET

Mode selected is:

PROMPT

Options:       to start anew [ 0 ]  
              to restart from a given OE [ 1 ]

Then ? **0**

Call to INPUT\_OE

----- S H A D O W ----- May 1993

F.Cerrina CXrL/ECE - UW

When prompted for a yes/no answer, you may enter: for YES answer Y, 1 for NO answer anything else

Defining Optical Element: 1 Continue ? [ ^Z or %EXIT to terminate OS ] <ret

Do you want a verbose [ 1 ] or terse [ 0 ] output ? **0**

You may save disk space by not writing out the intermediate STAR or MIRR data files. In general you will not need them unless you have specific needs (footprints, etc.)

Files to write out. Options:

All..... [ 0 ]  
Mirror only.....[ 1 ]  
Image at CP only.....[ 2 ]  
None.....[ 3 ]

Then ? **0**

Optical Element definition:

Incidence Angle ? **10**

Source Distance ? **5000**

Reflection Angle? **10**

Image Distance ? **150**

// The angles here do not matter, as they will be replaced by the exact

```

// Bragg angle when you choose autotuning of the crystal and neither do
// distances.
Reflector [ 0 ] or refractor [ 1 ] ? 0
A: Is this a Kumakhov system? 0
A: Is this mirror faceted [Y/N] ? 0
Mirror surface [ 1-9 ] ? 5
Is the mirror Cylindrical ? 0
Is this optical element a Fresnel Zone Plate ? 0
Are we dealing with a Grating ? 0
Are we dealing with a crystal [ Y/N ] ? 1

\ After we specify the mirror to be a crystal, SHADOW asks further
questions
\ to define the problem. We will tell the program that we want the
crystal to
\ be automatically set at the photon energy of 11160 eV.
File containing crystal parameters ? GAAS.PAR
Is it a mosaic crystal [ Y/N ] ? 0
Is the crystal asymmetric [ Y/N ] ? 0
Are we working in Johansson geometry [Y/N] ? 0
Automatic Tuning of Crystal [ Y/N ] ? 1
Energy, in eV, [ 0 ] or wavelength, in Angs., [ 1 ] ? 0
Photon Energy ? 11160
Is the mirror convex [ Y/N ] ? 0
Reflectivity mode [ 0,1,2 ] ? 0
Orientation Angle [ Alpha ] ? 0
Mirror Dimensions finite [ Y/N ] ? 0
Do you want to move the Source [ Y/N ] ? 0
Do you want to move the mirror itself [ Y/N ] ? 0
Distorted surface [ Y/N ] ? 0
Do you want to include surface roughness [Y/N] ? 0
Any screens in this OE [ Y/N ] ? 0
Slit at continuation plane [ Y/N ] ? 0
Extra Image plates [ Y/N ] ? 0
File containing the source array ? BEGIN.DAT
  Exit from INPUT
  Tracing optical element #           1
  Call to SETSOUR
  .....
  Exit from RESET
Call to INPUT_OE
----- S H A D O W ----- May 1993
F.Cerrina CXrL/ECE - UW
Defining Optical Element: 2 Continue ? [ ^Z or %EXIT to terminate OS ] <ret
Do you want a verbose [ 1 ] or terse [ 0 ] output ? 0
You may save disk space by not writing out the intermediate STAR or MIRR
data files. In general you will not need them unless you have specific
needs (footprints, etc.)
Files to write out. Options:
All..... [ 0 ]
Mirror only.....[ 1 ]
Image at CP only.....[ 2 ]
None.....[ 3 ]
Then ? 0

Optical Element definition:
Incidence Angle ? 10
Source Distance ? 150
Reflection Angle? 10
Image Distance ? 5000
Reflector [ 0 ] or refractor [ 1 ] ? 0
A: Is this a Kumakhov system? 0
A: Is this mirror faceted [Y/N] ? 0
Mirror surface [ 1-9 ] ? 5

```



```

drwxr-sr-x  4 shadow          512 Mar  9 14:58 ..
-rw-rw-r--  1 shadow       104020 Jun 10 12:10 begin.dat
-rw-rw-r--  1 shadow          371 Jun 10 12:41 effic.01
-rw-rw-r--  1 shadow          371 Jun 10 12:41 effic.02
-rw-rw-r--  1 shadow         1498 Jun 10 12:10 end.00
-rw-rw-r--  1 shadow         4540 Jun 10 12:41 end.01
-rw-rw-r--  1 shadow         4555 Jun 10 12:41 end.02
-rw-r--r--  1 shadow         1485 Jun 10 10:20 gaas.par
-rw-rw-r--  1 shadow       104020 Jun 10 12:41 mirr.01
-rw-rw-r--  1 shadow       104020 Jun 10 12:41 mirr.02
-rw-rw-r--  1 shadow          297 Jun 10 12:41 optax.01
-rw-rw-r--  1 shadow          742 Jun 10 12:41 optax.02
-rw-rw-r--  1 shadow          103 Jun 10 11:31 rc.com
-rw-r--r--  1 shadow         9080 Jun 10 10:21 rock_curve.p
-rw-r--r--  1 shadow        1185 Jun 10 10:21 rock_curve.par
-rw-r--r--  1 shadow         9048 Jun 10 11:40 rock_curve.s
-rw-rw-r--  1 shadow       104020 Jun 10 12:41 star.01
-rw-rw-r--  1 shadow       104020 Jun 10 12:41 star.02
-rw-rw-r--  1 shadow         1493 Jun 10 12:10 start.00
-rw-rw-r--  1 shadow         4451 Jun 10 12:41 start.01
-rw-rw-r--  1 shadow         4466 Jun 10 12:41 start.02
-rw-rw-r--  1 shadow           30 Jun 10 12:41 systemfile.dat

```

Note the P-polarization has smaller average reflectivity, because of narrower width of the rocking curve (smaller value of  $S_p$  relative to  $S_s$ ).

### \$ ty effic.01

Of a total of 1000 rays, of which 1000 formed the input set  
0 were out of the mirror N. 1

The mirror collects 1.0000 of the incoming flux.

The average reflectivities are :

```

S-pol          0.37464
P-pol          0.35000
Total          0.36232

```

The overall efficiency of the mirror is : 0.36232

We know that SHADOW must have changed the optical system angles, in order to satisfy Bragg's equation. To check the new values, let us run MIRINFO.

### \$ mirinfo

```

----- M I R I N F O -----
vs. 3.0 - May 1993

```

MINFO Mirror descriptor file. It must be an END.xx type.

MINFO Please input filename: **end.01**

MINFO File read correctly.

MINFO Title ? **plane crystal reflection**

MINFO Comment ? **to test SHADOW computation of the rocking curve**

MINFO Output file ? **mirr.inf**

MINFO Prepare output to file : mirr.inf

// Notice the incident and reflected angle have been replaced by the  
// Bragg angle.

\$

\$

### \$ type mirr.inf

```

+++++
***** MIRROR DESCRIPTION *****
+++++
plane crystal reflection
to test SHADOW computation of the rocking curve.
+++++
Input file specified:end.01
Full file Specification
:D13:[XRAYOP.XTAL]END.01;1
Creation Date      :26-MAR-1987 14:41
+++++
Surface figure was defined as:      PLANE
Cylindrical figure                   NO
Element type                         REFLECTOR
Element type                         CRYSTAL

```

```

Lattice Spacing                3.2620290209213856E-08
Bragg Reflection from
GAAS.PAR
Reflectivity                    OFF
Mirror dimensions              UNLIMITED
+++++
Central Axis parameters :
Source Plane Distance          5000.000000000000
Image Plane                    150.000000000000
Incidence Angle                80.19284670377978
Reflection/Diffraction Angle  80.19284670377978
Mirror parameters              COMPUTED
Same configuration as Central Axis  NO
Objective focus at            0.0000000000000000E+00
Image focus at                0.0000000000000000E+00
Incidence angle               0.0000000000000000E+00

```

Parameters used follow:

```

Plane mirror
Source of this O.E. moved      NO
Mirror at pole position ( no mov. )  YES
+++++

```

Now let us verify that SHADOW also computes the same rocking curve. Since the source we used was a point source, the incidence angle changes continuously along the mirror surface, accordingly to the aperture of the ray from the central axis. If we then plot the ray intensity versus  $z'$ , i.e., the sine of the aperture at the image plane, we should obtain a curve that duplicates exactly the Bragg rocking curve. Let's compare the following plot with that done earlier using ROCK\_CURVE.S. We use PREPLOT to display the rocking curve and generate a plottable file.

\$  
\$

### \$ PREPLOT

PREPLOT Input file ? **star.01**

```

Read          1000 rays.
Each ray has   12 entries.

```

PREPLOT How many columns to write out ? **2**

```

Row [1-12] : the individual column
Row [20]  : R = SQRT(X**2 + Y**2 + Z**2)
Row [21]  : angle from the Y-axis
Row [22]  : the magnitude of A vector
Row [23]  : A**2

```

PREPLOT Row # 1 : **6**

PREPLOT 2 : **23**

```

Options - Enter
0   for excluding the losses
1   for including losses at a particular O.E.
2   for plotting all the rays .
3   for plotting ONLY the losses (all of them)
4   for plotting ONLY the losses at a given O.E.

```

PREPLOT Then ? **0**

### VMS

```

Output options :
[ 0 ] store rays in a file
[ 1 ] plot directly on screen
[ 2 ] both

```

Then ? **2**

PREPLOT Output file ? **STAR.01.PLT**

PREPLOT Terminal type: [0] VT240, [1] TEK 40xx, [2] HIREZ, [3] TEK 4107 : OOOOOOO

\*\*\*\*\*

```

Found          1000 good points out of          1000

```

### UNIX

Found 1000 good points out of 1000

Display type:

```

[ 0 ] Xwindow
[ 1 ] Tektronix
[ 2 ] Postscript file

```

Terminal type: **0**

The default filename is preplot.dat -- it is a good idea to change the name to something meaningful.

```
% mv preplot.dat star.01.dat
```

We will now create a plottable file of the intensity after the second crystal, but we will be plotting it out later. If you are interested, plot it now just as we did for STAR01.PLT. The Bragg curve should be sharper.

```
$ PREPLOT
```

```
PREPLOT Input file ? star.02
```

```
Read          1000 rays.
Each ray has   12 entries.
```

```
PREPLOT How many columns to write out ? 2
```

```
Row [1-12] : the individual column
Row  [20] : R = SQRT(X**2 + Y**2 + Z**2)
Row  [21] : angle from the Y-axis
Row  [22] : the magnitude of A vector
Row  [23] : A**2
```

```
PREPLOT Row # 1 : 6
```

```
PREPLOT 2 : 23
```

```
Options - Enter
```

```
0   for excluding the losses
1   for including losses at a particular O.E.
2   for plotting all the rays .
3   for plotting ONLY the losses (all of them)
4   for plotting ONLY the losses at a given O.E.
```

```
PREPLOT Then ? 0
```

```
VMS
```

```
Output options :
```

```
[ 0 ] store rays in a file
[ 1 ] plot directly on screen
[ 2 ] both
```

```
Then ? 0
```

```
PREPLOT Output file ? STAR.02.PLT
```

```
PREPLOT Terminal type: [0] VT240, [1] TEK 40xx, [2] HIREZ, [3] TEK 4107 : 1
```

```
*****
```

```
Found          1000 good points out of          1000
```

```
UNIX
```

```
Found 1000 good points out of 1000
```

```
Display type:
```

```
[ 0 ] Xwindow
[ 1 ] Tektronix
[ 2 ] Postscript file
```

```
Terminal type: 0
```

```
% mv preplot.dat star.02.dat
```

To illustrate the case of Bragg diffraction, we will now offset slightly the second crystal from its ideal position. At first, we will be setting directly (no autotuning or other features) the second crystal to the "wrong" angle, i.e.,  $2.777E-3$  degrees away from the nominal Bragg angle (that we know exactly from the run of MIRINFO). It is a good idea to create a new subdirectory for clarity. We will copy down the image of the first mirror and restart the calculation from the second optical element.

```
VMS
```

```
$
```

```
$ CREATE/DIRECTORY [.OFFSET]
```

```
$ SET DEF [.OFFSET]
```

```
$ COPY [-]STAR.01,GAAS.PAR [ ]
```

```
$ COPY [-]OPTAX.01 [ ]
```

```
UNIX
```

```
%
```

```
% mkdir offset
```

```
% cd offset
```

```
% cp ../star.01
```

```
% cp ../gaas.par
```

```
% cp ../optax.01
```

```
$ GO TRACE
```

```
Ray Tracing Selected. Begin procedure.
```





Call to INPUT\_OE  
----- S H A D O W ----- May 1993

F.Cerrina CXrL/ECE - UW

Defining Optical Element: 3 Continue ? [ ^Z or %EXIT to terminate OS ] ^Z

End of session

Procedure completed. Return to COMMAND level

Shadow:: **exit**

Exit to DCL

\$

\$

The tracing has been completed. Notice how easy it is to restart from any given point along the optical system.

We now generate another plottable file, similarly to what we did before.

## \$ PREPLOT

PREPLOT Input file ? **STAR.02**

Read 1000 rays.

Each ray has 12 entries.

PREPLOT How many columns to write out ? **2**

Row [1-12] : the individual column

Row [20] :  $R = \sqrt{X^2 + Y^2 + Z^2}$

Row [21] : angle from the Y-axis

Row [22] : the magnitude of A vector

Row [23] :  $A^2$

PREPLOT Row # 1 : **6**

PREPLOT 2 : **23**

Options - Enter

0 for excluding the losses

1 for including losses at a particular O.E.

2 for plotting all the rays .

3 for plotting ONLY the losses (all of them)

4 for plotting ONLY the losses at a given O.E.

PREPLOT Then ? **0**

## VMS

Output options :

[ 0 ] store rays in a file

[ 1 ] plot directly on screen

[ 2 ] both

Then ? **0**

PREPLOT Output file ? **STAR.02.PLT**

PREPLOT Terminal type: [0] VT240, [1] TEK 40xx, [2] HIREZ, [3] TEK 4107 : **1**

\*\*\*\*\*

Found 1000 good points out of 1000

## UNIX

Found 1000 good points out of 1000

Display type:

[ 0 ] Xwindow

[ 1 ] Tektronix

[ 2 ] Postscript file

Terminal type: **0**

% **mv preplot.dat star.02.dat**

We can now plot out the two cases, offset and not, together. This is a typical mode of using SHADOW, in order to appreciate the changes induced by small variations in the OS. Notice that we first read all the files and only at the end we PLOT. This is because TopDrawer determines the plot limits at the first occurrence of the PLOT command (unless they are user-specified). Since we are plotting the intensity versus the *angle*, the offset of the second crystal will cause the third plot to be out of bounds (try it). We created the following command file to plot the three images on the same graph.

Several interesting observations can be drawn from this plot. Notice the three curves. The highest one represents the intensity transmitted at each wavelength by the first crystal; notice that it is essentially identical with the rocking curve and is centered around zero. The second (lower) curve centered around zero represents the intensity transmitted by the *two* crystals; it is, in this case, equal to the square of the original intensity. The sides are thus more sharply defined, while the "bandpass" is not changed substantially. However, the fact that the sides are sharper means that the transmitted intensity is a better approximation to a rectangle, i.e., to an ideal monochromator. The third and smallest curve is clearly offset to the side. This is due to the rotation

imparted to the second crystal, so that the rays are not anymore coming out centered along the optical axis. This displaces the rocking curves of the two crystals relative to each other, thus giving the typical "spike". A careful observation will reveal the onset of the two different rocking curves. This is highlighted by the added traces.

## Two Crystals II

In this section of the primer we will reconsider the case of the two crystals, but with a different type of source. We will be using a *collimated* source with a continuous energy distribution. The crystals will be set at the same conditions as for the former case. There the change of angle across the face of the crystal produced the change in reflectivity and thus in intensity. In the present case it will be the change in *wavelength* that will give rise to a different reflectivity. Besides this, the run is exactly like the former one, so we will not repeat the full description.

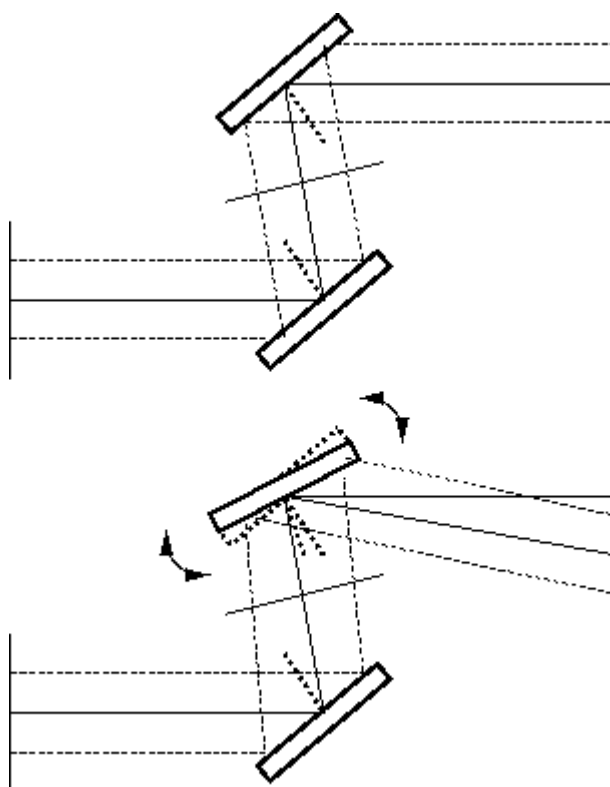

Fig. 1 - Two-crystal monochromator in parallel radiation

```
VMS
$ CREATE/DIRECTORY [.XTAL2]
$ SD [XRAYOP.XTAL2]
$ COPY [GAAS.PAR] [ ]*.*
UNIX
% mkdir ./xtal2
% cd ./xtal2
% cp ../gaas.par
GO SOURCE
```

SOURCE selected. Begin procedure.  
This procedure generates a SOURCE for SHADOW.

Mode selected [ ? <ret for HELP ] ? : **PROMPT**

Call to INPUT

```
----- S H A D O W ----- May 1993
F.Cerrina CXrL/ECE - UW
Defining source : When prompted for a yes/no answer, you may enter: for
YES answer Y, 1 for NO answer anything else
```

Do you want a verbose [ 1 ] or terse [ 0 ] output ? **0**

----- SOURCE SPECS -----

Source modelling type [ 0-5 ] ? **0**

How many rays [ 1 - 5 000 ] ? **1000**

Seed [ odd, 1000 - 1 000 000 ] ? **12345**

Do you want to optimize the source ? **0**

Source type : [ 0 ] regular source  
              [ 1 ] normal wiggler  
              [ 2 ] undulator  
              [ 3 ] elliptical wiggler

Then ? **0**

X-Z plane source type [ 0-3 ] ? **1**

Source Width [ x ] ? **1**

. Height [ z ] ? **1**

Source Depth [ 1-4 ] ? **1**

Source Angle Distribution [ 1-6 ] ? **1**

Horizontal half-divergence [ (+)x, rads ] ? **0**

. [ (-)x, rads ] ? **0**

Vertical [ (+)z, rads ] ? **0**

. [ (-)z, rads ] ? **0**

Do you want a Photon energy [ Y/N ] ? **1**

Energy distribution [ 1-3 ] ? **3**

Photon Energy [ 0 ] or Angstroms [ 1 ] ? **0**

From photon energy or wavelength ... ? **11156**

... to photon energy or wavelength : ? **11164**

Do you want to store the optical paths (OPD) [Y/N] ? **0**

Do you want to generate the A vectors (electric field) [Y/N] ? **0**

Exit from INPUT\_SOURCE

|           |                 |      |
|-----------|-----------------|------|
| Generated | 250 rays out of | 1000 |
|           | 500             |      |
|           | 750             |      |
|           | 1000            |      |

Exit from SOURCE

SOURCE = Source has been successfully generated.

SOURCE procedure completed.

Shadow:: **TRACE**

Ray Tracing Selected. Begin procedure.

Mode selected [ ? <ret for HELP ] ? : **PROMPT**

PROMPT selected.

Call to RESET

Exit from RESET

Mode selected is: PROMPT Options: to start anew [ 0 ] to restart from a given OE [ 1 ] Then ? **0**

Call to INPUT\_OE

----- S H A D O W -----

May 1993 F.Cerrina CXrL/ECE - UW

When prompted for a yes/no answer, you may enter:

for YES answer Y, 1

for NO answer anything else

Defining Optical Element: 1 Continue ? [ ^Z or %EXIT to terminate OS ] <ret

Do you want a verbose [ 1 ] or terse [ 0 ] output ? **0**

You may save disk space by not writing out the intermediate STAR or MIRR data files. In general you will not need them unless you have specific needs (footprints, etc.)

Files to write out. Options:

All..... [ 0 ]  
Mirror only..... [ 1 ]  
Image at CP only..... [ 2 ]  
None..... [ 3 ]

```

Then ? 0
  Optical Element definition:
Incidence Angle ? 10
Source Distance ? 5000
Reflection Angle? 10
Image Distance ? 149.8956
Reflector [ 0 ] or refractor [ 1 ] ? 0
A: Is this a Kumakhov system? 0
A: Is this mirror faceted [Y/N] ? 0
Mirror surface [ 1-9] ? 5
Is the mirror Cylindrical ? 0
Is this optical element a Fresnel Zone Plate ? 0
Are we dealing with a Grating ? 0
Are we dealing with a crystal [ Y/N ] ? 1
File containing crystal parameters ? GAAS.PAR
Is it a mosaic crystal [ Y/N ] ? 0
Is the crystal asymmetric [ Y/N ] ? 0
Are we working in Johansson geometry [Y/N] ? 0
Automatic Tuning of Crystal [ Y/N ] ? 1
Energy, in eV, [ 0 ] or wavelength, in Angs., [ 1 ] ? 0
Photon Energy ? 11160
Is the mirror convex [ Y/N ] ? 0
Reflectivity mode [ 0,1,2 ] ? 0
Orientation Angle [ Alpha ] ? 0
Mirror Dimensions finite [ Y/N ] ? 0
Do you want to move the Source [ Y/N ] ? 0
Do you want to move the mirror itself [ Y/N ] ? 0
Distorted surface [ Y/N ] ? 0
Do you want to include surface roughness [Y/N] ? 0
Any screens in this OE [ Y/N ] ? 0
Slit at continuation plane [ Y/N ] ? 0
Extra Image plates [ Y/N ] ? 0
File containing the source array ? BEGIN.DAT
  Exit from INPUT
  Tracing optical element #           1
  Call to SETSOUR
  .....
  Exit from RESET
Do you want to change input mode ? 0
  Call to INPUT_OE
----- S H A D O W -----
May 1993 F.Cerrina CXrL/ECE - UW
Defining Optical Element: 2 Continue ? [ ^Z or %EXIT to terminate OS ] <ret
Do you want a verbose [ 1 ] or terse [ 0 ] output ? 0
  You may save disk space by not writing out the intermediate STAR or MIRR
  data files. In general you will not need them unless you have specific
  needs (footprints, etc.)
Files to write out. Options:
All..... [ 0 ]
Mirror only.....[ 1 ] Image at CP only.....[ 2
]
None.....[ 3 ]
Then ? 0

  Optical Element definition:
Incidence Angle ? 10
Source Distance ? 149.8956
Reflection Angle? 10
Image Distance ? 5000
Reflector [ 0 ] or refractor [ 1 ] ? 0
A: Is this a Kumakhov system? 0
A: Is this mirror faceted [Y/N] ? 0
Mirror surface [ 1-9] ? 5

```

```

Is the mirror Cylindrical ? 0
Is this optical element a Fresnel Zone Plate ? 0
Are we dealing with a Grating ? 0
Are we dealing with a crystal [ Y/N ] ? 1
File containing crystal parameters ? GAAS.PAR
Is it a mosaic crystal [ Y/N ] ? 0
Is the crystal asymmetric [ Y/N ] ? 0
Are we working in Johansson geometry [Y/N] ? 0
Automatic Tuning of Crystal [ Y/N ] ? 1
Energy, in eV, [ 0 ] or wavelength, in Angs., [ 1 ] ? 0
Photon Energy ? 11160
Is the mirror convex [ Y/N ] ? 0
Reflectivity mode [ 0,1,2 ] ? 0
Orientation Angle [ Alpha ] ? 180
Mirror Dimensions finite [ Y/N ] ? 0
Do you want to move the Source [ Y/N ] ? 0
Do you want to move the mirror itself [ Y/N ] ? 0
Distorted surface [ Y/N ] ? 0
Do you want to include surface roughness [Y/N] ? 0
Any screens in this OE [ Y/N ] ? 0
Slit at continuation plane [ Y/N ] ? 0
Extra Image plates [ Y/N ] ? 0
Exit from INPUT
Tracing optical element #           2
Call to SETSOUR
.....
Exit from RESET
Do you want to change input mode ? 0
Call to INPUT_OE
----- S H A D O W -----
May 1993 F.Cerrina CXrL/ECE - UW
Defining Optical Element: 3
Continue ? [ ^Z or %EXIT to terminate OS ] ^Z

```

```

End of session
Procedure completed. Return to COMMAND level
Shadow: EXIT

```

```

Exit to DCL
$ TYPE EFFIC.01
Of a total of 1000 rays, of which 1000 formed the input set
0 were out of the mirror N. 1
The mirror collects 1.0000 of the incoming flux.
The average reflectivities are :
S-pol 0.36560
P-pol 0.34058
Total 0.35309
The overall efficiency of the mirror is : 0.35309
$ MIRINFO

```

```

----- M I R I N F O -----
vs. 3.0 - May 1993
MINFO Mirror descriptor file. It must be an END.xx type.
MINFO Please input filename: END.01
MINFO File read correctly.
MINFO Title ? PLANE CRYSTAL REFLECTION 2
MINFO Comment ? <ret
MINFO Output file ? MIRR.INF
MINFO Prepare output to file : MIRR.INF

```

**\$ TYPE MIRR.INF**

```
***** MIRROR DESCRIPTION *****
PLANE CRYSTAL REFLECTION 2
MIRR.INF
Input file specified:END.01
Full file Specification
:D13:[XRAYOP.XTAL2]END.01;1
Creation Date      :30-MAR-1987 14:04
Surface figure was defined as:      PLANE
Cylindrical figure                   NO
Element type                         REFLECTOR
Element type                         CRYSTAL
Lattice Spacing                      3.2620290209213856E-08
Bragg Reflection from
GAAS.PAR
Reflectivity                          OFF
Mirror dimensions                     UNLIMITED
Central Axis parameters :
Source Plane Distance                 5000.000000000000
Image Plane                          149.89560000000000
Incidence Angle                      80.19284670377978
Reflection/Diffraction Angle         80.19284670377978
Mirror parameters                    COMPUTED
Same configuration as Central Axis   NO
Objective focus at                   0.0000000000000000E+00
Image focus at                       0.0000000000000000E+00
Incidence angle                      0.0000000000000000E+00
Parameters used follow:
Plane mirror
Source of this O.E. moved            NO
Mirror at pole position ( no mov. )  YES
```

**VMS**

**\$ DIR**

```
Directory D13:[XRAYOP.XTAL2]
BEGIN.DAT;1      188 30-MAR-1987 14:01      (RWED,RWED,RE,RE)
EFFIC.01;1      1 30-MAR-1987 14:03      (RWED,RWED,RE,RE)
EFFIC.02;1      1 30-MAR-1987 14:05      (RWED,RWED,RE,RE)
END.00;1        6 30-MAR-1987 14:01      (RWED,RWED,RE,RE)
END.01;1       11 30-MAR-1987 14:04      (RWED,RWED,RE,RE)
END.02;1       11 30-MAR-1987 14:05      (RWED,RWED,RE,RE)
GAAS.PAR;1      4 26-MAR-1987 14:17      (RWED,RWED,RE,RE)
MIRR.01;1      188 30-MAR-1987 14:03      (RWED,RWED,RE,RE)
MIRR.02;1      188 30-MAR-1987 14:05      (RWED,RWED,RE,RE)
MIRR.INF;1      5 30-MAR-1987 14:07      (RWED,RWED,RE,RE)
OPTAX.01;1      2 30-MAR-1987 14:03      (RWED,RWED,RE,RE)
OPTAX.02;1      3 30-MAR-1987 14:05      (RWED,RWED,RE,RE)
STAR.01;1      188 30-MAR-1987 14:03      (RWED,RWED,RE,RE)
STAR.02;1      188 30-MAR-1987 14:05      (RWED,RWED,RE,RE)
START.00;1      6 30-MAR-1987 14:01      (RWED,RWED,RE,RE)
START.01;1     11 30-MAR-1987 14:03      (RWED,RWED,RE,RE)
START.02;1     11 30-MAR-1987 14:05      (RWED,RWED,RE,RE)
Total of 17 files, 1012 blocks.
```

**UNIX**

**% ls -al**

```
total 1192
drwxrwsr-x  2 shadow      512 Jun 11 11:22 .
drwxr-sr-x  4 shadow      1024 Jun 11 11:09 ..
-rw-rw-r--  1 shadow     104020 Jun 11 11:12 begin.dat
-rw-rw-r--  1 shadow      371 Jun 11 11:12 effic.01
-rw-rw-r--  1 shadow      371 Jun 11 11:12 effic.02
-rw-rw-r--  1 shadow     1506 Jun 11 11:12 end.00
```

```

-rw-rw-r-- 1 shadow      4540 Jun 11 11:12 end.01
-rw-rw-r-- 1 shadow      4555 Jun 11 11:12 end.02
-rw-r--r-- 1 shadow      1485 Jun 11 11:09 gaas.par
-rw-rw-r-- 1 shadow     104020 Jun 11 11:12 mirr.01
-rw-rw-r-- 1 shadow     104020 Jun 11 11:12 mirr.02
-rw-rw-r-- 1 shadow       2262 Jun 11 11:22 mirr.inf
-rw-rw-r-- 1 shadow       297 Jun 11 11:12 optax.01
-rw-rw-r-- 1 shadow       742 Jun 11 11:12 optax.02
-rw-rw-r-- 1 shadow     104020 Jun 11 11:12 star.01
-rw-rw-r-- 1 shadow     104020 Jun 11 11:12 star.02
-rw-rw-r-- 1 shadow      1500 Jun 11 11:11 start.00
-rw-rw-r-- 1 shadow      4451 Jun 11 11:12 start.01
-rw-rw-r-- 1 shadow      4466 Jun 11 11:12 start.02
-rw-rw-r-- 1 shadow        30 Jun 11 11:12 systemfile.dat

```

**\$ PREPLOT**

PREPLOT Input file ? **STAR.02**

```

Read                1000 rays.
Each ray has        12 entries.
PREPLOT How many columns to write out ? 2

```

```

Row [1-12] : the individual column
Row  [20]  : R = SQRT(X**2 + Y**2 + Z**2)
Row  [21]  : angle from the Y-axis
Row  [22]  : the magnitude of A vector
Row  [23]  : A**2

```

PREPLOT Row # 1 : **11**

PREPLOT 2 : **23**

```

// Note, here we are plotting energy vs. amplitude squared.
Option: Angstroms      [ 0 ]
        Electronvolts  [ 1 ]
        Cm-1           [ 2 ]

```

PREPLOT Then ? **1**

```

Options - Enter
0      for excluding the losses
1      for including losses at a particular O.E.
2      for plotting all the rays .
3      for plotting ONLY the losses (all of them)
4      for plotting ONLY the losses at a given O.E.

```

PREPLOT Then ? **0**

**VMS**

```

Output options :
[ 0 ] store rays in a file
[ 1 ] plot directly on screen
[ 2 ] both

```

Then ? **0**

PREPLOT Output file ? **STAR02.PLT**

PREPLOT Terminal type: [0] VT240, [1] TEK 40xx, [2] HIREZ, [3] TEK 4107 : **2**

\*\*\*\*\*

```

Found          1000 good points out of          1000

```

**UNIX**

Found 1000 good points out of 1000

Display type:

```

[ 0 ] Xwindow
[ 1 ] Tektronix
[ 2 ] Postscript file

```

Terminal type: **0**

**% MV PREPLOT.DAT STAR.02.DAT**

Now the second crystal will be offset.

**VMS**

**\$**

**\$ CREATE/DIRECTORY [.OFFSET2]**

**\$ SET DEF [.OFFSET2]**

```

$ COPY [-]STAR.01,GAAS.PAR [ ]
$ COPY [-]OPTAX.01 [ ]
UNIX
%
% mkdir offset2
% cd offset2
% cp ../star.01
% cp ../gaas.par
% cp ../optax.01

```

**\$ GO TRACE**

```

Ray Tracing Selected. Begin procedure.
Mode selected [ ? <ret for HELP ] ? : PROMPT
  PROMPT selected.
  Call to RESET
  Exit from RESET
Mode selected is: PROMPT Options: to start anew [ 0 ] to restart from a
given OE [ 1 ] Then ? 1
Previous element number : 1
Image file of the previous OE ? STAR.01
Do you want to change the input mode ? 0
  Call to INPUT_OE
----- S H A D O W ----- May 1993
F.Cerrina CXrL/ECE - UW
Defining Optical Element: 2 Continue ? [ ^Z or %EXIT to terminate OS ] <ret
Do you want a verbose [ 1 ] or terse [ 0 ] output ? 0
  You may save disk space by not writing out the intermediate STAR or MIRR
  data files. In general you will not need them unless you have specific
  needs (footprints, etc.)
Files to write out. Options:
All..... [ 0 ]
Mirror only.....[ 1 ]
Image at CP only.....[ 2 ]
None.....[ 3 ]
Then ? 0
  Optical Element definition:
Incidence Angle ? 10
Source Distance ? 149.8956
Reflection Angle? 10
Image Distance ? 5000
Reflector [ 0 ] or refractor [ 1 ] ? 0
A: Is this a Kumakhov system? 0
A: Is this mirror faceted [Y/N] ? 0
Mirror surface [ 1-9 ] ? 5
Is the mirror Cylindrical ? 0
Is this optical element a Fresnel Zone Plate ? 0
Are we dealing with a Grating ? 0
Are we dealing with a crystal [ Y/N ] ? 1
File containing crystal parameters ? GAAS.PAR
Is it a mosaic crystal [ Y/N ] ? 0
Is the crystal asymmetric [ Y/N ] ? 0
Are we working in Johansson geometry [Y/N] ? 0
Automatic Tuning of Crystal [ Y/N ] ? 1
Energy, in eV, [ 0 ] or wavelength, in Angs., [ 1 ] ? 0
Photon Energy ? 11160
Is the mirror convex [ Y/N ] ? 0
Reflectivity mode [ 0,1,2 ] ? 0
Orientation Angle [ Alpha ] ? 180
Mirror Dimensions finite [ Y/N ] ? 0
Do you want to move the Source [ Y/N ] ? 0
Do you want to move the mirror itself [ Y/N ] ? 1
Rotation around X axis [ degrees ] ? 2.777E-3

```



```

.Y. ? <ret
.Z. ? <ret
Mirror Offset. In X ? <ret
.Y ? <ret
.Z ? <ret
Distorted surface [ Y/N ] ? 0
Do you want to include surface roughness [Y/N] ? 0
Any screens in this OE [ Y/N ] ? 0
Slit at continuation plane [ Y/N ] ? 0
Extra Image plates [ Y/N ] ? 0
Exit from INPUT
  Tracing optical element #           2
  Call to SETSOUR
  .....
  Exit from RESET
Do you want to change input mode ? 0
  Call to INPUT_OE
----- S H A D O W ----- May 1993
F.Cerrina CXrL/ECE - UW
Defining Optical Element: 3
Continue ? [ ^Z or %EXIT to terminate OS ] ^Z
  End of session
  Procedure completed. Return to COMMAND level
Shadow:: EXIT

  Exit to DCL
$ PREPLOT

PREPLOT Input file ? STAR.01
  Read           1000 rays.
  Each ray has   12 entries.
PREPLOT How many columns to write out ? 2
  Row [1-12] : the individual column
  Row  [20] : R = SQRT(X**2 + Y**2 + Z**2)
  Row  [21] : angle from the Y-axis
  Row  [22] : the magnitude of A vector
  Row  [23] : A**2
PREPLOT Row # 1 : 11
PREPLOT 2 : 23
  Option:   Angstroms      [ 0 ]
           Electronvolts  [ 1 ]
           Cm-1            [ 2 ]
PREPLOT Then ? 1
  Options - Enter
  0   for excluding the losses
  1   for including losses at a particular O.E.
  2   for plotting all the rays .
  3   for plotting ONLY the losses (all of them)
  4   for plotting ONLY the losses at a given O.E.
PREPLOT Then ? 0

VMS
  Output options :
  [ 0 ] store rays in a file
  [ 1 ] plot directly on screen
  [ 2 ] both
Then ? 0
PREPLOT Output file ? STAR01.PLT
*****
  Found           1000 good points out of           1000
UNIX
  Found 1000 good points out of 1000
  Display type:
  [ 0 ] Xwindow
  [ 1 ] Tektronix

```

```

[ 2 ] Postscript file
Terminal type: 0
% mv preplot.dat star.01.dat
$
$ PREPLOT

PREPLOT Input file ? STAR.02
Read          1000 rays.
Each ray has  12 entries.
PREPLOT How many columns to write out ? 2
Row [1-12]   : the individual column
Row  [20]    : R = SQRT(X**2 + Y**2 + Z**2)
Row  [21]    : angle from the Y-axis
Row  [22]    : the magnitude of A vector
Row  [23]    : A**2
PREPLOT Row # 1 : 11
PREPLOT 2 : 23
Option:      Angstroms      [ 0 ]
            Electronvolts   [ 1 ]
            Cm-1             [ 2 ]
PREPLOT Then ? 1
Options - Enter
0          for excluding the losses
1          for including losses at a particular O.E.
2          for plotting all the rays .
3          for plotting ONLY the losses (all of them)
4          for plotting ONLY the losses at a given O.E.
PREPLOT Then ? 0

VMS
Output options :
  [ 0 ] store rays in a file
  [ 1 ] plot directly on screen
  [ 2 ] both
Then ? 0
PREPLOT Output file ? STAR.02.PLT
*****
Found          1000 good points out of          1000

UNIX
Found 1000 good points out of 1000
Display type:
[ 0 ] Xwindow
[ 1 ] Tektronix
[ 2 ] Postscript file
Terminal type: 0
% mv preplot.dat star.02.dat

```