



the
abdus salam
international centre for theoretical physics

40th anniversary
1964
2004

H4.SMR/1586-9

**"7th Workshop on Three-Dimensional Modelling
of Seismic Waves Generation and their Propagation"**

25 October - 5 November 2004

**Trends and Advances in Surface
Wave Tomography and Inversion**

*M. Ritzwoller
Center for Imaging the Earth's Interior
Boulder, CO
U.S.A.*

Trends and Advances in Surface Wave Tomography and Inversion

Mike Ritzwoller

Center for Imaging the Earth's Interior

Department of Physics

University of Colorado at Boulder

Boulder, CO 80309-0390

Pubs: ciei.colorado.edu/ritzwoller

ritzwoller@ciei.colorado.edu

1 1(303) 492 7075

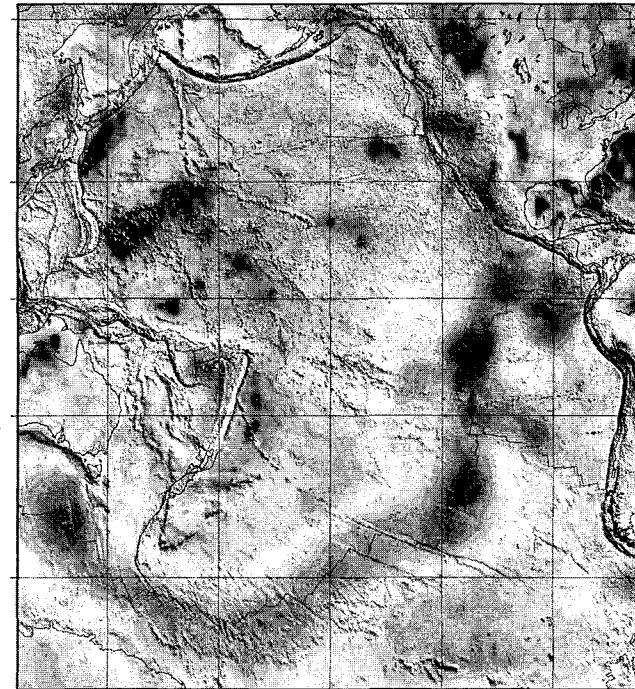

Collaborators:

Anatoli Levshin

Nikolai Shapiro

M. Campillo

C. Jaupart

J.-C. Mareschal

S. Zhong

Outline

- 1. A (very) little background on surface waves and inverse problems.**
- 2. Surface wave tomography.**
- 3. Monte Carlo surface wave inversion.**
- 4. Application of physical constraints in the inversion:**
 - a. Data assimilation; e.g., surface heat flux.**
 - b. Underlying physical model.**
- 5. New measurement method: use of the random wave-field.**

1. Background

- What surface waves look like: Rayleigh/Love, dispersion, phase and group speed.
- Distribution of earthquakes and receivers:
 - GSN, GEOSCOPE, GEOFON, PASSCAL, EarthScope, many others.
- Observation of dispersion.
- Depth sensitivity. (Lateral sensitivity later.)
- Comments on inverse problems.

Seismic data

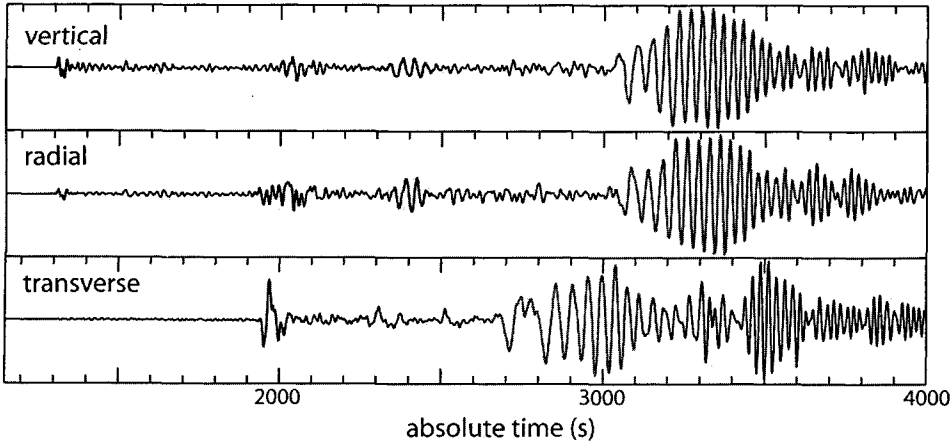
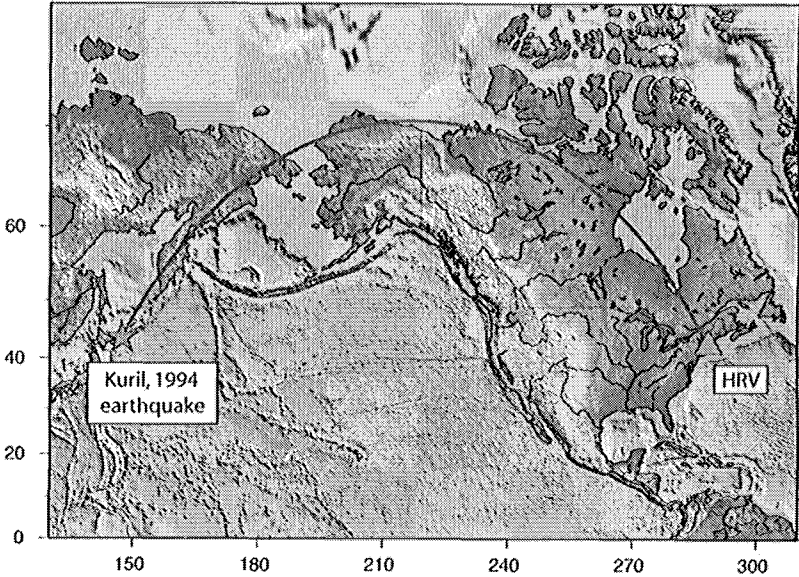
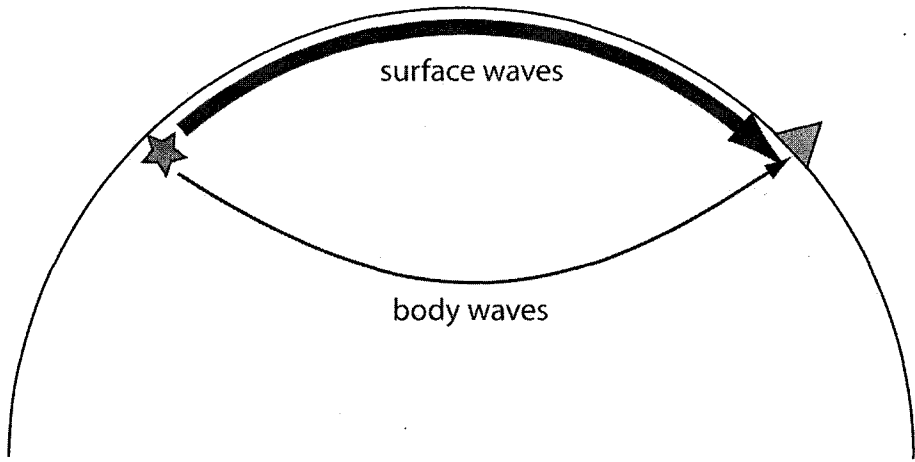

Body waves sample deep parts of the Earth

Surface waves sample the crust and upper mantle

Seismic surface-waves

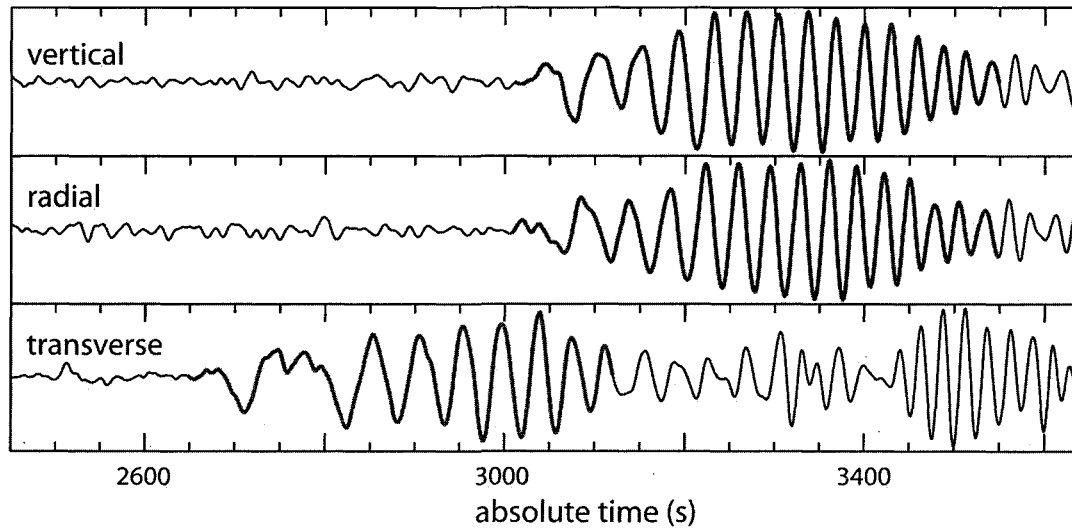

1. Two types: **Rayleigh** and **Love**
2. **Dispersion**: travel times depend on period of wave
3. Two types of travel time measurements: **phase** and **group**

Dataset



- More than 200,000 paths across the globe
- Rayleigh and Love wave phase velocities (40-150 s)
(Harvard, Utrecht)
- Rayleigh and Love wave group velocities (16-200 s)
(CU-Boulder)

Japan to Finland

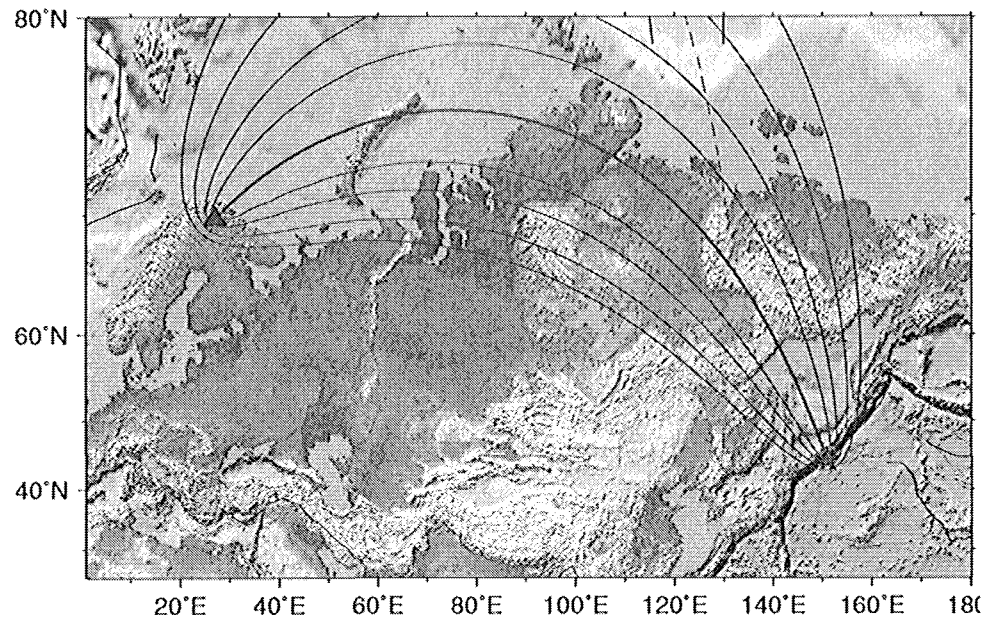

Sensitivity kernels
are spatially extended
and period-dependent.

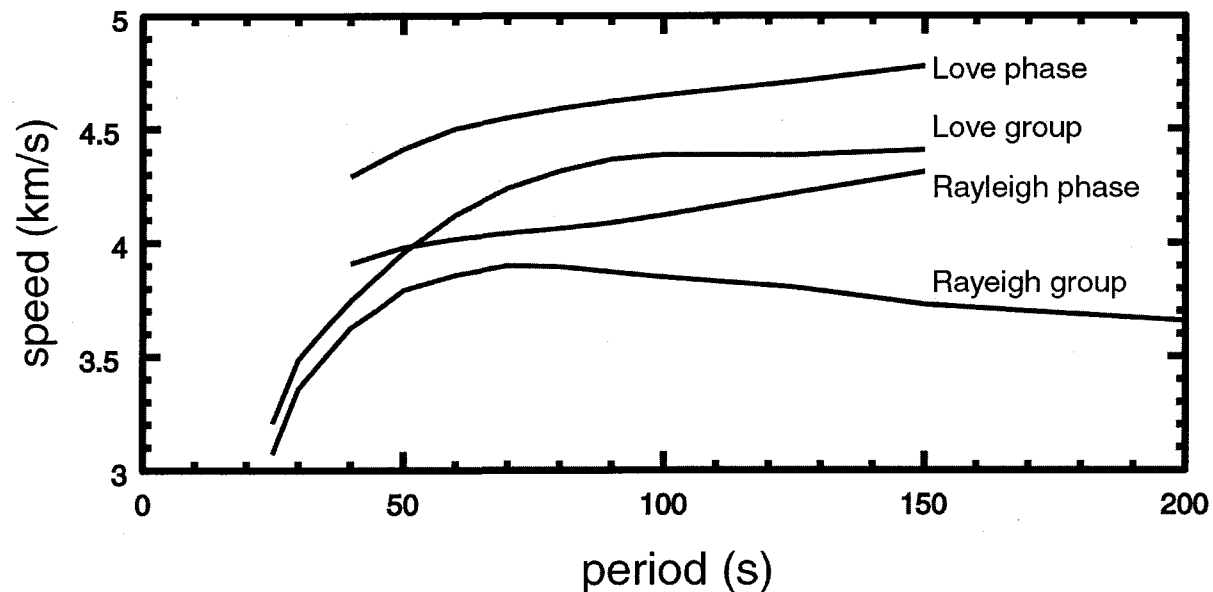

Surface waves are
observed to be
dispersed: wave speeds
depend on period and
also wave type.

Depth Sensitivity of Surface Waves

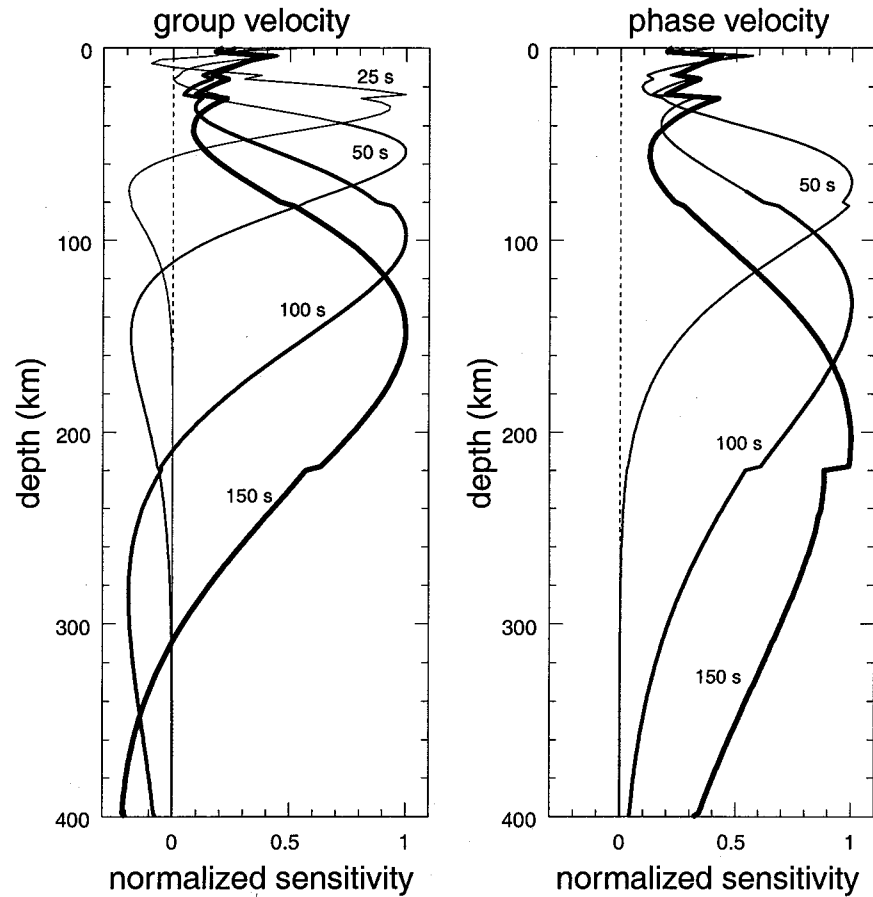

Vs kernels for Rayleigh waves

Longer periods are sensitive to deeper structures: vertical resolution.

Group speed vertical sensitivity kernels are more complicated than phase speed kernels & and effectively sample more shallowly at each period.

Rayleigh waves are sensitive to deeper structures than Love waves at the same period.

Sensitivity predominantly to V_s , but also some sensitivity to V_p in the crust and to density.

What's an inverse problem?

Reasoning backwards: from data to model.

Most people, if you describe a train of events to them, will tell you what the result would be. There are few people, however, who, if you told them a result, would be able to evolve from their own inner consciousness what the steps were which led up to that result. This power is what I mean by reasoning backwards.

Sherlock Holmes,
A Study in Scarlet, by Sir A.C. Doyle

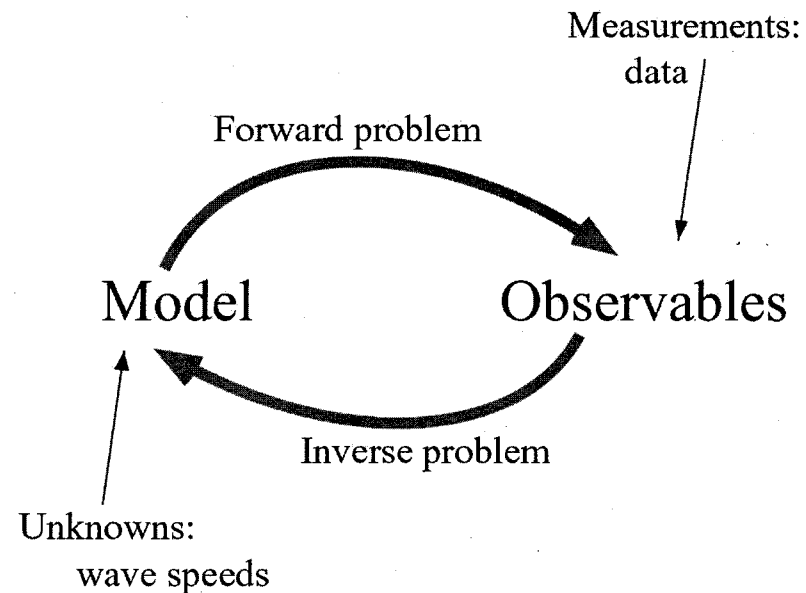

Forward Problem and Misfit

Data/model relationship (linear, weakly nonlinear, nonlinear)

$$\mathbf{d} = g(\mathbf{m})$$

(accuracy of this relation will
affect the outcome of the inversion)

To fit data, we need a measure of misfit

$$\phi(\mathbf{d}, \mathbf{m}) = (\mathbf{d} - g(\mathbf{m}))^T C_D^{-1} (\mathbf{d} - g(\mathbf{m}))$$

(weighted L2-norm)

For a linearized problem

$$\phi(\delta\mathbf{d}, \delta\mathbf{m}) = (\delta\mathbf{d} - G\delta\mathbf{m})^T C_D^{-1} (\delta\mathbf{d} - G\delta\mathbf{m})$$

Linear problems and non-uniqueness

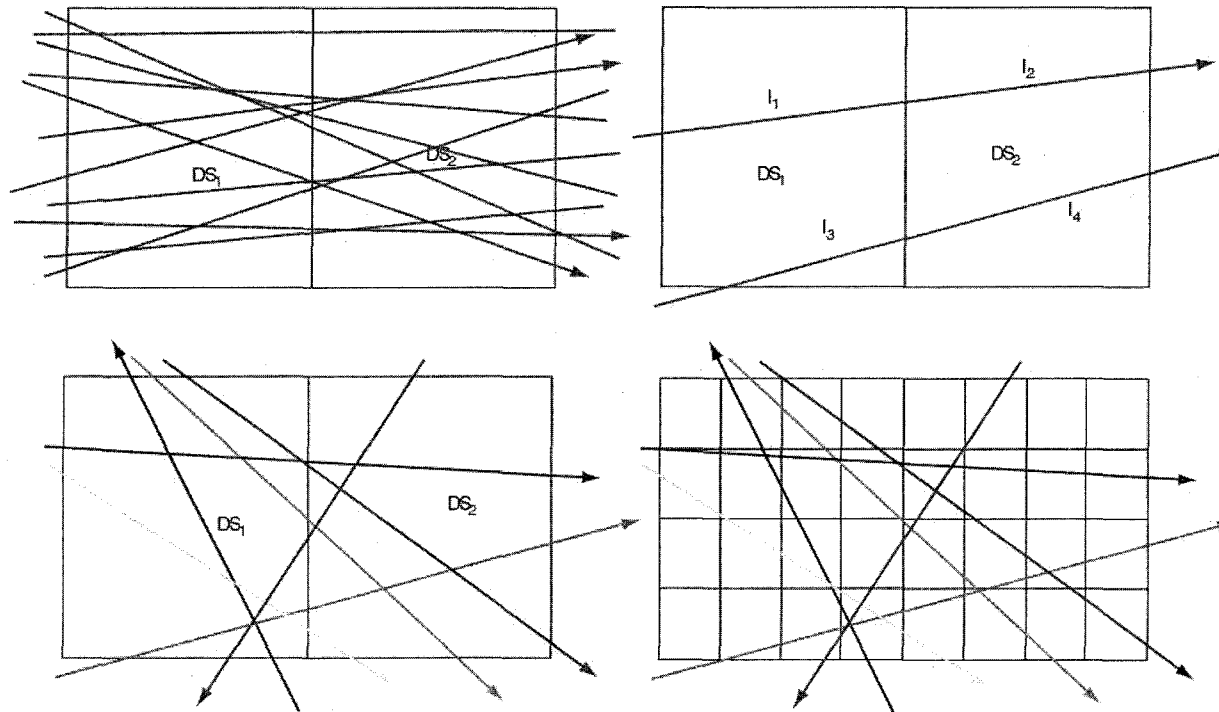
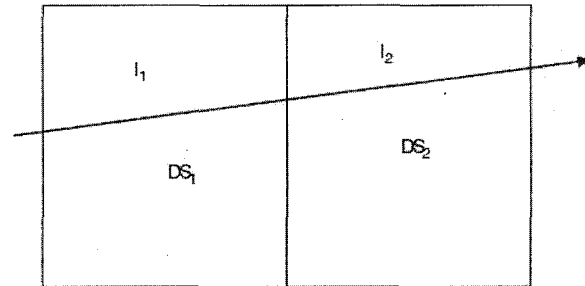

(courtesy of Malcolm Sambridge)

Regularization and Optimization

To prevent extravagant behavior of the model we need to introduce some form of explicit regularization. For example,

$$\psi(\mathbf{m}) = (\mathbf{m} - \mathbf{m}_0)^T C_M^{-1} (\mathbf{m} - \mathbf{m}_0)$$

(weighted model norm)

A common thing to do is to minimize a combination of data misfit and model norm.

$$\chi(\mathbf{m}) = \phi(\mathbf{d}, \mathbf{m}) + \lambda^2 \chi(\mathbf{m})$$

λ is a trade-off parameter.

(courtesy of Malcolm Sambridge)

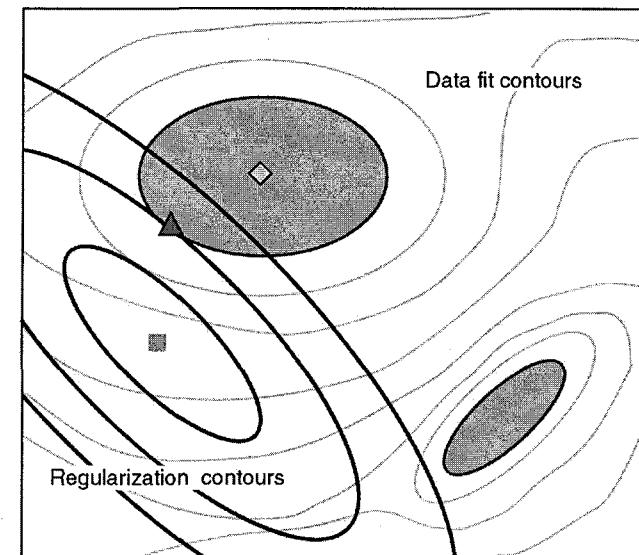

- - Data acceptable solutions
- ◇ - *Optimal data fit solution (c.f. MAP)*
- ▲ - *Extremal solution*

Approaches to Constructing the Model

For a linearized problem:

$$\mathbf{m}(\lambda) = (\mathbf{G}^T \mathbf{C}_D^{-1} \mathbf{G} + \lambda \mathbf{Q})^{-1} \mathbf{G}^T \mathbf{C}_D^{-1} \mathbf{d}$$

\mathbf{G} - Linearized forward operator

\mathbf{Q} - Regularization constraint

For a non-linear problem:

Model space search methods -- e.g., simulated annealing, genetic algorithms, evolutionary programs, neighborhood sampling, etc.

We use a simple **Monte-Carlo** method to attempt to identify the range of models within model space that fit the data adequately and are physically reasonable.

Uniform Monte Carlo Inversion in Geophysics

A whole earth Monte Carlo inversion by Press (1968)

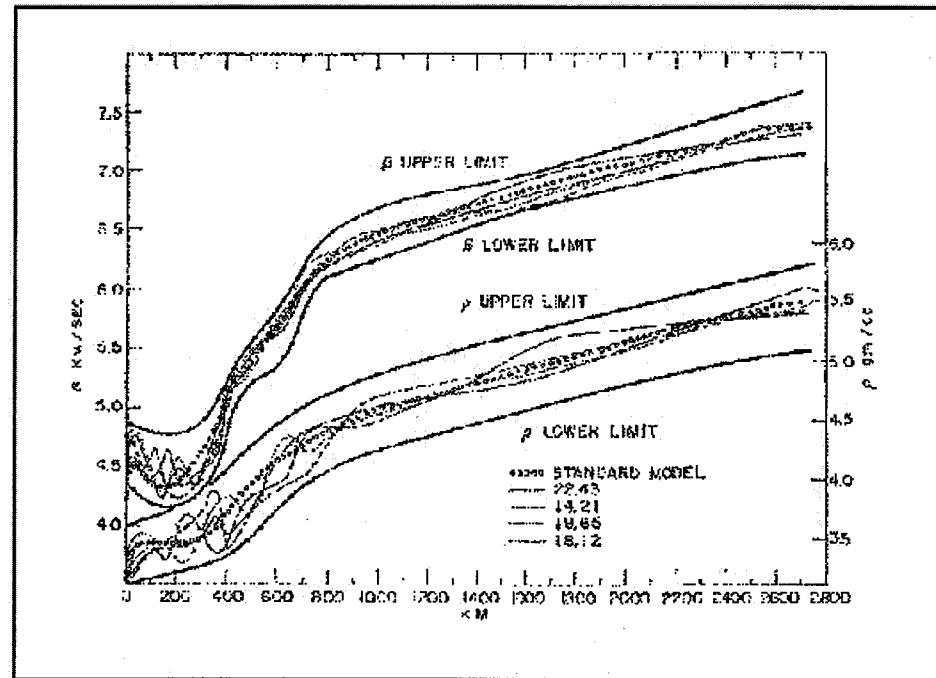
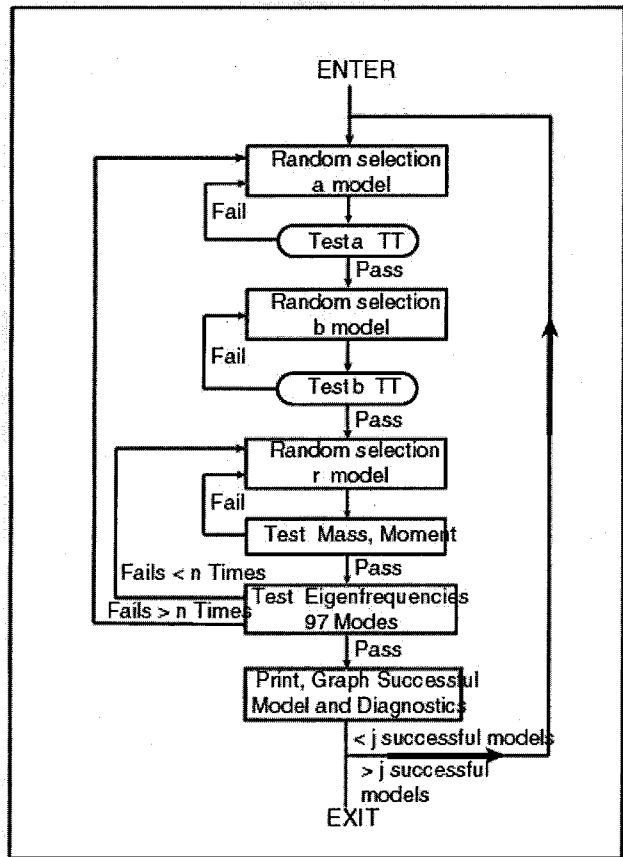

Keilis-Borok & Yanovskaya (1967) first introduced Monte-Carlo inversion into geophysics.

Outline of Surface Wave Inversion

Seismic Method

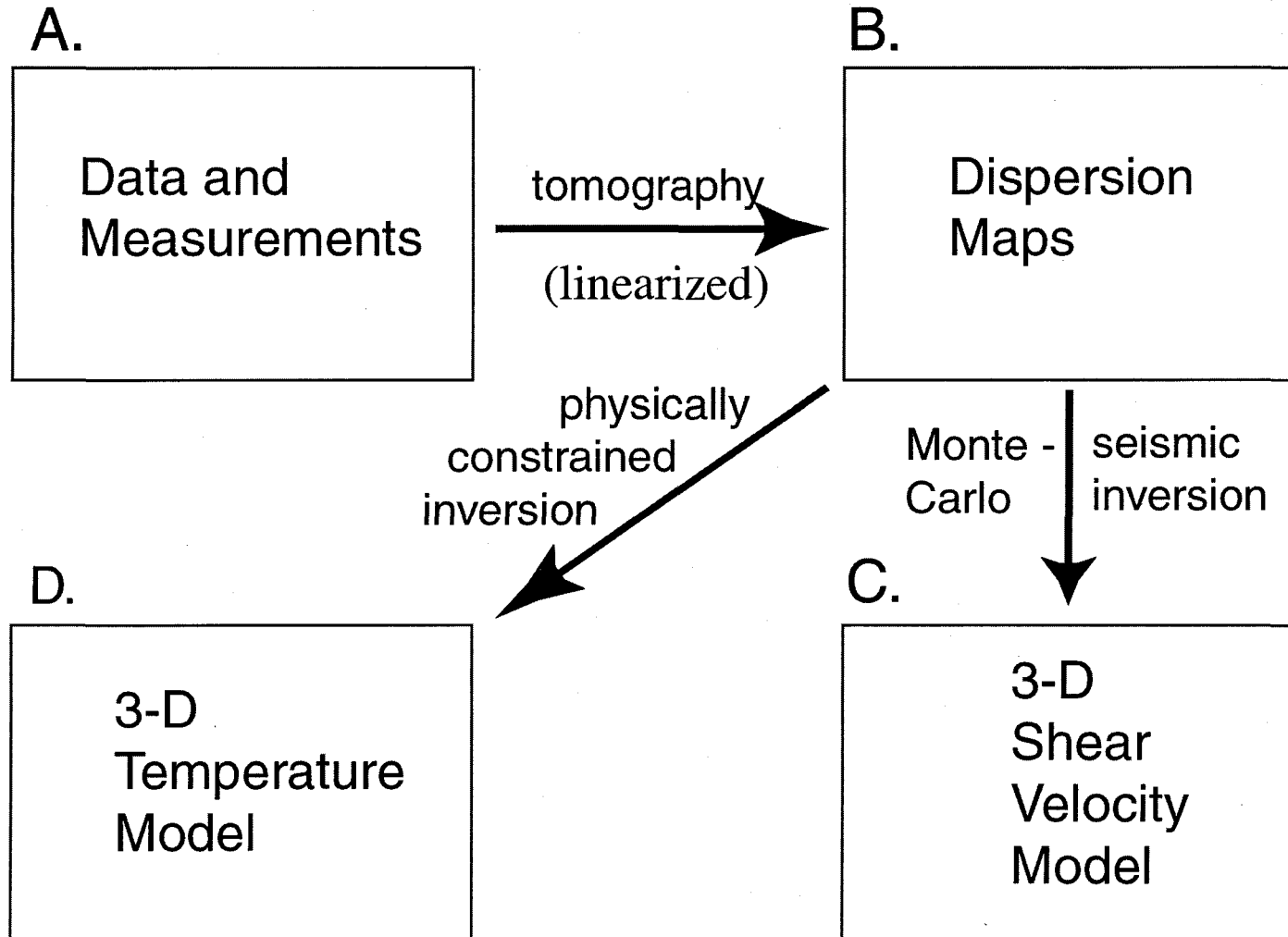

Surface Wave Inversion Without Physical Constraints

Two Stage Inversion Process:

2. Dispersion Maps:

Measurements of dispersion are inverted for maps of local wave speed at different periods and wave types.

3. 3-D Vs Model:

The dispersion maps are inverted on a global grid to estimate the 3-D distribution of shear wave speed in the earth's crust and uppermost mantle.

Seismic Inversion

(Pejorative) Comments on the State-of-the Art:

- + Systematic Errors: e.g., the theory of wave propagation is not fully accurate and is continuing to evolve.
- + Application of a priori information is almost completely subjective, ad-hoc, and usually is not reported.
- + Practitioners typically produce only a single model and report no information about confidence.
- + The 3-D distribution of seismic wave speeds is not what we're really interested in.

2. Surface Wave Tomography

- Diffraction.
- Sensitivity kernels.
- Some results of diffraction tomography.

Diffraction -- Effect of a Spherical Anomaly

Note: wave-front healing

Figure 2.5-19: Waves interacting with a spherical anomaly. (from Stein & Wysession, 2002)

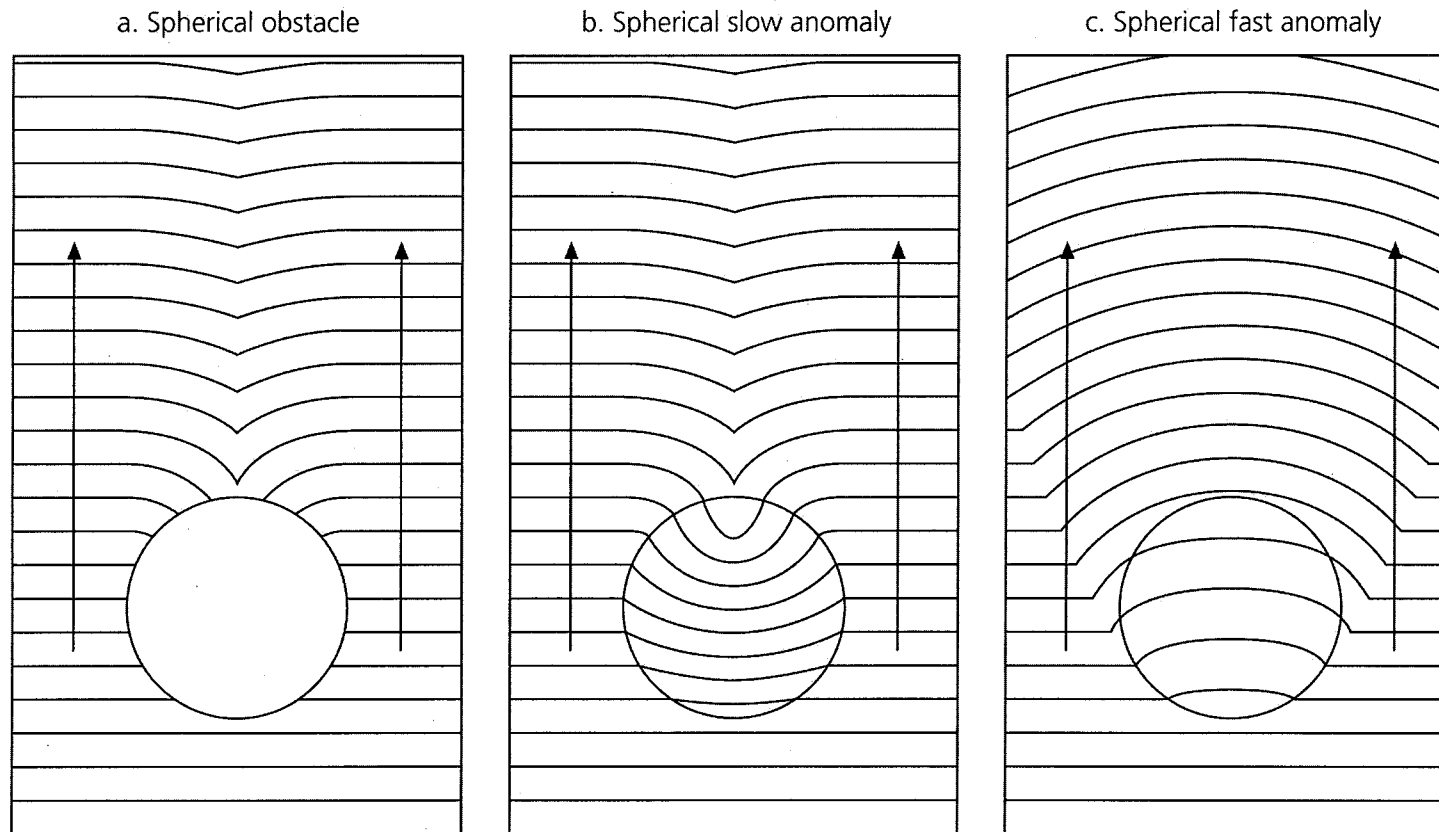

Effect of a Scatterer on an Observed Signal: Surface Wave Diffraction

Acoustic Simulation

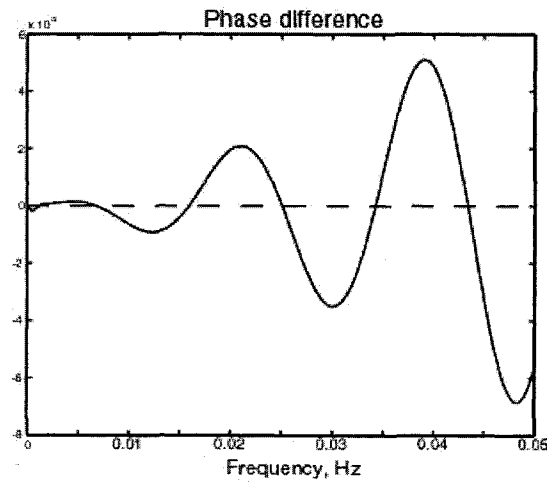
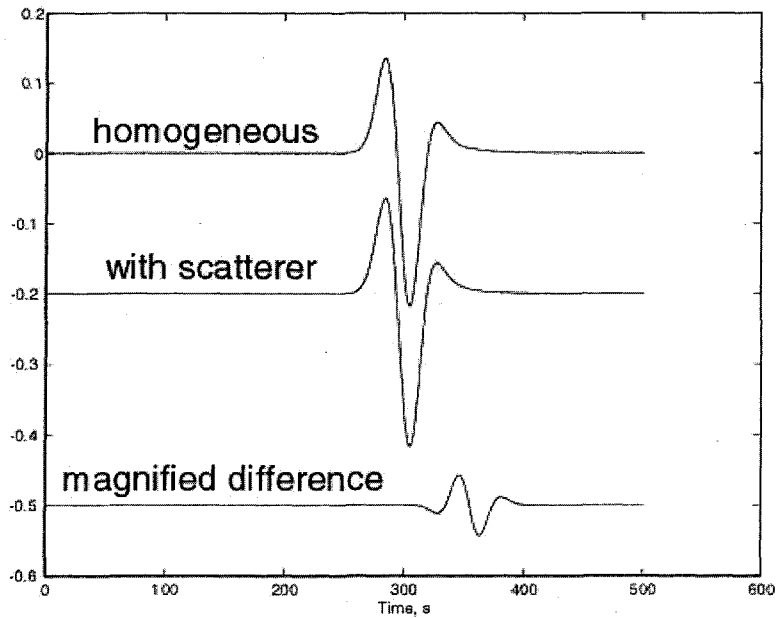
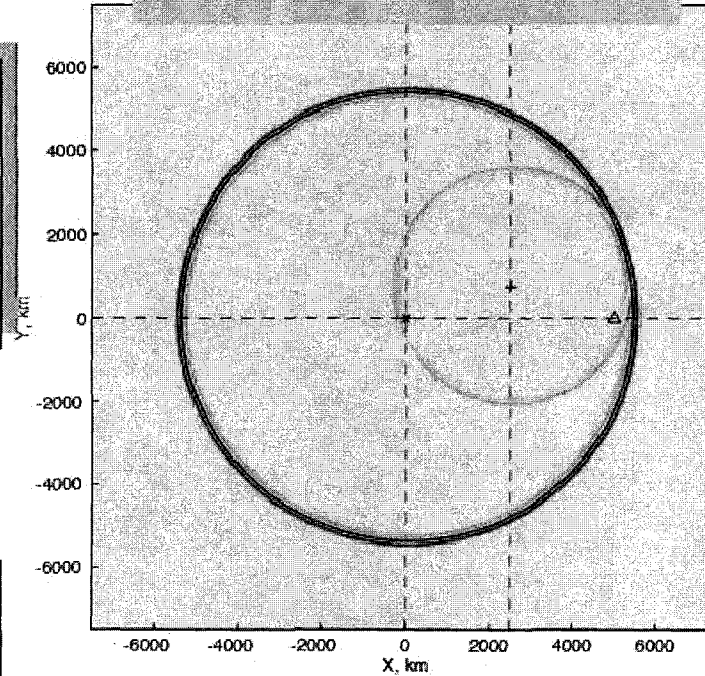

Putting it All Together into A Sensitivity Kernel

$$\delta t_{S,R} = \int K_{S,R}(\mathbf{r}) \delta m(\mathbf{r}) dA$$

Full kernel

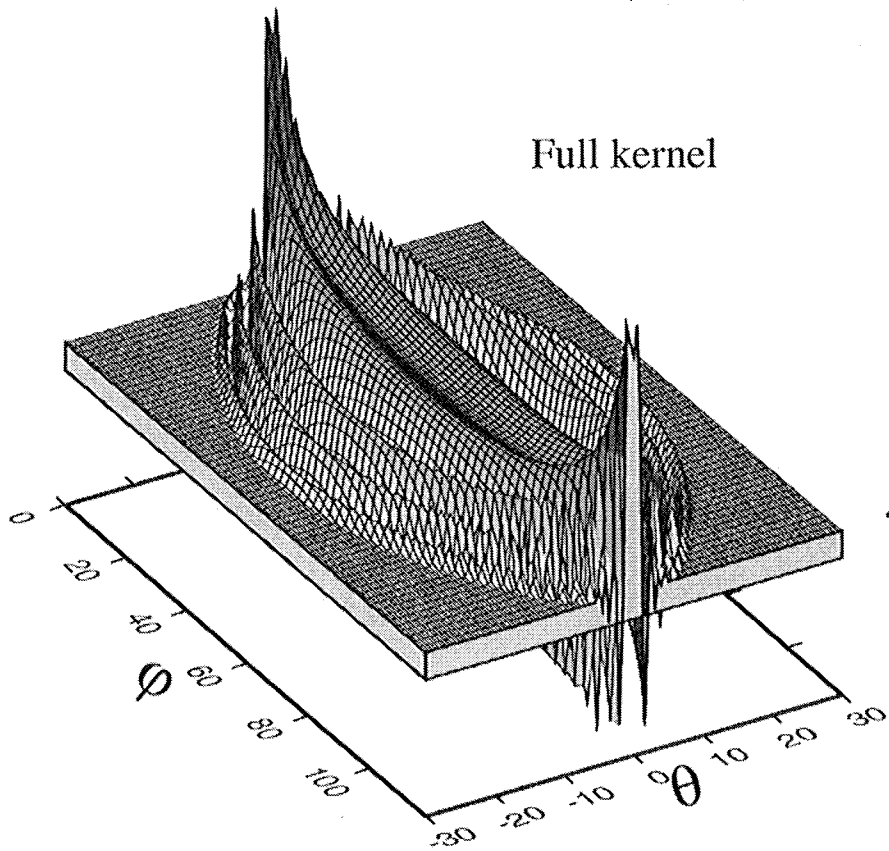

First Fresnel zone approximation

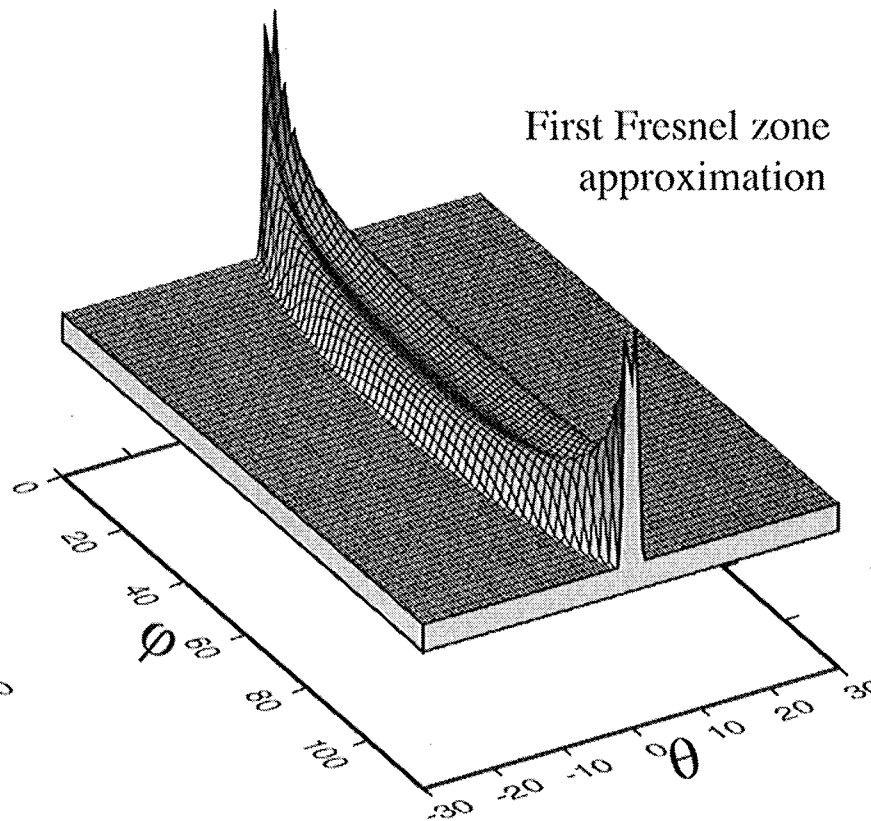

Forward Problem: Spatially extended sensitivity kernels model diffraction and wave-front healing.

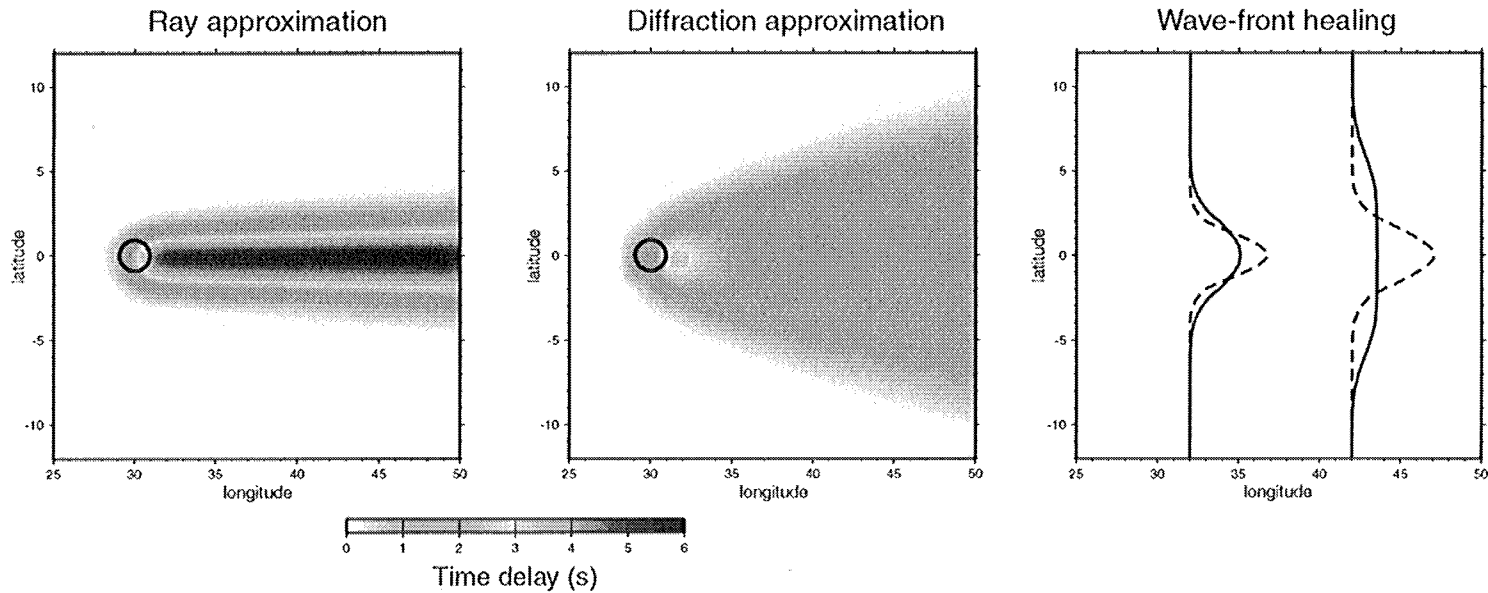
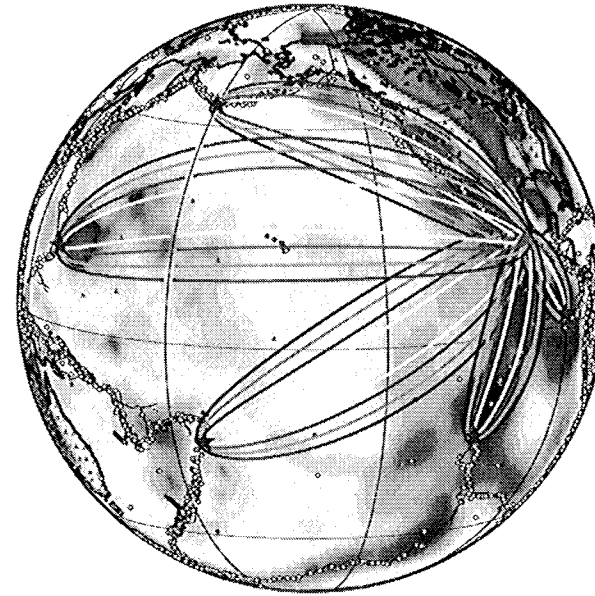

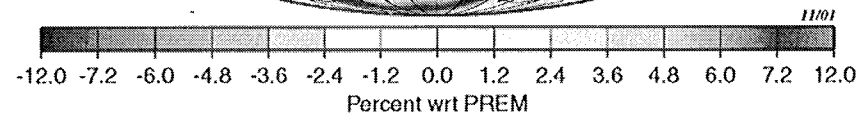
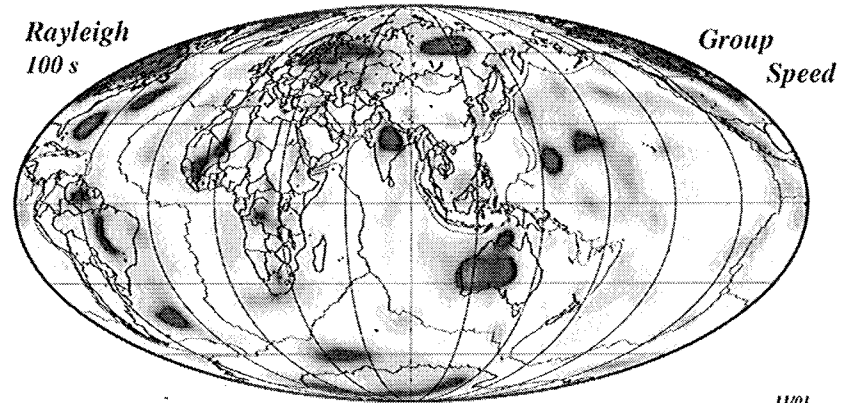
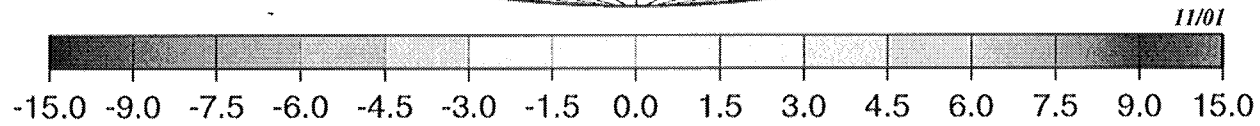
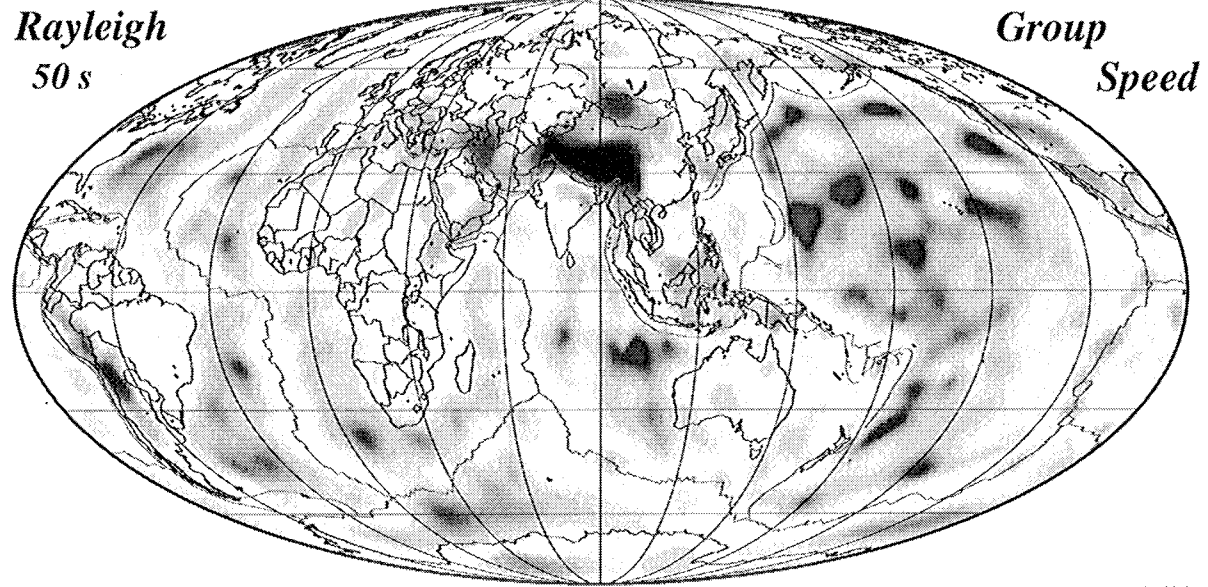

Example of a
Dispersion Map

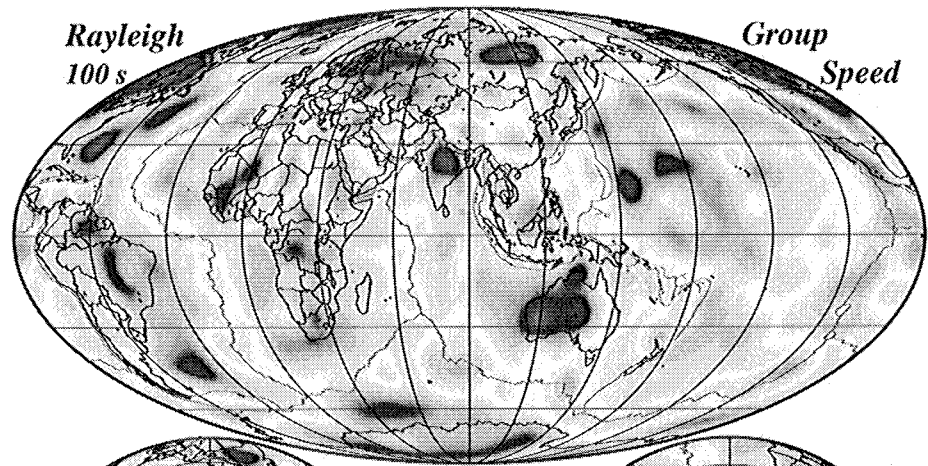

Blue: fast.
e.g., cratons,
old oceans

Red: slow.
e.g., deforming regions,
young oceans.

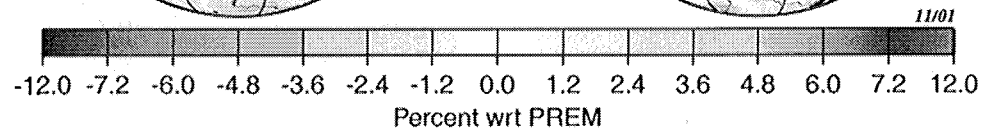
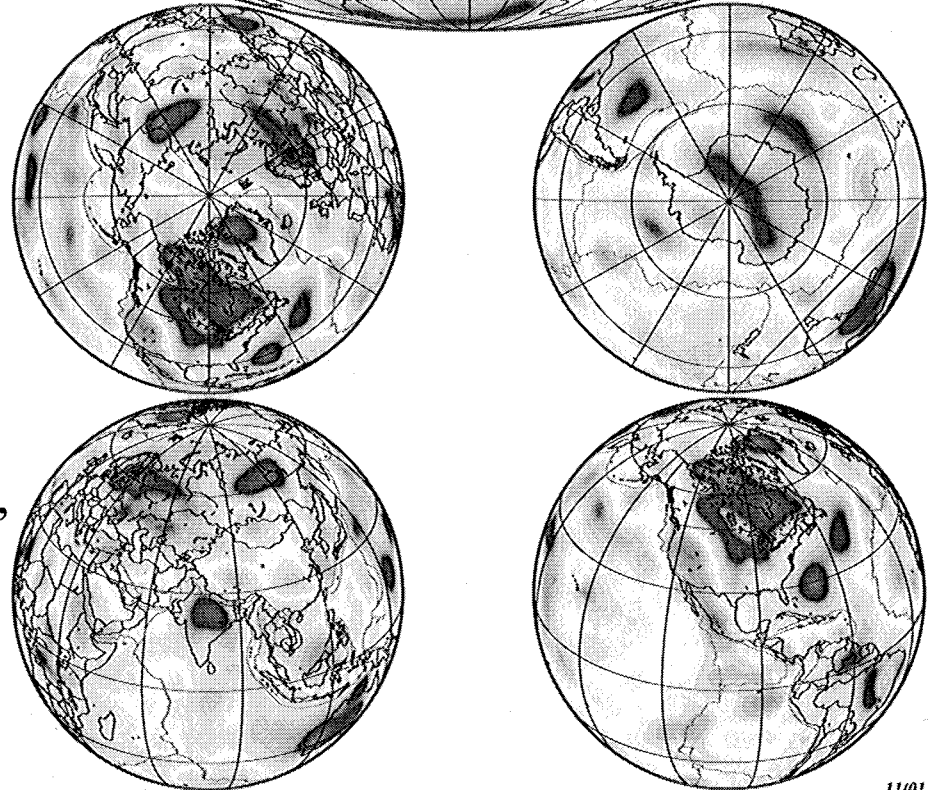

3. Monte Carlo Inversion

- Shear speed distribution in the Earth.
- Range of models that fit the data & our a priori expectations.
- Parameterization (seismic).
- Some results, including the effect of the use of diffraction kernels.

C. Inversion of dispersion curves

All dispersion maps: Rayleigh and Love wave group and phase velocities at all periods

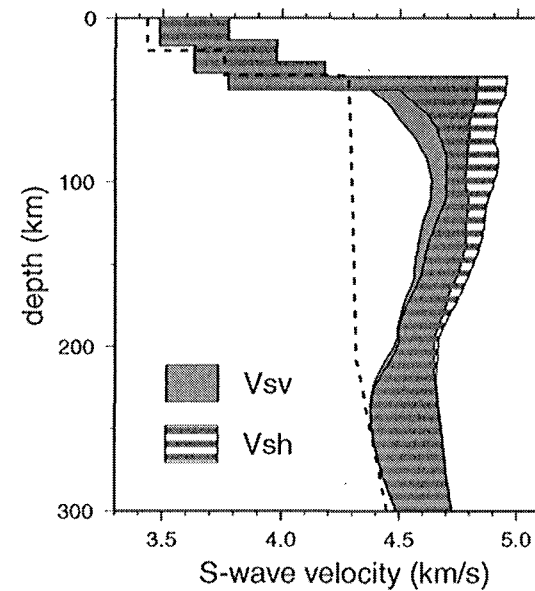
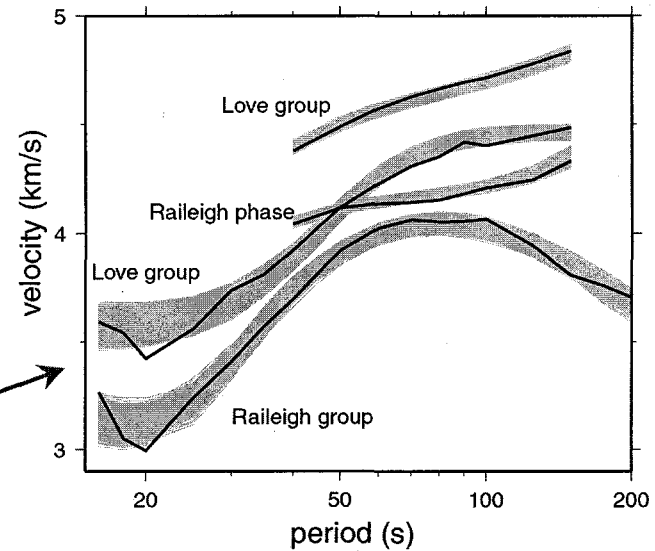
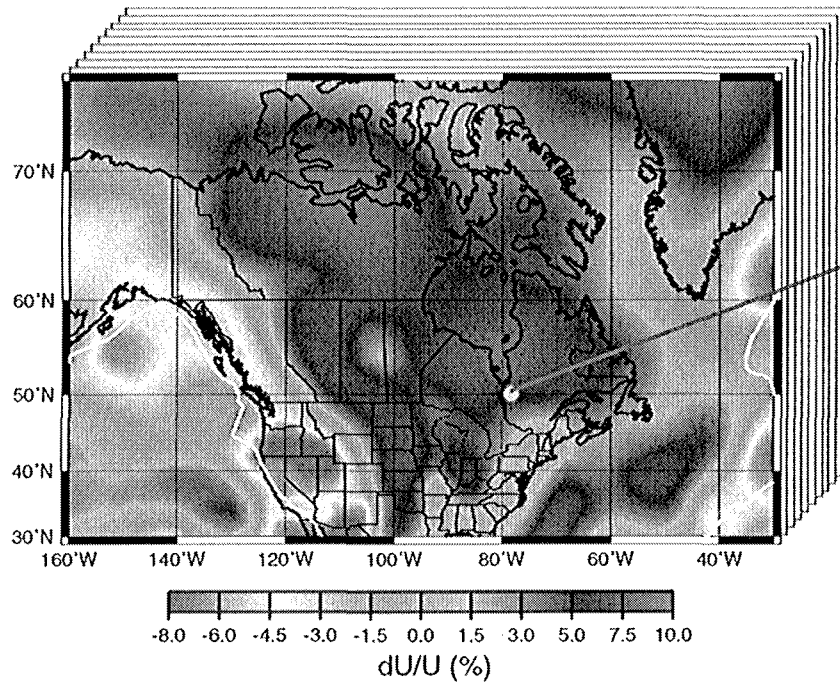

Monte-Carlo sampling of model space to find an ensemble of acceptable models

C. Details of the inversion: seismic parameterization

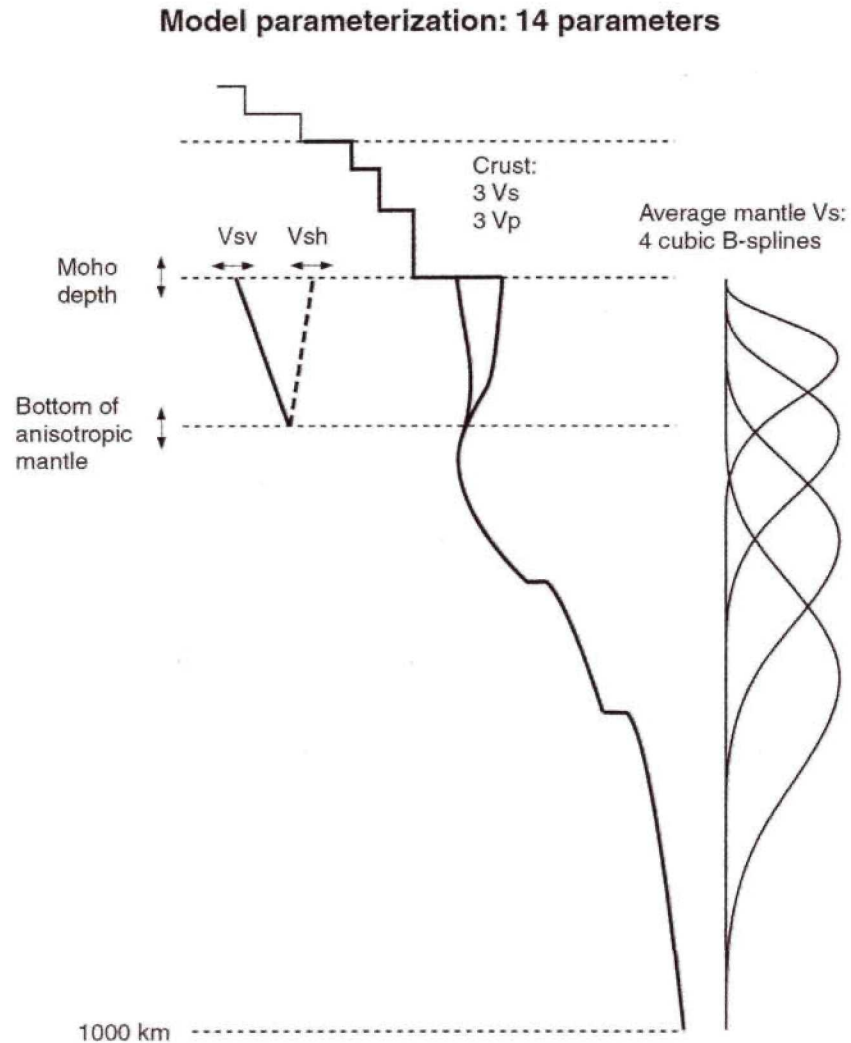

1. Ad-hoc combination of layers and B-splines
2. Seismic model is slightly over-parameterized
3. Non-physical vertical oscillations

Physically motivated parameterization is required

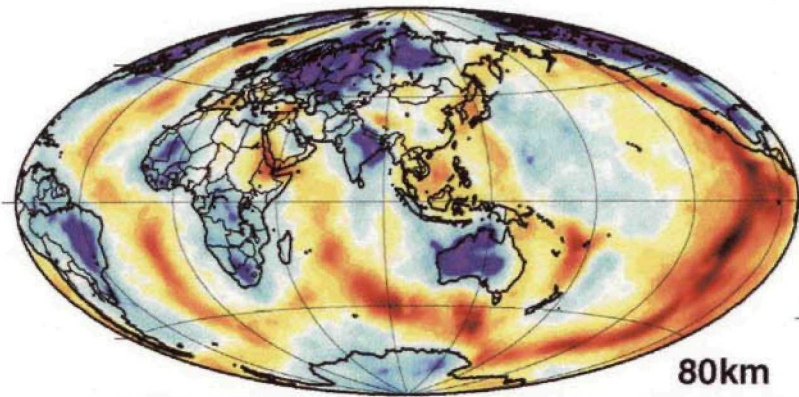

80km

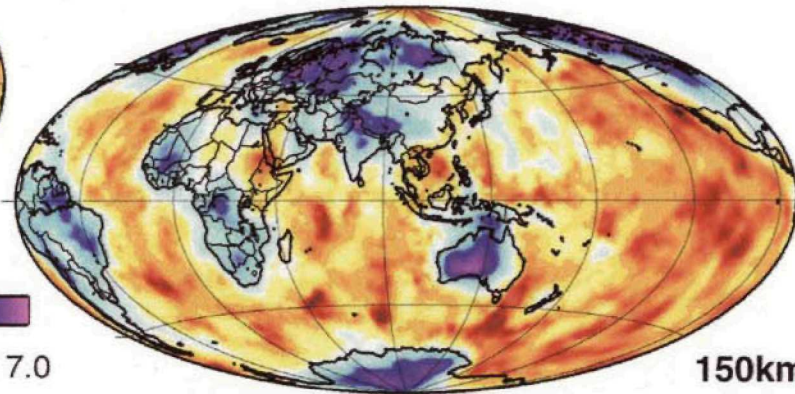
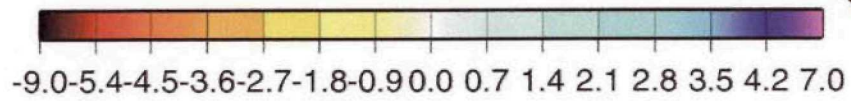

150km

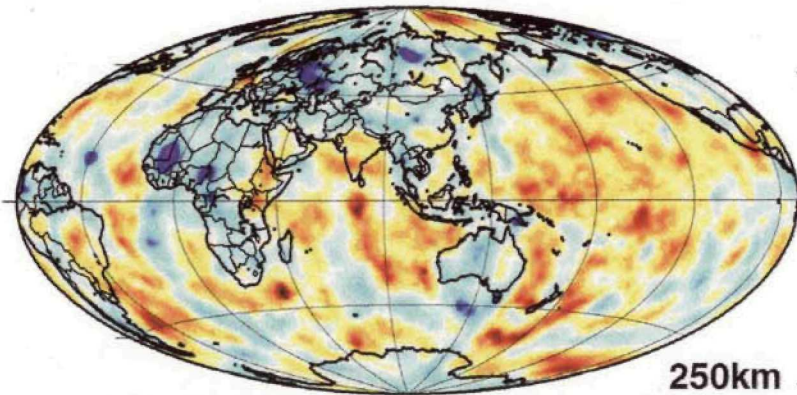
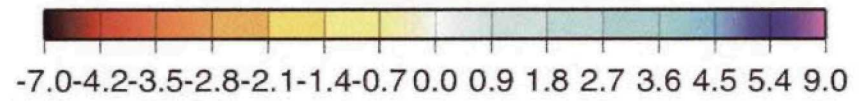

250km

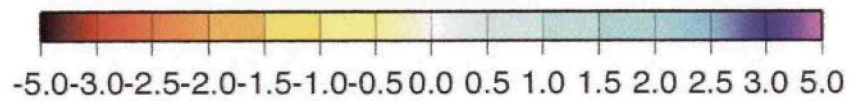

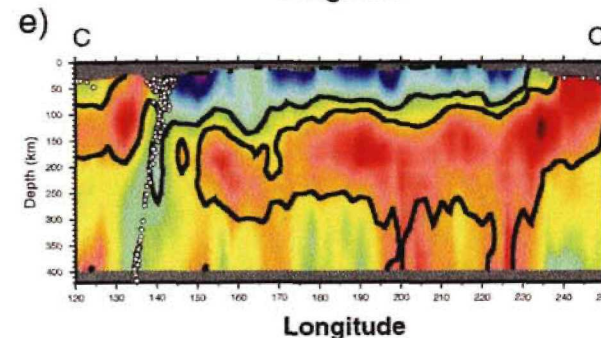
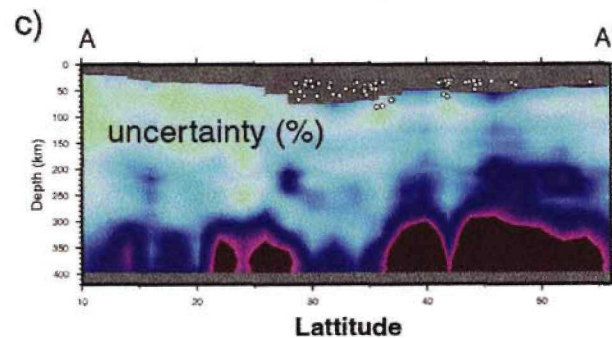
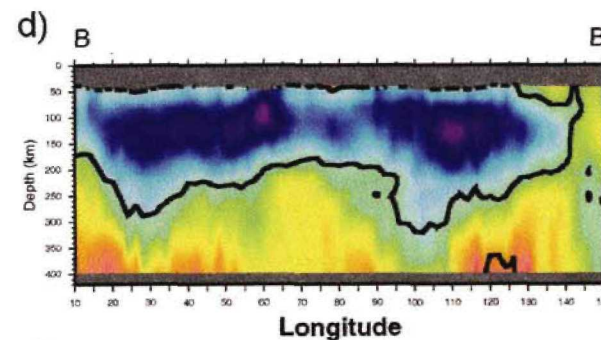
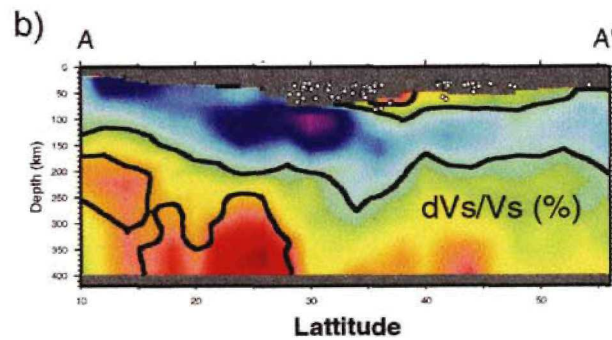
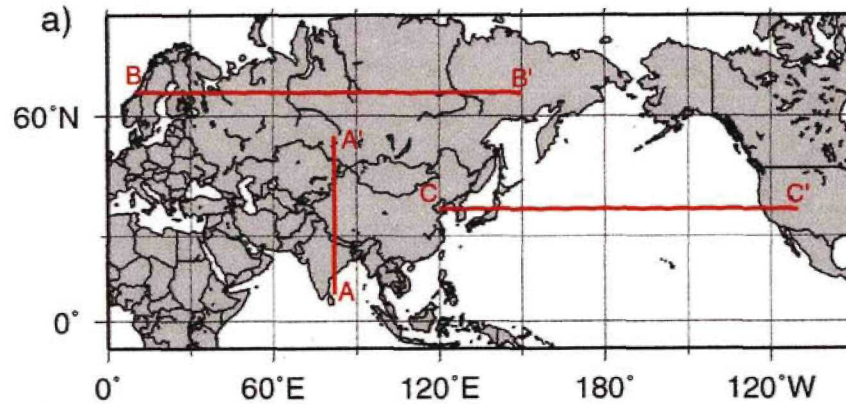

Middle of the ensemble of acceptable models is plotted.

Features found in every member of the ensemble of acceptable models are called “persistent”.

Persistent features are circled in black.

In some cases we may have good reasons not to believe some persistent features (later).

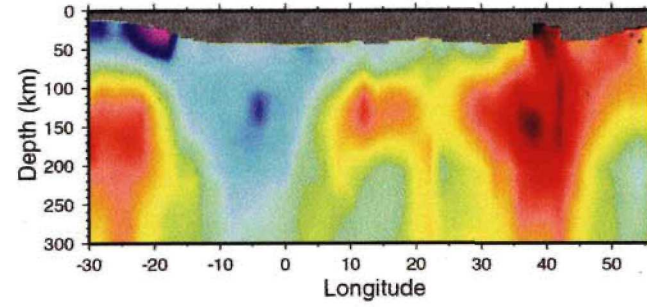
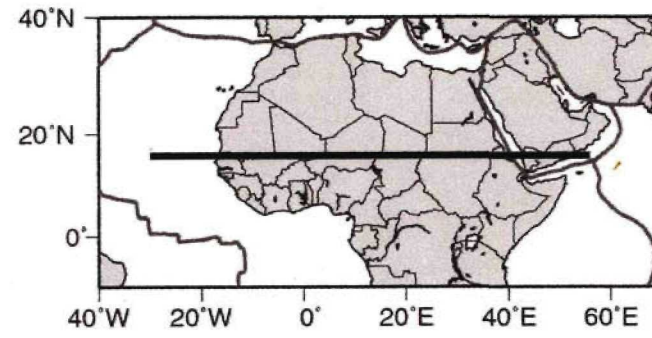
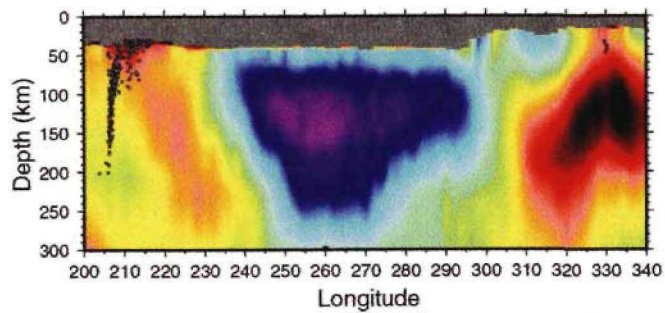
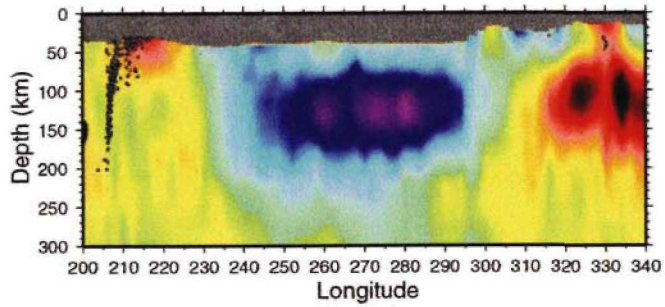
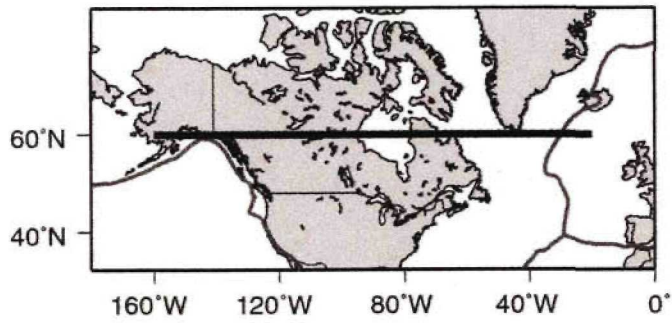

ray
theory

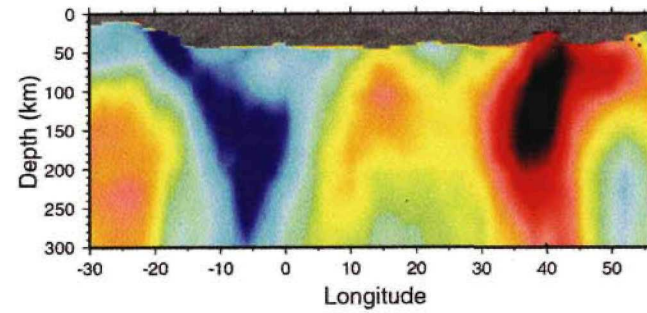

diffraction
theory

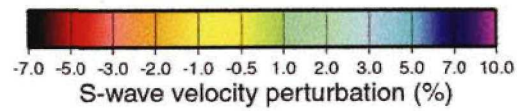

4. Applying A Priori Information and Physical Constraints

Fundamental Observation:

Can't get very far in any real problem without applying a priori information; i.e., information in addition to what measurements alone tell you.

Hierarchy of a priori Information:

- + discretization & judicious choice of basis functions
- + regularization: choice of a penalty function
 - data fit + smoothness + norm +
- + **physical constraints:** based on previous (imperfect) knowledge about structures or processes in area of study, may not be about the variables directly related to data.

The Idea in the Abstract

Seismic Model Space

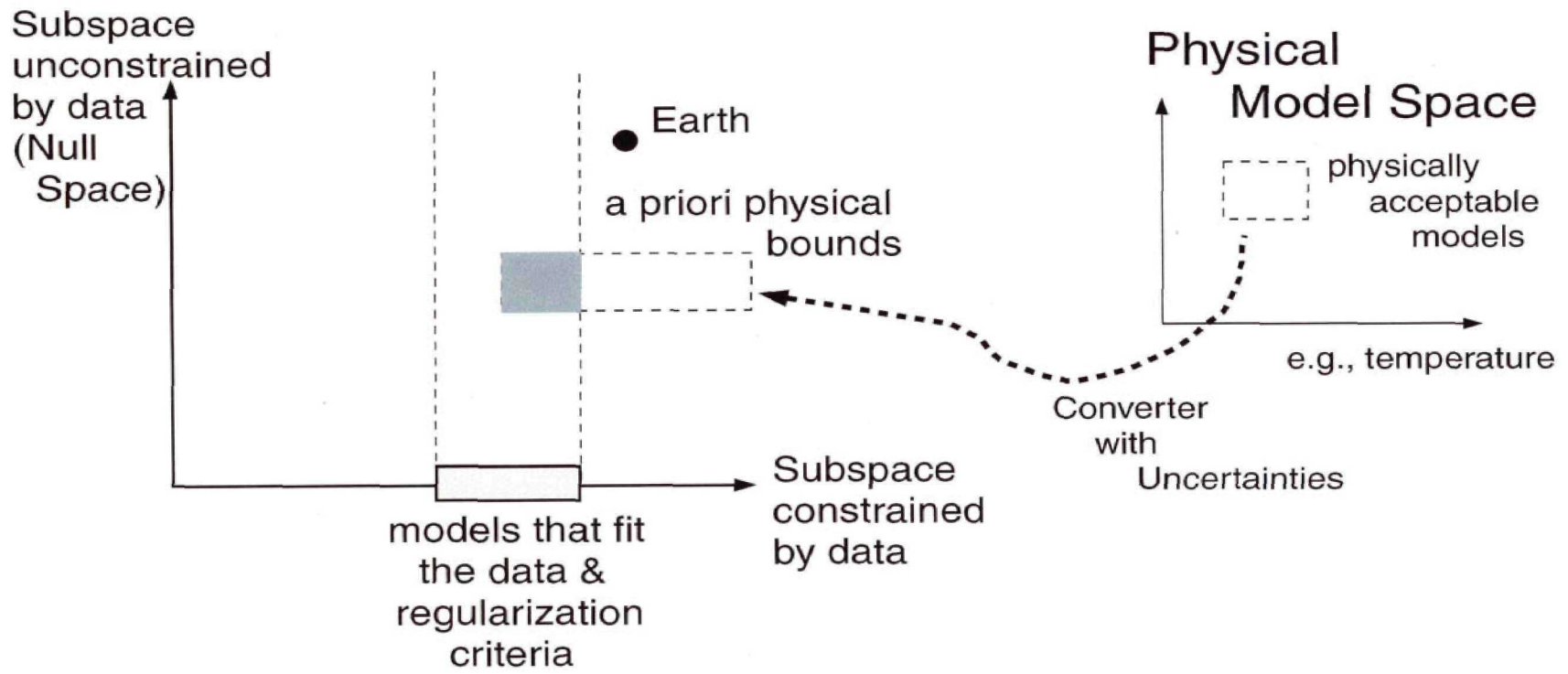

Motivation for Applying Physical Constraints in the Seismic Inversion

1. Seismic models that result from data and ad hoc a priori constraints are simply limited in their ability to model the Earth. Important physics may be in the "**null-space**" of seismic data. We want to control the null-space component of our models.
2. The seismic model possesses features, even persistent features, that are physically questionable.
3. Systematic errors in the measurements, the model of wave propagation, or (non-physical) a priori information may bias the model persistently.
4. Imposing physical a priori information may improve the seismic model's reliability and reduce uncertainties (improves confidence).
5. Information from the improved seismic model can be fed-back into the physical model to test and calibrate existing knowledge.

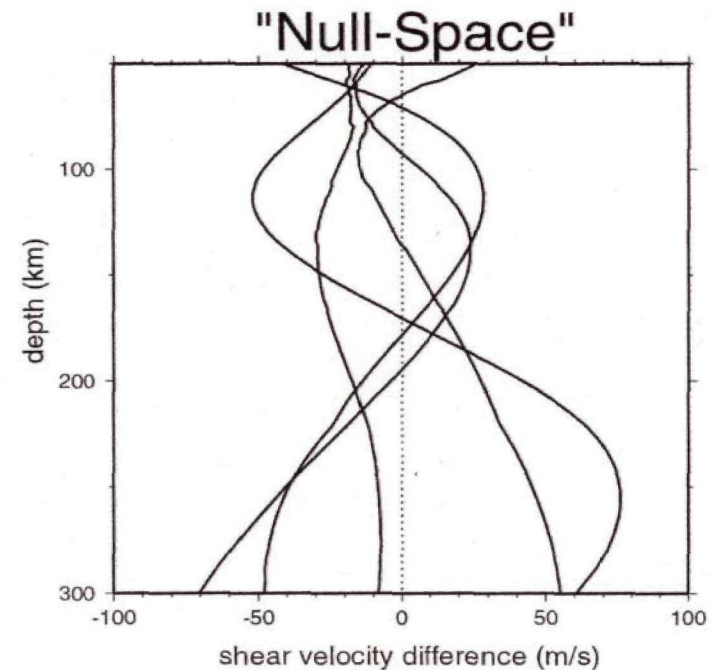

Discuss Two Types of a priori Physical Constraints

a. Thermal Data

+ Simultaneously fit heat flux data and seismic dispersion measurements.

+ Requires working in temperature and seismic wave speed spaces simultaneously.

b. Explicit Physical Constraints

+ a. Thermal steady-state constraint beneath cratons (very old continental regions).

+ b. Thermal cooling constraint beneath oceans.

Conversion between seismic velocity and temperature

Computed with the method of Goes et al. (2000) using laboratory-measured thermo-elastic properties of the principal mantle minerals and a model of mantle composition.

$$\begin{aligned} \mu(P, T, X) &= \mu_0 + (T - T_0) \frac{\partial \mu}{\partial T} + (P - P_0) \frac{\partial \mu}{\partial P} + X \frac{\partial \mu}{\partial X} \\ K(P, T, X) &= K_0 + (T - T_0) \frac{\partial K}{\partial T} + (P - P_0) \frac{\partial K}{\partial P} + X \frac{\partial K}{\partial X} \\ \rho(P, T, X) &= \rho_0(X) \left[1 - \alpha(T - T_0) + \frac{(P - P_0)}{K} \right] \\ \rho_0(X) &= \rho_0 \left|_{X=0} + \frac{\partial \rho}{\partial X} \end{aligned}$$

$$\alpha(T) = \alpha_0 + \alpha_1 T + \alpha_2 T^{-1} + \alpha_3 T^{-2}$$

ρ - density
 μ - shear modulus
 K - bulk modulus
 T - temperature
 P - pressure
 X - iron content
 α - coefficient of thermal expansion

Following parameters are defined from laboratory experiment:

$$\rho_0 \left|_{X=0}, \mu_0, K_0, \frac{\partial \rho}{\partial X}, \frac{\partial \mu}{\partial X}, \frac{\partial K}{\partial X}, \frac{\partial \mu}{\partial T}, \frac{\partial K}{\partial T}, \frac{\partial \mu}{\partial P}, \frac{\partial K}{\partial P}, \alpha_0, \alpha_1, \alpha_2, \alpha_3$$

Voigt-Reuss-Hill averaging for a combination of minerals:

$$\langle \rho \rangle = \sum \lambda_i \rho_i$$

$$\langle \mu \rangle = \frac{1}{2} \left[\sum \lambda_i \mu_i + \left(\sum \frac{\lambda_i}{\mu_i} \right)^{-1} \right]$$

$$\langle K \rangle = \frac{1}{2} \left[\sum \lambda_i K_i + \left(\sum \frac{\lambda_i}{K_i} \right)^{-1} \right]$$

λ_i is the volumetric proportion of mineral i

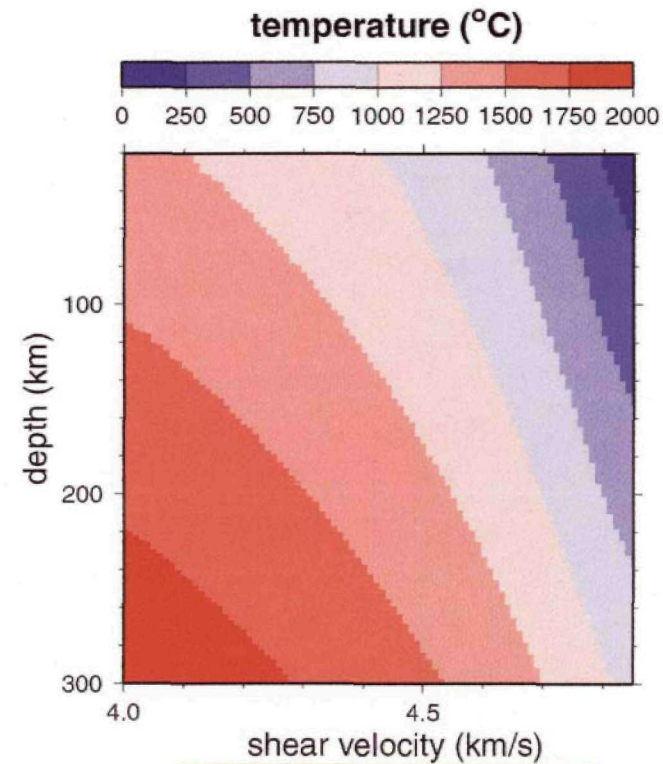

4.a Apply Heat Flux Constraint on Inversion for the Cratonic Upper Mantle

- Background on thermal structure of the upper mantle under old continents (cratons), and limitations.
- Problems with using seismic models to infer temperature.
- Monte-Carlo joint inversion of heat flux and seismic data. (Work in both seismic and temperature spaces.)
- 4.a.1 Reformulate problem with explicit physical constraints on the temperature field in the uppermost mantle.
- 4.a.2 Results on mantle heat flux and lithospheric thickness for Canada.

Thermal models of the old continental lithosphere

from Jaupart and Mareschal (1999)

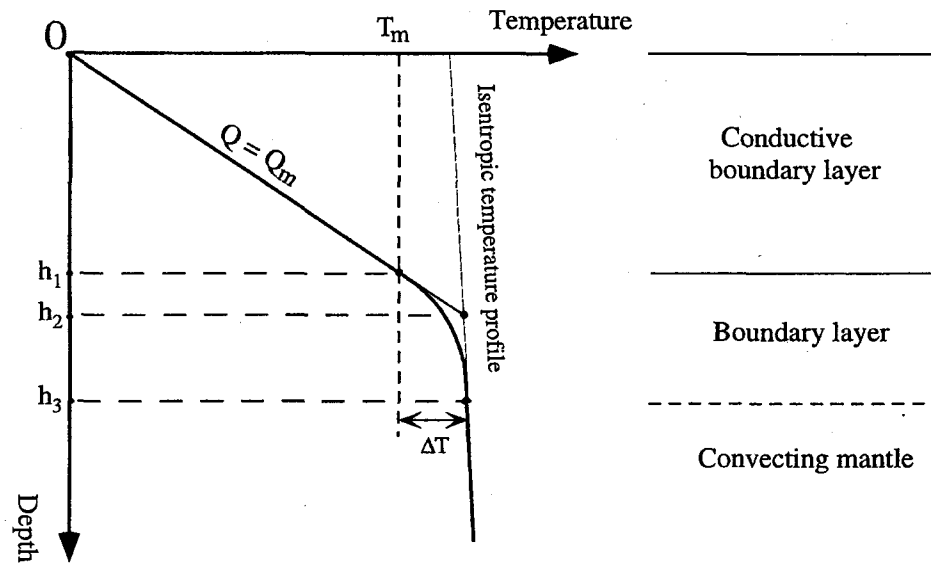

from Poupinet et al. (2003)

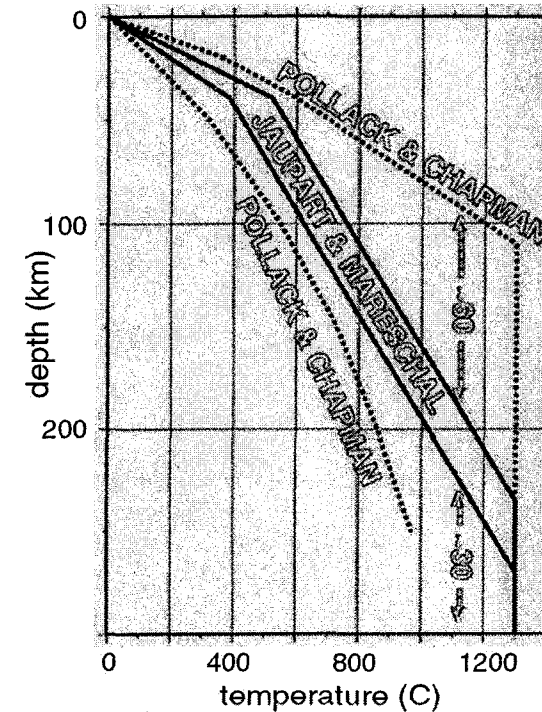

1. Constrained by thermal data: heat flow, xenoliths.
2. Derived from simple thermal equations.
3. Lithosphere is defined as an outer conductive layer.
4. Estimates of thermal lithospheric thickness are highly variable.

Seismic models of the old continental lithosphere

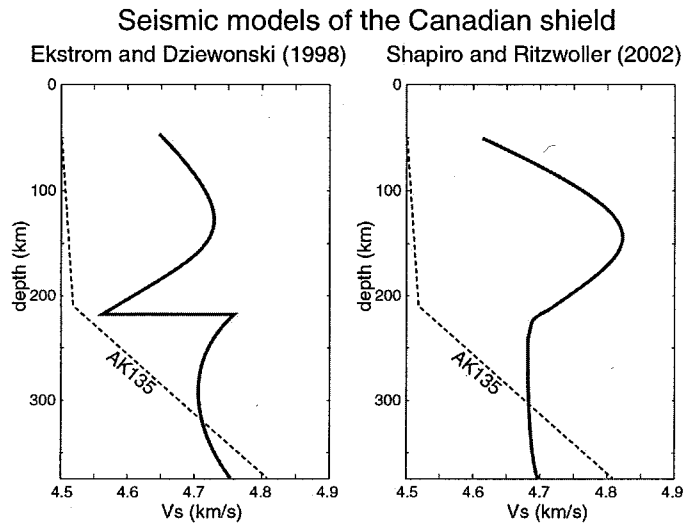

Temperature estimated from the seismic model
of Shapiro and Ritzwoller (2002)

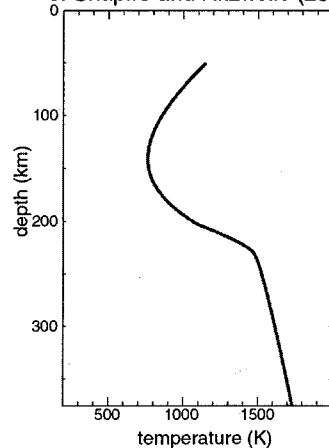

1. Based on ad-hoc choice of reference 1D model and parameterization.
2. Complex vertical profiles that do not agree with simple thermal models.
3. Seismic lithospheric thickness is not uniquely defined.

Additional physical constraints are required to eliminate non-physical vertical oscillations in seismic profiles and to improve estimates of seismic velocities at each particular depth

Monte-Carlo inversion of the seismic data constrained by heat flux data

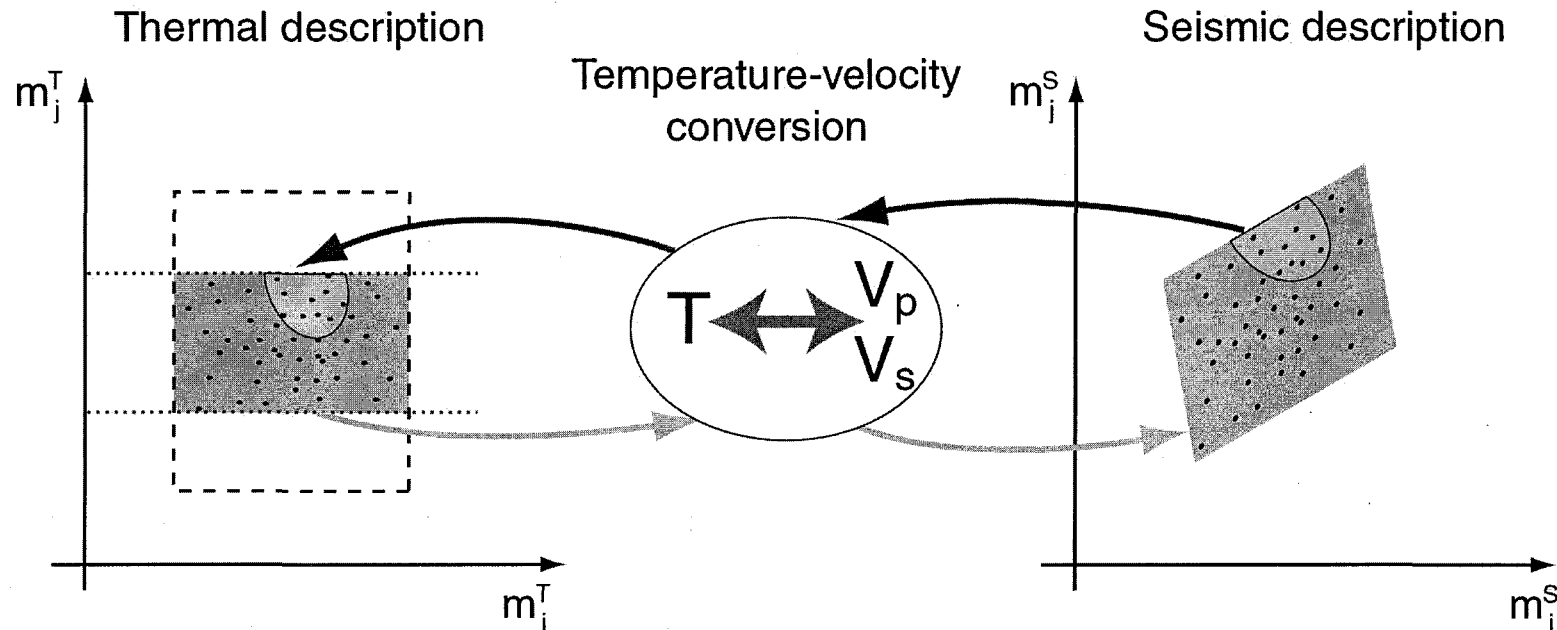

1. a-priori range of physically plausible thermal models
2. constraints from thermal data (heat flow)
3. randomly generated thermal models
4. converting thermal models into seismic models
5. finding the ensemble of acceptable seismic models
6. converting into ensemble of acceptable thermal models

Inversion with the seismic parameterization

seismically

acceptable models

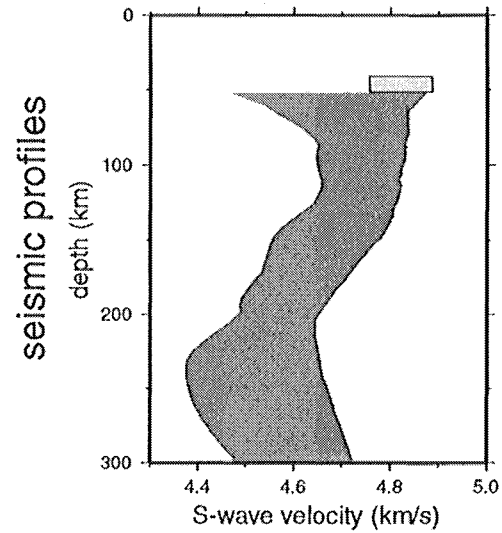

models that satisfy
the heat-flow constraint

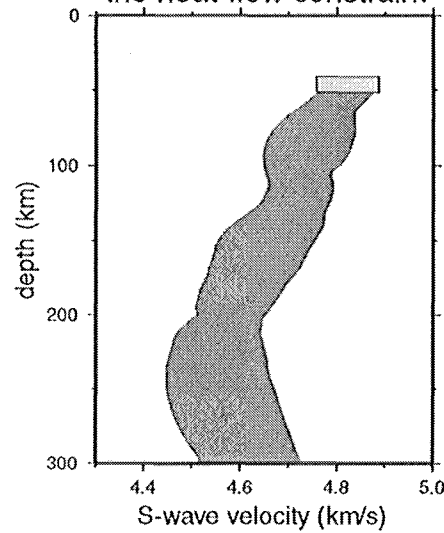

models that do not satisfy
the heat-flow constraint

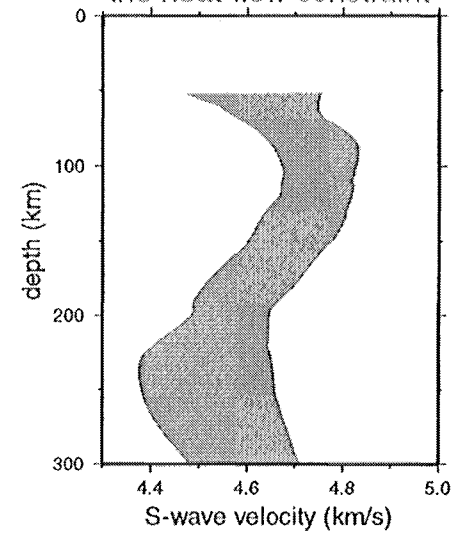

temperature profiles

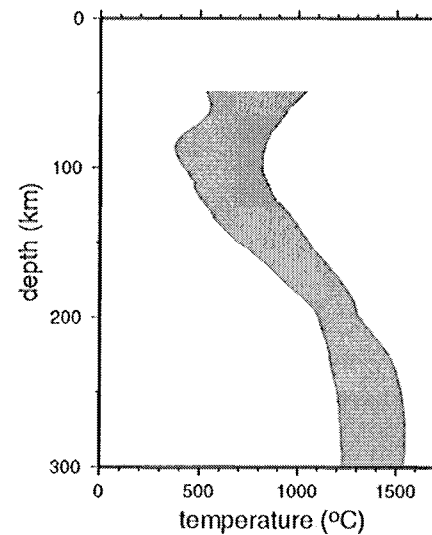
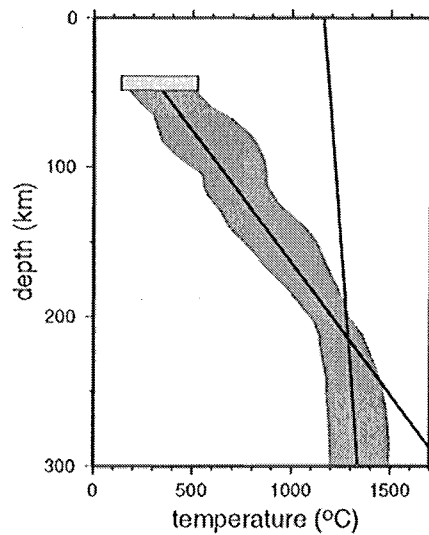
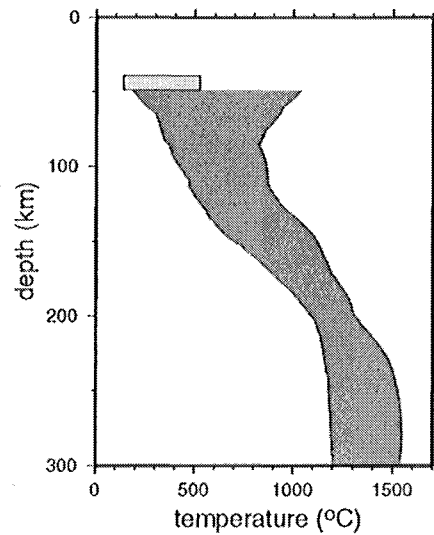

First Example of a Physical Constraint: Steady-State Thermal Model of the Old Continental Uppermost Mantle

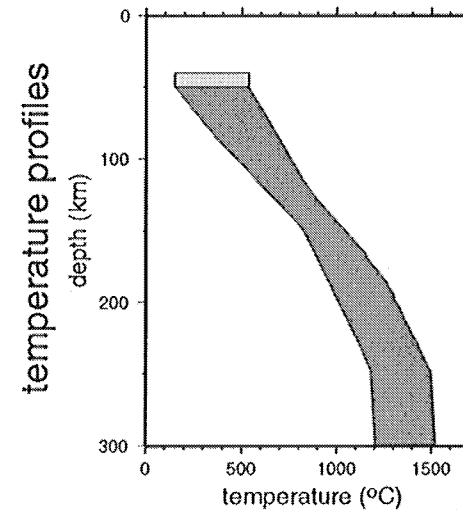
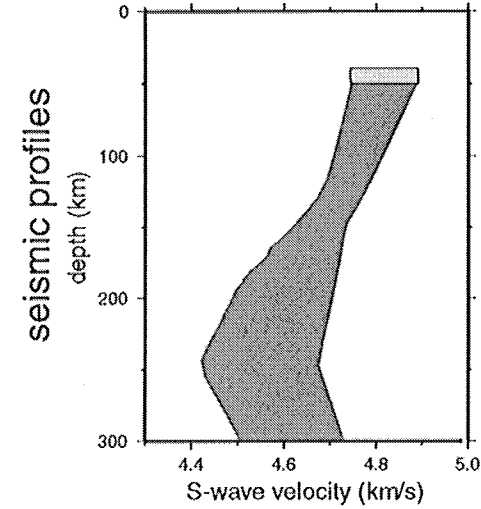
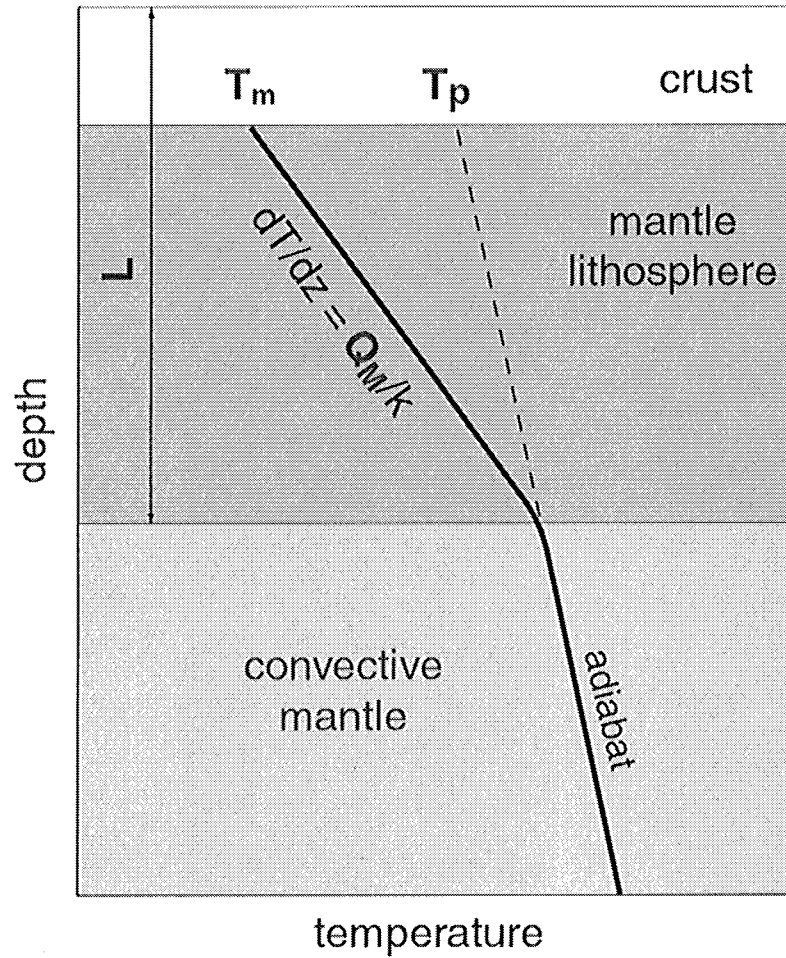

Lithospheric thickness and mantle heat flow

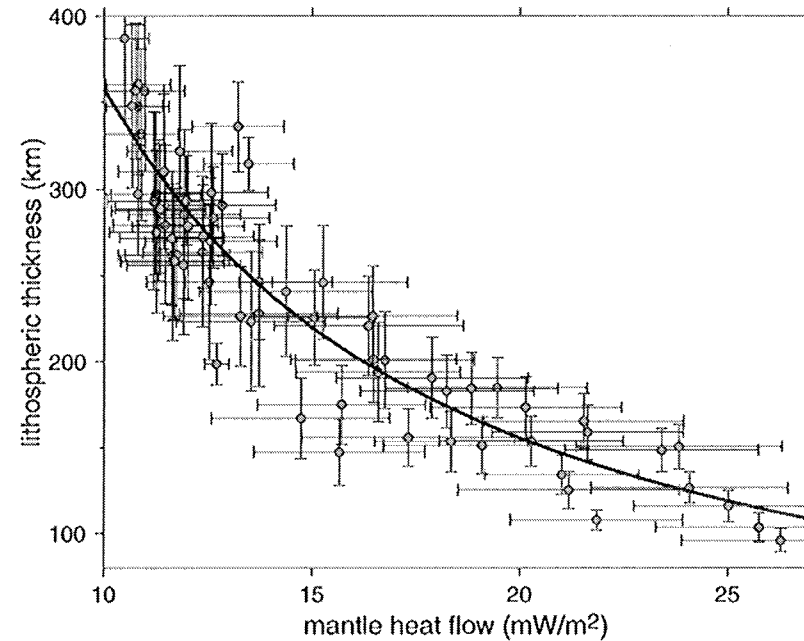
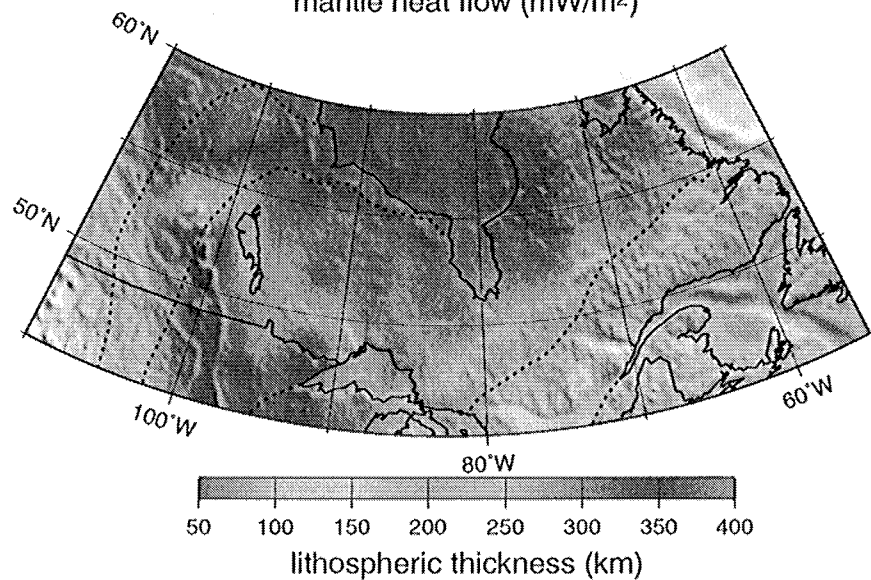
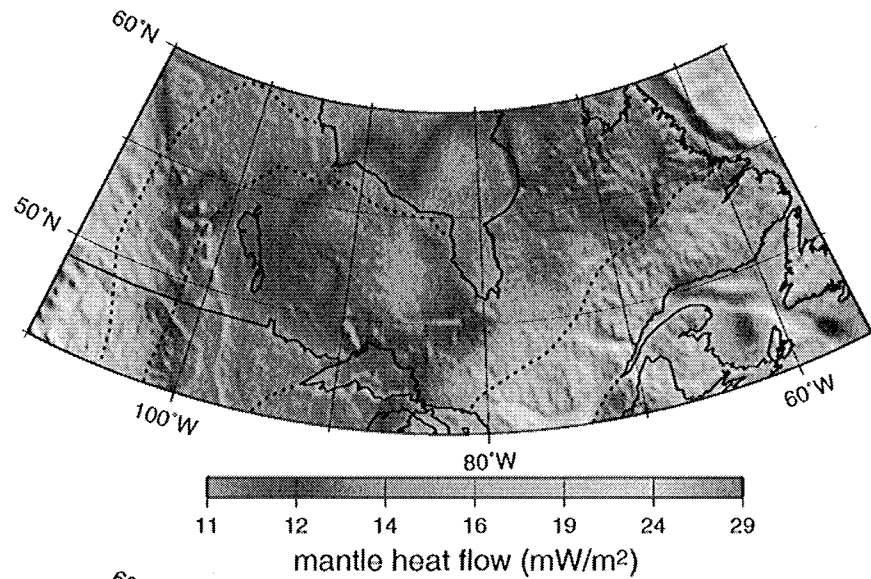

Power-law relation between lithospheric thickness and mantle heat flow is consistent with the model of Jaupart et al. (1998) who postulated that the steady heat flux at the base of the lithosphere is supplied by small-scale convection.

4.a Conclusions

1. Seismic surface-waves and surface heat flow data can be reconciled over broad continental areas; i.e., both types of observations can be fit with a simple steady-state thermal model of the upper mantle.
2. Seismic inversions can be reformulated in terms of an underlying physical model.
3. The estimated lithospheric structure is not well correlated with surface tectonic history.
4. The inferred relation between lithospheric thickness and mantle heat flow is consistent with geodynamical models of stabilization of the continental lithosphere (Jaupart et al., 1998).

4.b Physical Constraint on Temperature Structure in the Uppermost Oceanic Mantle

- Simple hypothesis concerning temperatures in the oceanic upper mantle: half-space cooling, “Standard Model” of the cooling of the oceanic upper mantle.
- Testing the Standard Model. Does the Pacific upper mantle cool continuously, consistent with the Standard Model?
- Reformulate inversion keeping this question in mind. Look for deviation from simple cooling.
- Result: Cooling from 0-70 Ma & 100-135 Ma (on average), bracketing an era of reheating in the Central Pacific (70 - 100 Ma).
- Cause of reheating in the Central Pacific? Thermal Boundary Layer Instabilities or Small-Scale Convection.

Standard Model of the Thermal Evolution of Oceanic Lithosphere

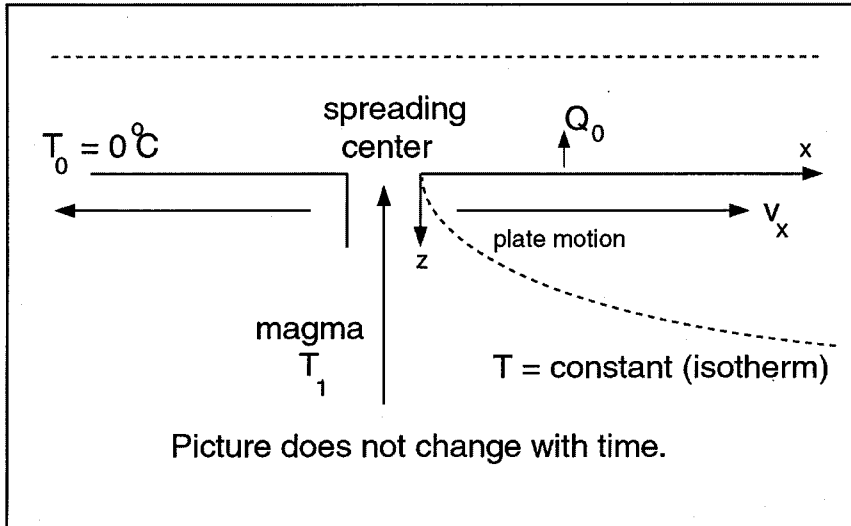

Thermal diffusion equation

$$\frac{dT}{dt} = \kappa \nabla^2 T + A$$

$$\frac{\partial T}{\partial t} + \vec{v} \cdot \nabla T = v_x \frac{\partial T}{\partial x} = \kappa \frac{\partial^2 T}{\partial z^2}$$

Assumed:

Lithospheric Age:

1. No internal heat source.
2. Process is stationary.
3. Motions are purely horizontal.
4. Ignore horizontal heat diffusion.

$$\tau = \frac{x}{v_x}$$

$$\frac{\partial T}{\partial \tau} = \kappa \frac{\partial^2 T}{\partial z^2}$$

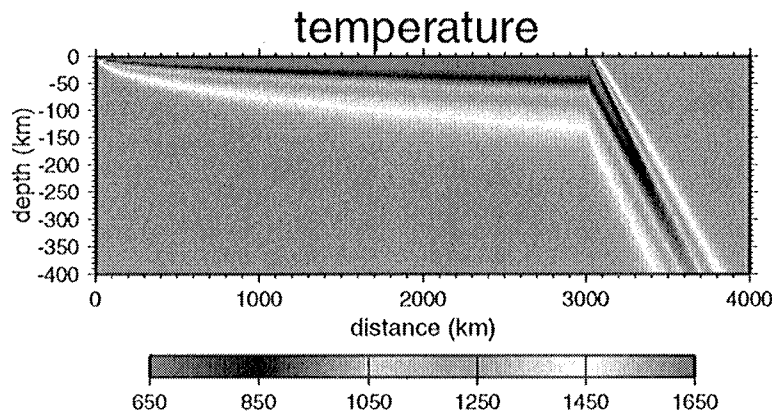

$$T(z, \tau) = T_1 \text{erf}\left(\frac{z}{2\sqrt{\kappa\tau}}\right) \sim \tau^{1/2}$$

$$Q_0(\tau) = k \left(\frac{\partial T}{\partial z}\right)_0 = \frac{kT_1}{\sqrt{\pi\kappa\tau}} \sim \tau^{-1/2}$$

Standard Model of the Thermal Evolution of Oceanic Lithosphere (cont.)

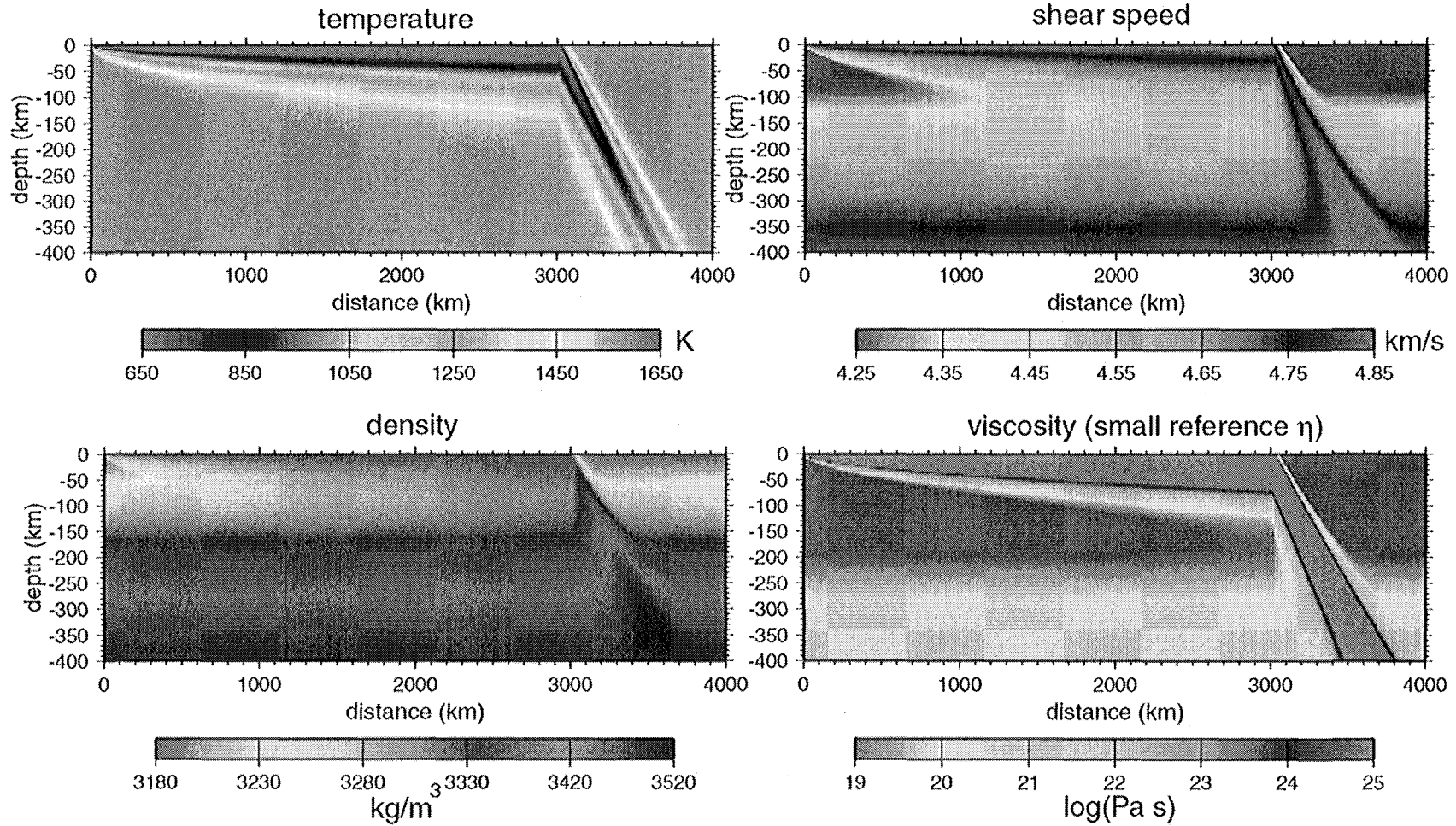

Specifying the Physical Constraint in Temperature Space

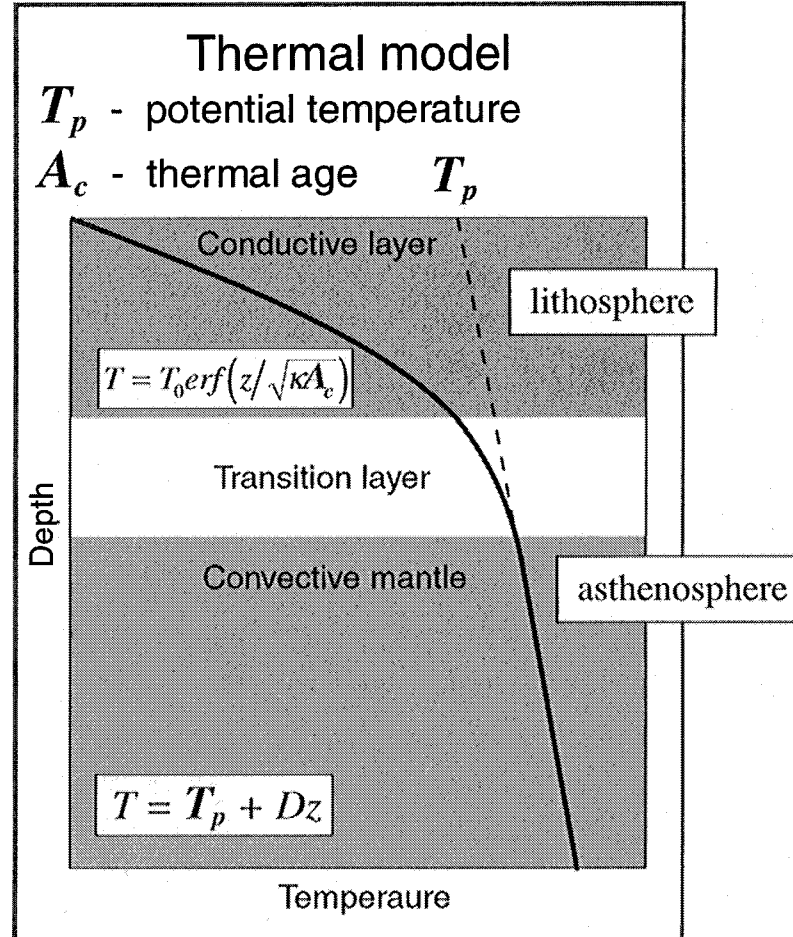
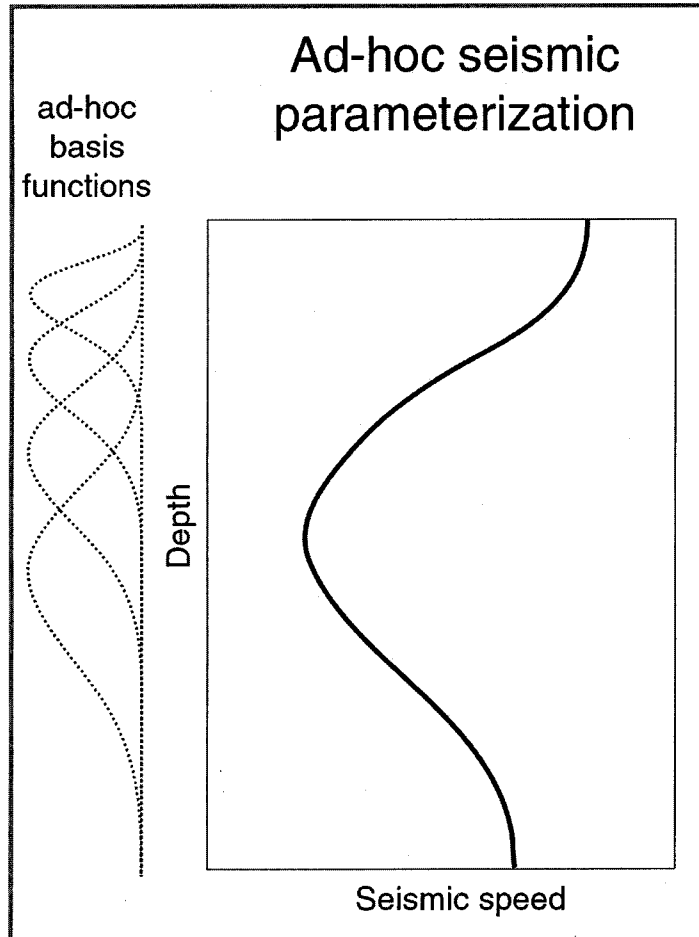

Effect of the Physical Constraint

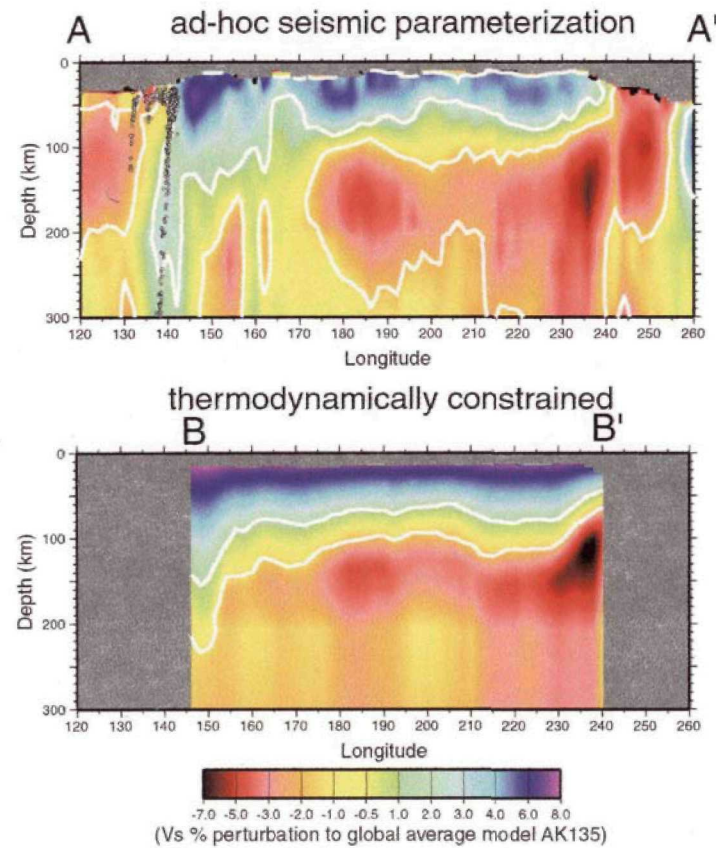
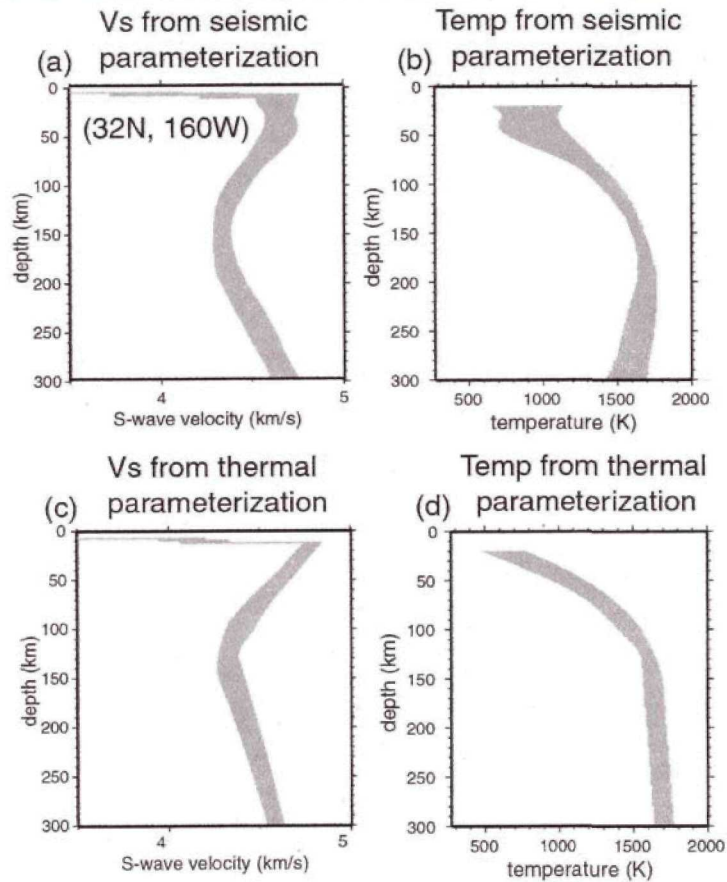
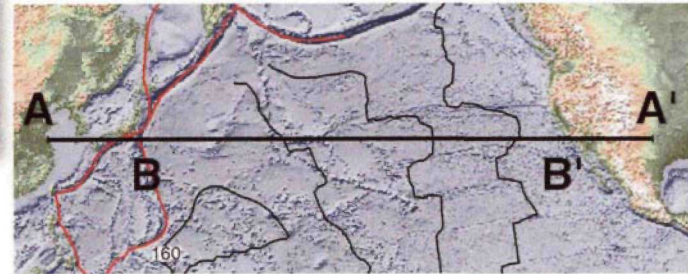

apparent thermal age

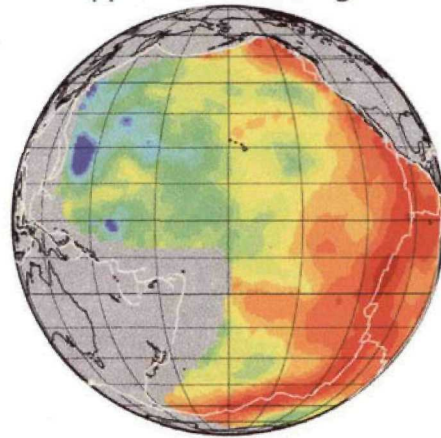

lithospheric age

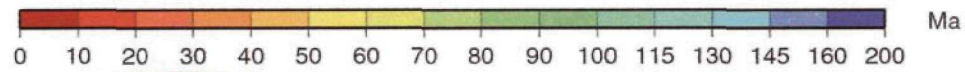
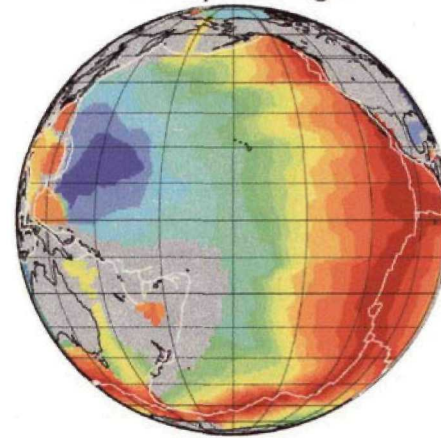

difference:
thermal-lithospheric
age

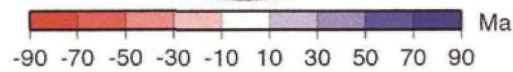
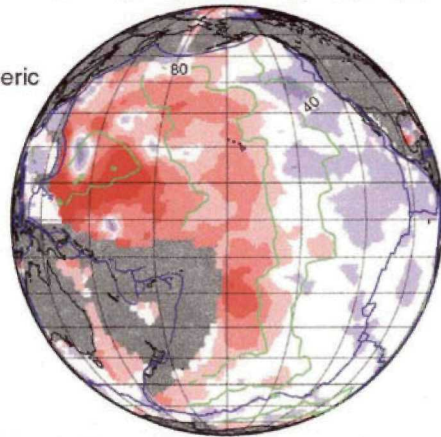

Two-Stage Cooling

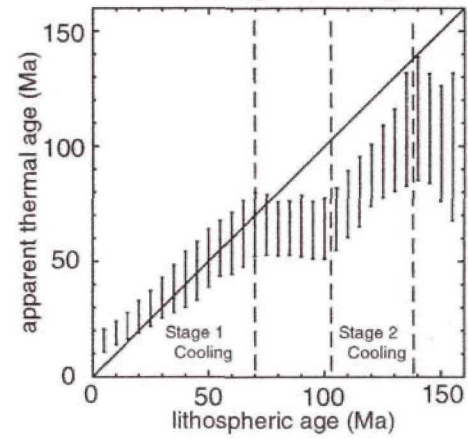

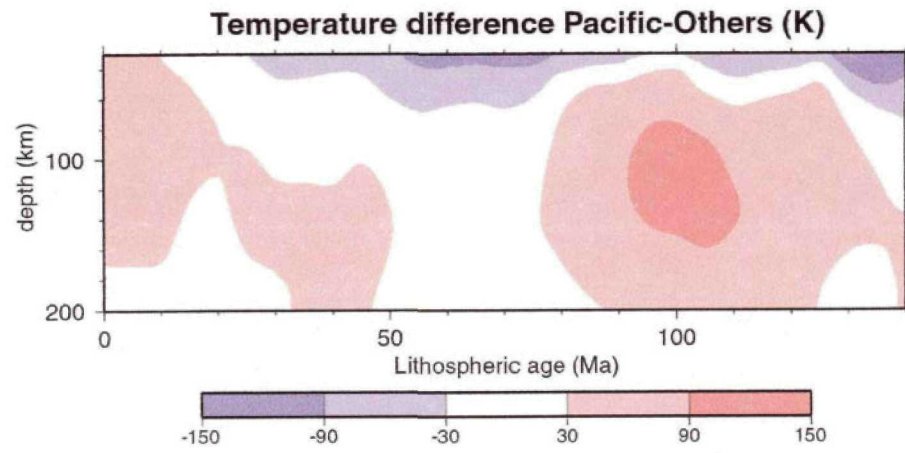
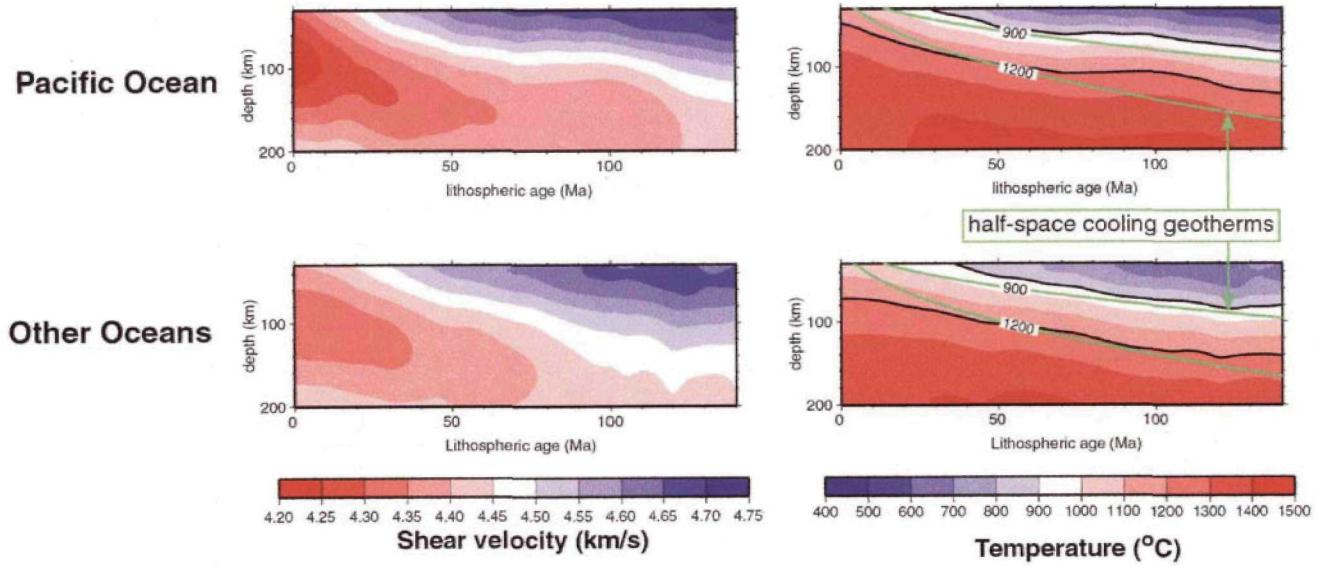

Causes(s) of the Two-Stage Cooling of the Pacific Lithosphere?

Initial conditions.

Small-scale, deep-seated processes: plumes.

Large-scale, deep-seated processes: global convection.

Small-scale, shallow processes: lithospheric instabilities, small-scale convection (Richter rolls).

Shijie Zhong
Jeroen van Hunen
Jinshui Huang

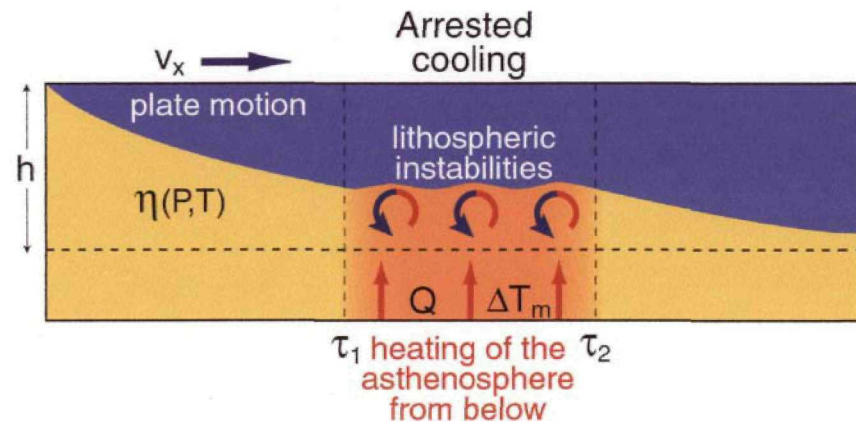

Two Modes of Convection

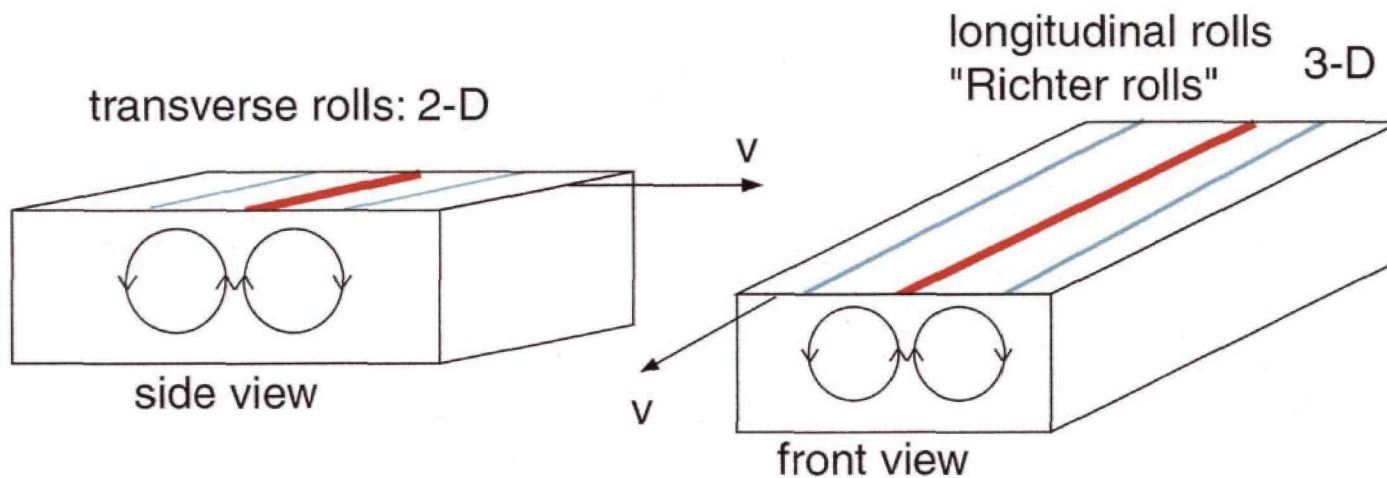

The nature and vigor of convection is very different:

- Richter rolls are more energetic, so they dominate 3-D simulations. (As Richter argued in 1974!)
- Richter rolls more efficiently remove heat from the lithosphere.

Views of 3-D Convection Simulation of Richter Rolls

Zhong, van Hunen, Huang

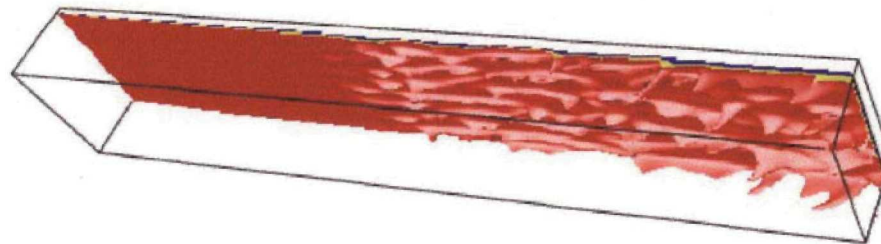
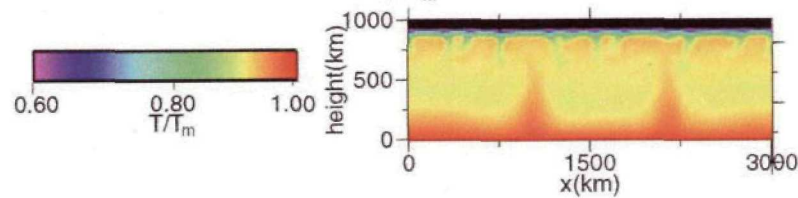
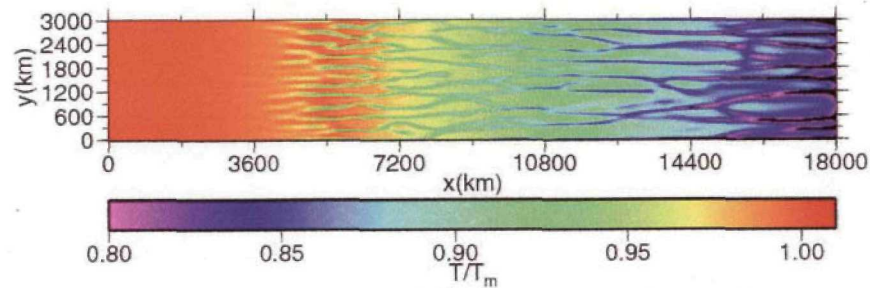

Summary of the Small-Scale Convection Simulations, to Date

1. Longitudinal (Richter) rolls are more vigorous than transverse rolls.
2. Vigor of both modes depends on plate speed v :
 - longitudinal increases with v
 - transverse decreases with v
3. Both modes of convection set on at a characteristic time.
4. Vigor of convection maximizes right after on-set, and diminishes thereafter.

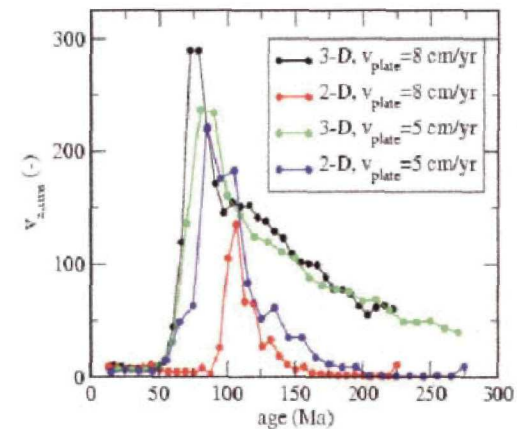

5. Transverse rolls only impart transient heating to the lithosphere.
6. Longitudinal rolls permanently heat the lithosphere, and the heating event is over a finite duration.

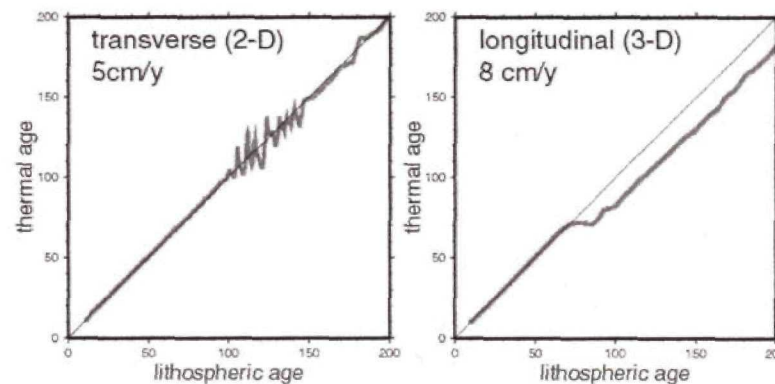

Summarizing Oceanic Results

1. Lithosphere is not cooling continuously: Two stages of cooling bracketing a period of heating/arrested cooling

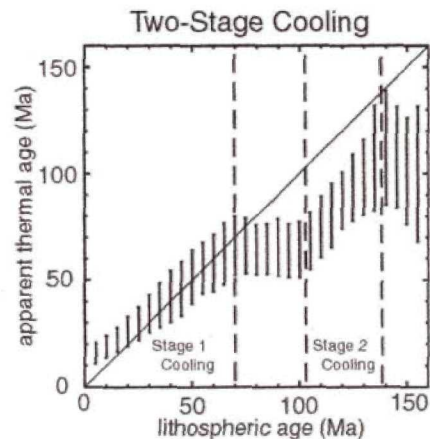

Stage 1: < 70 Ma
Heating/arrested cooling: 70 - 100 Ma
Stage 2: 100 - 135 Ma

2. Small-scale convection (Richter rolls) are expected to evolve thermally in a similar way.

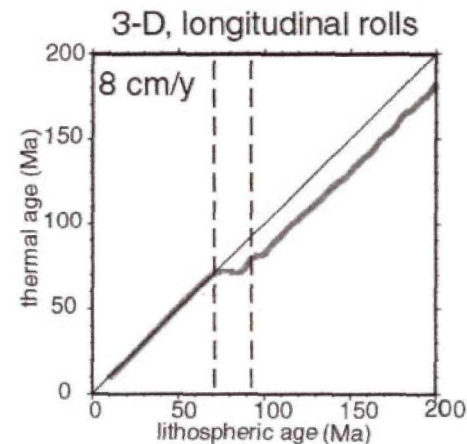

5. Dispersion measurements from the random wavefield

- Discussion of the “random wavefield”.
- Method to estimate Green functions & dispersion between stations.
- Proof-of-concept results.

Rayleigh wave group velocity (100 s)

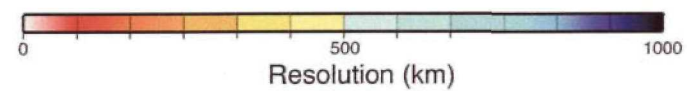
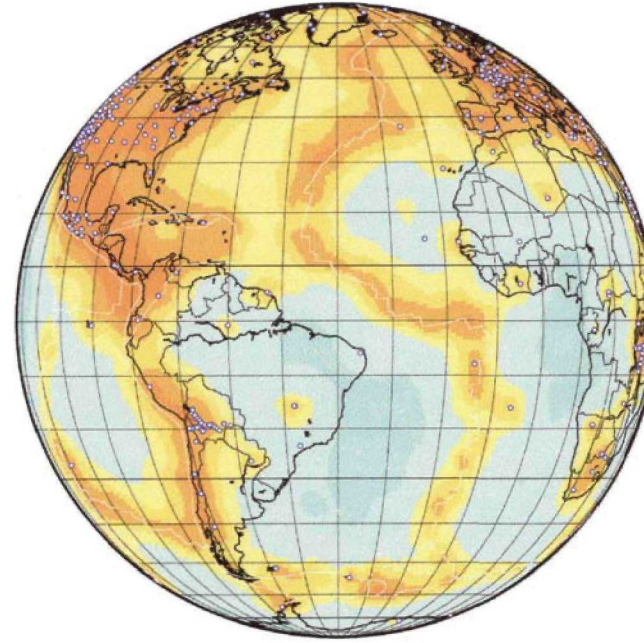
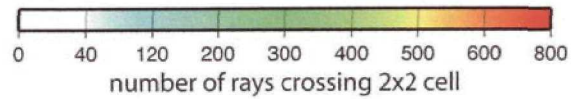
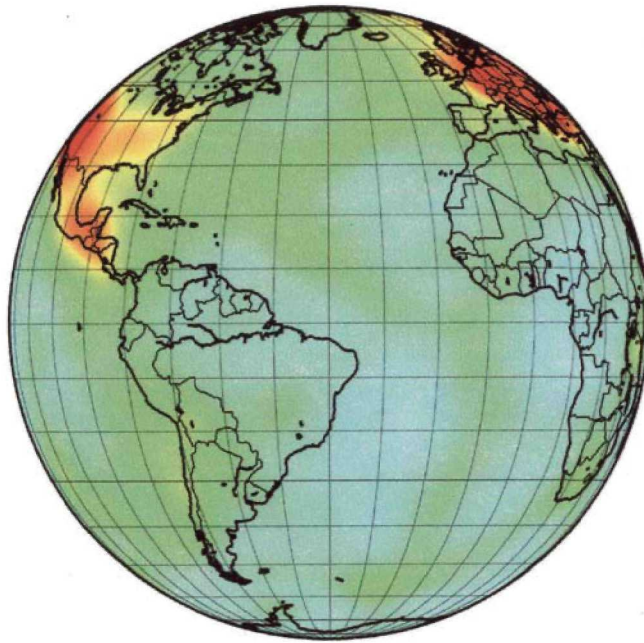

How can we improve the resolution?

✓ install more stations

new types of measurements

traditional approach:
using
teleseismic surface waves

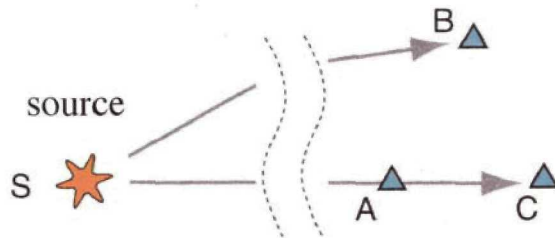

- extended lateral sensitivity
- sample only certain directions
- source dependent
- difficult to make short-period measurements

Consequence: **limited resolution**

Alternative solution:
making measurement from
random wavefield
(ambient seismic noise)

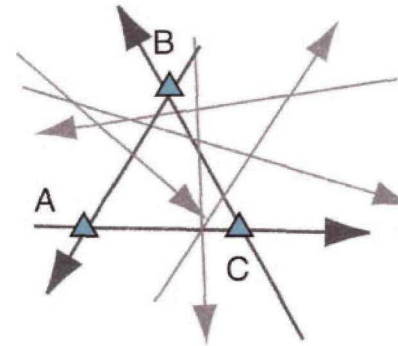

- localized lateral sensitivity
- samples all directions
- source independent
- may allow many short-period measurements

May improve resolution

one day of seismic record

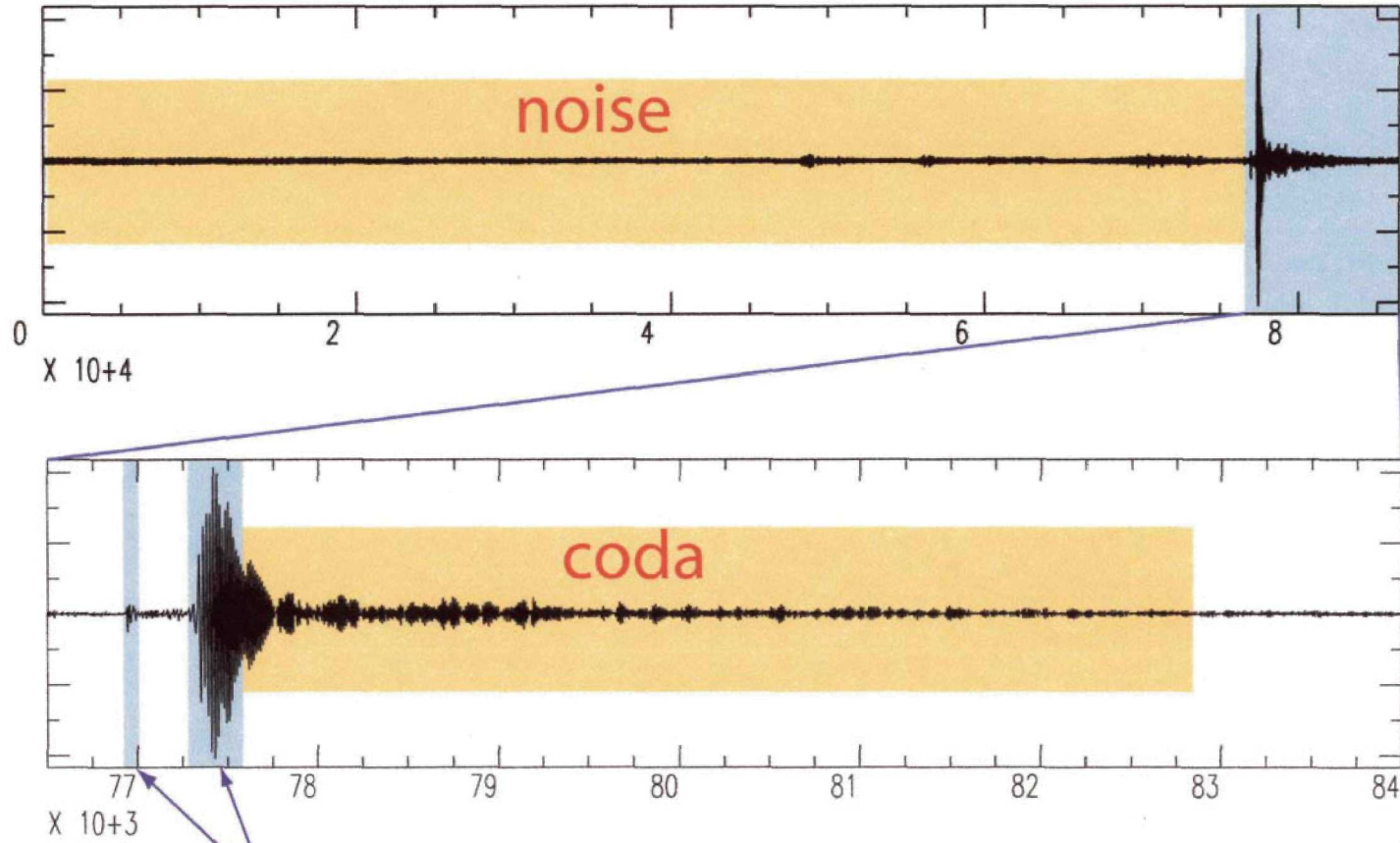

ballistic waves used in traditional tomography

Seismic coda and ambient seismic noise - random seismic wavefields

Coda - result of multiple scattering
on random inhomogeneities

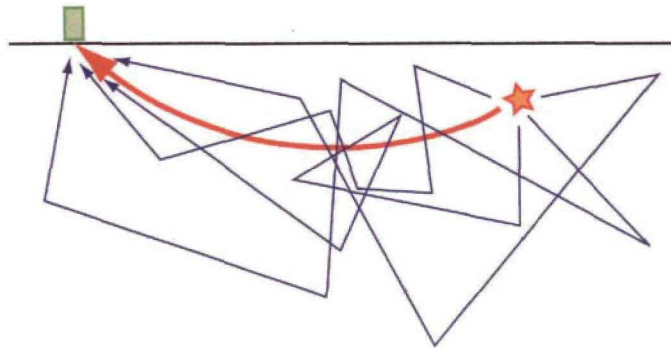

noise sources

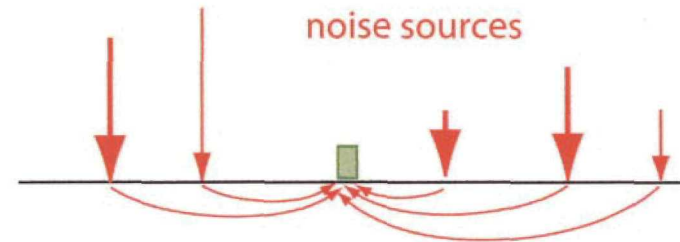

Noise - seismic waves emitted by
random ambient sources

Correlations of random wavefields

Random wavefield - sum of waves emitted by randomly distributed sources

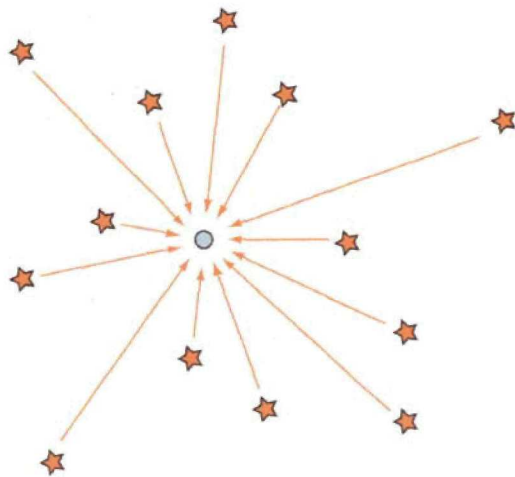

Cross-correlation of waves emitted by a single source between two receivers

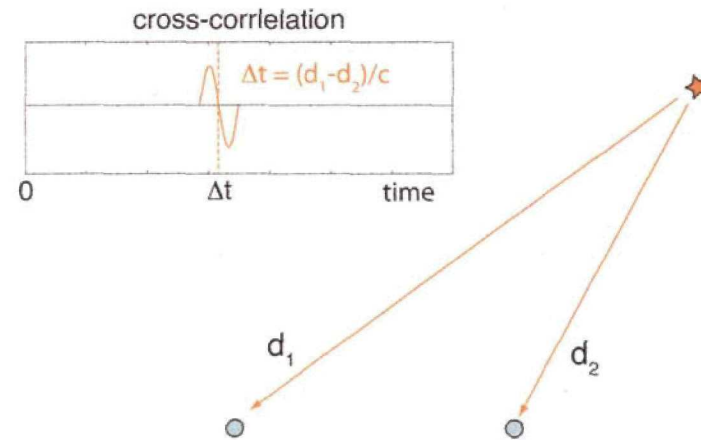

Correlations of random wavefields

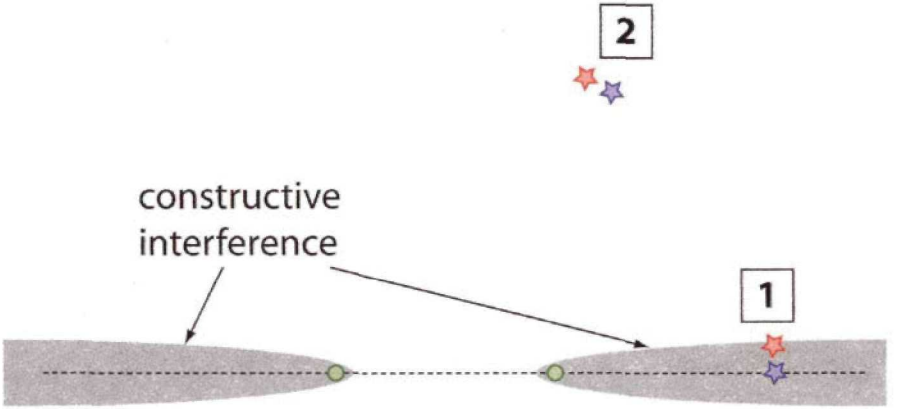

Sources are in constructive interference when respective travel time difference are close to each other

Effective density of sources is high in the vicinity of the line connecting two receivers

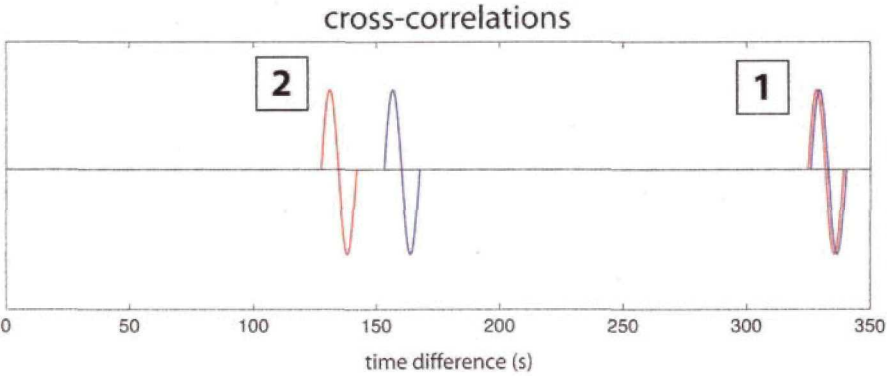

Cross-correlation extracts waves propagating along the line connecting two receivers

Cross-correlations of regional coda

From Campillo and Paul (2003)

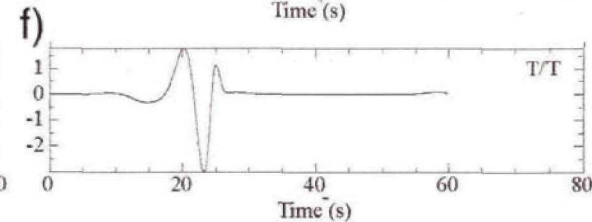
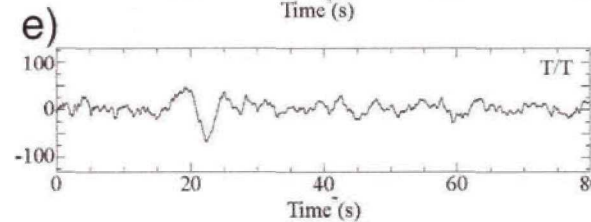
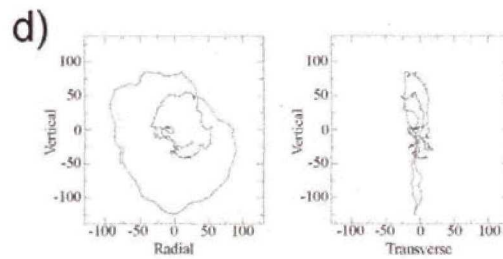
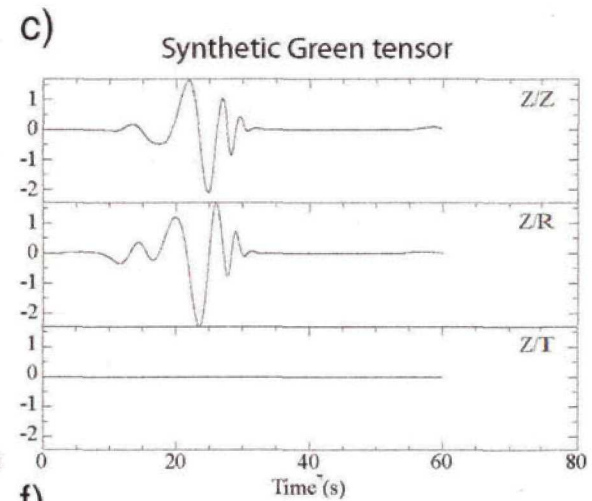
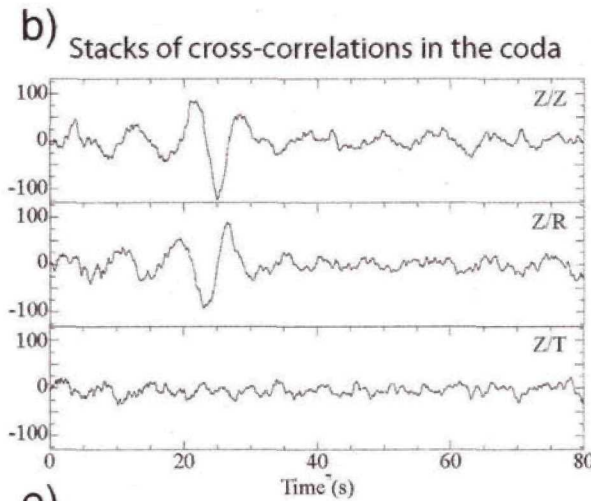
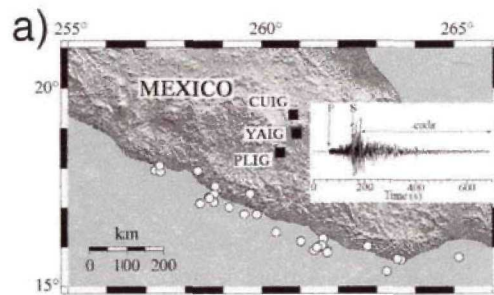

Cross-correlations from ambient seismic noise at US stations

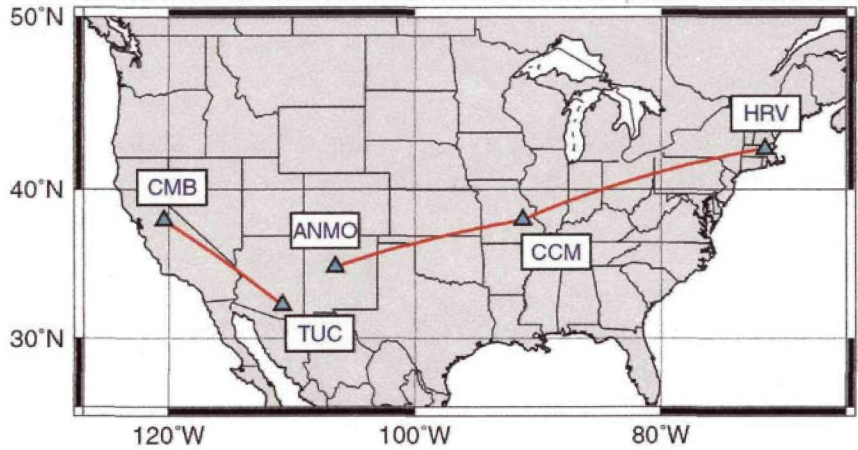

frequency-time analysis of broadband cross-correlations computed from 30 days of continuous vertical component records

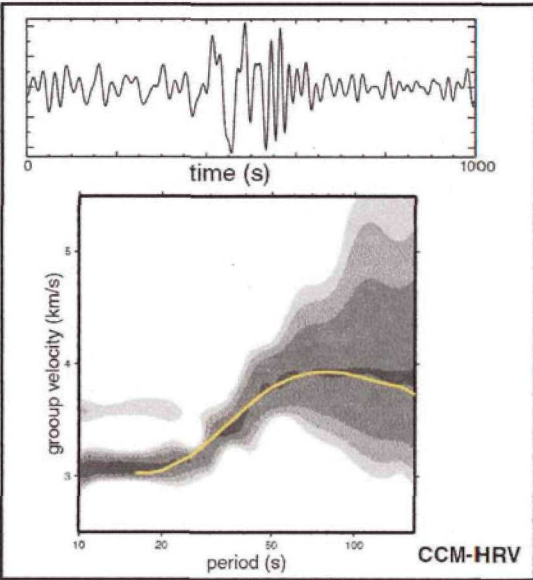
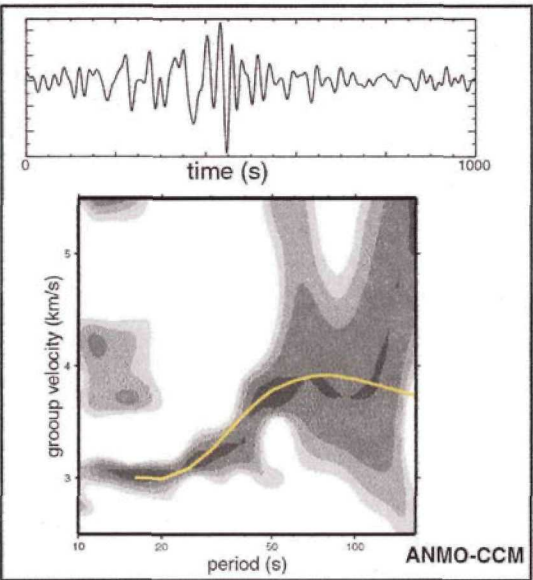
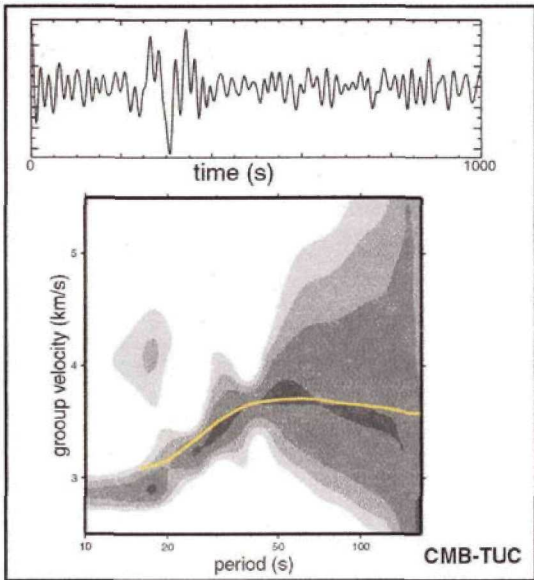

Cross-correlation from ambient seismic noise in North-Western Pacific

broadband cross-correlation
computed from 30 days of
continuous vertical
component records

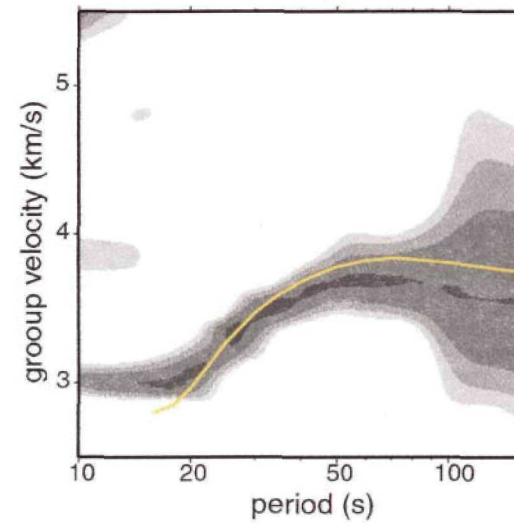
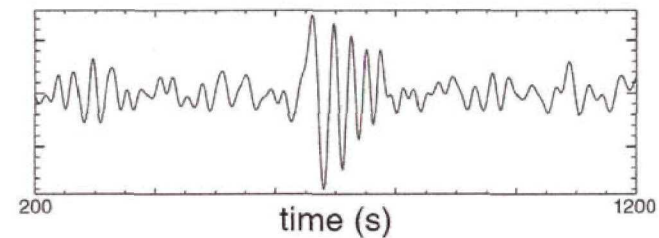
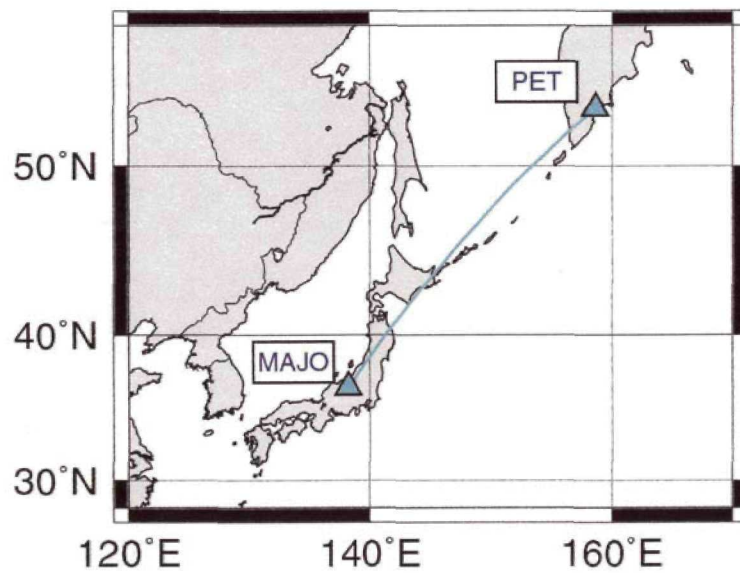

Cross-correlation from ambient seismic noise in North-Western Pacific

broadband cross-correlation
computed from 30 days of
continuous vertical
component records

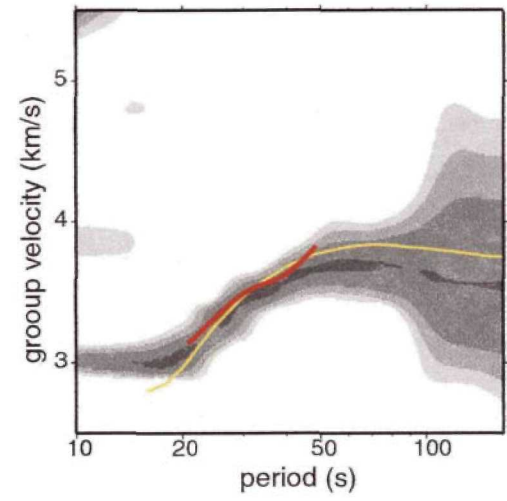
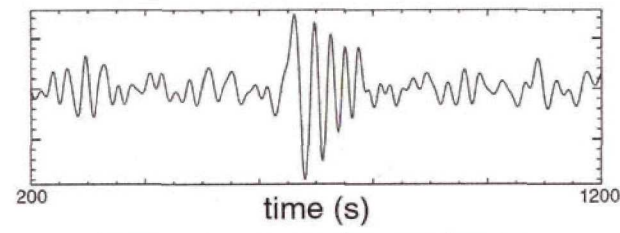
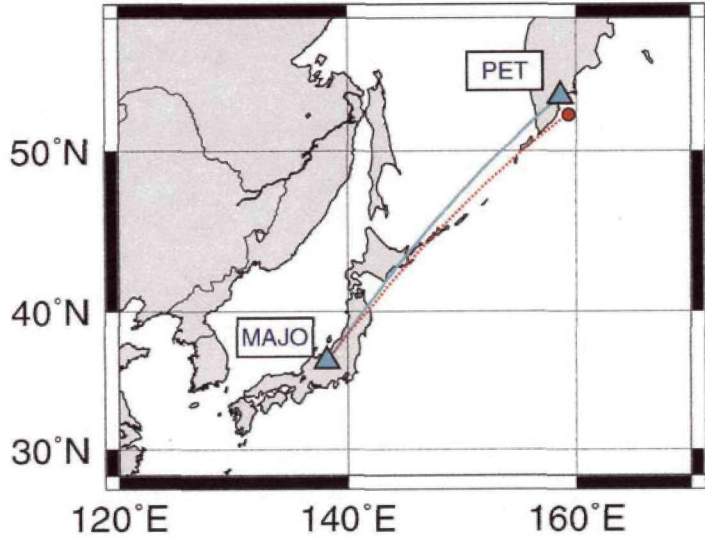

Cross-correlations from ambient seismic noise in California

cross-correlations of vertical component continuous records (1996/02/11-1996/03/10)
0.03-0.2 Hz

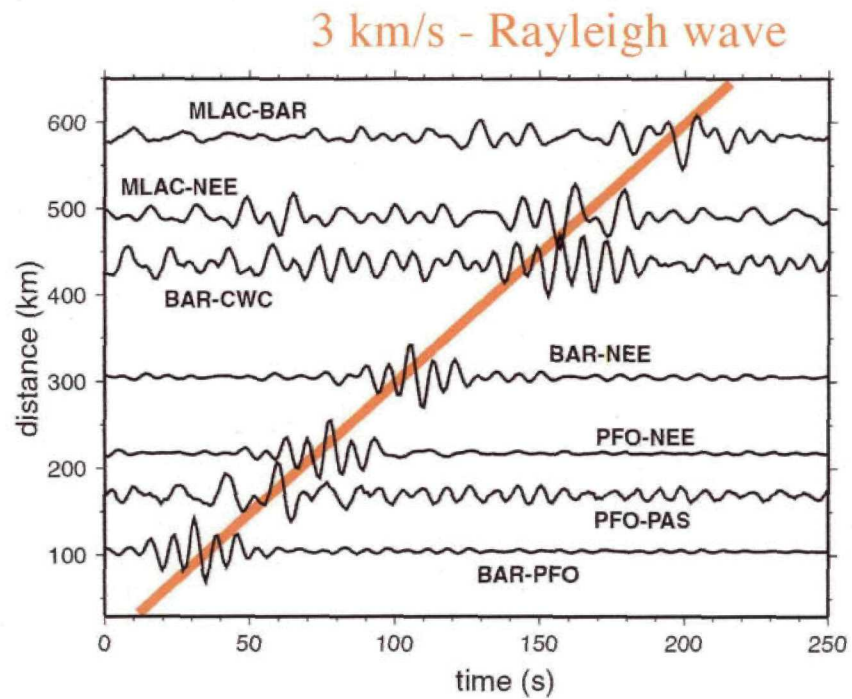
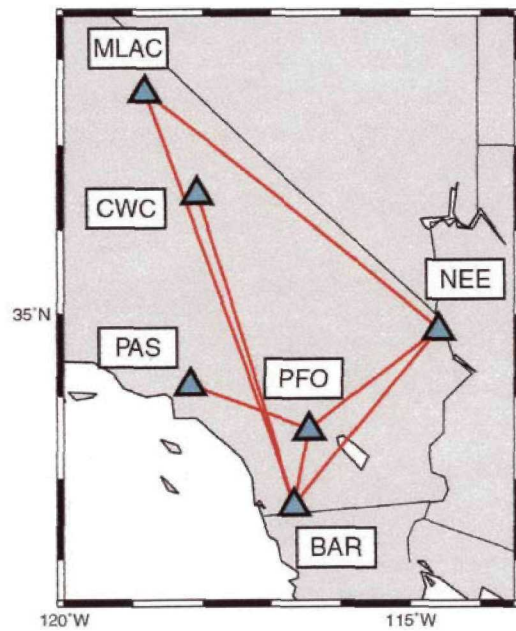

PHL - MLAC 290 km

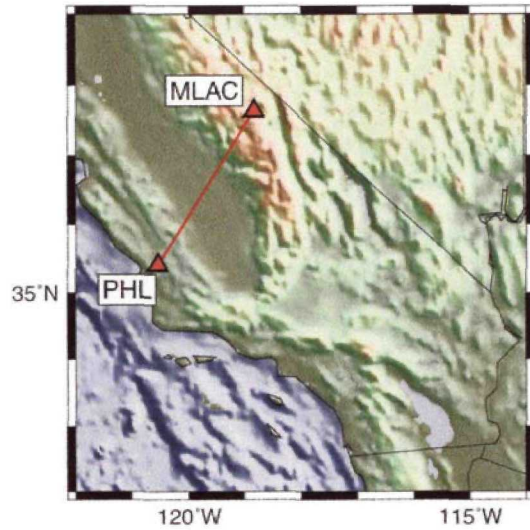

correlations computed over four different three-week periods

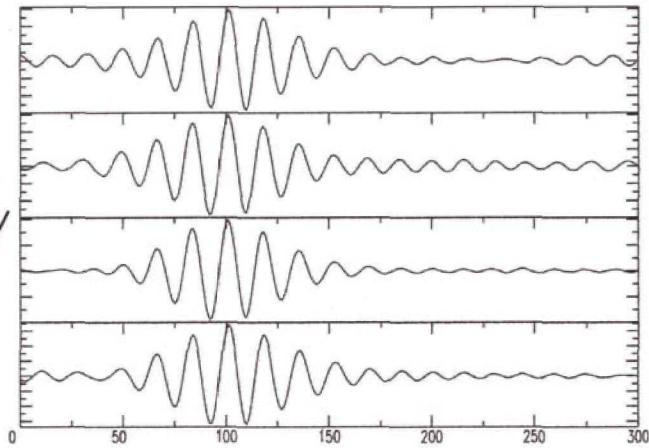

band-passed
15 - 30 s

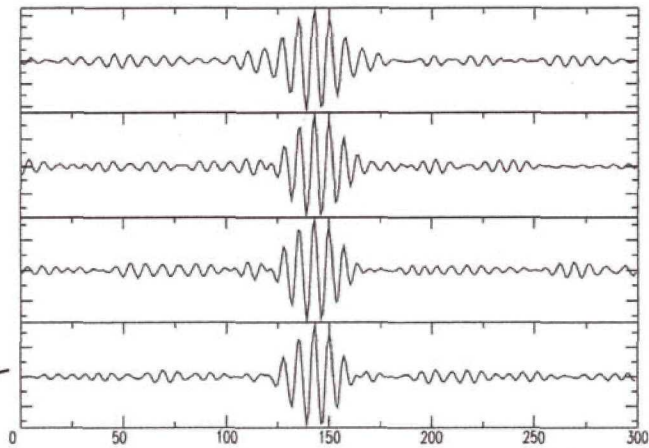
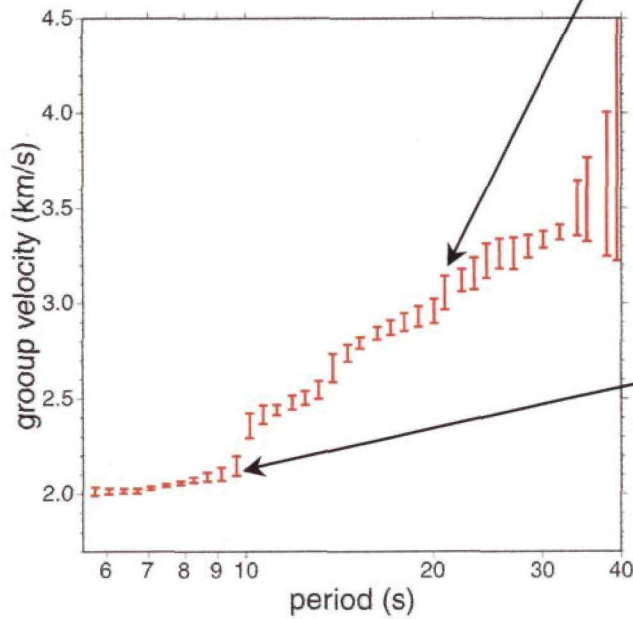

band-passed
5 - 10 s

repetitive measurements provide uncertainty estimations

PHL - MLAC 290 km

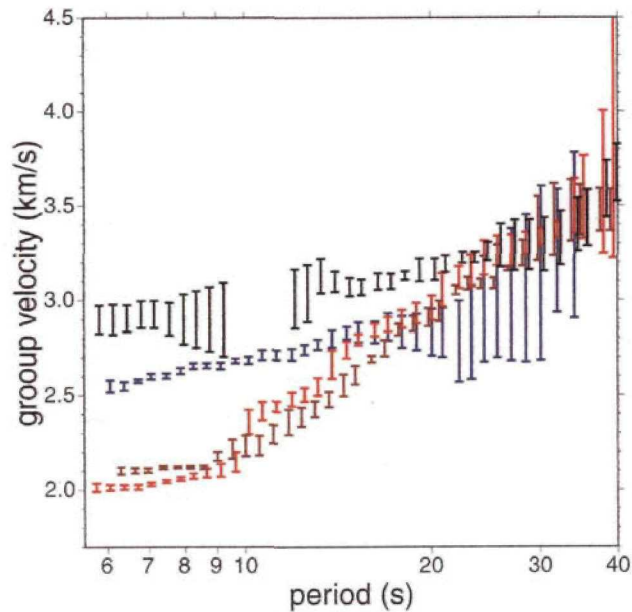
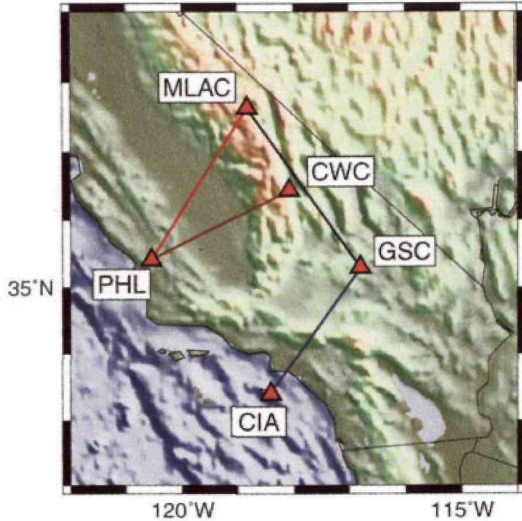

correlations computed over four different three-week periods

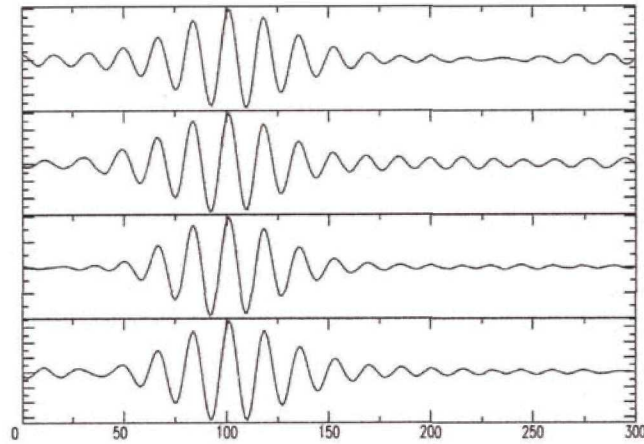

band-passed
15 - 30 s

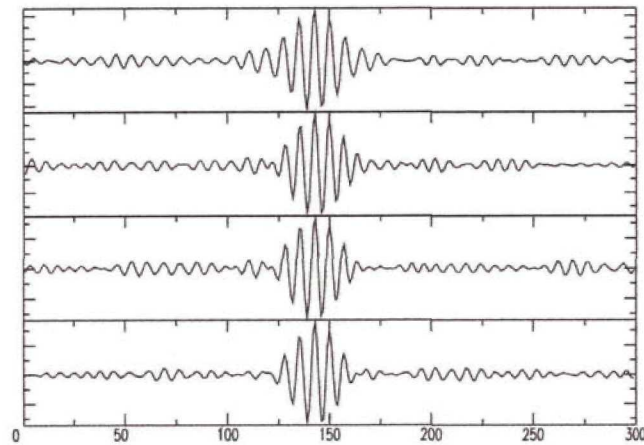

band-passed
5 - 10 s

repetitive measurements provide
uncertainty estimations

Canada

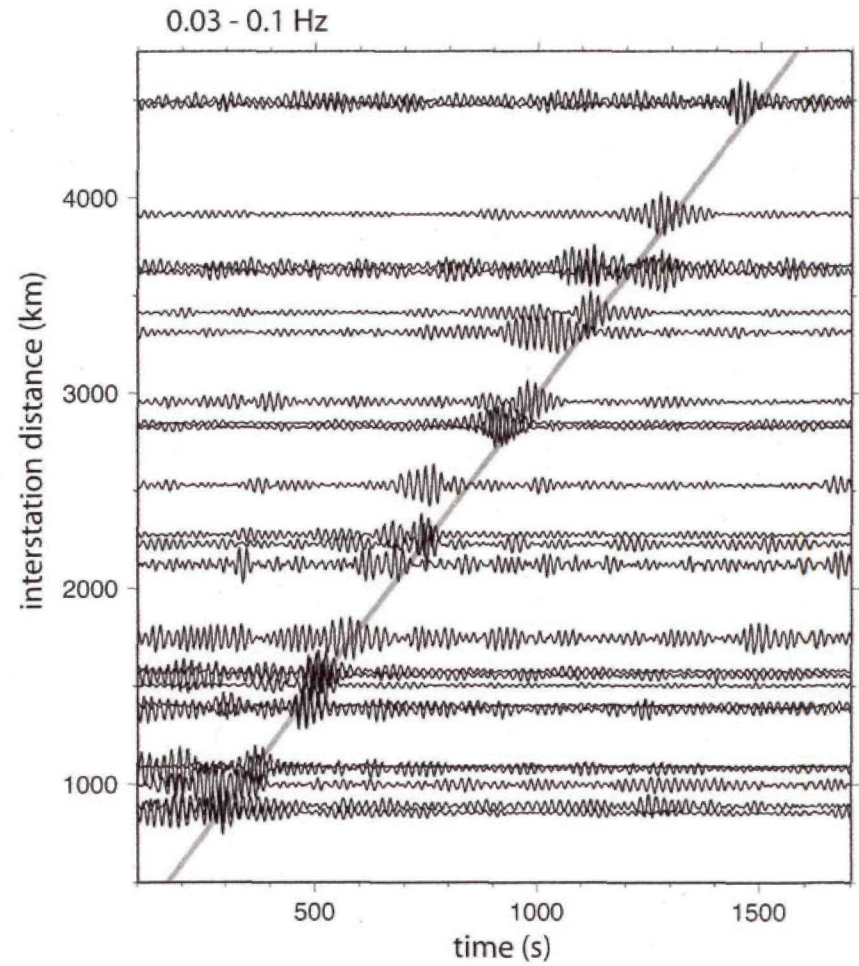
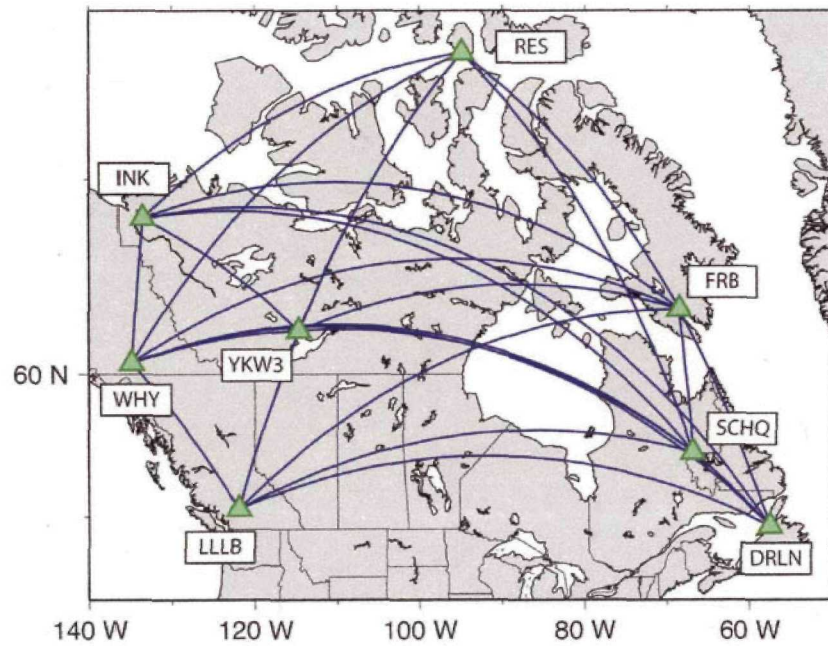

Canada

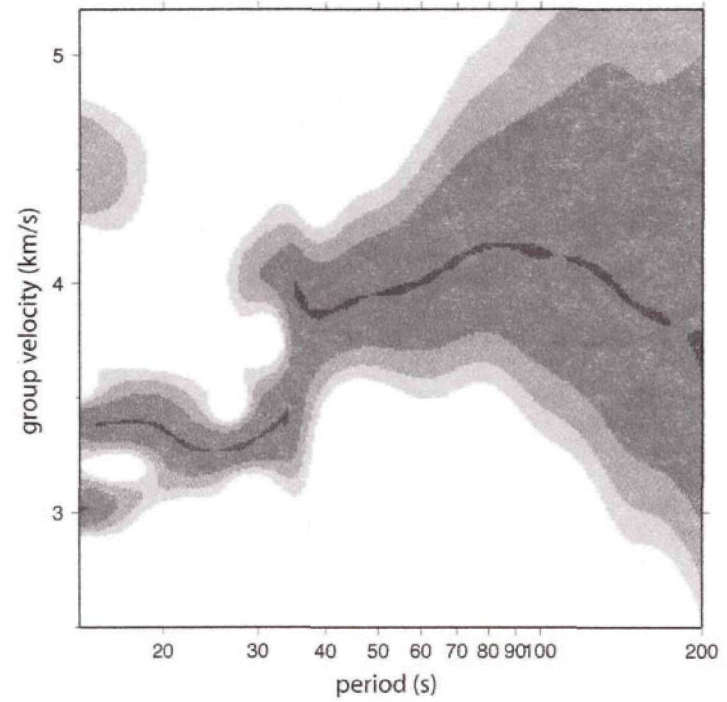
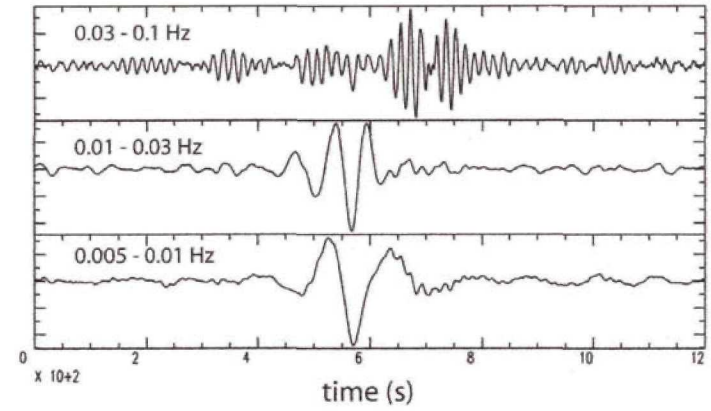
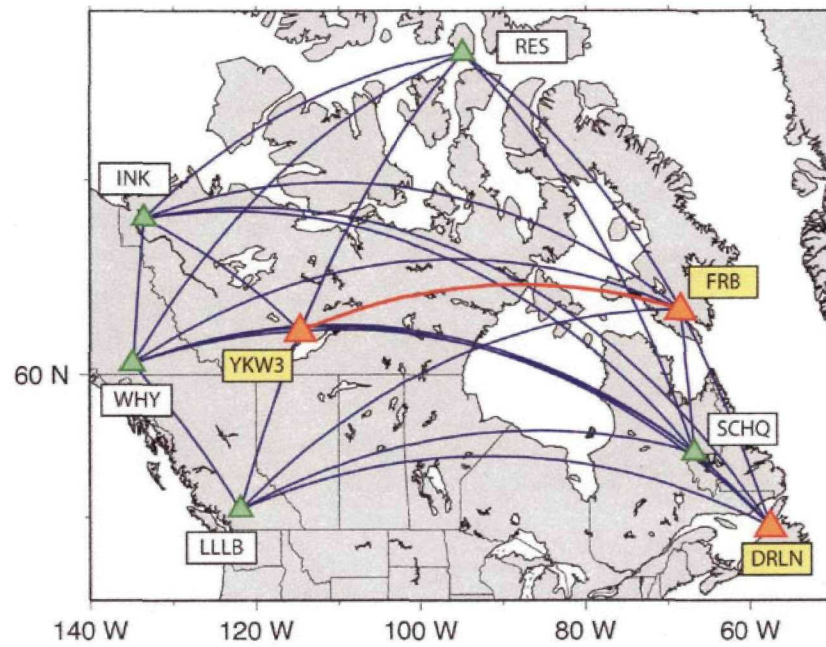

Reference List

<http://ciei.colorado.edu/ritzwoller>

- **Surface wave seismology:**
 - Kennett, B.L.N, *The Seismic Wavefield*, Cambridge University Press, 2001.
 - Stein, S. and M. Wysession, *An Introduction to Seismology, Earthquakes, and Earth Structure*, Blackwell Science, 2002.
- **Surface wave tomography (Diffraction and Dispersion Maps)**
 - Snieder, R. and B. Romanowicz, A new formalism for the effect of lateral heterogeneity on normal modes and surface waves, *Geophys.J. Roy. Astron. Soc.*, 92, 207-222, 1988.
 - Barmin, M.P., M.H.Ritzwoller, and A.L. Levshin, A fast and reliable method for surface wave tomography, *Pure & Appl. Geophys.*, 158(8), 1351-1375, 2001.
 - Ritzwoller, M.H., N.M. Shapiro, M.P. Barmin, and A.L. Levshin, Global surface wave diffraction tomography, *J. Geophys. Res.*, 107(B12), 2335, 2002.
- **Monte-Carlo inversion for a 3-D Vs model from surface waves:**
 - Shapiro, N.M. and M.H. Ritzwoller, Monte Carlo inversion for a global shear velocity model of the crust and upper mantle, *Geophys. J. Int.*, 151, 88-105, 2002.
- **Imposing physical constraints in temperature space:**
 - Turcotte, D.L., G. Schubert, *Geodynamics*, Cambridge University Press, 2001.
 - Shapiro, N.M. and M.H. Ritzwoller, Thermodynamics constraints on seismic inversions, *Geophys. J. Int.*, 157, 1175-1188, 2004.
 - Shapiro, N.M., M.H. Ritzwoller, J.-C. Mareschal, and J. Jaupart, Lithospheric structure of the Canadian Shield inferred from inversion of surface wave dispersion with thermodynamic a priori constraints, *Geol. Soc. Lond. Spec. Publ., Geological Prior Information*, ed. R. Wood and A. Curtis, in press, 2004.
 - Ritzwoller, M.H., N.M. Shapiro, and S. Zhong, Cooling history of the Pacific lithosphere, *Earth Planet. Sci. Letts.*, 226, 69-84, 2004.

Reference List (cont.)

- **Measurements on the random wavefield**
 - Campillo, M. and A. Paul, Long-range correlations in the diffuse seismic coda, *Science*, 299, 547-549, 2003.
 - Shapiro, N.M. and M.Campillo, Emergence of broadband Rayleigh waves from correlations of the ambient seismic noise, *Geophys. Res. Lett.*, 31, L07614, doi:10.1029/2004GL019491, 2004.