

H4.SMR/1586-6

**"7th Workshop on Three-Dimensional Modelling
of Seismic Waves Generation and their Propagation"**

25 October - 5 November 2004

**Introduction to the Theory of
Seismic Wave Propagation**

T. Yanovskaya

**St. Petersburg State University
Institute of Physics
St. Petersburg, Russia**

Introduction to the theory of seismic wave propagation

Contents

1. Introduction.....	1
2. Equation of motion for solid elastic media.....	2
2.1. <i>Homogeneous isotropic elastic medium. P and S waves</i>	3
2.2. <i>Plane waves</i>	3
2.3. <i>Inhomogeneous plane waves</i>	5
2.4. <i>Energy flux</i>	8
2.5. <i>Spherical waves</i>	10
2.6. <i>Cylindrical waves</i>	13
2.7. <i>Anisotropic medium</i>	14
3. Propagation of elastic waves in media with boundaries.....	17
3.1. <i>Boundary conditions</i>	17
3.2. <i>Incidence of a plane wave to a plane boundary</i>	18
3.3. <i>Head waves</i>	23
3.4. <i>Rayleigh waves</i>	24
3.5. <i>Love waves</i>	25
4. Waves in anelastic media.....	27
4.1. <i>Constitutive equations</i>	27
4.2. <i>Propagation of harmonic waves</i>	30
5. Excitation of seismic waves.....	33
5.1. <i>Body forces</i>	33
5.2. <i>Boundary conditions; representation theorem</i>	33
5.3. <i>Green function for isotropic homogeneous medium</i>	35
5.4. <i>Application of the representation theorem to analysis of diffracted waves</i>	35

1. Introduction

Wave motion is one of the well-known scientific concepts. Behavior of the waves on the water surface, as well as propagation of acoustic or light waves are known from everyday experience. However, it is not easy to define *the wave*. In general we can say that it is a form of propagation of a disturbance of some physical field. We know seismic, electromagnetic, acoustic, gravitational waves. Though, there is no exact general definition of the *waves*, because of a variety of their characteristic features in different cases. For example, we may generally define the wave as a disturbance (signal), which propagates in a space with a certain velocity, but a form of the signal, as well as its velocity may vary. However, this definition involves propagation of heat (disturbance of temperature), but it is well known that the heat is propagated in another way – not by a wave. Therefore it is preferable to proceed from an intuitive notion on a wave as on a signal propagating from one to another part of a medium with a certain finite velocity. This signal may be distorted, may change its intensity and velocity, but should remain distinguishable. A perturbation arising in a part of the medium causes returning forces preventing this perturbation, and the forces are of such kind that they lead to appearance of similar (in general not exactly the same) perturbation in neighboring points.

Seismic waves arise in solid media due to elastic forces. A main peculiarity of seismic waves is that there are at least two types of waves (in anisotropic media - three types), with different velocities and different polarization. This fact is due to existence of at least two different elastic modules: in isotropic media - compressible and shear modules. Therefore returning forces are different for different types of deformation.

A nature of the wave may be explained by consideration of a compressional wave in a thin rod. The rod may be represented as a set of interacting elements. If one element is displaced, a force appears between this one and neighboring elements which is proportional to a relative variation of a distance between them. We can imagine that the elements are connected by elastic springs, and the force is due to compression or tension of the springs.

Let a force due to deformation of the spring be

$$K \frac{\Delta u}{\Delta x}$$

Motion of the i -th element of mass m submits to the Newton's law:

$$m\ddot{u}_i = K \frac{u_{i+1} - u_i}{\Delta x} - K \frac{u_i - u_{i-1}}{\Delta x}$$

In continuous case, when $\Delta x \rightarrow 0$, and $m = \rho \Delta x$, $u = u(x, t)$, we obtain

$$\rho \ddot{u} = K \frac{\partial^2 u}{\partial x^2} \quad (1)$$

This is the simplest one-dimensional wave equation. Its solution is as follows:

$$u = f\left(t - \frac{x}{c}\right) + g\left(t + \frac{x}{c}\right), \quad c = \sqrt{\frac{K}{\rho}},$$

where $f(\xi)$ and $g(\xi)$ are arbitrary functions, and c is regarded as velocity of the wave propagation.

If the masses deviate from the equilibrium in perpendicular direction (shear), it would be the same, but the module K is different (it is less than compression module), and the velocity of *shear wave* propagation is less than for the compressional wave.

In continuum (2D or 3D) there are both types of deformation (compression and shear), therefore two types of waves may propagate.

2. Equation of motion for solid elastic media

Consider an element Ω of elastic medium bounded by a surface S .

Equation of motion of this element may be written as follows:

$$\iiint_{\Omega} \rho \frac{d^2 \mathbf{u}}{dt^2} d\Omega = \iint_S \mathbf{T}_n dS + \iiint_{\Omega} \mathbf{F}(\mathbf{x}) d\Omega \quad (1)$$

where \mathbf{F} is body force density, \mathbf{T}_n is stress applied to the boundary.

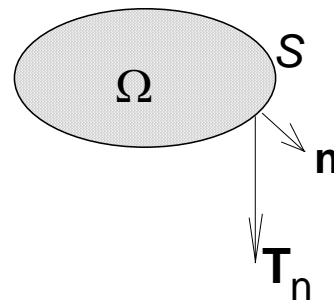

Applying Gauss formula to the surface integral, and taking into account that the stress tensor is symmetric, we finally obtain that

$$\rho \frac{\partial^2 \mathbf{u}}{\partial t^2} = \nabla \mathbb{T} + \mathbf{F} \quad (2)$$

or

$$\rho \frac{\partial^2 \mathbf{u}}{\partial t^2} = \frac{\partial \bar{\tau}_x}{\partial x} + \frac{\partial \bar{\tau}_y}{\partial y} + \frac{\partial \bar{\tau}_z}{\partial z} + \mathbf{F} \quad (3)$$

where \mathbb{T} is stress tensor, or a matrix formed by vector-rows $\bar{\tau}_x, \bar{\tau}_y, \bar{\tau}_z$:

$$\mathbb{T} = \begin{pmatrix} \bar{\tau}_x \\ \bar{\tau}_y \\ \bar{\tau}_z \end{pmatrix}$$

Eqs. (2,3) are valid for all types of media: isotropic, anisotropic, inhomogeneous, anelastic, which differ by the relationship between stress and strain. Below we shall consider some particular cases.

2.1. Homogeneous isotropic medium

In homogeneous isotropic medium the relationship between stress and strain, which in turn is related with spatial derivatives of displacement, is following:

$$\tau_{ij} = \lambda \operatorname{div} \mathbf{u} \delta_{ij} + \mu \left(\frac{\partial u_i}{\partial x_j} + \frac{\partial u_j}{\partial x_i} \right) \quad (4)$$

Substituting (4) to (2) (here we neglect the body forces) we obtain

$$(\lambda + 2\mu) \nabla \operatorname{div} \mathbf{u} - \mu \operatorname{rot} \operatorname{rot} \mathbf{u} = \rho \frac{\partial^2 \mathbf{u}}{\partial t^2} \quad (5)$$

The simplest approach to solve this equation (which is valid only for inhomogeneous medium!) is to represent the unknown vector function in terms of scalar and vector potentials:

$$\mathbf{u} = \nabla \varphi + \operatorname{rot} \boldsymbol{\psi}$$

Substituting this representation to (5) we obtain two independent equations for the potentials:

$$\Delta \varphi = \frac{\rho}{\lambda + 2\mu} \frac{\partial^2 \varphi}{\partial t^2} = \frac{1}{a^2} \frac{\partial^2 \varphi}{\partial t^2} \quad (6a)$$

$$\Delta \boldsymbol{\psi} = \frac{\rho}{\mu} \frac{\partial^2 \boldsymbol{\psi}}{\partial t^2} = \frac{1}{b^2} \frac{\partial^2 \boldsymbol{\psi}}{\partial t^2} \quad (6b)$$

These are the *wave equations* (scalar and vector): they describe propagation of the waves with two different velocities a and b . The scalar potential determines the *longitudinal (compressional)*, or P-wave, vector potential determines the *share*, or S-wave.

To solve these equations we should know the *initial conditions*, i.e. the functions $\varphi(\mathbf{x})$ and $\boldsymbol{\psi}(\mathbf{x})$ at $t=0$.

It is clear that the solutions of (6) are additive, i.e. if φ_1 and φ_2 are two different solutions of (6a), then $\varphi_1 + \varphi_2$ will also be a solution of this equation. It means that that by superposition of different (elementary) solutions we can construct the solution, which would fit the given initial conditions. The simplest elementary solutions are the *plane waves*.

2.2. Plane waves

At first we shall consider the scalar wave equation

$$\Delta u = \frac{1}{c^2} \frac{\partial^2 u}{\partial t^2} \quad (7)$$

$$u = u(x_1, x_2, x_3, t)$$

A solution of (7) may be represented in the following general form:

$$u(\mathbf{x}, t) = f(t - (\mathbf{k}, \mathbf{x})) + g(t + (\mathbf{k}, \mathbf{x})) \quad (8)$$

where $f(\xi)$ and $g(\xi)$ are arbitrary functions, and $|\mathbf{k}|^2 = \frac{1}{c^2}$. So the two terms in the right-hand side of (8) describe the waves propagating in opposite directions with the velocity c . It is clear that at any moment the solution at the planes $(\mathbf{k}, \mathbf{x}) = \text{const}$ is one and the same.

For simplicity we shall represent the solution of (6a),(6b) by one term in (8):

$$\begin{aligned}\varphi(\mathbf{x}, t) &= f(t - (\mathbf{k}_p, \mathbf{x})) & |\mathbf{k}_p| &= \frac{1}{a} \\ \psi(\mathbf{x}, t) &= \mathbf{n}F(t - (\mathbf{k}_s, \mathbf{x})) & |\mathbf{k}_s| &= \frac{1}{b}\end{aligned}$$

Then

$$\mathbf{u} = \mathbf{u}_p + \mathbf{u}_s$$

where

$$\begin{aligned}\mathbf{u}_p &= \nabla \varphi = -\mathbf{k}f'(t - (\mathbf{k}, \mathbf{x})) \\ \mathbf{u}_s &= \text{rot}\psi = (\mathbf{n} \times \mathbf{k})F'(t - (\mathbf{k}, \mathbf{x}))\end{aligned}\quad (9)$$

The motion in P-wave is directed along the direction of propagation \mathbf{k} , whereas in S-wave it is orthogonal to \mathbf{k} .

It is clear that in both cases (P and S waves) the displacement may be represented in the form

$$\mathbf{u} = \mathbf{l}\Phi\left(t - \frac{(\mathbf{n}, \mathbf{x})}{c}\right)\quad (10)$$

where \mathbf{n} and \mathbf{l} are unit vectors, and c is a velocity. Using the concept of plane waves we can show that c may be equal a or b , and in case $c=a$ polarization vector $\mathbf{l}=\mathbf{n}$, and in case of $c=b$ \mathbf{l} is orthogonal to \mathbf{n} .

Substituting (10) to (5) we obtain

$$[(\lambda + \mu)\mathbf{n}(\mathbf{l}, \mathbf{n}) + \mu\mathbf{l}]\Phi''(t - (\mathbf{n}, \mathbf{x})/c) = \rho c^2 \mathbf{l}\Phi''(t - (\mathbf{n}, \mathbf{x})/c)$$

or

$$(\lambda + \mu)\mathbf{n}(\mathbf{l}, \mathbf{n}) = (\rho c^2 - \mu)\mathbf{l}$$

Define $\theta = \frac{\rho c^2 - \mu}{\lambda + \mu}$, then

$$\mathbf{n}(\mathbf{l}, \mathbf{n}) = \theta \mathbf{l}\quad (11)$$

or $\mathbf{N}\mathbf{l} = \theta \mathbf{l}$, where the matrix $\mathbf{N} = \mathbf{n}\mathbf{n}^T$, so that θ and \mathbf{l} are eigenvalue and eigenvector of the matrix \mathbf{N} correspondingly.

It is easy to show that θ fits the equation

$$\theta^3 - \theta^2 = 0$$

which has three roots

$$\theta_1 = 1, \quad \theta_2 = \theta_3 = 0$$

Otherwise

$$c_1 = \sqrt{\frac{\lambda + 2\mu}{\rho}} = a, \quad c_2 = c_3 = \sqrt{\frac{\mu}{\rho}} = b$$

The eigenvector corresponding to the first root is $\mathbf{l}=\mathbf{n}$, and those corresponding to the other two roots are mutually orthogonal unit vectors, both orthogonal to \mathbf{n} , i.e to the direction of propagation. Thus the first root corresponds to the longitudinal wave, and to other ones – to two share waves propagated with one and the same velocity. As

shown below, in anisotropic medium these two roots are different, so that there are two *quasi-share* waves propagating with different velocities.

2.3. Inhomogeneous plane waves

The concept of plane wave may be extended to complex vectors \mathbf{l} and \mathbf{n} .

A solution of the wave equation (5) in the form (10) assumes \mathbf{n} to be a unit vector, i.e.

$$(\mathbf{n}, \mathbf{n}) = 1 \quad (12)$$

But \mathbf{n} can also be a complex vector, i.e.

$$\mathbf{n} = \mathbf{n}_1 + i\mathbf{n}_2$$

Obviously, the function $\Phi(\xi)$, as a function of a complex variable, should also be complex, as well as the polarization vector \mathbf{l} :

$$\mathbf{l} = \mathbf{l}_1 + i\mathbf{l}_2$$

$$\Phi(x + iy) = f(x, y) + ig(x, y)$$

Since both \mathbf{n} and \mathbf{l} are unit vectors, we have

$$(\mathbf{n}_1, \mathbf{n}_1) - (\mathbf{n}_2, \mathbf{n}_2) + 2i(\mathbf{n}_1, \mathbf{n}_2) = 1$$

$$(\mathbf{n}_1, \mathbf{n}_1) - (\mathbf{n}_2, \mathbf{n}_2) = 1$$

$$(\mathbf{n}_1, \mathbf{n}_2) = 0$$

$$(\mathbf{l}_1, \mathbf{l}_1) - (\mathbf{l}_2, \mathbf{l}_2) = 1$$

$$(\mathbf{l}_1, \mathbf{l}_2) = 0$$

As usual, since the displacement \mathbf{u} is real, we take only the real part of the complex solution:

$$\mathbf{u}(\mathbf{x}, t) = \mathbf{l}_1 f(t - (\mathbf{x}, \mathbf{n}_1)/c, -(\mathbf{x}, \mathbf{n}_2)/c) - \mathbf{l}_2 g(t - (\mathbf{x}, \mathbf{n}_1)/c, -(\mathbf{x}, \mathbf{n}_2)/c) \quad (13)$$

This formula describes *inhomogeneous plane wave*. The motion in the inhomogeneous wave has the following meaning. Temporal behaviour of displacement is one and the same along straight lines determining by intersection of the planes $(\mathbf{x}, \mathbf{n}_1) = \text{const}$ and $(\mathbf{x}, \mathbf{n}_2) = \text{const}$. Direction of the wave propagation coincides with the vector \mathbf{n}_1 , the wave propagates along this direction with the velocity $V = \frac{c}{|\mathbf{n}_1|}$. Since $|\mathbf{n}_1| = \sqrt{1 + |\mathbf{n}_2|^2} > 1$, velocity of the inhomogeneous wave is

always less than c (a or b). The wave form and the wave amplitude are changing in direction of the vector \mathbf{n}_2 . Components of the displacement along vectors \mathbf{l}_1 and \mathbf{l}_2 are changing differently, accordingly to the different functions f and g .

The vectors \mathbf{l}_1 and \mathbf{l}_2 in compressional wave coincide with the vectors \mathbf{n}_1 and \mathbf{n}_2 . In shear wave the vectors \mathbf{l}_1 and \mathbf{l}_2 satisfy the relations

$$(\mathbf{l}_1, \mathbf{n}_1) - (\mathbf{l}_2, \mathbf{n}_2) = 0 \quad (14)$$

$$(\mathbf{l}_1, \mathbf{n}_2) + (\mathbf{l}_2, \mathbf{n}_1) = 0$$

Orientation of the vectors \mathbf{n}_1 , \mathbf{n}_2 , \mathbf{l}_1 , \mathbf{l}_2 are shown below.

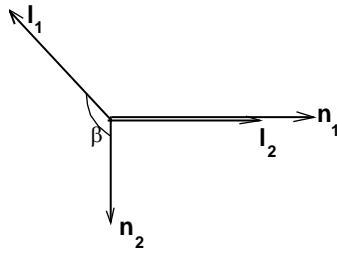

It follows from (14) that

$$\cos \beta = -\frac{(\mathbf{n}_1, \mathbf{l}_2)}{|\mathbf{n}_2| |\mathbf{l}_1|}$$

If $\beta = \pi$, we have SV-wave, and in case $\beta = \pi/2$ the wave is SH. It is clear that for SH-wave $\mathbf{l}_2 = 0$, and only in this case polarization is linear.

If the function $\Phi(z)$ is analytical, then, according to the Cauchy-Riemann relationship for real and imaginary parts of an analytical function of complex variable

$$\frac{\partial f}{\partial x} = \frac{\partial g}{\partial y}, \quad \frac{\partial f}{\partial y} = -\frac{\partial g}{\partial x}$$

If the motion is harmonic oscillation with frequency ω , i.e. if

$$\Phi(z) = A \exp(i\omega z) = A \exp(i\omega x - \omega y), \text{ then}$$

$$f(x, y) = A e^{-\omega y} \cos \omega x$$

$$g(x, y) = A e^{-\omega y} \sin \omega x$$

Particle motion in harmonic inhomogeneous waves is elliptic for P and SV waves, and linear for SH waves (see fig. below)

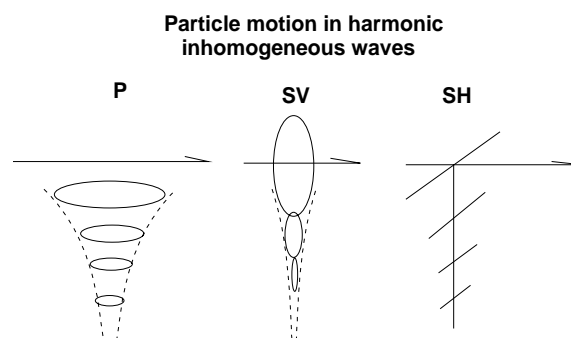

In general case the functions $f(x, y)$, $g(x, y)$ may be represented as a superposition of these solutions, i.e.

$$f(x, y) = \int_0^{\infty} A(\omega) e^{-\omega y} \cos \omega x d\omega$$

$$g(x, y) = \int_0^{\infty} A(\omega) e^{-\omega y} \sin \omega x d\omega$$

Since time t enters to x ($x = t - (\mathbf{n}_1, \mathbf{x})/c$), then a shape of signal at a fixed point \mathbf{x} is determined by f and g as functions of x . It is clear that the function g as a function of x (or t) in a given point \mathbf{x} is the Hilbert transform of f .

Remind that this theory is true if $\Phi(\xi)$ (and consequently $f(x, y)$ as a function of t) are analytical functions. However, in practice, we deal with non-analytical signals, which are equal to zero up to some moment. Nevertheless, usually the theory of inhomogeneous waves is extended to this case, and $g(t)$ is assumed to be the Hilbert transform of non-analytical $f(t)$. This leads to a paradox – the signal in inhomogeneous wave arrives earlier than should be expected according to the causality principle. Examples of such signals (bold lines) and corresponding Hilbert transforms (dashed lines) are shown below. Nevertheless it is possible to use for practical problems, because the earlier disturbance is not significant.

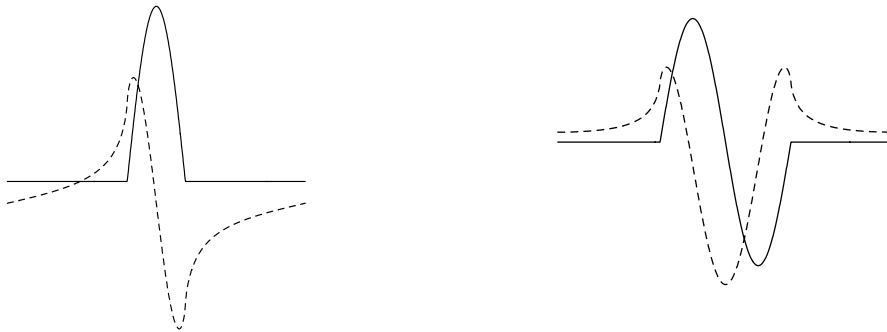

The functions f and g are not finite in the infinite space due to the exponential term $e^{-\omega y}$. Therefore they may be used to represent solutions of the wave motion either in a finite volume, or in case of sources.

Any wave field may be represented by superposition of plane waves (both homogeneous and inhomogeneous), which fits the equation of motion (5) and the following boundary conditions:

- radiation condition, requiring the displacement not to increase at the infinity;
- boundary conditions at interfaces in the medium;
- conditions in the points where sources are located.

The 1st and the 3d (and sometimes the 2nd) conditions cannot be satisfied by only homogeneous plane waves. In such cases the inhomogeneous waves should be involved.

2.4. Energy flux

2.4.1. Energy density

Total wave energy is a sum of kinetic and potential energy. The density of kinetic energy is

$$W_k = \frac{1}{2} \rho \left| \frac{\partial \mathbf{u}}{\partial t} \right|^2$$

Potential energy is the energy of elastic deformation. The density of the potential energy is determined as

$$W_p = \frac{1}{2} \sum_{i,j} \tau_{ij} \varepsilon_{ij},$$

where τ_{ij} is stress tensor, and ε_{ij} is strain tensor: $\varepsilon_{ij} = \frac{1}{2} \left(\frac{\partial u_i}{\partial x_j} + \frac{\partial u_j}{\partial x_i} \right)$. For

homogeneous isotropic medium

$$W_p = \frac{1}{2} \lambda (\text{div} \mathbf{u})^2 + \mu \sum_{ij} \varepsilon_{ij}^2 \quad (15)$$

2.4.2. Energy density in plane waves

For plane wave $\mathbf{u}(\mathbf{x}, t) = \mathbf{l} \Phi(t - (\mathbf{x}, \mathbf{n})/c)$ the density of kinetic energy is expressed as

$$W_k = \frac{\rho}{2} [\Phi']^2 \quad \text{- for homogeneous wave}$$

$$W_k = \frac{\rho}{2} |\mathbf{l}_1 f' - \mathbf{l}_2 g'|^2 = \frac{\rho}{2} (|\mathbf{l}_1|^2 (f')^2 + |\mathbf{l}_2|^2 (g')^2) \quad \text{- for inhomogeneous wave}$$

(here and below f' and g' mean $\frac{\partial f}{\partial t}$ and $\frac{\partial g}{\partial t}$).

The density of potential energy is

$$W_p = \frac{1}{2} \left\{ \frac{\lambda + 2\mu}{c^2} [(\mathbf{l}, \mathbf{n}) \Phi']^2 + \frac{\mu}{c^2} [|\mathbf{l} \times \mathbf{n}| \Phi']^2 \right\} = \frac{\rho}{2} [\Phi']^2 = W_k \quad \text{-for homogeneous wave.}$$

For inhomogeneous wave we must replace $\text{div} \mathbf{u}$ and ε_{ij} in (15) by $\Re \text{div} \mathbf{u}$ and $\Re \varepsilon_{ij}$. These expressions are different for P, SV and SH waves:

$$W_p = \frac{\rho}{2} \left\{ (f')^2 + \frac{4\mu |\mathbf{n}_1|^2 |\mathbf{n}_2|^2}{\rho \alpha^2} [(f')^2 + (g')^2] \right\} \quad \text{- for P -wave,}$$

$$W_p = \frac{\rho}{2} \left\{ (f')^2 + 4 |\mathbf{n}_1|^2 |\mathbf{n}_2|^2 [(f')^2 + (g')^2] \right\} \quad \text{for SV-wave,}$$

$$W_p = \frac{\rho}{2} \left\{ (f')^2 + |\mathbf{n}_2|^2 [(f')^2 + (g')^2] \right\} \quad \text{-for SH-wave.}$$

Taking into account that for P and SV waves $|\mathbf{n}_1| = |\mathbf{l}_1|$, and $|\mathbf{n}_2| = |\mathbf{l}_2|$, as well as $\mathbf{l}_2=0$ for SH-wave, we may write all these expressions in common form:

$$W_p = \frac{\rho}{2} \left\{ (f')^2 + |\mathbf{n}_2|^2 [(f')^2 + (g')^2] \right\} + \frac{2\mu |\mathbf{n}_1|^2 |\mathbf{l}_2|^2}{c^2} [(f')^2 + (g')^2] \quad (16)$$

The first term ($\frac{\rho}{2}(f')^2$) is similar to that for homogeneous wave, the second one describes the energy of elastic deformation due to amplitude variation in the direction perpendicular to the wave propagation, and the third one includes the part of energy due to non-linearity of polarization.

It should be noted that the total energy density is not constant as in case of oscillation. However, it can be explained easily: the energy is transported within the medium, and the energy conservation law is justified for the whole volume.

In case of harmonic wave $\mathbf{u} = \mathbf{l} \exp[i\omega(t - (\mathbf{x}, \mathbf{n})/c)]$ the total energy density is

$$W = \rho\omega^2 \sin^2[\omega(t - (\mathbf{x}, \mathbf{n})/c)] \text{ for homogeneous wave,}$$

and

$$W = \rho\omega^2 \exp\left(\frac{2\omega(\mathbf{x}, \mathbf{n}_2)}{c}\right) \left(\sin^2[\omega(t - (\mathbf{x}, \mathbf{n}_1)/c)] + \frac{|\mathbf{n}_2|^2}{2} + \frac{2\mu |\mathbf{n}_1|^2 |\mathbf{l}_2|^2}{\rho c^2} \right)$$

for inhomogeneous P, SV and SH waves.

So for homogeneous wave the energy oscillates within a half of period from 0 to $\rho\omega^2$, whereas for inhomogeneous wave it never achieves 0. This can be easily explained: if the amplitude does not change along the wave front, then at the moments corresponding to maximum displacement both velocity and strain vanish, whereas this is not so in case of elliptic polarization and variation of the amplitude in the direction perpendicular to the wave propagation.

2.4.3. Vector of the energy flux (Poynting vector)

Here we shall derive the expression for the energy flux in general case.

For simplicity we assume that no external forces act in the medium, then the equation of motion is

$$\nabla \mathbf{T} = \rho \ddot{\mathbf{u}} \quad (17)$$

Multiply (17) by $\dot{\mathbf{u}}$:

$$(\nabla \mathbf{T}, \dot{\mathbf{u}}) = \rho \ddot{\mathbf{u}} \dot{\mathbf{u}} = \frac{1}{2} \frac{\partial (\rho \dot{\mathbf{u}}^2)}{\partial t} = \frac{\partial W_k}{\partial t}$$

$$(\nabla \mathbf{T}, \dot{\mathbf{u}}) = \nabla(\mathbf{T}\dot{\mathbf{u}}) - (\mathbf{T}\nabla, \dot{\mathbf{u}})$$

The last term in the right-hand side is

$$(\mathbf{T}\nabla, \dot{\mathbf{u}}) = \tau_{ik} \dot{\varepsilon}_{ik} = c_{ijkl} \varepsilon_{jl} \dot{\varepsilon}_{ik} = \frac{\partial}{\partial t} \left(\frac{1}{2} c_{ijkl} \varepsilon_{jl} \varepsilon_{ik} \right) = \frac{\partial}{\partial t} \left(\frac{1}{2} \tau_{ik} \varepsilon_{ik} \right) = \frac{\partial W_p}{\partial t}$$

Thus $\frac{\partial W}{\partial t} = \nabla(\mathbf{T}\dot{\mathbf{u}}) = -\nabla \mathbf{p}$ $\mathbf{p} = -\mathbf{T}\dot{\mathbf{u}}$ - Poynting vector

Therefore, if $E = \iiint_{\Omega} W d\Omega$, then

$$\frac{\partial E}{\partial t} = -\iiint_{\Omega} \text{div} \mathbf{p} d\Omega = -\iint_S p_n dS$$

Thus, variation of the energy within a volume Ω is equal (with opposite sign) to a flux of the Poynting vector across its surface.

On the other hand, $\frac{\partial E}{\partial t} = -\iint_s Wc_n dS$ and $\mathbf{p}=W\mathbf{c}$, where \mathbf{c} is group velocity, i.e.

velocity with which the energy transports: in case of homogeneous wave in isotropic medium it is equal to $c\mathbf{n}$, and in case of inhomogeneous wave it is $\frac{c}{|\mathbf{n}_1|} \frac{\mathbf{n}_1}{|\mathbf{n}_1|}$.

The relationship $W\mathbf{c} = -\mathbf{T}\mathbf{u}$ is useful in case of anisotropic media (as will be shown later), because it provides the expression for group velocity, which differs from phase velocity.

2.5. Spherical waves

We consider spherically symmetric solution of scalar wave equation

$$\Delta\varphi = \frac{1}{a^2}\ddot{\varphi}, \quad \varphi = \varphi(R,t)$$

In spherical coordinates

$$\Delta\varphi = \frac{1}{R^2} \frac{\partial}{\partial R} \left(R^2 \frac{\partial \varphi}{\partial R} \right) + \frac{1}{R^2 \sin \theta} \frac{\partial}{\partial \theta} \left(\sin \theta \frac{\partial \varphi}{\partial \theta} \right) + \frac{1}{R^2 \sin^2 \theta} \frac{\partial^2 \varphi}{\partial \phi^2}$$

For spherically symmetric solution

$$\frac{1}{R^2} \frac{\partial}{\partial R} \left(R^2 \frac{\partial \varphi}{\partial R} \right) = \frac{1}{a^2} \frac{\partial^2 \varphi}{\partial t^2}, \quad (18)$$

or

$$\frac{\partial^2 \varphi}{\partial R^2} + \frac{2}{R} \frac{\partial \varphi}{\partial R} = \frac{1}{a^2} \frac{\partial^2 \varphi}{\partial t^2},$$

The latter may be represented in the form

$$\frac{\partial^2}{\partial R^2} (R\varphi) = \frac{1}{a^2} \frac{\partial^2}{\partial t^2} (R\varphi)$$

A solution for $R\varphi$ is the same as for 1D wave equation, and for the case, when the wave is expanded from the origin ($R=0$)

$$\varphi(R,t) = \frac{F(t - R/a)}{R} \quad (19)$$

It should be noted that (19) represents a solution of (18) everywhere except the point $R=0$. But because the wave propagates from $R=0$, this point may be regarded as a source, where a body force is applied. Therefore to get the solution, which exists everywhere including $R=0$, we must proceed from another equation, notably,

$$\frac{1}{R^2} \frac{\partial}{\partial R} \left(R^2 \frac{\partial \varphi}{\partial R} \right) = \frac{1}{a^2} \frac{\partial^2 \varphi}{\partial t^2} - 4\pi\delta(R)F(t) \quad (20)$$

Then (19) is the solution of (20) valid in the whole space.

It should be noted that a solution in the form of 'pure' spherical wave exists only for compressional waves. For shear wave we cannot have spherical symmetry because this is impossible for vectors tangential to a spherical surface.

Now we shall represent spherical wave as a superposition of plane waves. For this purpose it is necessary at first to represent the function $F(t)$ in a form of the Fourier integral

$$-F(t) = \int_{-\infty}^{\infty} \hat{F}(\omega) \exp(i\omega t) d\omega .$$

It will be sufficient to restrict the analysis by a harmonic wave:

$$\varphi(R, t) = \frac{\exp[i\omega(t - R/a)]}{R}$$

Also we may omit the factor $\exp(i\omega t)$, and consider the part of the solution, which depends only on spatial coordinates:

$$\varphi(R) = \frac{\exp(i\omega R)}{R} \quad (21)$$

(The sign in the exponent also may be assumed opposite).

(21) is a solution of the equation resulting from (20):

$$\Delta\varphi + \frac{\omega^2}{a^2}\varphi = -4\pi\delta(\mathbf{x}) \quad (22)$$

Let us represent the solution in a form of 3D spatial Fourier transform:

$$\varphi(\mathbf{x}) = \frac{1}{8\pi^3} \iiint \Phi(\mathbf{k}) \exp[i(\mathbf{k}, \mathbf{x})] d\mathbf{k} , \quad (23)$$

then, substituting (23) to (22), we obtain the equation for $\Phi(\mathbf{k})$:

$$\Phi(\mathbf{k}) = \frac{4\pi}{k^2 - \frac{\omega^2}{a^2}}$$

where

$$k^2 = (\mathbf{k}, \mathbf{k}) = k_x^2 + k_y^2 + k_z^2 \quad (24)$$

Thus,

$$\frac{\exp(i\omega R/a)}{R} = \frac{1}{2\pi^2} \iiint_{-\infty}^{\infty} \frac{\exp[i(\mathbf{k}, \mathbf{x})]}{k^2 - \frac{\omega^2}{a^2}} dk_x dk_y dk_z$$

But the because of (24) the variables k_x, k_y, k_z are not independent. Therefore we can integrate over one of the components of the wave vector, e.g. over k_z . The integration is performed by the use of the theory of residuals, and finally we obtain

$$\frac{\exp(i\omega R/a)}{R} = \frac{1}{2\pi} \iint \frac{\exp[i(k_x x + k_y y) - \gamma|z|]}{\gamma} dk_x dk_y \quad (25)$$

where

$$\gamma = \left(k_x^2 + k_y^2 - \frac{\omega^2}{a^2} \right)^{1/2}$$

and the sign at γ is chosen so that $\text{Re } \gamma > 0$.

(25) is the Weyl integral, which represents spherical wave as superposition of plane waves. Since $-\infty < k_x < \infty, -\infty < k_y < \infty$, the integrand contains not only homogeneous, but also inhomogeneous plane waves.

The integral (25) may be transformed to the Sommerfeld integral, which represents spherical wave as a superposition of cylindrical waves. Let us replace the variables:

$$x = r \cos \eta \quad k_x = k \cos \varphi$$

$$y = r \sin \eta \quad k_y = k \sin \varphi$$

Then

$$\frac{\exp(i\omega R/a)}{R} = \frac{1}{2\pi} \int_0^\infty \int_0^{2\pi} \frac{\exp[ikr \cos(\varphi - \eta) - \gamma|z|]}{\gamma} k dk d\varphi$$

Taking into account that $\frac{1}{2\pi} \int_0^{2\pi} \exp[ikr \cos(\varphi - \eta)] d\varphi = J_0(kr)$

we obtain

$$\frac{\exp(i\omega R/a)}{R} = \int_0^\infty \frac{J_0(kr) \exp(-\gamma|z|)}{\gamma} k dk$$

In case of $\exp(-i\omega R/a)$ it is necessary to take γ^* (complex conjugate) instead of γ in the right-hand side.

This relationship can be extended to a case of non-analytical signals with sharp onset. If $F(\omega)$ is Fourier transform of such a signal $f(t)$, then

$$\frac{f(t - R/a)}{R} = \frac{\int_{-\infty}^\infty F(\omega) \exp[i\omega(t - R/a)]}{R} = \int_{-\infty}^\infty F(\omega) \exp(i\omega t) \int_0^\infty \frac{J_0(kr) \exp(-\gamma|z|)}{\gamma} k dk$$

How to understand that a wave with discontinuity on the front can be represented as a superposition of the waves including inhomogeneous waves, which arise simultaneously along the whole vertical axis? It is easier to analyze spherical wave as a superposition of cylindrical waves (Sommerfeld integral) rather than of plane waves.

Let us take $r=0$. Then the integral represents the wave field at the z-axis. The integral becomes

$$\int_0^\infty \frac{\exp(-\gamma|z|)}{\gamma} k dk = \int_0^{\omega/a} + \int_{\omega/a}^\infty = \left(\begin{array}{l} \text{homogeneous} \\ \text{waves } (\gamma = i\xi) \end{array} \right) + \left(\begin{array}{l} \text{inhomogeneous} \\ \text{waves } (\gamma \text{ is real}) \end{array} \right)$$

Now we shall show that contribution of the inhomogeneous waves is compensated by a part of contribution of homogeneous waves

Contribution of homogeneous waves:

$$\int_0^{\omega/a} \frac{\exp(-i\xi|z|)}{i\xi} k dk = i \int_{\omega/a}^0 \exp(-i\beta|z|) d\beta = \frac{\exp(-i\omega|z|/a)}{|z|} - \frac{1}{|z|}$$

Contribution of inhomogeneous waves:

$$\int_{\omega/a}^\infty \frac{\exp(-\gamma|z|)}{\gamma} k dk = \int_0^\infty \exp(-\zeta|z|) d\zeta = \frac{1}{|z|}$$

Thus the total contribution of the inhomogeneous waves is cancelled by a part of the contribution of homogeneous waves.

2.6. Cylindrical waves

If the wave field is symmetric in respect to a straight line (z -axis), and the field does not depend on z -coordinate, the wave equation for potentials may be written in cylindrical coordinates as follows:

$$\frac{1}{r} \frac{\partial}{\partial r} \left(r \frac{\partial \varphi}{\partial r} \right) = \frac{1}{c^2} \frac{\partial^2 \varphi}{\partial t^2}, \quad (c = a) \quad \text{for scalar potential,}$$

and similar equations for components of the vector potential with $c=b$.

This case may be regarded as 2D case, i.e. corresponding to the wave propagation in a plane $z=\text{const}$. In contradiction to the 1D case, to which a plane wave can be reduced, and to the 3D case (spherical wave), in 2D case it is impossible to construct a solution in a general form $f(r,t)$, and it is necessary to express a solution as a function of t in the form of Fourier integral, and consequently to solve the equation for the harmonic wave:

$$\frac{1}{r} \frac{\partial}{\partial r} \left(r \frac{\partial \hat{\varphi}}{\partial r} \right) + \frac{\omega^2}{c^2} \hat{\varphi} = 0 \quad (26a)$$

or

$$\frac{\partial^2 \hat{\varphi}}{\partial r^2} + \frac{1}{r} \frac{\partial \hat{\varphi}}{\partial r} + k^2 \hat{\varphi} = 0 \quad (26b)$$

where $k = \omega / c$.

Solution of the eq.(26b) is a combination of the Bessel functions. If the time function is taken in the form $\exp(i\omega t)$, and the wave is expanded from $r=0$, then

$$\hat{\varphi}(r, \omega) = AH_0^{(2)}(kr),$$

and the solution for $\varphi(r, t)$ is following:

$$\varphi(r, t) = \frac{1}{2\pi} \int_{-\infty}^{\infty} A(\omega) H_0^{(2)}(\omega r / c) \exp(i\omega t) d\omega$$

It is clear that, in contradiction to the 1D and 3D cases, the waveform is not remained unchanged in the process of propagation. This peculiarity was noticed by Hadamard in his classic studies of the wave equation: he pointed that the behavior of the solution is different for odd and even numbers of spatial dimension.

At large distances $\left(\frac{\omega r}{c} \gg 1 \right)$ we can use the asymptotic representation for the Hankel function, so that the solution can be written as a wave with preserved form and with the amplitude decaying as $\frac{1}{\sqrt{r}}$:

$$\varphi(r, t) = C \frac{\exp[i\omega(t - r/c)]}{\sqrt{r}}$$

Though it seems that cylindrical waves cannot be excited in reality, they are important in analysis of surface waves and the waves with axial symmetry.

2.6. Anisotropic medium

For anisotropic elastic medium the relationship between stresses and derivatives of displacement is expressed by the Hooke's law in the form:

$$\tau_{ij} = c_{ijkl} \varepsilon_{kl} \quad (27)$$

(summation over repeated subscripts is assumed here and below). In the similar notation we may re-write the equation of motion (2):

$$\frac{\partial \tau_{ij}}{\partial x_j} = \rho \frac{\partial^2 u_i}{\partial t^2} \quad (28)$$

Substitute (27) into (28):

$$\frac{1}{2} c_{ijkl} \frac{\partial}{\partial x_j} \left(\frac{\partial u_k}{\partial x_l} + \frac{\partial u_l}{\partial x_k} \right) = \rho \frac{\partial^2 u_i}{\partial t^2} \quad (29)$$

A solution of this equation also may be represented in a form of plane waves:

$$u_i = l_i \Phi \left(t - \frac{n_q x_q}{c} \right) \quad (30)$$

where n_q are components of the unit vector indicating the direction of propagation, and l_i are components of the polarization (unit) vector. Substitute this to (29):

$$\frac{1}{2} c_{ijkl} (l_k n_j n_l + l_l n_k n_j) = \rho c^2 l_i \quad (31)$$

This is a system of 3 linear equation respectively the components of the polarization vector l_1, l_2, l_3 . Determinant of the system should be equated to 0, so we obtain a cubic equation for c^2 . All three roots of this equations are different (unlike the isotropic case) and depend on \mathbf{n} , i.e. the velocity is different in different directions. The components of the vector \mathbf{l} are not related to \mathbf{n} as was in isotropic case.

In this case we have no pure 'longitudinal' and 'shear' waves: in so-called 'quasi-longitudinal' wave the polarization vector \mathbf{l} does not coincide with \mathbf{n} , and in two 'quasi-shear' waves they are not orthogonal to \mathbf{n} .

Example: Transersly isotropic medium

Let z -axis is the axis of symmetry. Then

$$\tau_{xx} = A\varepsilon_{xx} + (A - 2N)\varepsilon_{yy} + F\varepsilon_{zz}$$

$$\tau_{yy} = A\varepsilon_{yy} + (A - 2N)\varepsilon_{xx} + F\varepsilon_{zz}$$

$$\tau_{zz} = F(\varepsilon_{xx} + \varepsilon_{yy}) + C\varepsilon_{zz}$$

$$\tau_{xy} = N\varepsilon_{xy}$$

$$\tau_{yz} = L\varepsilon_{yz}$$

$$\tau_{zx} = L\varepsilon_{zx}$$

As before, we look for a solution for plane wave in the form

$$\mathbf{u} = \mathbf{l}\Phi\left(t - \frac{(\mathbf{n}, \mathbf{x})}{c}\right). \text{ Substituting this solution to the wave}$$

equation we obtain the following equation for the velocity c and the polarization vector \mathbf{l} :

$$M\mathbf{l} = c^2\mathbf{l},$$

where M is matrix with elements depending on \mathbf{n} and the modules A, L, N, F, C . In general case (arbitrary direction of \mathbf{n}) the solution is too complicated, but it is simplified in the particular cases, when \mathbf{n} is directed along or perpendicular to z -axis:

- $n_z = 1, \quad n_x = n_y = 0$

$$\xi = \rho c^2$$

Equation for ξ

$$\xi^3 - (2L + C)\xi^2 + L(L + 2C)\xi - L^2C = 0 \quad (32)$$

has the solutions:

$$\xi_1 = C, \quad \xi_2 = \xi_3 = L,$$

$$\mathbf{l}_1 = \mathbf{n}, \quad (\mathbf{l}_2, \mathbf{n}) = 0, \quad (\mathbf{l}_3, \mathbf{n}) = 0, \quad (\mathbf{l}_2, \mathbf{l}_3) = 0$$

- $n_z = 0, \quad n_x^2 + n_y^2 = 1$

$$\xi^3 - (A + N + L)\xi^2 + (AN + LA + LN)\xi - LAN = 0 \quad (33)$$

$$\xi_1 = A, \quad \xi_2 = L, \quad \xi_3 = N$$

$$\mathbf{l}_1 = \mathbf{n}, \quad \mathbf{l}_2 = \mathbf{e}_z, \quad \mathbf{l}_3 = (\mathbf{n} \times \mathbf{e}_z)$$

The most unusual property of the waves in anisotropic medium is that the energy is transferred not in the direction of propagation. It is difficult to understand for plane

waves, but can be illustrated on the example of the waves propagating from a point source. Surfaces of constant phase at two different moments are shown below:

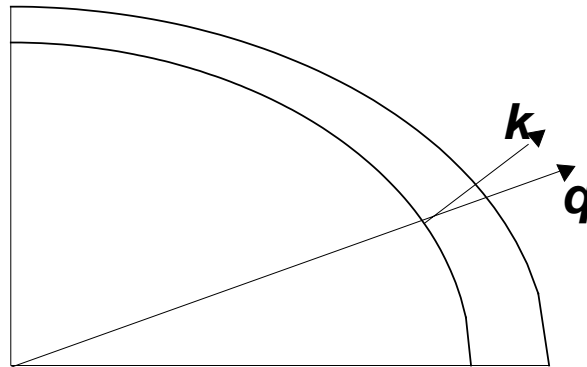

Vector $\mathbf{k}=\mathbf{n}/c$ is wave vector, and c is phase velocity. But the energy is transported along the ray $\mathbf{q}=\mathbf{n}'/u$, where u is group velocity. The group velocity and the direction of the energy transfer can be obtained using the vector of energy flux, which in general case is expressed as follows.

As was shown above,

$$W\mathbf{c} = -\mathbf{T}\dot{\mathbf{u}},$$

where \mathbf{c} is the velocity of the energy transport, i.e. *group velocity* (denote it $\mathbf{u}=\mathbf{u}\mathbf{n}'$)

Then

$$\mathbf{u}\mathbf{n}' = -(\mathbf{T}, \dot{\mathbf{u}})/W \quad (34)$$

From this relationship we can determine both group velocity and direction of the energy transport.

3. Propagation of elastic waves in media with boundaries

3.1. Boundary conditions

If the medium contains a boundary or discontinuity at which seismic velocity changes, the waves reflect or refract, i.e. some new waves are generated on the boundary. These waves must fit the *boundary conditions*. Boundary conditions relate stresses and displacements at the boundaries.

At *free surface* all stresses applied to the surface (so-called *tractions*) vanish, i.e. if the unit normal to the surface S is \mathbf{n} , then $(\mathbf{T}, \mathbf{n})_S = 0$.

Boundary conditions at interfaces between two solids may be different. The most usual condition is continuity of traction and displacement:

$$\begin{aligned} \mathbf{T}_n^{(1)} &= \mathbf{T}_n^{(2)} \\ \mathbf{u}^{(1)} &= \mathbf{u}^{(2)} \end{aligned} \quad (35)$$

These conditions correspond to the *welded contact*.

Another case is the so-called *sliding contact*. This corresponds to the case, when the media in contact are allowed to slide freely along the boundary. It means that the tangential component of traction vanishes, whereas normal components of both traction and displacement are continuous. No restrictions are placed on the tangential component of displacement:

$$\begin{aligned} \tau_{nn}^{(1)} &= \tau_{nn}^{(2)} \\ \tau_{nt}^{(1)} &= \tau_{nt}^{(2)} = 0 \\ u_n^{(1)} &= u_n^{(2)} \end{aligned} \quad (36)$$

Such contact may be realized if a thin fluid layer is placed between the media.

More general condition is the so-called *unwelded contact*. This includes (35) and (36) as particular cases. This contact can be also realized as before: if a thin ‘elastic’ layer with vanishing rigidity ($\mu \rightarrow 0$) is placed between the two media. Depending on the relation between the thickness of the layer h and the rigidity μ the contact tends to the welded or to sliding one. To derive the boundary condition on such contact we have to consider the conditions on both interfaces of the layer, and then assume $h \rightarrow 0$, $\mu \rightarrow 0$. The conditions at each interface are assumed as those for the welded contact.

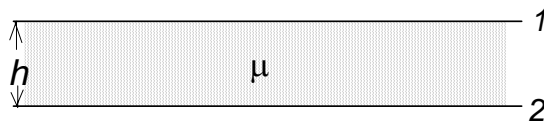

At the interface **1** the conditions are as (35):

$$\begin{aligned} \tau_{nn}^{(1)} &= \tau_{nn}^{(f1)} \\ \tau_{nt}^{(1)} &= \tau_{nt}^{(f1)} \\ u_n^{(1)} &= u_n^{(f1)} \\ u_t^{(1)} &= u_t^{(f1)} \end{aligned}$$

At the interface **2** the displacements and tractions in the layer are

$$\begin{aligned}\tau_{nm}^{(f2)} &= \tau_{nm}^{(f1)} + \frac{\partial \tau_{nm}^{(f1)}}{\partial n} h \rightarrow \tau_{nm}^{(f1)} \\ \tau_{nt}^{(f2)} &= \tau_{nt}^{(f1)} + \frac{\partial \tau_{nt}^{(f1)}}{\partial n} h \rightarrow \tau_{nt}^{(f1)} \\ u_n^{(f2)} &= u_n^{(f1)} + \frac{\partial u_n^{(f1)}}{\partial n} h \rightarrow u_n^{(f1)} \\ u_t^{(f2)} &= u_t^{(f1)} + \frac{\partial u_t^{(f1)}}{\partial n} h \rightarrow u_t^{(f1)} + \lim_{\substack{h \rightarrow 0 \\ \mu \rightarrow 0}} \frac{h}{\mu} \tau_{nt}^{(f1)}\end{aligned}$$

Eliminating the tractions and displacements in the layer we obtain the relationship between these quantities in the upper and lower solids:

$$\begin{aligned}\tau_{nm}^{(1)} &= \tau_{nm}^{(2)} \\ \tau_{nt}^{(1)} &= \tau_{nt}^{(2)} \\ u_n^{(1)} &= u_n^{(2)} \\ u_t^{(1)} + m \tau_{nt}^{(1)} &= u_t^{(2)}\end{aligned}\tag{37}$$

where $m = \lim_{\substack{h \rightarrow 0 \\ \mu \rightarrow 0}} \left(\frac{h}{\mu} \right)$.

If $m=0$ we obtain the welded contact, and if $m \rightarrow \infty$ the contact is sliding.

Alternative conditions for unwelded contact may be derived if we assume the layer between two solids as filled by a viscous fluid.

3.2. Incidence of a plane wave to a plane boundary

It is well known that if a plane wave impinges on a plane boundary, new derivative waves result. The number of them depends on a type of the boundary and on polarization of the wave. In all cases we shall assume the boundary to be horizontal ($z=0$), and the waveform in the incident plane wave to be

$$F\left(t - \frac{x \sin \alpha - z \cos \alpha}{c}\right)$$

so that the plane of incidence is $y=0$.

1. Free surface.

Scheme of the incident and reflected waves is shown below.

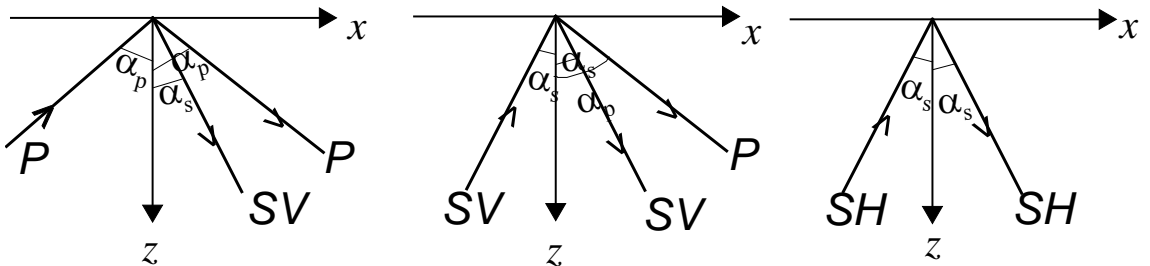

It is clear that to satisfy the boundary conditions we must assume the wave forms of the reflected waves the same as for the incident wave, i.e. $F(t)$. Also the argument of the function F should be the same at any point x of the boundary $z=0$. This requirement leads to the Snell's law:

$$\frac{\sin \alpha_p}{a} = \frac{\sin \alpha_s}{b} = \frac{1}{c}$$

where the meaning of c is an apparent velocity along the boundary.

If P or SV waves impinges to the surface, the displacements in the reflected P and SV waves are expressed as

$$\mathbf{u}_p = \kappa_p F\left(t - \frac{x \sin \alpha_p + z \cos \alpha_p}{a}\right)(\mathbf{e}_x \sin \alpha_p + \mathbf{e}_z \cos \alpha_p)$$

$$\mathbf{u}_s = \kappa_s F\left(t - \frac{x \sin \alpha_s + z \cos \alpha_s}{b}\right)(\mathbf{e}_x \cos \alpha_s - \mathbf{e}_z \sin \alpha_s)$$

where κ_p and κ_s are the *reflection coefficients*. They are determined from a linear system derived from the two boundary conditions

$$\tau_{xz} = 0, \quad \tau_{zz} = 0, \quad \text{at } z = 0$$

The system may be written in the matrix notation:

$$\mathbf{A} \begin{pmatrix} \kappa_p \\ \kappa_s \end{pmatrix} = \mathbf{b}$$

where the matrix \mathbf{A} is following:

$$\mathbf{A} = \begin{pmatrix} \sin 2\alpha_p & \gamma \cos 2\alpha_s \\ -\gamma \cos 2\alpha_s & \sin 2\alpha_s \end{pmatrix}, \quad \gamma = \frac{a}{b}$$

and the vector \mathbf{b} depends on the incident wave.

If P wave is incident,

$$b_1 = A_{11}$$

$$b_2 = -A_{12}$$

If S wave is incident

$$b_1 = A_{21}$$

$$b_2 = -A_{22}$$

The reflection coefficients depend on the angle of incidence. The most interesting case is when P wave reflected due to incidence of SV wave becomes inhomogeneous.

This case arises when $\sin \alpha_s > \frac{1}{\gamma}$. In this case $\cos \alpha_p = \sqrt{1 - (\gamma \sin \alpha_s)^2}$ becomes

imaginary, and the solution for P wave becomes complex. It is clear that the reflection coefficients for both P and S wave also become complex. Polarization vector

$\mathbf{n} = \mathbf{e}_x \sin \alpha_p + \mathbf{e}_z \cos \alpha_p$ for P wave also is complex. The amplitudes of the

coefficients for $\gamma = \sqrt{3}$ are shown below.

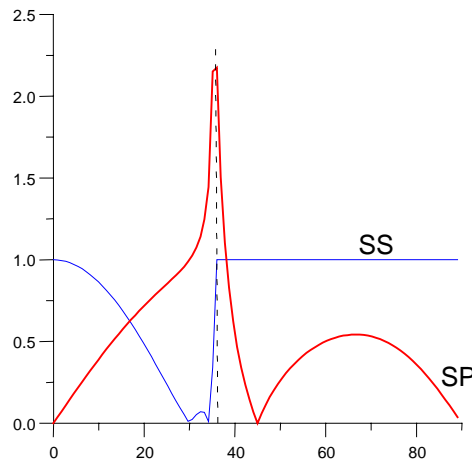

At overcritical angles ($\alpha_s > 35^\circ$) the modulus of the SS coefficient remains equal to 1, but its phase changes, though the wave remains to be homogeneous.

If, as was defined above, $f(x,y)$ and $g(x,y)$ are real and imaginary parts of the the function of a complex variable $F(z)=F(x+iy)$, then displacement in the reflected P wave at overcritical angles is

$$\mathbf{u}_p(t, x, z) = \text{Re} \left\{ (\kappa_1 + i\kappa_2) \left(f\left(t - \frac{x}{c}, \frac{z}{c} \sqrt{\gamma^2 \sin^2 \alpha_s - 1}\right) + ig\left(t - \frac{x}{c}, \frac{z}{c} \sqrt{\gamma^2 \sin^2 \alpha_s - 1}\right) \right) (\mathbf{e}_x \gamma \sin \alpha_s + i\mathbf{e}_z \sqrt{\gamma^2 \sin^2 \alpha_s - 1}) \right\}$$

For harmonic wave

$$\mathbf{u}_p(t, x, z) = \text{Re} \left\{ (\kappa_1 + i\kappa_2) (\cos[\omega(t - \frac{x}{c}) + i \sin[\omega(t - \frac{x}{c})]] (\mathbf{e}_x \gamma \sin \alpha_s + i\mathbf{e}_z \sqrt{\gamma^2 \sin^2 \alpha_s - 1}) \right\} e^{-\frac{\omega z}{c} \sqrt{\gamma^2 \sin^2 \alpha_s - 1}}$$

Particle motion in P wave for different angles of incidence is shown in the next figure. The motion is elliptic, prograde (as a rolling ball), and z -axis of the ellipse increases with the angle of incidence.

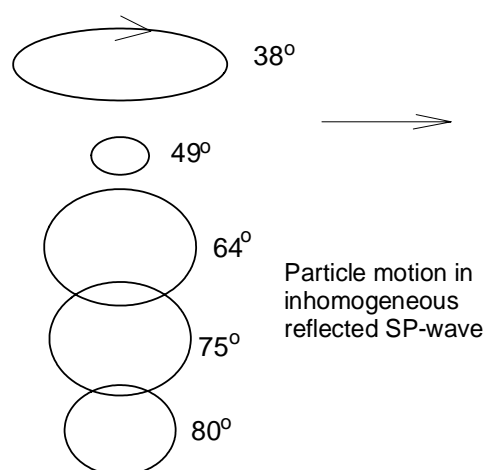

If P wave is incident, reflection coefficients are always real. The behavior of the coefficients with the angle of incidence is shown below.

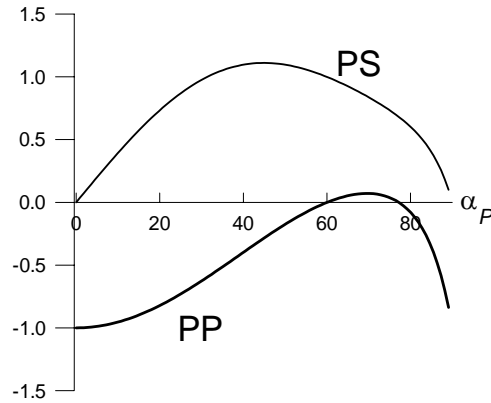

2. Interface between two solids.

If P or SV is incident to the boundary, four waves arise: reflected P and SV, and transmitted P and SV. In case of incidence of SH wave only two waves arise: reflected and transmitted SH. Reflection and transmission coefficients are determined from a system of linear equations resulting from the boundary conditions.

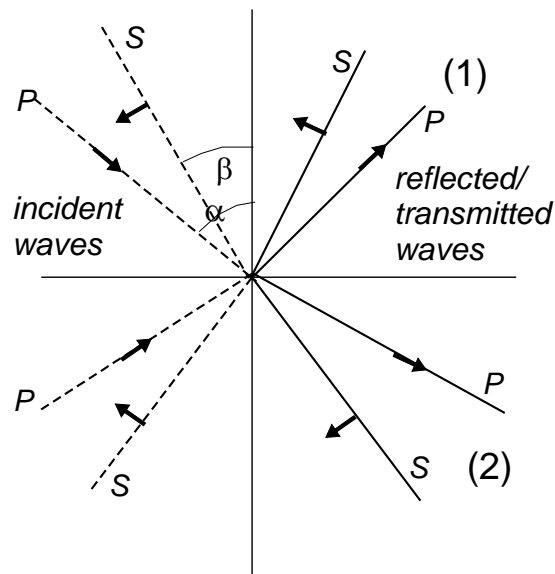

The system of equations for P-SV reflection/transmission coefficients in case of welded contact between the media (see the scheme above) has the following form:

$$\mathbf{A} \begin{pmatrix} \chi_{P1}^{(i)} \\ \chi_{S1}^{(i)} \\ \chi_{P2}^{(i)} \\ \chi_{S2}^{(i)} \end{pmatrix} = \mathbf{b}^{(i)},$$

where

$$\mathbf{A} = \begin{pmatrix} -\cos \alpha_1 & \sin \beta_1 & -\cos \alpha_2 & -\sin \beta_2 \\ \sin \alpha_1 & \cos \beta_1 & -\sin \alpha_2 & \cos \beta_2 \\ \frac{\mu_1}{a_1} \sin 2\alpha_1 & \frac{\mu_1}{b_1} \cos 2\beta_1 & \frac{\mu_2}{a_2} \sin 2\alpha_2 & -\frac{\mu_2}{b_2} \cos 2\beta_2 \\ -\rho_1 a_1 \cos 2\beta_1 & \rho_1 b_1 \sin 2\beta_1 & \rho_2 a_2 \cos 2\beta_2 & \rho_2 b_2 \sin 2\beta_2 \end{pmatrix},$$

and the vector \mathbf{b}_i in the right-hand side depends on the incident wave: it is formed by the i -th column of the matrix \mathbf{A} according to the rule $b_j^{(i)} = a_{ji}(-1)^j$ ($i=1(2)$ if P(S) wave is incident from the medium (1), $i=3(4)$ if P(S) wave is incident from the medium 2); the angles α and β correspond to P and S waves.

As mentioned above, the boundary conditions can be of different type, depending on the physical properties of the boundary. It is interesting to compare the coefficients for unwelded contact for different values of m . It is convenient to choose a dimensionless parameter instead of m , e.g. $\tilde{m} = \omega m \mu_1 / b_1$, where μ_1 and b_1 are rigidity and shear wave velocity in the medium where the incident wave propagates.

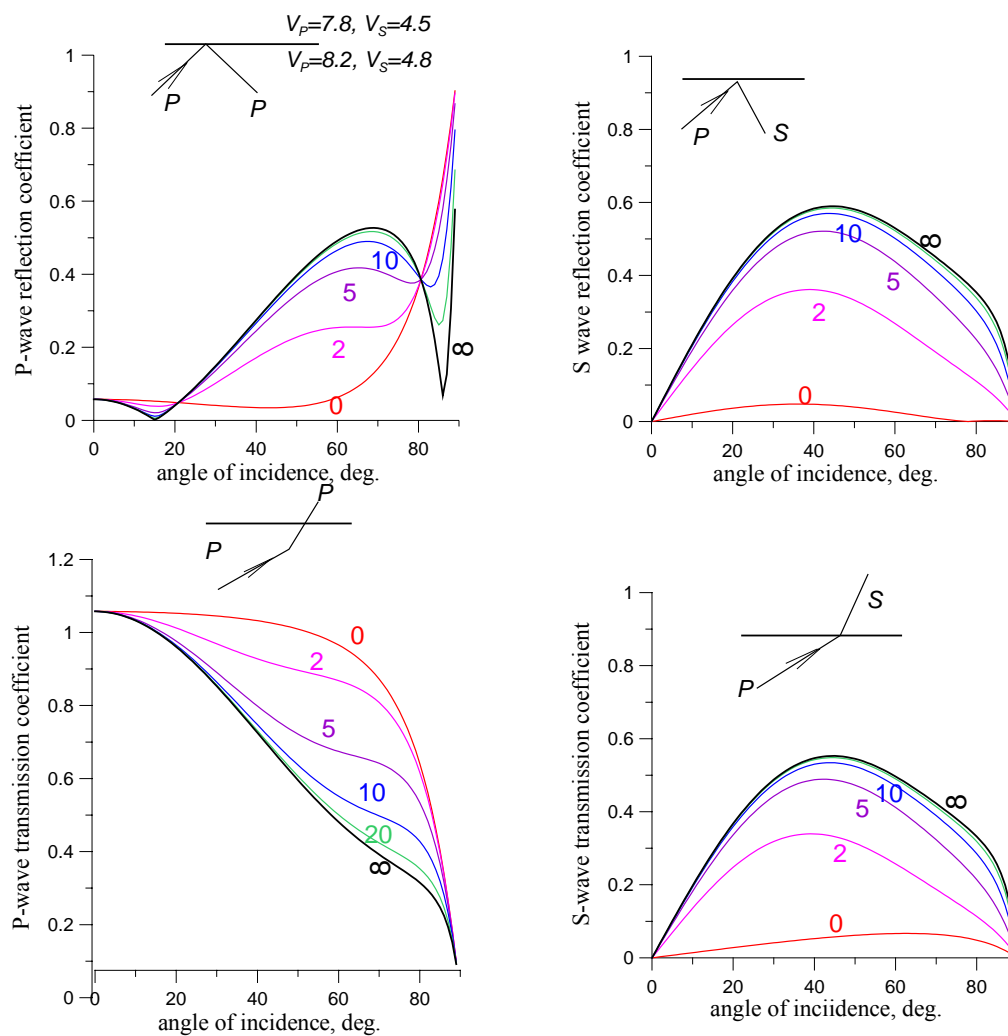

The figure above shows the reflection/transmission coefficients as functions of the angle of incidence for different values of \tilde{m} (remember that $\tilde{m} = 0$ corresponds to the welded contact, and $\tilde{m} = \infty$ to the sliding contact).

3.3. Head waves

If spherical wave is incident on a plane boundary, and a velocity of one of the reflected/transmitted waves is larger than that of the incident wave, a so-called *head wave* is formed on the boundary in addition to the transmitted and reflected waves. It is easier to understand generation of the head wave proceeding from the concept of the *wave fronts*. Let the disturbance in the source begins at $t=0$, then the surface $t=r/c$, where r is a distance from the source and c is wave velocity, separate the disturbed and non-disturbed areas. This surface is called the wave front.

Let the source be placed in the half-space **I**, the source radiates P-wave, and $a_2 > a_1$. At the boundary $z=0$ transmitted and reflected P and S waves are produced. The front of the reflected P wave is spherical, as of the incident wave, and the fronts of all other waves are spheroidal. While the front of the incident wave crosses the boundary under the angle less than critical ($\sin \alpha_p^{(1)} < \frac{a_1}{a_2}$), the wave fronts can be drawn as in

the fig.a. The fronts are closed in one point, which the disturbance reaches at a given moment. At the moments, when the angle of incidence exceeds the critical one, the picture of the wave fronts changes: the front of transmitted wave breaks away from this point and propagates in the half-space **2** along the boundary with larger velocity

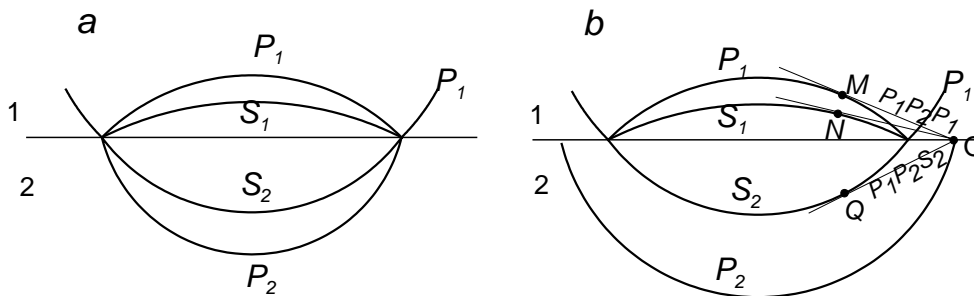

(fig.b).

In this case a part of the boundary between points A and O turns to be disturbed. This disturbance is radiated to the half-space **I** in a form of so-called head waves with conical fronts. The waveform of the head wave ($\psi(t)$) is the integral of the waveform of the incident wave ($f(t)$):

$$\psi(t) = \int_0^t f(\tau) d\tau \quad \psi(t) = \int_0^t f(\tau) d\tau$$

Amplitude of the head wave is determined by the formula:

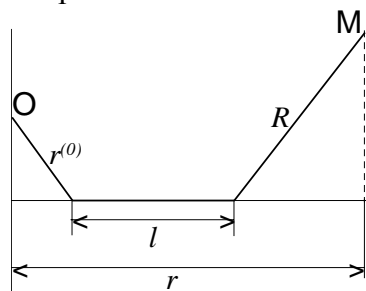

$$U_{head} = \Gamma \frac{\psi(t - \frac{r^{(0)} + R}{a_1} - \frac{l}{a_2}) \tan \alpha_{Perit}^{(1)}}{l^{3/2} \sqrt{r}}$$

where Γ is the coefficient of head wave generation, which is expressed in terms of reflection/transmission coefficients in the points A and B. If the types of incident, grazing and head waves are indicated by indices m, n, q , then

$$\Gamma_{mnq} = -\kappa_{nm}\kappa_{nq} \frac{\rho_n}{\rho_q \sin 2\alpha_q}$$

3.4. Rayleigh waves

In a half space with free surface exists a specific solution, which represents a superposition of *inhomogeneous* plane P and S waves. If we look for a solution in a form of a plane wave, the plane of incidence being $y=0$ (for simplicity we assume the dependence on time to be harmonic) then, according to the general representation of the inhomogeneous waves, we may write

$$\begin{aligned} \mathbf{u}_p(t, x, z) &= A \left(\frac{a}{c} \mathbf{e}_x - i \mathbf{e}_z \sqrt{\frac{a^2}{c^2} - 1} \right) \exp[i\omega(t - x/c)] \exp\left(-\omega z \sqrt{\frac{1}{c^2} - \frac{1}{a^2}}\right) \\ \mathbf{u}_s(t, x, z) &= B \left(i \mathbf{e}_x \sqrt{\frac{b^2}{c^2} - 1} + \frac{b}{c} \mathbf{e}_z \right) \exp[i\omega(t - x/c)] \exp\left(-\omega z \sqrt{\frac{1}{c^2} - \frac{1}{b^2}}\right) \end{aligned} \quad (38)$$

Replacing these expressions to the boundary conditions at the free surface $z=0$ we obtain a linear system for the amplitudes A and B of P and S waves. This system is homogeneous, therefore if non-zero solution exists, the determinant of the system should be equal to zero. This is

$$\left(2 - \frac{c^2}{b^2}\right)^2 - 4 \sqrt{1 - \frac{c^2}{a^2}} \sqrt{1 - \frac{c^2}{b^2}} = 0$$

Thus, the superposition of the waves (38) with A and B satisfying the boundary conditions (up to a constant multiplier) represent a wave propagating along x -axis and decaying exponentially along vertical direction.

Velocity of this wave along x -axis varies from $0.874b$ up to $0.956b$ for all possible values of b/a (from $\frac{1}{\sqrt{2}}$ to 0). It does not depend on frequency.

Motion in the Rayleigh wave is elliptic, retrograde at the surface and at shallow depths, but becomes to be prograde at large depths. The figure shows variation of the vertical (w) and horizontal (u) components with depth.

Ratio of horizontal and vertical amplitudes in Rayleigh waves at the surface is equal to $\frac{\sqrt[4]{1 - (c/b)^2}}{\sqrt[4]{1 - (c/a)^2}}$. It depends also only on the ratio b/a . For b/a varying from $\frac{1}{\sqrt{2}}$ to 0

this ratio varies from 0.786 to 0.541. For $b/a = \frac{1}{\sqrt{3}}$ it is equal to 0.681.

Rayleigh wave can be generated by a point source in the half-space, because the spherical wave radiated by such source may be represented as a superposition of both homogeneous and inhomogeneous plane waves. So it contains the waves with the apparent velocity equal to the velocity of Rayleigh wave.

3.5. Love waves

Inhomogeneous SH wave cannot exist in a half-space with free surface, because it is impossible to satisfy the boundary condition by only one wave – this can be done only if its amplitude is equal to zero. But if we have a layer with S wave velocity less than in the underlying half-space, than the waves can propagate along the boundary, amplitude of which decays with depth in the half-space. These are *Love waves*.

Love wave is formed by homogeneous waves within the layer and by inhomogeneous waves in the half-space. Therefore the apparent velocity of Love wave should be within the limits $b_1 \leq c \leq b_2 <$ because $\frac{1}{c} = \frac{\sin \alpha_{s1}}{b_1} = \frac{\sin \alpha_{s2}}{b_2}$, and

$1 \geq \sin \alpha_{s1} \geq \frac{b_1}{b_2}$. These waves should satisfy the boundary conditions at the free

surface and at the interface.

Again we shall construct the solution as a superposition of plane waves.

In the layer (homogeneous plane waves)

$$V_1 = A \exp[i\omega(t - \frac{x}{c} - z\sqrt{\frac{1}{b_1^2} - \frac{1}{c^2}})] + B \exp[i\omega(t - \frac{x}{c} + z\sqrt{\frac{1}{b_1^2} - \frac{1}{c^2}})]$$

In the half-space (inhomogeneous waves)

$$V_2 = C \exp[i\omega(t - \frac{x}{c} + iz\sqrt{\frac{1}{c^2} - \frac{1}{b_2^2}})]$$

It should be noted that in this case polarization vector is real (directed along y-axis), because the real part (\mathbf{I}_1) is orthogonal to z-axis. So, if we recall the relationship between the components (16), we can see that $\cos\beta=0$, so that $\mathbf{I}_2=0$.

These waves should satisfy the boundary conditions at the free surface and at the interface.

At the free surface ($z=0$)

$$\tau_{zy} = \mu_1 \frac{dV}{dz} = -i\mu_1\omega \sqrt{\frac{1}{b_1^2} - \frac{1}{c^2}} (A - B) \exp[i\omega(t - x/c)] = 0$$

where from $A=B$. So the solution in the layer may be written as

$$V_1 = 2A \cos\left(\omega z \sqrt{\frac{1}{b_1^2} - \frac{1}{c^2}}\right) \exp[i\omega(t - x/c)]$$

At the interface $z=H$

$$V_1(H) = V_2(H) \Rightarrow 2A \cos\left(\omega H \sqrt{\frac{1}{b_1^2} - \frac{1}{c^2}}\right) = C \exp\left(-\omega H \sqrt{\frac{1}{c^2} - \frac{1}{b_2^2}}\right)$$

$$\tau_{zy}^{(1)}(H) = \tau_{zy}^{(2)}(H) \Rightarrow -2A\mu_1\omega \sqrt{\frac{1}{b_1^2} - \frac{1}{c^2}} \sin\left(\omega H \sqrt{\frac{1}{b_1^2} - \frac{1}{c^2}}\right) = -C\mu_2\omega \sqrt{\frac{1}{c^2} - \frac{1}{b_2^2}} \exp\left(-\omega H \sqrt{\frac{1}{c^2} - \frac{1}{b_2^2}}\right)$$

It follows from these equations that

$$\tan\left(\omega H \sqrt{\frac{1}{b_1^2} - \frac{1}{c^2}}\right) = \frac{\mu_2 \sqrt{\frac{1}{c^2} - \frac{1}{b_2^2}}}{\mu_1 \sqrt{\frac{1}{b_1^2} - \frac{1}{c^2}}} \quad (39)$$

This is *dispersion equation* for Love wave velocity: unlike to Rayleigh waves in a half-space the velocity depends on frequency.

It is easy to show analytically that $b_1 \leq c \leq b_2$ (as concluded above from simple physical consideration). In fact, only in this case left and right sides of the dispersion equation are real.

It is also easy to show that for a *given* c there are infinite numbers of frequencies satisfying the dispersion equation. In fact,

$$\omega H = \frac{1}{\sqrt{\frac{1}{b_1^2} - \frac{1}{c^2}}} a \tan\left[\frac{\mu_2 \sqrt{\frac{1}{c^2} - \frac{1}{b_2^2}}}{\mu_1 \sqrt{\frac{1}{b_1^2} - \frac{1}{c^2}}}\right] + k\pi, \quad k = 1, 2, 3, \dots$$

Also we can show that for any *given* ω there are finite number of c . The Eq. (39) may be written as

$$f_2(c, \omega) = f_1(c)$$

A graph for the right-hand side is drawn by solid line. And the graph of the left-hand side behaves as \tan - at the values of argument $\frac{\pi}{2} + k\pi$ it tends to $\pm\infty$. But the rate of change depends on ω . At the figure below the graphs for the left-hand side are shown for two different values of ω . It is clear that for small ω there is only one root, and the number of roots increases with increase of ω .

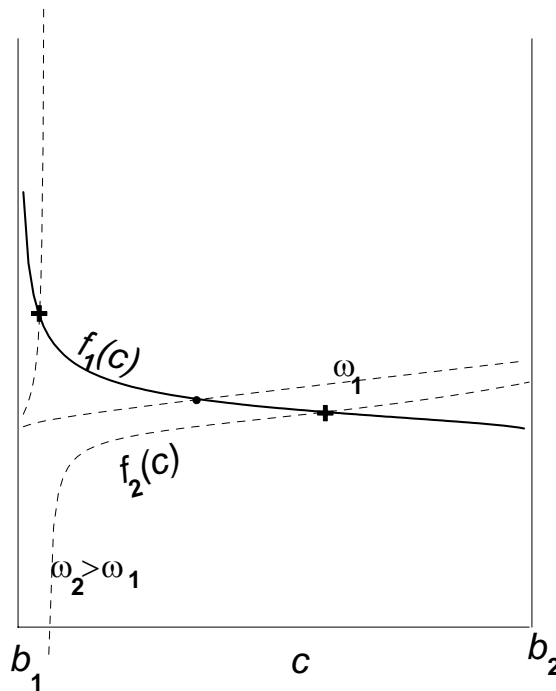

4. Waves in anelastic media

4.1. Constitutive equations

Real solids are not perfectly elastic. This causes seismic processes (waves, oscillations) to attenuate with time due to various energy-loss mechanisms. The most usual explanation of these mechanisms is internal friction between microscopic particles of the material, which leads to transformation of mechanical energy to heat.

The simplest description of attenuation due to ‘friction’ can be developed for an oscillating mass on a spring: this is a phenomenological model for seismic attenuation.

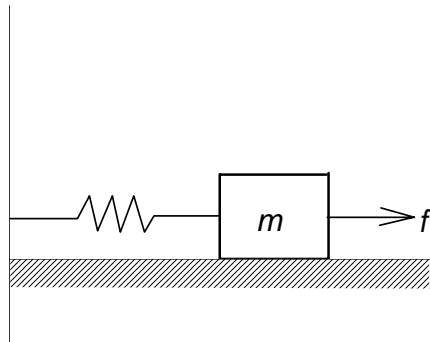

Let x be a deviation of the mass from the equilibrium. The force f is friction opposing the motion of the mass. Denote K a measure of the spring's stiffness.

The motion of the mass is

$$m\ddot{x} - F = 0$$

If friction is absent, and oscillation results only from elastic force, $F = -kx$,

$$m\ddot{x} + kx = 0,$$

and we obtain harmonic oscillation:

$$x = A \sin(\omega t + \varphi), \quad \omega = \sqrt{K/m}$$

However, if there is a friction between the moving mass and the underlying surface, and this force is proportional to the velocity of mass, so that the total force is

$$F = -kx - \gamma \dot{x},$$

then the oscillation attenuate:

$$x = e^{-\beta t} e^{i\omega t}$$

where $\beta = \frac{\gamma}{2m}$, $\omega = \sqrt{\frac{K}{m} \sqrt{1 - \frac{\beta^2 m}{K}}}$

Motion in a solid fits the equation

$$\nabla \mathbf{T} = \rho \frac{\partial^2 \mathbf{u}}{\partial t^2}$$

where \mathbf{T} is stress tensor. To solve this equation for any particular case it is necessary to express the stress in terms of displacement and its derivatives. In perfectly elastic

medium this relation is expressed by the Hooke's law. As shown above, in the case of homogeneous isotropic medium the equation of motion is reduced to the following

$$(\lambda + 2\mu)\nabla\text{div}\mathbf{u} - \mu\text{rotrot}\mathbf{u} = \rho\frac{\partial^2\mathbf{u}}{\partial t^2},$$

The solution is non-attenuated wave.

In realistic media the relationship between stress and strain is more complicated than that corresponding to the Hooke's law. Various properties of realistic materials lead to different relationships between stress and strain, – so-called *constitutive equations*, – which describe behaviour of the material when a stress is applied. A constitutive equation defines *rheological model*.

We consider the main rheological models used for analysis of oscillations and waves in solids.

Kelvin-Voight (viscoelastic) model. This model assumes existence of viscous coupling between particles in addition to elastic forces. Viscous forces are proportional to the velocity of strain. The relationship between stress and strain is as follows:

$$\tau_{ik} = \mu\varepsilon_{ik} + \eta\frac{\partial\varepsilon_{ik}}{\partial t}$$

$$\sigma_{ii} = \lambda\theta + 2\mu\varepsilon_{ii} + \eta'\frac{\partial\theta}{\partial t} + 2\eta\frac{\partial\varepsilon_{ii}}{\partial t}$$

($\theta = \text{div}\mathbf{u}$)

This model can be represented by a simple mechanical analogue: elastic element (spring) and viscous element (a piston pressed into viscous fluid) connected in parallel. If we apply a stress to such system at some moment, the strain arises not immediately, but increases gradually. The same happens if the stress is suddenly taken away: the strain would vanish gradually.

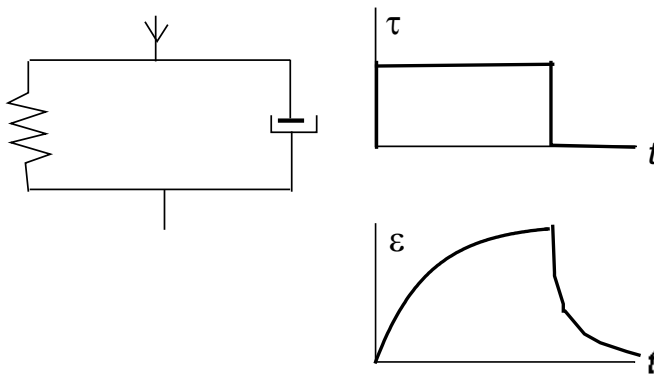

The relationship between stress and strain may be written in another form:

$$\tau = \mu\left(\varepsilon + T_\varepsilon\frac{d\varepsilon}{dt}\right)$$

The strain under constant stress relaxes:

$$\varepsilon = \varepsilon_0 \left(1 - e^{-t/T_\varepsilon}\right)$$

T_ε is the relaxation time. For small T_ε we obtain the Hooke's law.

Maxwell model. This model is a particular case of the so-called *after-effect models*, in which the stress is assumed to relate not only with the strain at the same moment, but also with the history of strain behaviour at previous time:

$$\tau_{ik} = \mu \varepsilon_{ik} - \int_0^\infty \varphi(\xi) \varepsilon_{ik}(t - \xi) d\xi \quad (40)$$

$\varphi(\xi)$ is the so-called *creeping function*. Various rheological models correspond to various creeping function.

If $\varphi(\xi) = \frac{\mu}{T_\tau} \exp(-\xi / T_\tau)$ (for pressure the Hooke's law is kept), we obtain the

Maxwell model. Substituting this function to the formula (40) and integrating by parts, we obtain

$$\frac{d\tau}{dt} + \frac{\tau}{T_\tau} = \mu \frac{d\varepsilon}{dt}$$

The constant T_τ is the relaxation time of stress under a constant strain:

$$\tau = \tau_0 \exp(-t / T_\tau)$$

The Maxwell model is valid only for shear strain. The figure below shows the mechanical analogue of the Maxwell model, as well as behavior of strain under a constant stress,

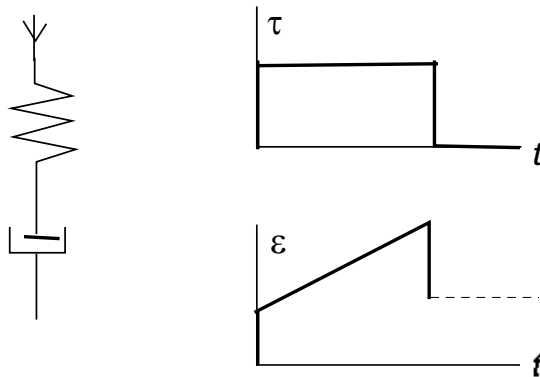

Standard linear solid. This model combines the both dissipation mechanisms, so that the relationship between stress and strain is following:

$$\tau + T_\tau \frac{d\tau}{dt} = \mu \left(\varepsilon + T_\varepsilon \frac{d\varepsilon}{dt} \right)$$

Mechanical analogue of this model is shown below:

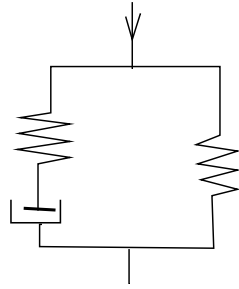

In this model the strain is relaxed under a constant stress, and the stress is relaxed under a constant strain.

4.2. Propagation of harmonic waves.

It is possible to derive the equation of motion in a form

$$\mathbf{L}(\mathbf{u}) = \rho \frac{\partial^2 \mathbf{u}}{\partial t^2}$$

only in some particular cases of anelasticity, - for example for viscoelastic medium.

But

it is easy to study propagation of harmonic waves in any linear model.

Let us consider harmonic oscillation in various rheological models:

$$\mathbf{u} = \mathbf{u}(\mathbf{r}) \exp(i\omega t)$$

Time dependence of strain is of the same form:

$$\varepsilon = \varepsilon(\mathbf{r}) \exp(i\omega t)$$

For *Kelvin-Voight model*

$$\tau(\mathbf{r}, t) = \mu(1 + i\omega T_\varepsilon) \varepsilon(\mathbf{r}) \exp(i\omega t) = \mu(1 + i\omega T_\varepsilon) \varepsilon(\mathbf{r}, t)$$

For *Maxwell model*

$$(1 + i\omega T_\tau) \tau(\mathbf{r}, t) = \mu i\omega T_\tau \varepsilon(\mathbf{r}, t)$$

$$\tau(\mathbf{r}, t) = \frac{i\omega T_\tau \mu \varepsilon(\mathbf{r}, t)}{(1 + i\omega T_\tau)}$$

For *standard linear solid*:

$$\tau(\mathbf{r}, t) = \mu \frac{(1 + i\omega T_\varepsilon)}{(1 + i\omega T_\tau)} \varepsilon(\mathbf{r}, t)$$

This for all cases the relationship between stress and strain is formally coincides with the Hooke's law, but the elastic modules are complex and depend on frequency. The frequency dependence is different for different models. Therefore in analysis of wave propagation of harmonic waves in anelastic media we may formally use the inferences obtained for perfectly elastic medium.

Consider propagation of a plane harmonic wave along x -axis:

$$A(x, t) = A_0 \exp[i\omega(t - x/V)]$$

If the modules are complex, the wave velocity V should be also complex:

$$\frac{1}{\bar{V}} = \frac{1}{V(\omega)} - \frac{i}{V^*}$$

Then

$$A(x, t) = A_0 \exp\left(-\frac{\omega x}{V^*}\right) \exp[i\omega(t - x/V(\omega))] \quad (41)$$

This shows that the wave attenuates with distance, and its velocity depends on frequency:

$V = V(\omega)$. Attenuation and dispersion are the main properties of the waves propagating in anelastic media.

Using the wave number k we can represent the plane wave in the form

$$A(x, t) = A_0 \exp[i(\omega t - \bar{k}x)]$$

where the wave number \bar{k} is complex: $\bar{k} = k - ik^*$, so that the attenuation is determined by the exponential term $\exp(-k^*x)$, being the attenuation coefficient. It depends on frequency.

Quality factor. Instead of the attenuation coefficient k^* seismologists use the characteristics, which is called the quality factor Q . It is a measure of energy loss at a distance $k^{-1} = \frac{\lambda}{2\pi}$, where λ is the wave length:

$$Q^{-1} = \frac{\Delta E}{E} = \frac{\exp(-2k^*x) - \exp[-2k^*(x + k^{-1})]}{\exp(-2k^*x)} = 1 - \exp(-2k^*/k) \approx 2 \frac{k^*}{k}.$$

The larger Q , the more proximate the medium to the perfectly elastic. Because

$$k = \frac{2\pi}{VT}, \text{ then } Q^{-1} = \frac{k^*VT}{\pi}, \text{ and consequently, } k^* = \frac{\pi}{QVT}.$$

Thus, the term describing the attenuation is $\exp(-\frac{\pi}{QVT})$. In inhomogeneous medium, where both velocity and

Q are functions of coordinates, it is $\exp\left(-\frac{\pi}{T} \int \frac{ds}{QV}\right)$.

Now we show how the quality factor Q is expressed in terms of the real and imaginary parts of the complex modules, and how to relate it with the relaxation times. Consider a shear wave. The complex velocity is expressed through the complex shear module as follows:

$$\bar{V}^{-1} = \sqrt{\frac{\rho}{\mu + i\mu^*}} \approx \sqrt{\frac{\rho}{\mu}} \left(1 - \frac{\mu^*}{2\mu}\right)$$

It follows from $Q^{-1} = \frac{2k^*}{k}$ that $Q^{-1} = \frac{2(V^*)^{-1}}{V^{-1}} = \frac{\mu^*}{\mu}$. Knowing the expressions for complex modules for different rheological models we can write the quality factor as a function of frequency and relaxation times:

$$\text{For Kelvin-Voigt's model} \quad Q^{-1} = \omega T_\varepsilon.$$

$$\text{For Maxwell model} \quad Q = \omega T_\tau$$

$$\text{For standard linear solid} \quad Q^{-1} = \frac{\omega(T_\varepsilon - T_\tau)}{1 + \omega^2 T_\varepsilon T_\tau}$$

It seems that Q should noticeably change with frequency. However seismological observations indicate that Q does not practically depend on frequency over a large range of frequencies. This is because of a variety and scale of attenuation processes in real materials. The most general model is the standard linear solid, for which the frequency dependence of Q^{-1} is as follows:

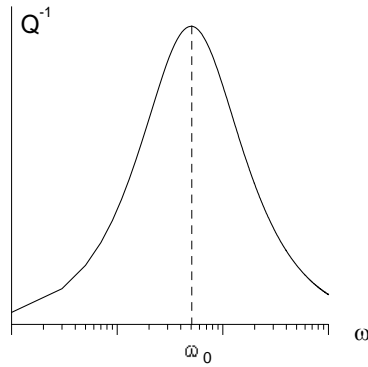

The peak in Q^{-1} is known as a *Debye peak*. It corresponds to the frequency

$$\omega_0 = \frac{1}{\sqrt{T_\varepsilon T_\tau}}, \text{ and the value of } Q^{-1} \text{ at this frequency is equal to } \frac{1}{2} \left(\sqrt{\frac{T_\varepsilon}{T_\tau}} - \sqrt{\frac{T_\tau}{T_\varepsilon}} \right).$$

The superposition of numerous Debye peaks for various relaxation processes, each with a different frequency range, produces a broad, flattened *absorption band*.

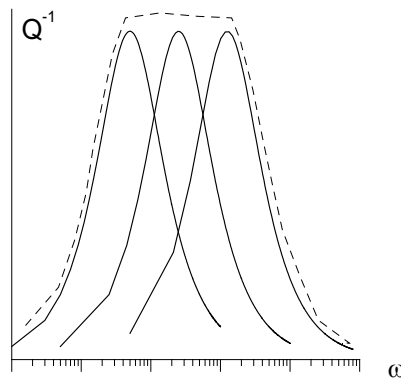

5. Excitation of the waves

In the elastodynamic theory a source of waves may be described in two ways: either by a body force in the right-hand side of the equation of motion, or by displacement / traction at a closed surface bounded a volume where a solution is looked for. We shall consider both these cases.

5.1. Body force

Let us consider the equation of motion for unbounded homogeneous isotropic medium, in which a source is given by a body force in the right-hand side of the equation:

$$(\lambda + 2\mu)\nabla\text{div}\mathbf{u} - \mu\text{rotrot}\mathbf{u} = \rho\frac{\partial^2\mathbf{u}}{\partial t^2} - \mathbf{f}(\mathbf{x},t) \quad (42)$$

Solution of this equation, as was mentioned earlier, can be represented as a superposition of different elementary solutions. We introduce a solution of the equation, in which the force is concentrated in a point $\boldsymbol{\xi}$, directed along q -axis, and acts with time as a pulse $\delta(t)$. Denote this solution as $\mathbf{g}^q(\mathbf{x},\boldsymbol{\xi},t)$ - it is the Green function for the elastodynamic equation. It satisfies the equation

$$(\lambda + 2\mu)\nabla\text{div}\mathbf{g}^q - \mu\text{rotrot}\mathbf{g}^q = \rho\frac{\partial^2\mathbf{g}^q}{\partial t^2} - \delta(\mathbf{x} - \boldsymbol{\xi})\delta(t)\mathbf{e}_q$$

If the pulse originates at the moment $t=\tau$, the solution is $\mathbf{g}^q(\mathbf{x},\boldsymbol{\xi},t-\tau)$.

The force $\mathbf{f}(\mathbf{x},t)$ which enters to the right-hand side of (42) can be represented as a superposition of the elementary sources, located at different points and arising at different moments, and subsequently, the solution of (42) can be represented as a superposition of the solutions $\mathbf{g}^q(\mathbf{x},\boldsymbol{\xi},t-\tau)$:

$$\mathbf{u}(\boldsymbol{\xi},t) = \int_{-\infty}^{\infty} d\tau \iiint_{V_{\boldsymbol{\xi}}^q} \sum f_q(\mathbf{x},\tau)\mathbf{g}^q(\mathbf{x},\boldsymbol{\xi},t-\tau)dV_x \quad (43)$$

This is the expression for the wave field due to body force with density $\mathbf{f}(\mathbf{x},t)$.

5.2. Boundary conditions; representation theorem

Now we consider a wave field in a volume V bounded by a surface S , if given are a displacement $\mathbf{U}_S(t)$ and a traction $\mathbf{T}_n(t)$ at S . The displacement $\mathbf{U}_S(t)$ and a traction $\mathbf{T}_n(t)$ cause a wave field within V . For simplicity we suppose that no body forces act within this volume. The wave field in V satisfies the equation

$$\nabla\boldsymbol{\tau} - \rho\frac{\partial^2\mathbf{U}}{\partial t^2} = 0 \quad (44)$$

As shown earlier, the Green function $\mathbf{g}^{(q)}(\mathbf{x},\boldsymbol{\xi},t-\tau)$ is a solution of the equation

$$\nabla\boldsymbol{\tau}^q - \rho\frac{\partial^2\mathbf{g}^q}{\partial t^2} = -\delta(\mathbf{x} - \boldsymbol{\xi})\delta(t-\tau)\mathbf{e}_q \quad (45)$$

where $\boldsymbol{\tau}^q$ is the stress tensor corresponding to the Green function.

Let \mathbf{T} and \mathbf{V} correspond to any two different solutions of (44) (no matter, with or without non-zero right-hand side), \mathbf{T} being a symmetric tensor. Then according to Gauss formula we obtain

$$\int_V \operatorname{div}(\mathbf{TV})dV = \int_S (\mathbf{TV}, \mathbf{n})dS \quad (46)$$

For symmetric tensor $(\mathbf{TV}, \mathbf{n}) = (\mathbf{T}_n, \mathbf{V})$ is true. Then

$$\int_V \operatorname{div}(\mathbf{TV})dV = \int_S (\mathbf{T}_n, \mathbf{V})dS$$

Now we apply (46) to the following combination

$$\int_V (\operatorname{div}(\boldsymbol{\tau}^q \mathbf{U}) - \operatorname{div}(\mathbf{T} \mathbf{g}^q))dV = \int_S ((\boldsymbol{\tau}_n^q, \mathbf{U}) - (\mathbf{T}_n, \mathbf{g}^q))dS$$

The terms in the left-hand side may be transformed as

$$\operatorname{div}(\mathbf{TV}) = (\nabla, \mathbf{TV}) = (\nabla \mathbf{T}, \mathbf{V}) + (\mathbf{T} \nabla, \mathbf{V})$$

Denote

$$I_1 = \int_S ((\nabla \boldsymbol{\tau}^q, \mathbf{U}) - (\nabla \mathbf{T}, \mathbf{u}^q))dS$$

$$I_2 = \int_S ((\boldsymbol{\tau}^q \nabla, \mathbf{U}) - (\mathbf{T} \nabla, \mathbf{u}^q))dS$$

To transform I_1 we replace $\nabla \boldsymbol{\tau}^q$ и $\nabla \mathbf{T}$ from the equations of motion:

$$\begin{aligned} & \int_V \left[\rho \left(\frac{\partial^2 \mathbf{g}^q}{\partial t^2}, \mathbf{U} \right) - (\mathbf{U}, \mathbf{e}_q) \delta(\mathbf{x} - \boldsymbol{\xi}) \delta(t - \tau) - \rho \left(\mathbf{g}^q, \frac{\partial^2 \mathbf{U}}{\partial t^2} \right) \right] dV = \\ & = -(\mathbf{U}(\boldsymbol{\xi}, t), \mathbf{e}_q) \delta(t - \tau) + \int_V \rho \frac{\partial}{\partial t} \left(\frac{\partial \mathbf{g}^q}{\partial t} \mathbf{U} - \frac{\partial \mathbf{U}}{\partial t} \mathbf{g}^q \right) dV \end{aligned}$$

Now let us integrate this expression over t from $-\infty$ to $+\infty$, and taking into account that the Green function as well as its time derivative vanish at $\pm\infty$, we obtain that the integral is equal to $-(\mathbf{U}(\mathbf{x}_0, \tau), \mathbf{e}_q)$.

Now we shall transform I_2 :

$$\begin{aligned} (\boldsymbol{\tau}^q, \mathbf{U}) &= \tau_{xx} \frac{\partial U_x}{\partial x} + \tau_{xy} \frac{\partial U_x}{\partial y} + \tau_{xz} \frac{\partial U_x}{\partial z} + \\ & \tau_{yx} \frac{\partial U_y}{\partial x} + \tau_{yy} \frac{\partial U_y}{\partial y} + \tau_{yz} \frac{\partial U_y}{\partial z} + \\ & \tau_{zx} \frac{\partial U_z}{\partial x} + \tau_{zy} \frac{\partial U_z}{\partial y} + \tau_{zz} \frac{\partial U_z}{\partial z} = \\ & = \lambda \operatorname{div} \mathbf{g} \operatorname{div} \mathbf{U} + \frac{\mu}{2} \sum \gamma_{ik} \Gamma_{ik} \end{aligned}$$

Because of symmetry of this expression in respect to \mathbf{U} and \mathbf{g} , we see that $I_2 = 0$.

So finally

$$(\mathbf{U}(\boldsymbol{\xi}, \tau), \mathbf{e}_q) = \int_{-\infty}^{\infty} dt \int_S [(\mathbf{T}_n(\mathbf{x}_S, t), \mathbf{g}^q(\mathbf{x}_S, \boldsymbol{\xi}, t - \tau) - (\boldsymbol{\tau}_n^q(\mathbf{x}_S, \boldsymbol{\xi}, t - \tau), \mathbf{U}(\mathbf{x}_S, t))] dS \quad (47)$$

This is the *representation theorem*.

It is widely used in analysis of seismic sources and in the theory of diffracted waves.

In general case, when body force $\mathbf{f}(\mathbf{x}, t)$ acts within the volume V , the wave field within this volume is represented as a sum of (43) and (47).

5.3. Green function for isotropic homogeneous medium

To apply the formulas (43) and (47) for determining the wave field it is necessary to know the Green tensor $\mathbf{g}^q(\mathbf{x}, \boldsymbol{\xi}, t)$. It should be noted that the Green tensor can be determined in different ways, depending on the boundary conditions at S . In case of a bounded volume it is convenient to assume either displacement or traction equal to zero at S , depending on which characteristics of the field (displacement or traction) is given at S . In case of unbounded medium it is sufficient to take into account the radiation condition. In general case of the medium the Green function can be determined only approximately, but in homogeneous isotropic medium the exact expression for the Green function exists. It can be easily obtained from the Stokes' formula for the wave field excited by a point force located in the origin of coordinates whose time function is $X(t)$:

$$\mathbf{u}(\mathbf{x}, t) = \frac{1}{4\pi\rho} \left[\frac{2\cos\theta}{R^3} \mathbf{e}_R + \frac{\sin\theta}{R^3} \mathbf{e}_\theta \right] \int_{R/a}^{R/b} \tau X(t-\tau) d\tau + \frac{\cos\theta}{4\pi\rho a^2 R} X(t-R/a) \mathbf{e}_R - \frac{\sin\theta}{4\pi\rho b^2 R} X(t-R/b) \mathbf{e}_\theta \quad (48)$$

The Green function $\mathbf{g}^q(\mathbf{x}, \boldsymbol{\xi}, t)$ is obtained from (48) if we replace $R = |\mathbf{x} - \boldsymbol{\xi}|$, $\cos\theta = (\mathbf{e}_q, \mathbf{e}_R)$, and $X(t) = \delta(t)$.

The first term in the right-hand side of (48) decays with distance more rapidly than the last two ones, so usually, if the source is far away from the point of observation, it is sufficient to consider only the second and the third terms.

5.4. Application of the representation theorem to analysis of diffracted waves

In this section we shall consider a simple example how the representation theorem is applied to the problems of diffraction of the waves. We shall analyze the waves diffracted at sharp ends of boundaries. The simplest example is the case when a plane wave impinges to an opaque boundary $x < 0$:

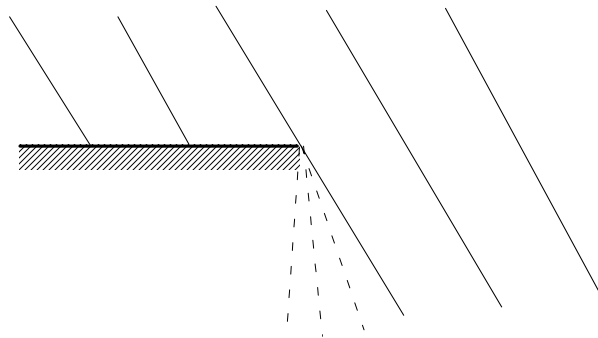

The edge $x=0$ can be regarded as a source for diffracted waves.

It is evident that diffracted waves should depend on frequency. Therefore we should analyze harmonic waves. For harmonic waves we may omit the term depending on time $\exp(-i\omega t)$, and analyze the solution $\mathbf{U}(\mathbf{x})$, which depends only on spatial coordinates. Analogously we eliminate such term from the Green's function, which would be now of the form $\mathbf{u}^q(\mathbf{x}, \xi)$. Representation theorem for this case is expressed as

$$(\mathbf{U}(\xi), \mathbf{e}_q) = \int_S [(\mathbf{T}_n(\mathbf{x}_S), \mathbf{g}^q(\mathbf{x}_S, \xi)) - (\tau_n^q(\mathbf{x}_S, \xi), \mathbf{U}(\mathbf{x}_S))] dS \quad (49)$$

Now we shall consider the following problem. An opaque half-plane screen, which does not transmit P-wave, is placed along xy -plane at $-\infty < x < -X$, $-\infty < y < \infty$. A plane wave is incident normally to this plane along positive direction of z -axis. We shall determine the wave field in the point $x=0$, $z=H$.

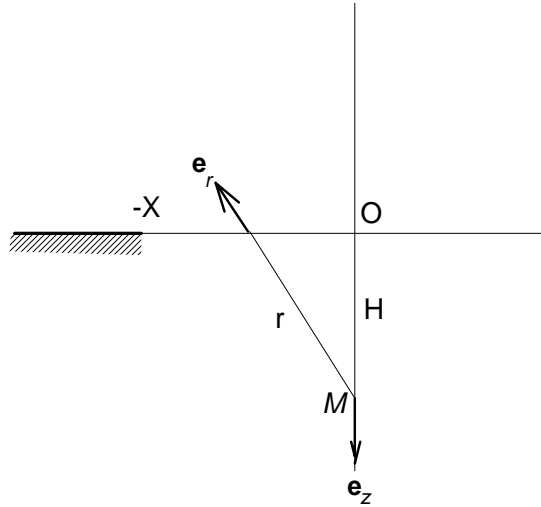

The incident wave is expressed as

$$\mathbf{U}(\mathbf{x}) = \mathbf{e}_z \exp(ikz)$$

where $k=\omega/a$. This is valid in the half-space $z < 0$. The stress at $z=0$ is $T_{zz} = (\lambda + 2\mu) \frac{\partial U_z}{\partial z} = ik(\lambda + 2\mu) \exp(ikz)$. But the outward normal to the boundary $z=0$ is $-z$, therefore at the boundary $\mathbf{T}_n = -\mathbf{T}_z = (0, 0, -ik(\lambda + 2\mu))$. The displacement at $z=0$ is $\mathbf{U}=(0,0,1)$.

For this particular case formula (49) has the following form:

$$U_z(M) = \int_{-X}^{\infty} \int_{-\infty}^{\infty} [(\mathbf{T}_n, \mathbf{g}^z(\mathbf{x}_S, M)) - (\tau_n^z(\mathbf{x}_S, M), \mathbf{U})] dx dy \quad (50)$$

To use the formula (50) we have to determine the Green's function and the corresponding stress. Assuming the frequency to be sufficiently high (the wavelength much smaller than the distance from the 'source' M to the boundary) we may keep only the main term in the Green's function (decaying as $1/R$). Then the field of P wave excited by a unit force placed at M and directed along z -axis is

$$\mathbf{g}^z(S) = \frac{1}{4\pi\rho a^2 r} \exp(ikr) (\mathbf{e}_z, \mathbf{e}_r) \mathbf{e}_r = -\frac{H}{4\pi\rho a^2 r^2} \exp(ikr) \mathbf{e}_r$$

$$g_z^z(S) = \frac{1}{4\pi\rho a^2 r} \exp(ikr) \frac{H^2}{r^2}$$

To calculate τ_{nz}^z we take into account that for high frequencies (and for large k) it is sufficient to differentiate in respect to r only the exponential term. Then

$$\tau_{nz}^z = \frac{ik}{4\pi\rho a^2 r} \exp(ikr) \left(\lambda \frac{H}{r} + 2\mu \frac{H^3}{r^3} \right)$$

Substituting all these expressions to (50) we obtain

$$U_z(M) = \frac{1}{4\pi\rho a^2} \int_{-\infty}^{\infty} \int_{-X}^{\infty} \left(-ik(\lambda + 2\mu) \frac{H^2}{r^2} - ik \left(\lambda \frac{H}{r} + 2\mu \frac{H^3}{r^3} \right) \right) \frac{\exp(ikr)}{r} dx dy$$

To estimate this integral we use the method of stationary phase. The stationary point is $x_{st} = y_{st} = 0$. In this point $r=H$. According to the method of stationary phase we represent the phase function as series in the vicinity of the stationary point and keep only terms of the second order. Then we obtain

$$\begin{aligned} U_z(M) &= -\frac{2ik(\lambda + 2\mu)}{4\pi\rho a^2 H} \exp(ikH) \int_{-\infty}^{\infty} \exp(ikr_{yy} y^2 / 2) dy \int_{-X}^{\infty} \exp(ikr_{xx} x^2 / 2) dx = \\ &= -\frac{ik}{2\pi H} \sqrt{\frac{2\pi i H}{k}} \exp(ikH) \int_{-X}^{\infty} \exp(ikx^2 / 2H) dx \end{aligned} \quad (51)$$

(It is taken into account that $r_{xx} = r_{yy} = \frac{1}{H}$).

The integral $\int_{-X}^{\infty} \exp(ikx^2 / 2H) dx$ can be expressed through the Fresnel integral

$$F(z) = \int_0^z \exp(i\pi t^2 / 2) dt$$

$$\int_{-X}^{\infty} \exp(ikx^2 / 2H) dx = \sqrt{\frac{\pi H}{k}} \left(F(\infty) - F\left(-\frac{kX^2}{\pi H}\right) \right) \quad (52)$$

Substituting (52) to (51), and taking into account that $F(\infty) = \sqrt{\frac{i}{2}}$, $F(-z) = -F(z)$

we finally obtain

$$U_z(M) = \exp(ikH) \left[\frac{1}{2} + \frac{e^{-i\pi/4}}{\sqrt{2}} F(X / R_F) \right]$$

where $R_F = \sqrt{\frac{\pi H}{k}}$ is the Fresnel radius. The modulus of this function is shown below.

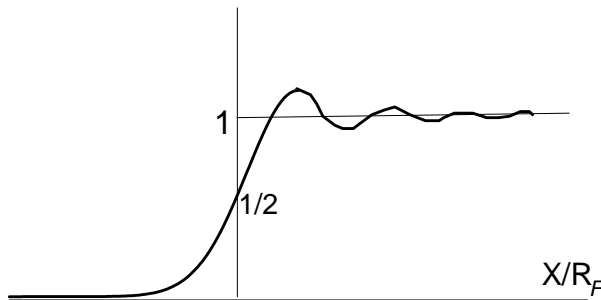

Thus, under the edge ($X=0$) the amplitude of the transmitted wave is twice as less of the amplitude of the incident wave. When the screen is moved to the left ($X>0$) the amplitude increases and exceeds that of the incident wave. If the screen is moved to the right, the amplitude decreases gradually to zero.

It is also possible to estimate a phase of the total transmitted wave. The total field may be represented as a superposition of 'pure' transmitted wave and diffracted wave. If the transmitted field is deducted from the total field, we obtain a field of the diffracted wave. It can be shown that a phase of this wave is approximately equal to $kR + \pi/4$, where R is a distance from the point M to the edge of the screen. Thus the edge of the screen may be regarded as a source of the diffracted wave.

