

Technical Capabilities for Fuel and Material Irradiation Testing at the Halden Reactor

T. Tverberg (terjet@hrp.no), W. Wiesenack, E. Kolstad, H. Thoresen, K. W. Eriksen, P. Bennett, T. M. Karlsen, N. W. Høgberg, R. Van Nieuwenhove

Institutt for energiteknikk

OECD Halden Reactor Project

B. C. Oberländer, H-J Kleemann, H. K. Jenssen

Institutt for energiteknikk

Workshop on Modelling and Quality Control for Advanced and
Innovative Fuel Technologies

Trieste, Italy, Nov 17 –18 2005



Contents

0. About the Halden Reactor Project and the Halden Reactor
1. Instruments and techniques for flux monitoring / control
 - a. Gamma flux measurements
 - b. Neutron flux measurements
 - c. Flux shielding / flux depression
 - He-3 coils
 - Moveable neutron shields



Contents (contd.)

2. Fuel rod instrumentation:

a. Thermocouples

- Fuel temperature
- Cladding temperature

b. The Linear Voltage Differential Transformer (LVDT)

- Fuel stack elongation detector EF
- Cladding extensometer EC
- Fuel rod pressure transducer PF
- Expansion thermometer ET (average fuel centre temperature)

c. Fuel rod gas flow/pressure lines

- Radioactive fission gas release, gas flow and overpressure

d. Re-instrumentation techniques



Contents (contd.)

3. Materials testing

- a. LWR loop systems
- b. Crack growth measurements with potential drop technique
- c. Crack initiation
- d. Clad diameter measurements
 - Cladding creep
 - PWR CRUD
- e. Stress relaxation



Contents (contd.)

4. Instrumentation development for materials studies
 - a. In-core conductivity cell
 - b. On-line potential drop corrosion monitor
 - c. Controlled distance electrochemistry measurements
 - d. Electrochemical impedance spectroscopy
 - e. ECP reference electrodes



Halden Reactor Project

- International co-operative effort
 - Hosted by Institutt for Energiteknikk

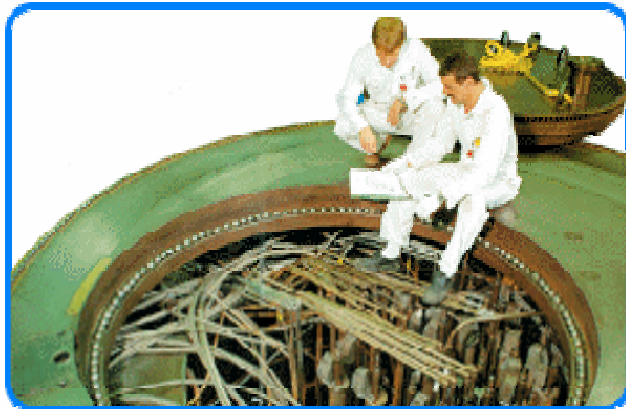

- Halden Heavy Boiling Water Reactor
 - Conditions provided for different types of reactors
 - Hot laboratory (Kjeller)
 - Available for contract work

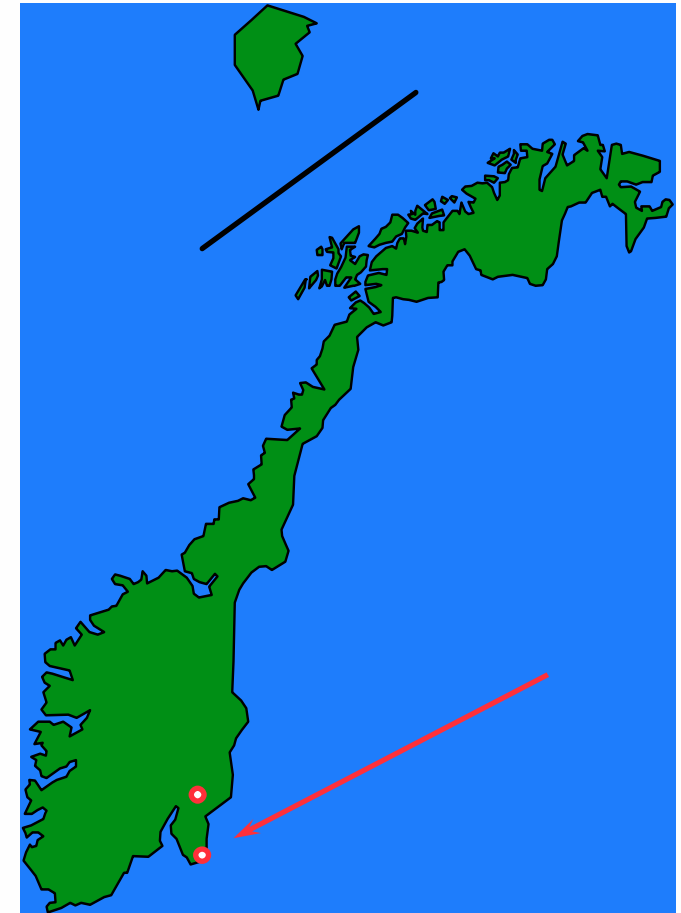

General Requirements for in-core Test Programs

A comprehensive assessment of fuels and materials performance requires:

1. Test reactor with flexible operation cycles
2. Ability to simulate operation conditions of commercial nuclear power stations
3. Capability to implement different modes of operation
4. Reliable and versatile in-core instrumentation
5. Re-fabrication and instrumentation of fuels and materials from commercial NPPs



Halden Boiling Water Reactor (HBWR)

Test reactor with flexible operation cycles

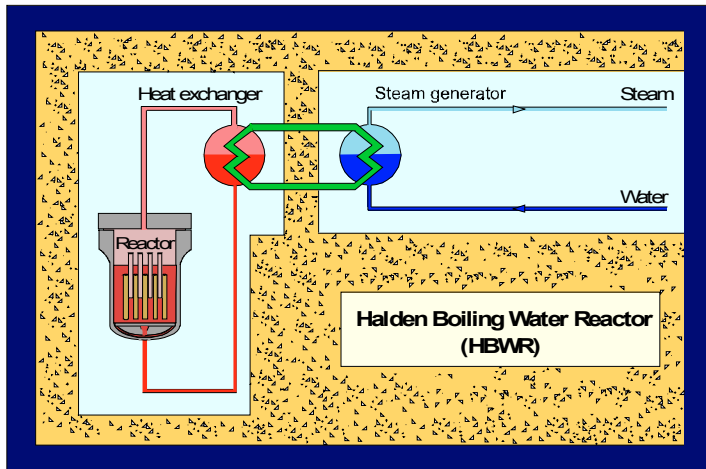

- **Solid containment: the reactor is located in rock**
- **Steam production for near-by paper mill (30t/h)**
- **Cooling of the reactor by natural circulation**
- Thermal power 20 MW
- Operating temperature 240 °C
- Operating pressure 33.6 bar
- BWR/PWR conditions are simulated in 10 loops
- 2 operation periods per year of about 100 days
- Systems for rod fuel rod and bellows pressurisation, gas flow, hydraulic drives etc.

**The Halden reactor - invisible in the mountain
in operation – producing data and steam**



HBWR Core Configuration

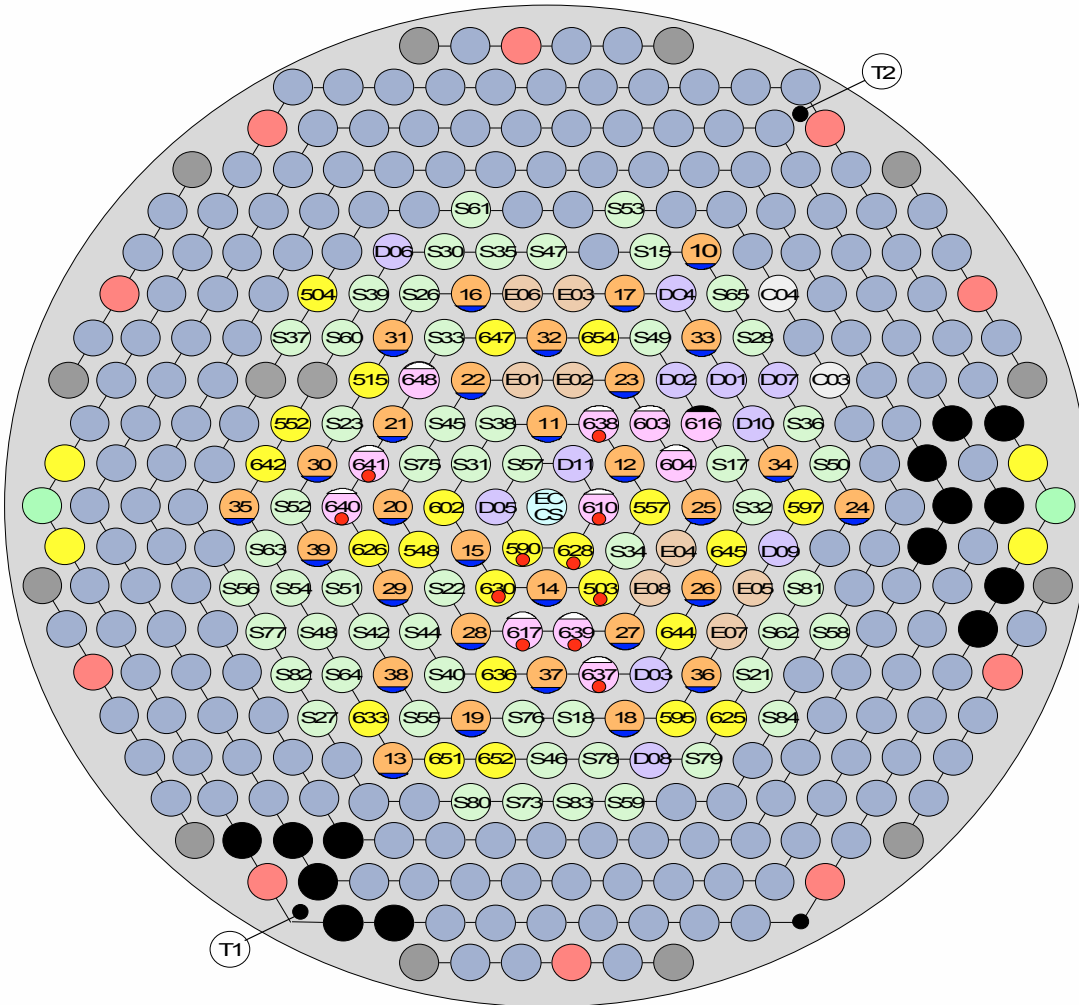

- More than 300 positions individually accessible
- About 110 positions in central core
- About 30 positions for experimental purposes (any of 110/300)
- Height of active core 80cm
- Usable length within moderator about 160cm
- Experimental channel Ø:
 - 70mm in HBWR moderator
 - 35-45mm in pressure flask
- Loop systems for simulation of typical thermal-hydraulic and chemistry conditions

Nuclear Calculations

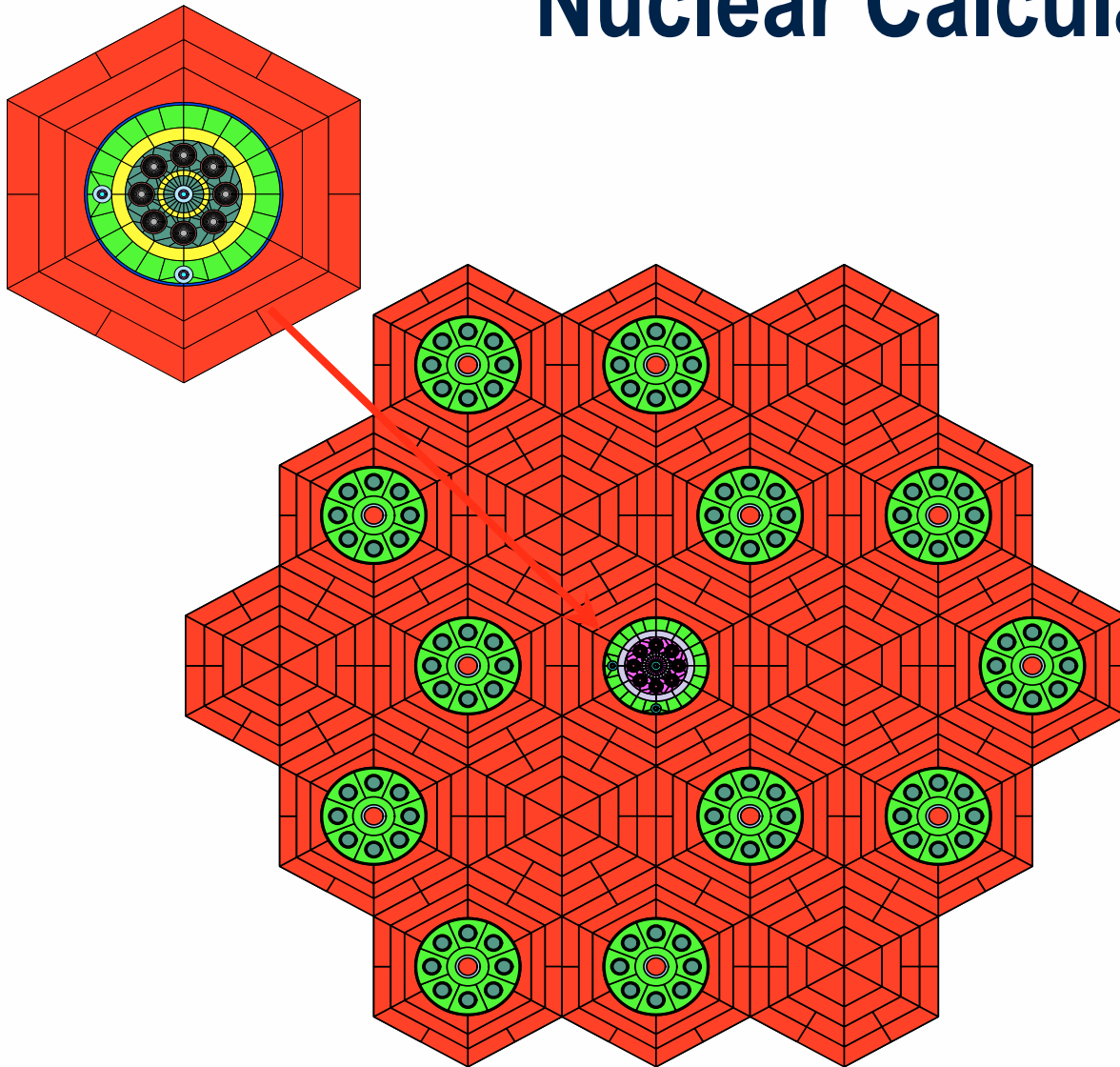

- Core physics evaluations utilise the HELIOS lattice code (2D transport)
- A test element is modelled with all important geometry and material details
- The test rig is inserted into a lattice with representative fuel elements
- Typical results:
 - power distribution
 - fuel depletion
 - fast flux
 - gamma heating
 - nuclear reaction rates

HBWR Nuclear Characteristics

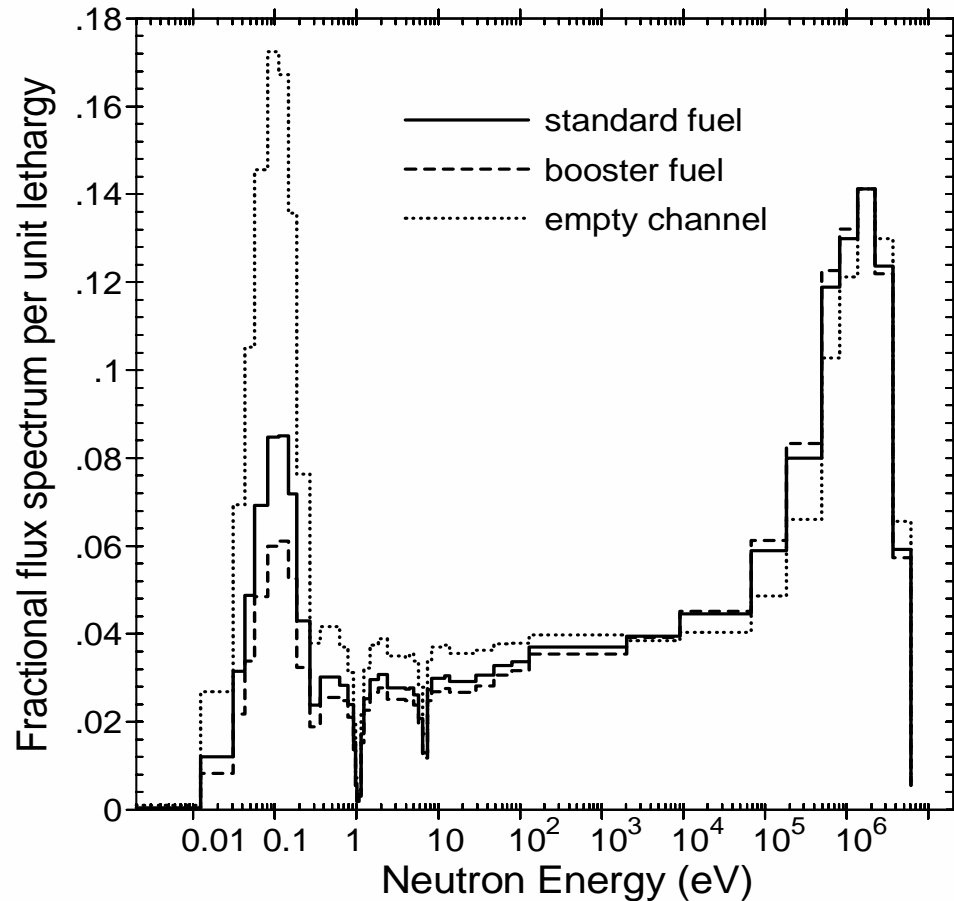

- Thermal power 20 MW
- Heavy water moderated and cooled (240 °C, 33.6 bar)
- Thermal neutron flux
 - 1 - 5·10¹³ n/cm²
 - 1.4·10¹⁴ in ramp configuration
- Fast neutron flux
 - 0.5 - 3.0·10¹³ depending on position and local power
 - 4 - 6·10¹³ in high power booster rigs



Application of Halden data

- Provide data for fuel behaviour model development, verification and validation
- Define starting conditions of transients and to assess the further developments
- Show compliance of fuel performance with design, operational and safety criteria
- Assess safety criteria with respect to available margins and reasonableness



HRP data acquisition systems

- 1967 IBM 1800 process control computer
- 1972 data acquisition system developed
- 1985 Test Fuel Data Bank TFDB
- 1988 IBM Series\1 + Norsk Data ND 100
on-line presentation, 5 min permanent
- 1996 G2 + workstations + Picasso II
1 min permanent
- 2005 G2 + PCs (Linux) + Picasso III

All data since 1972 available in a uniform format



Role of instrumentation

In-core instrumentation

is essential for fuels & materials performance studies, providing

- direct insight into phenomena while they are going on
- cross-correlations between interrelated phenomena

The Halden Project has more than 40 years of experience with in-core measurements and has perfected the instrumentation to function reliable in a demanding environment.



Performance of MOX fuel

Simultaneous measurement of temperature and pressure

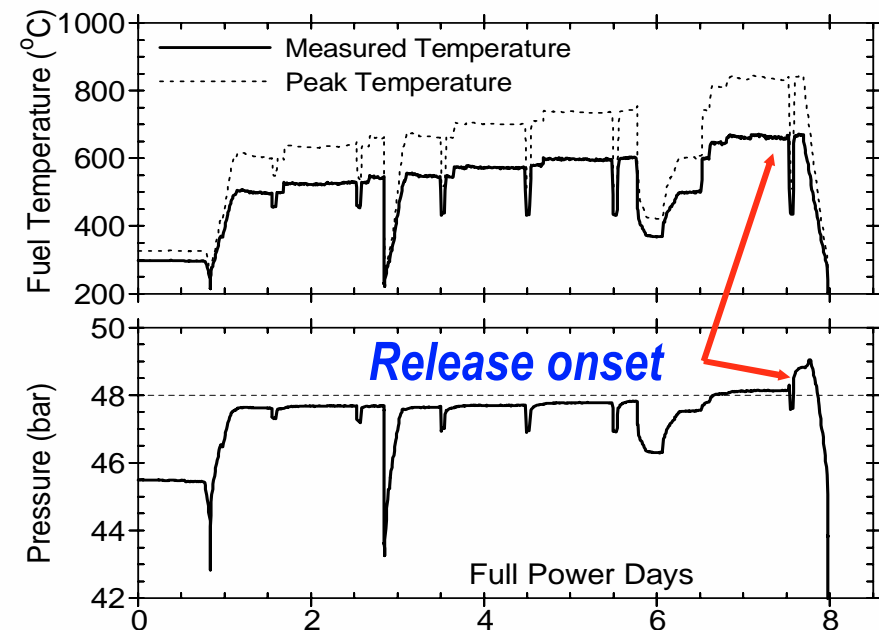

Basic in-core measurements, fuel

Primary Measurements

- Fuel temperature
- Rod pressure (fission gas release)
- Fuel stack length change
- Clad elongation (PCMI)
- Clad diameter
- Gap meter (squeezing technique)
- Neutron flux / power

Secondary Measurements

- Hydraulic diameter
- Gamma spectrometry (FGR)



Supplementary measurements in-core, on-line

- Fuel time constant (scram data)
- Noise data
 - Fuel temperature, time constant
 - Cladding elongation (PCMI)
- Gas flow capabilities
 - Hydraulic diameter (gap size)
 - (densification, long-term swelling)
- Fission product release
 - Radioactive species (ANS 5.4)
 - Assessment of S/V (microstructural changes)





SPECTRUM OF HALDEN REACTOR PROJECT FUELS & MATERIALS INVESTIGATIONS

FUEL		CLAD		Control Materials	Core Comp. Materials
<p><i>Standard UO₂</i> <i>UO₂ + additives</i> <i>MOX, inert matrix</i></p> <p>Fission gas release Fuel temperature - conductivity - stored energy Fuel densification Fuel swelling</p>	<p>Rod pressure, lift-off</p> <p>Gap conductance</p> <p>Axial gaps (clad collapse, power peaks)</p> <p>SCC/PCMI</p>	<p><i>Zirconium alloys</i></p> <p>Creep & Growth</p> <p>Failure Corrosion Crud, AOA</p>	<p>Rod/ guide tube bowing</p> <p>IRI</p> <p>Graphite</p>	<p><i>(B₄C)</i></p> <p>He release, pressure, swelling</p>	<p><i>Stainless steels</i> <i>Nickel base alloys</i></p> <p>Crack initiation & Time to failure Crack growth rate (IASCC) Mechanical prop. changes Embrittlement, annealing (RPV)</p>
<p><i>high burnup, operating conditions</i></p>				<p><i>water chemistry</i></p>	

Contents

1. Instruments and techniques for flux monitoring / control
 - a. Gamma flux measurements
 - b. Neutron flux measurements
 - c. Flux shielding / flux depression
 - He-3 coils
 - Moveable neutron shields



Flux measurements

Miniaturised γ -Thermometer

- Principle: Heat produced by gamma absorption in a thermally insulated body results in a local rise in temperature.
- Possible to re-calibrate in-core (low voltage DC current applied to the differential thermocouple).
- Pre-pressurised with Xe-gas.
- Designed and fabricated by the HRP

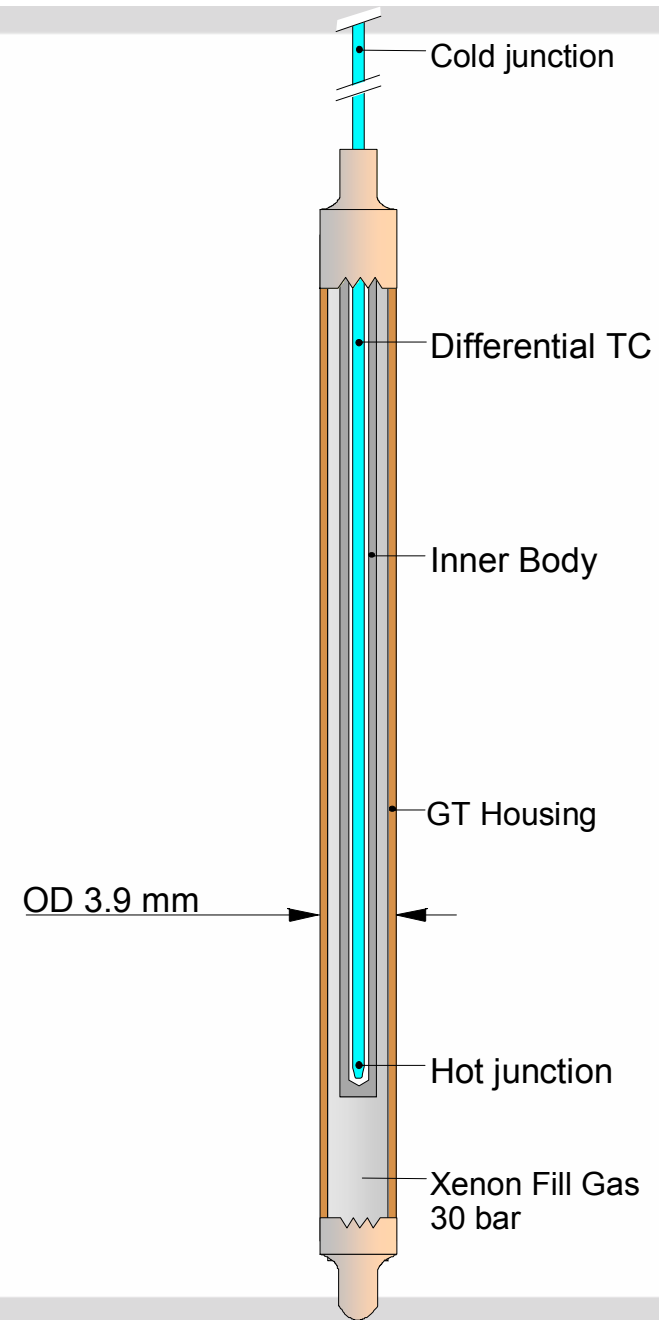

Determination of absolute gamma heating

1) Detailed finite element modeling

- accurate results because of simple geometry

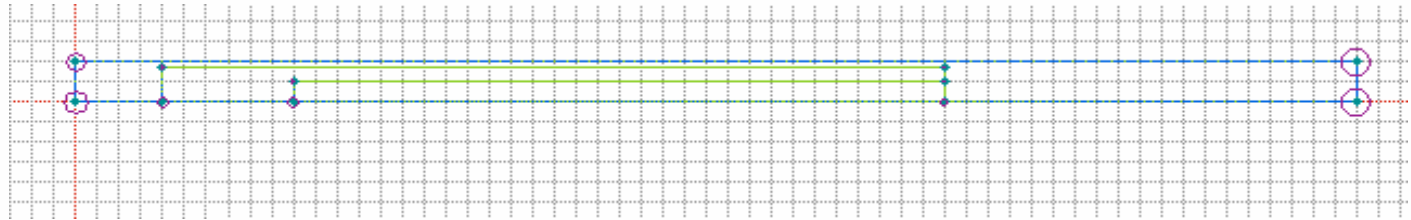

- fine meshing

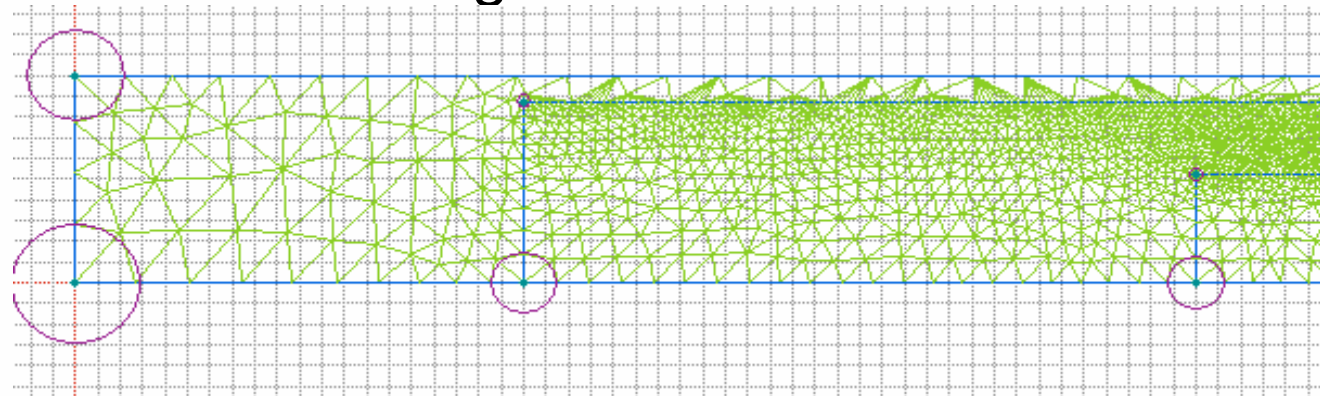

- Temperature dependent material properties
- Radiation losses included

Temperature distribution inside GT

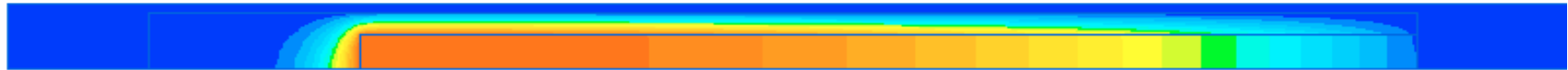

Temperature variation along inner body

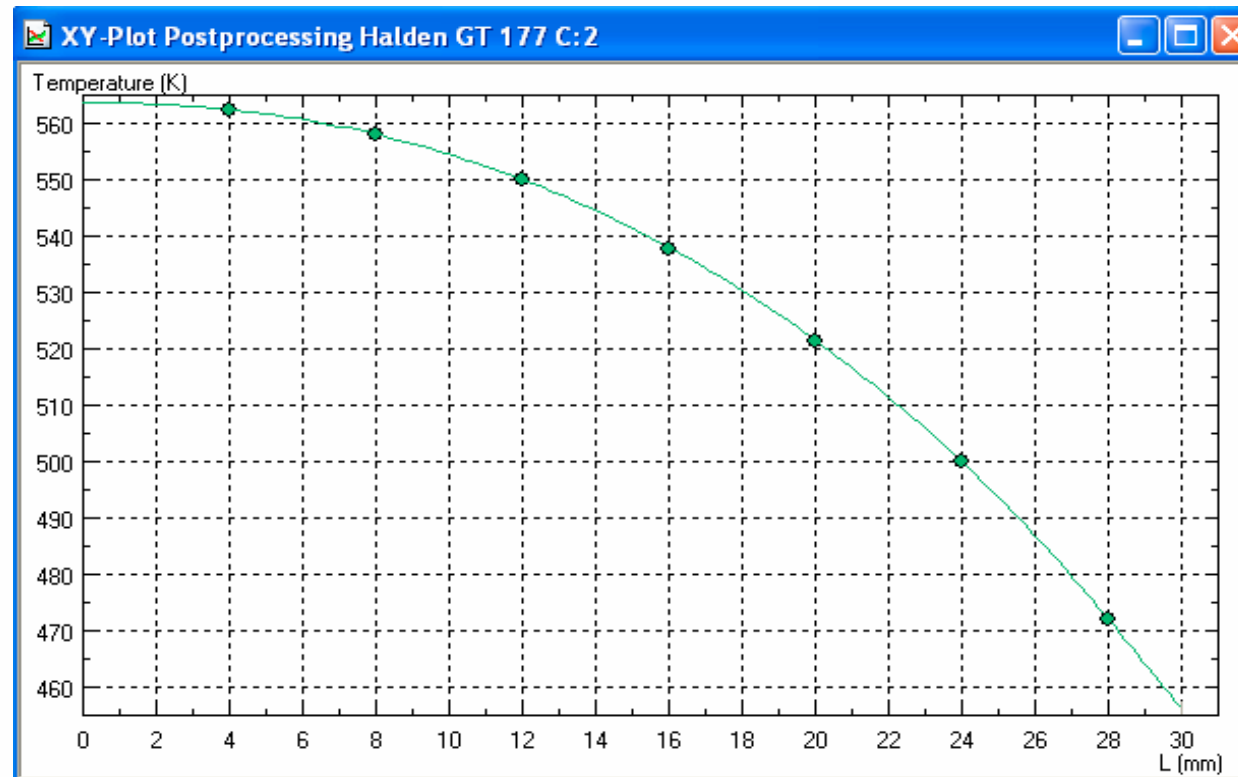

2) In-pile calibrations (experimental/theoretical)

- How ?
- Heat GT inner body by sending a current through the thermocouple
 - Switch off heating current
 - Record the decay of the temperature
 - Use relation between time constant and sensitivity (**based on theory !**)

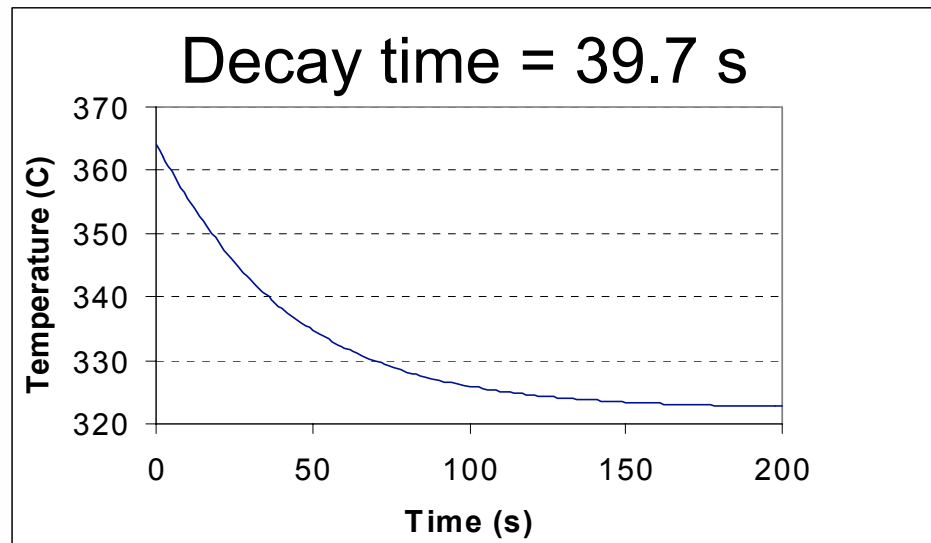

Flux measurements - Neutron

Self Powered Neutron Detectors

Used for power and / or neutron flux monitoring

- Typical emitter materials:
 - Vanadium
 - Rhodium
 - Cobalt (fast responding)
 - others
- Length (L) of emitter can be adjusted
- Designed and fabricated by the HRP

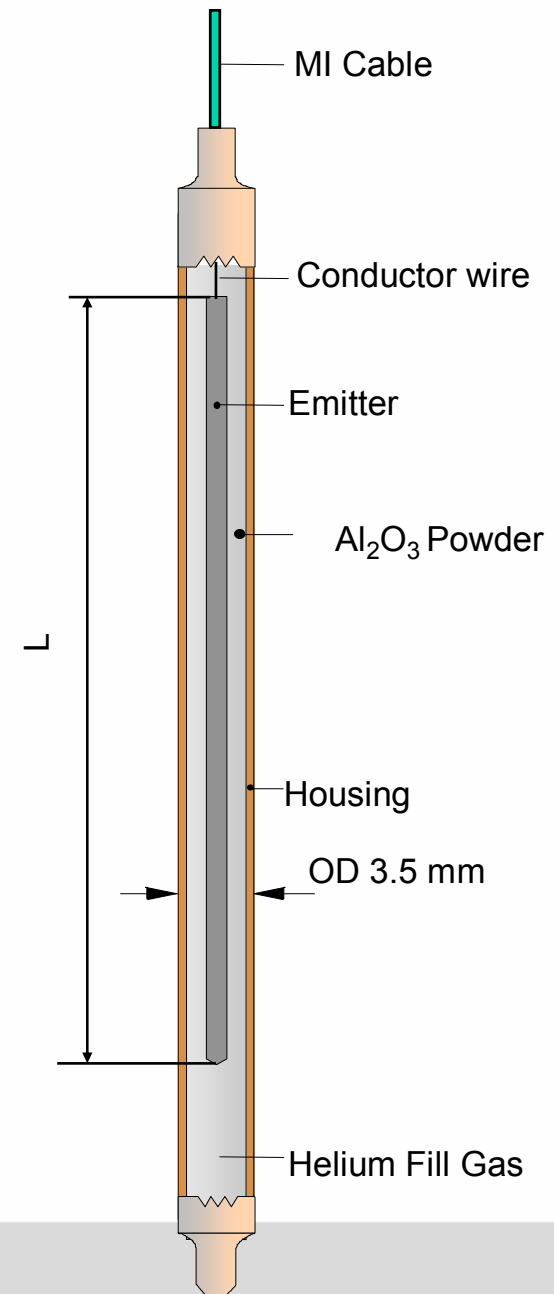

Different types of SPND's

Emitter Material (dia 1mm)	Sensitivity (10^{-22} A/(n.cm.s))	Burn-up (%) after 3×10^{21} n/cm ²	Response Time
Rh	20	34	68 s
Ag	14	17.4	51 s
V	1.8	1.5	5.4 min
Pt	0.9	2.7	prompt
Co	0.7	11.2	prompt



SPND as power monitor

Fuel rods mounted in a rig instrumented with thermocouples (inlet and outlet) and flowmeter to allow for **calorimetric** power determination

- Power calibration done at start of irradiation
- Note : Change of position in reactor or change of nearby fuel or control rod configuration may induce changes in the power calibration value.

Power = A x Neutron signal

To take into account the burn-up of the fuel rod :

Power = A x Neutron signal x Depletion coefficient (burn-up)



HELIOS- code



Digital dynamic compensation for delayed SPND's

Delayed SPNDs (R_h, V, \dots)  Problem to follow sudden flux changes ?

No, because the relevant decay processes are known, the response function is known very accurately. So, it is possible to filter out the response function.

- use the Autoregressive Moving Average method (ARMA)

Note : sampling time should be small enough ;
for example 2-15 s

See : *D. Hoppe and R. Maletti, Nucl. Sci. Eng. 111 (1992) 433-436*



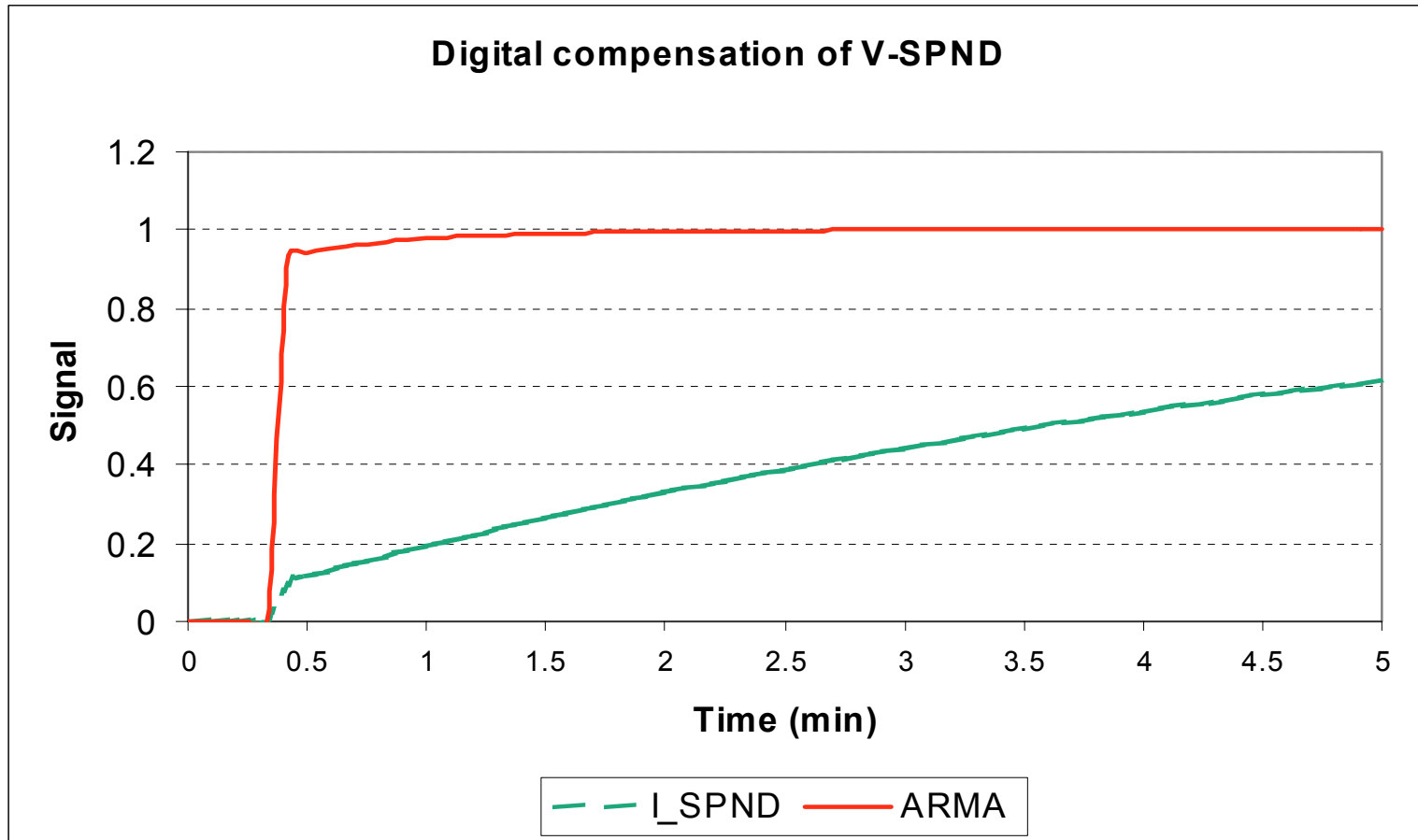

Raw and compensated V SPND signal with sudden flux rise at 0.41 min.
 With sampling time of 5 s : Response time (95 %) reduced from 16 m to 15 s

Note : The same procedure can of course be applied also for Gamma thermometer !



Contents (contd.)

2. Fuel rod instrumentation:

a. Thermocouples

- Fuel temperature
- Cladding temperature

b. The Linear Voltage Differential Transformer (LVDT)

- Fuel stack elongation detector EF
- Cladding extensometer EC
- Fuel rod pressure transducer PF
- Expansion thermometer ET (average fuel centre temperature)

c. Fuel rod gas flow/pressure lines

- Radioactive fission gas release, gas flow and overpressure

d. Re-instrumentation techniques



Example of instrumented test rig (transient testing)

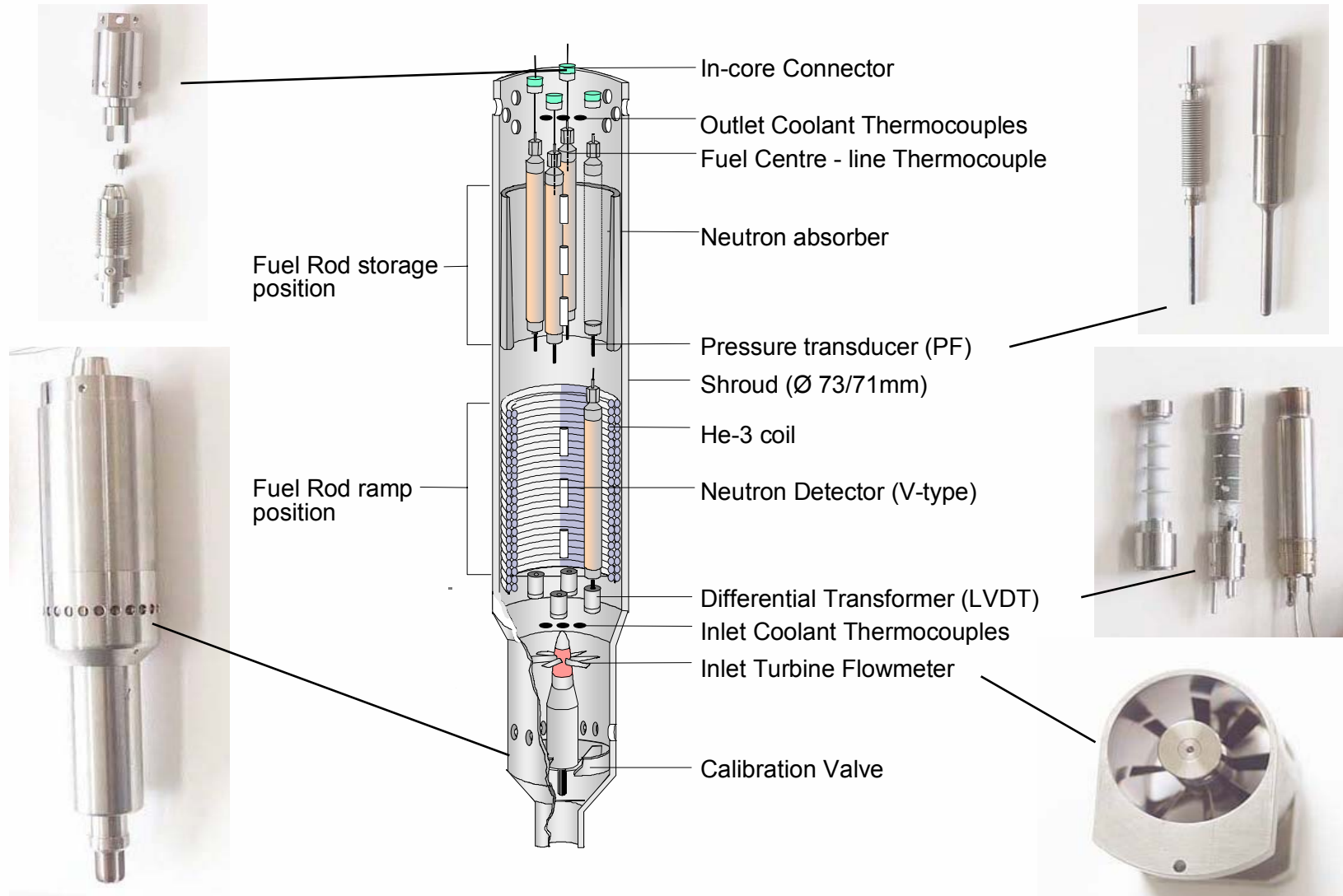

Fuel rod instrumentation

Relevant to fuel performance



Validation of models

Thermocouples

- Fuel T
- Cladding T

LVDT principle

- Temperature
- Elongation
 - fuel stack elongation
 - cladding elongation
- Pressure (fission gas)

Gas Lines

- Adjust rod pressure (e.g. overpressure)
- Fuel-clad gap
 - hydraulic diameter (swelling)
 - gap conductance (change gas mixture)
- Radioactive fission gas release



Fuel temperature

With fuel thermocouples, fuel centreline temperatures can be measured accurately and reliably for temperatures up to ~1500 - 1600°C.

For short-term measurements (hours) temperatures even as high as ~2000 °C have been measured without thermocouple failure.

Fuel centreline thermocouples (TF) enable modellers to compare their code predictions with measurements:

- **Gap conductance**
 - Gap width
 - Surface roughness
 - Eccentricity
 - Gas composition (FISSION GAS RELEASE)
- **Pellet**
 - Densification and swelling (indirect)
 - Thermal conductivity (degradation)



Variation of gap size

The gap between fuel and cladding is a design parameter and in addition changes with exposure. Numerous HRP experiments provide an extensive data base for assessing the basic influence of gap size on gap conductance. The general trend is summarised in the graph on the right for Helium and Xenon as fill gas.

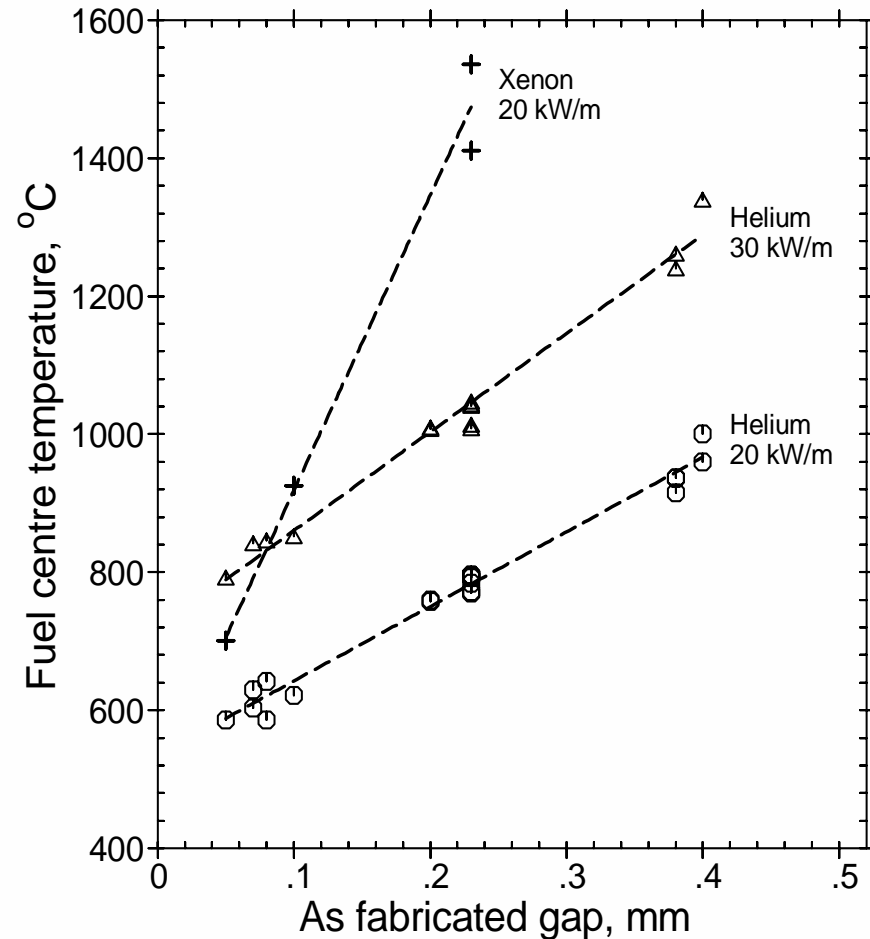

Influence of gap on fuel temperature

Variation of surface roughness

Surface roughness is a parameter in gap conductance models (effective gap width, contact conductance). The parameter was investigated in IFA-562.1. Although an effect could be identified, it was not as clear and pronounced as predicted. (HWR-245)

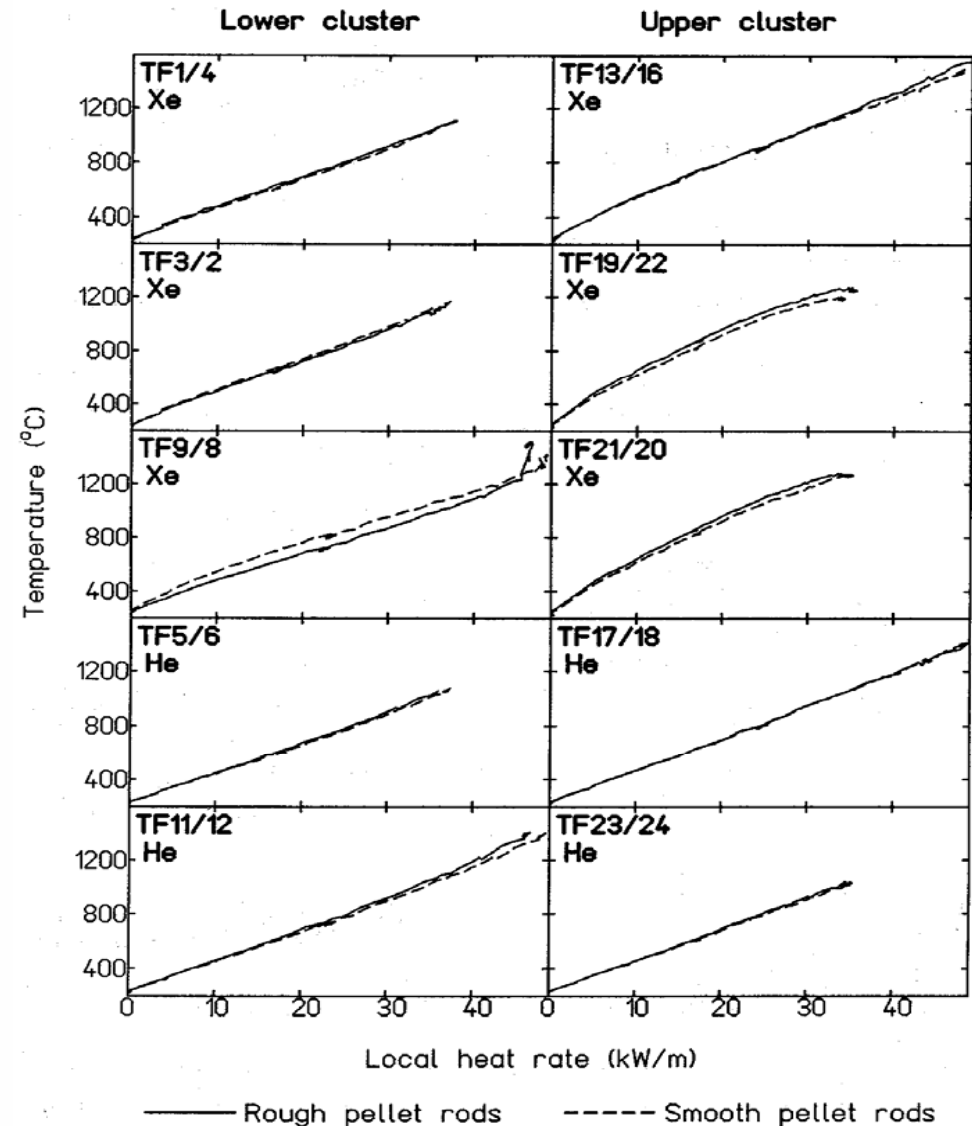

Assessment of pellet eccentricity

Fuel pellets assume an eccentric position in the cladding tube. The unsymmetric heat transfer should lead to overall lower average fuel temperatures compared to the ideal concentric case. The effect was investigated in IFA-431 and IFA-432. The data provide some corroboration of the expected outcome.

The nonlinear relation of temperature vs. power is typical of Xe or fission gas filled rods.

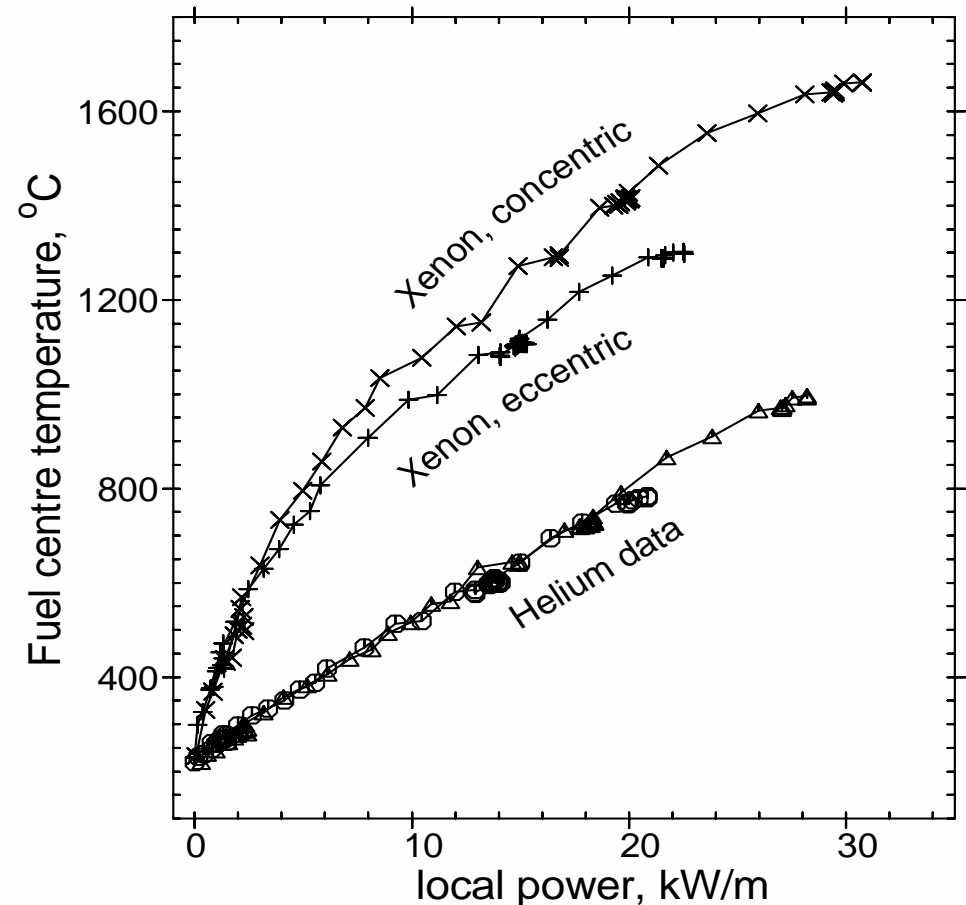

Effect of eccentric pellets on temperature

Fill gas type and composition

The initial fuel rod helium fill gas is diluted by released fission gas resulting in decreased gap conductance. The effect and the feedback on temperatures and further gas release needs accurate modelling. A number of experiments were conducted in the past where xenon or argon were added to simulate various degrees of fission gas release. The results from several IFAs are summarised in the figure.

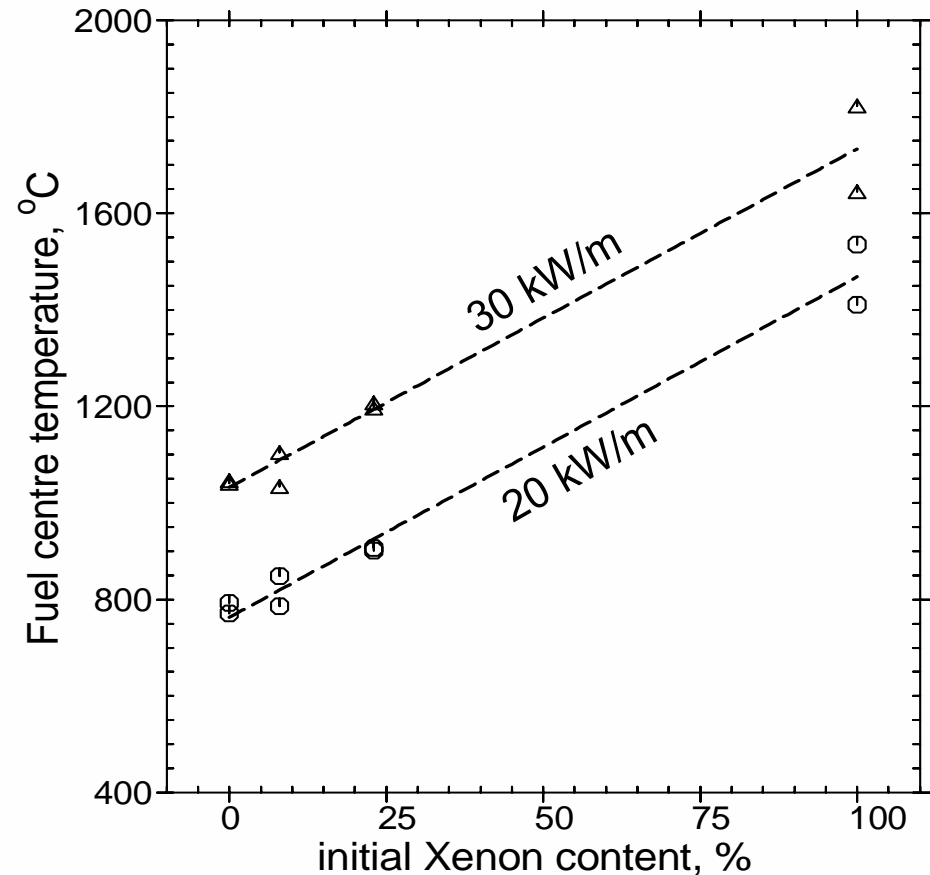

Influence of fill gas on fuel temperature

Linear Voltage Differential Transformer (LVDT)

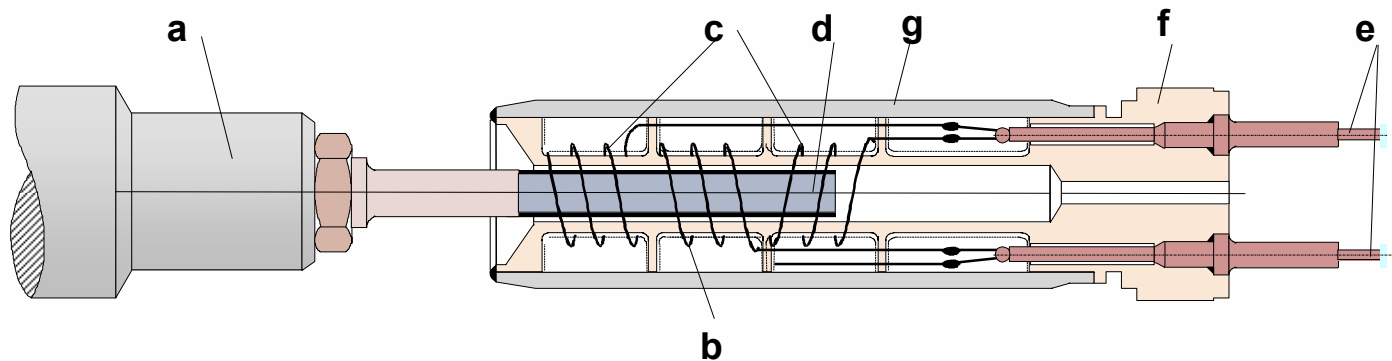

- a: Test rod end plug assembly
- b: Primary coil
- c: Secondary coils
- d: Ferritic core
- e: Twin-lead signal cables
- f: Body
- g: Housing

- Measuring fuel rod pressure, fuel temperature, fuel stack elongation and cladding elongation
- Primary coil with two secondary coils connected in opposition. Movable magnetic core concentrically located inside coil system.
- Core movement affects the balance of the secondary coils and generates the signal output.
- Normally fixed to the rig structure – not part of the fuel rod

Linear Voltage Differential Transformer (LVDT)

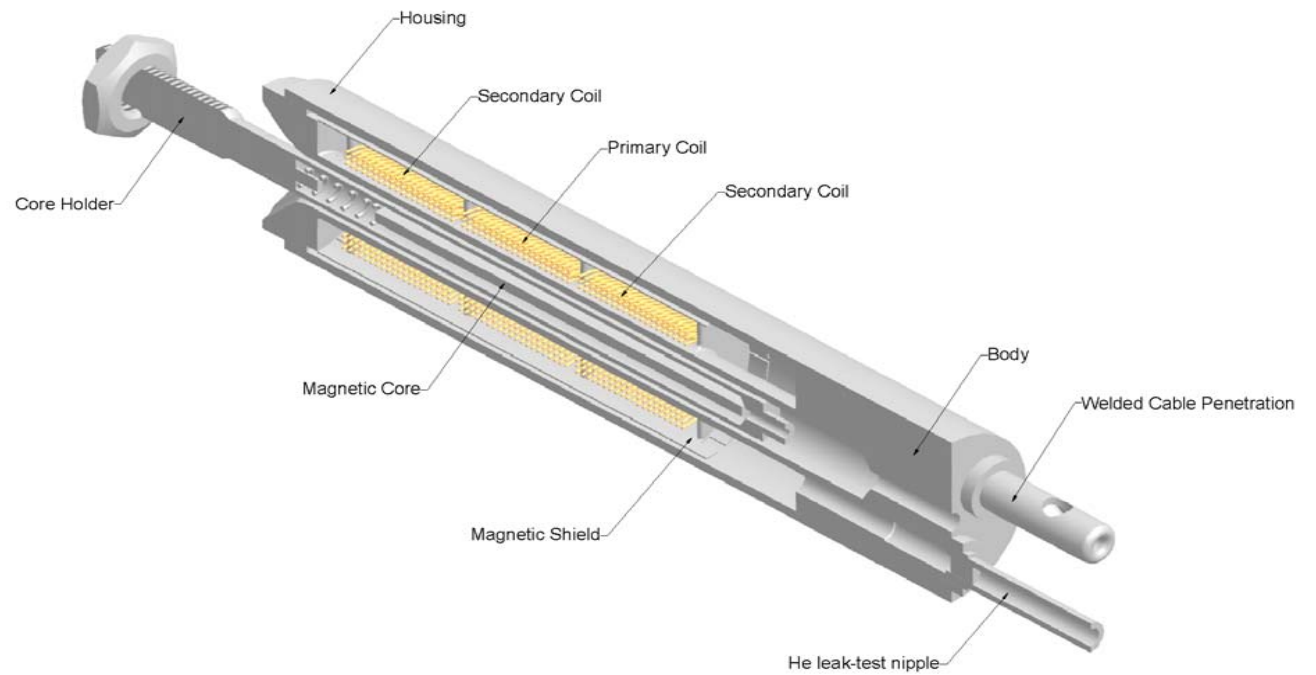

Expansion Thermometer

- Alternative to Fuel Thermocouple.
- Provides data on fuel rod *average* centre-line temperature.
- Magnetic core fixed to a tiny refractory metal rod penetrating the centre-line of the whole fuel stack. Core movement is sensed by the LVDT.

Advantages:

- Recommended for high-temperature measurements.
- No decalibration with time.
- Can move rod between rigs (e.g. base irr. → ramp rig)

Disadvantages:

- No solid pellets - → lower centre T (may be important for FGR studies)
- May get sticking at high BU (fuel swelling)

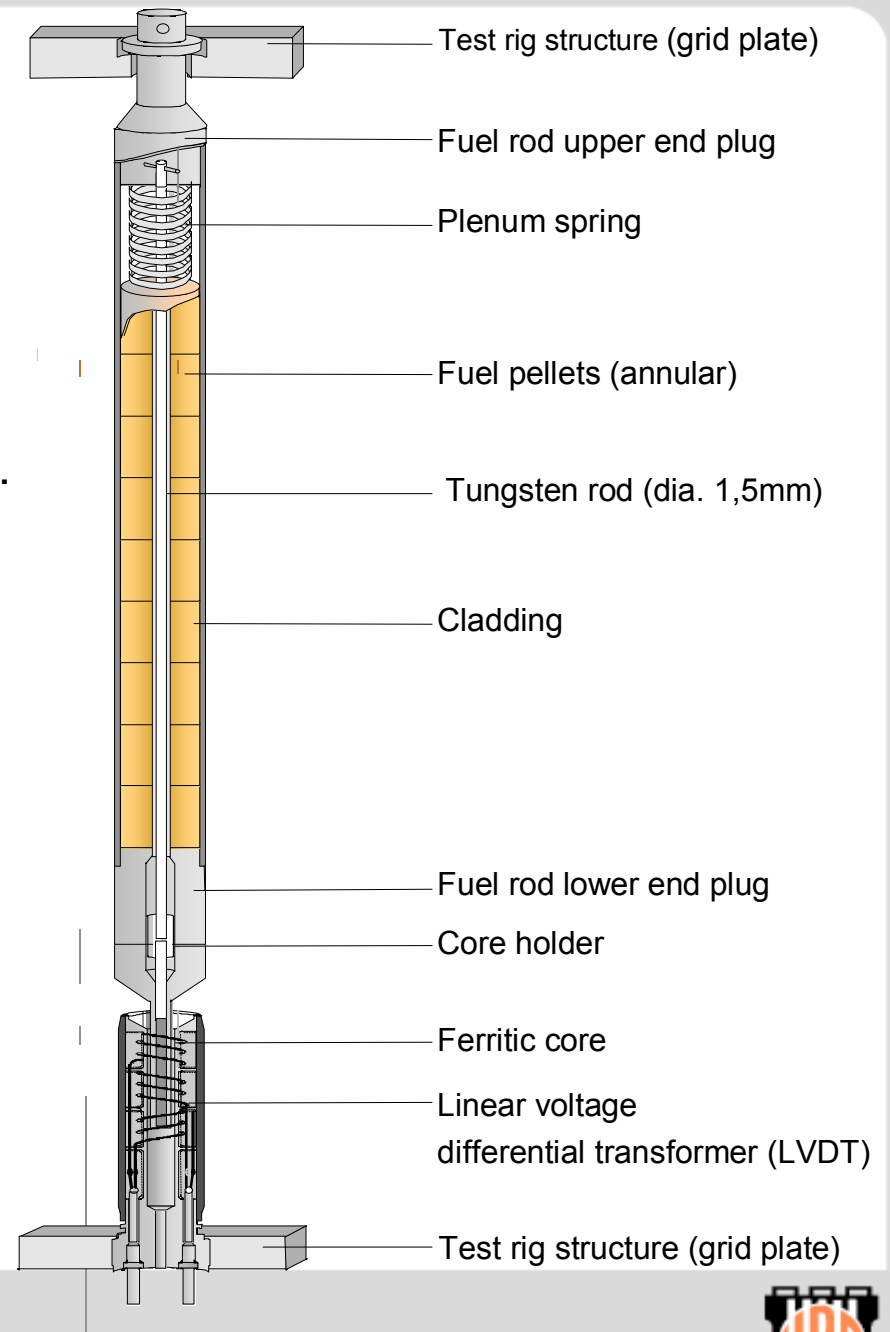

Expansion Thermometer

Thermal Conductivity Derived from in-pile Fuel Temperature Data

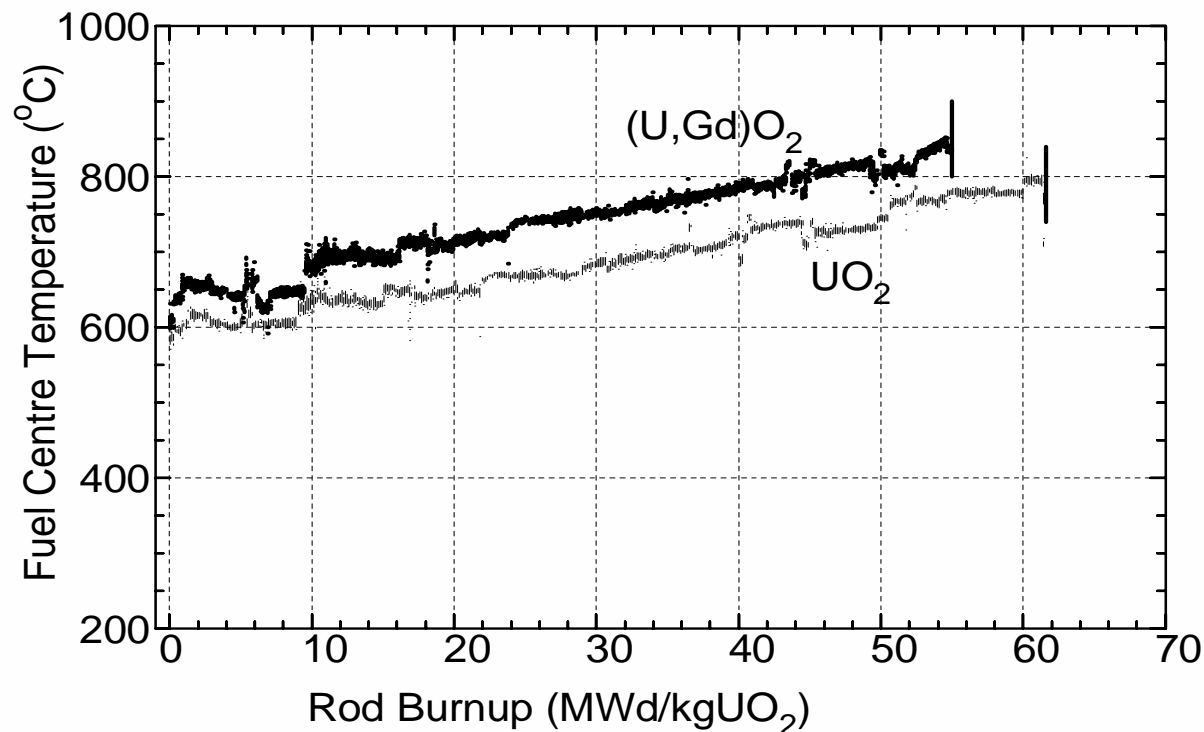

- Fuel centre-line temperature linked to thermal conductivity
- Halden has a large database from numerous fuel rods that have been equipped with thermocouples or expansion thermometers
- Database includes different fuel types (UO₂, MOX, Gd-fuel, IMF)

This comparative irradiation shows conductivity difference of two types of fuel as well as the change of conductivity with burn-up

UO₂ Thermal Conductivity Derived from In-pile Fuel Temperature Data

- Large data base from low to >65 MWd/kg burnup
- Direct link to quantity of interest (fuel temperature)
- Includes influence of :
 - Fission products in matrix
 - Micro-cracking
 - Frenkel defects
 - Fission gas bubble formation
- Can be applied locally

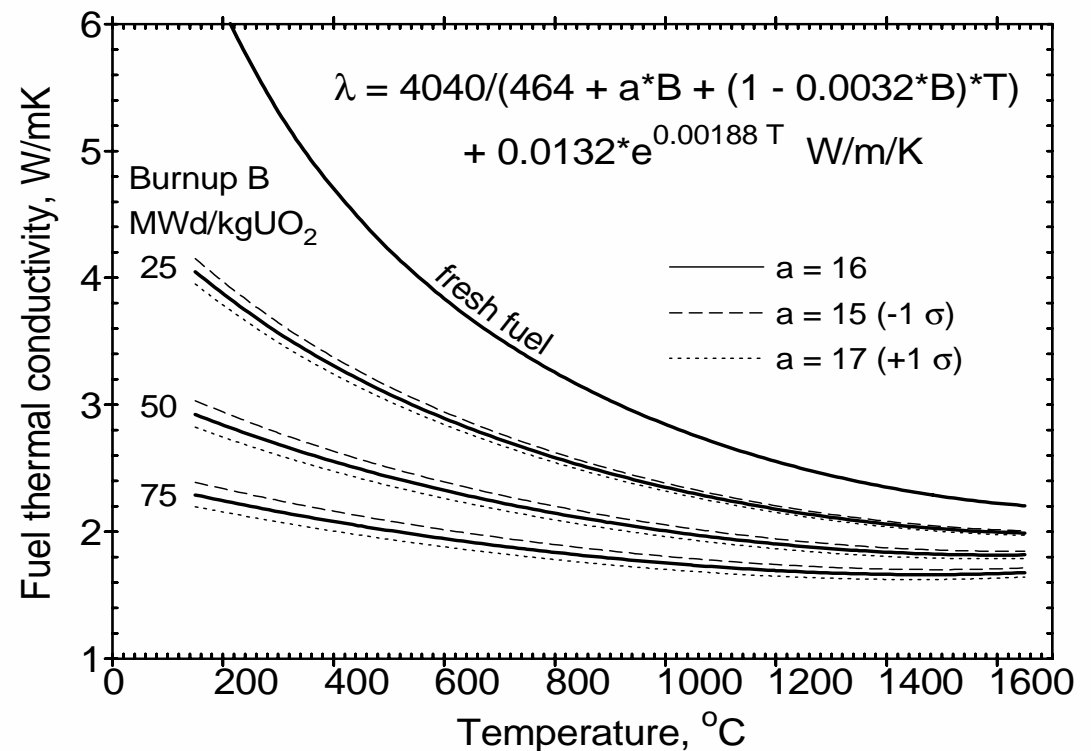

Fuel Stack Elongation Detector (EF)

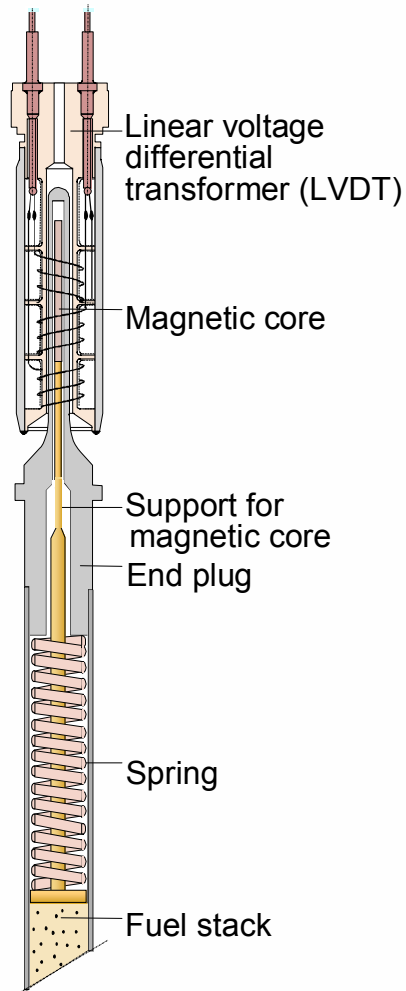

- Provides densification and swelling data in terms of axial expansion of the fuel stack.
- Magnetic core spring loaded against the fuel column end pellet in the rod plenum.
- Core movement measured by LVDT.

Fuel Stack Elongation Detector (EF)

PELLET STACK ELONGATION VS. LHGR EARLY-IN-LIFE

Dished pellet

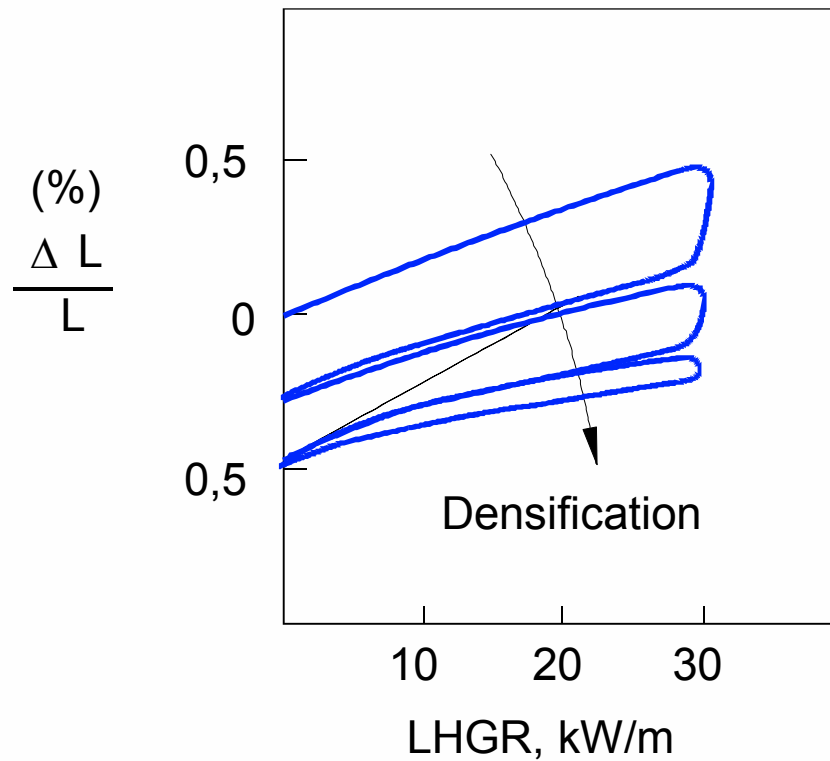

Flat pellets

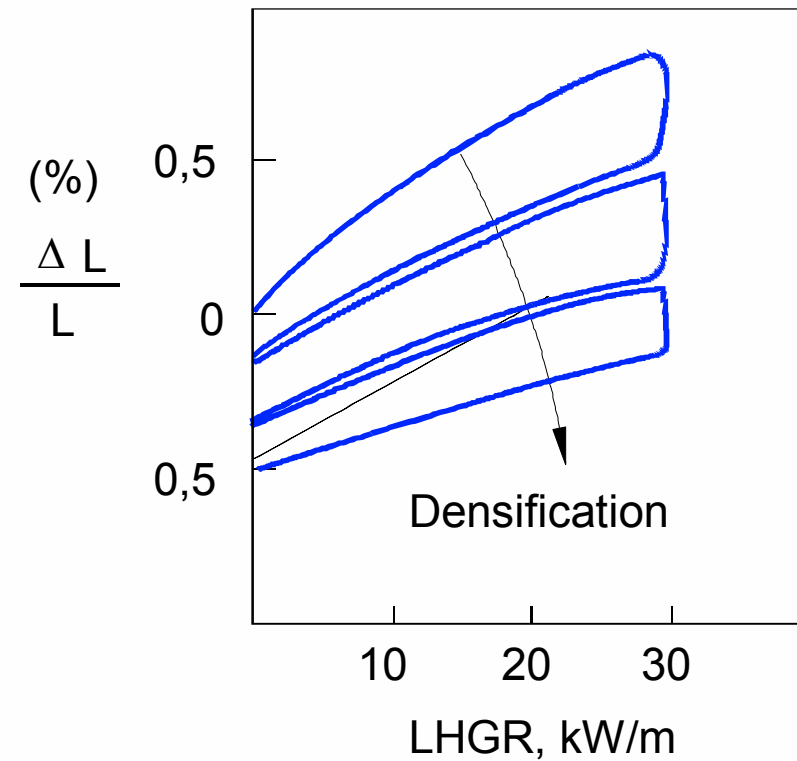

Fuel Stack Elongation Detector (EF)

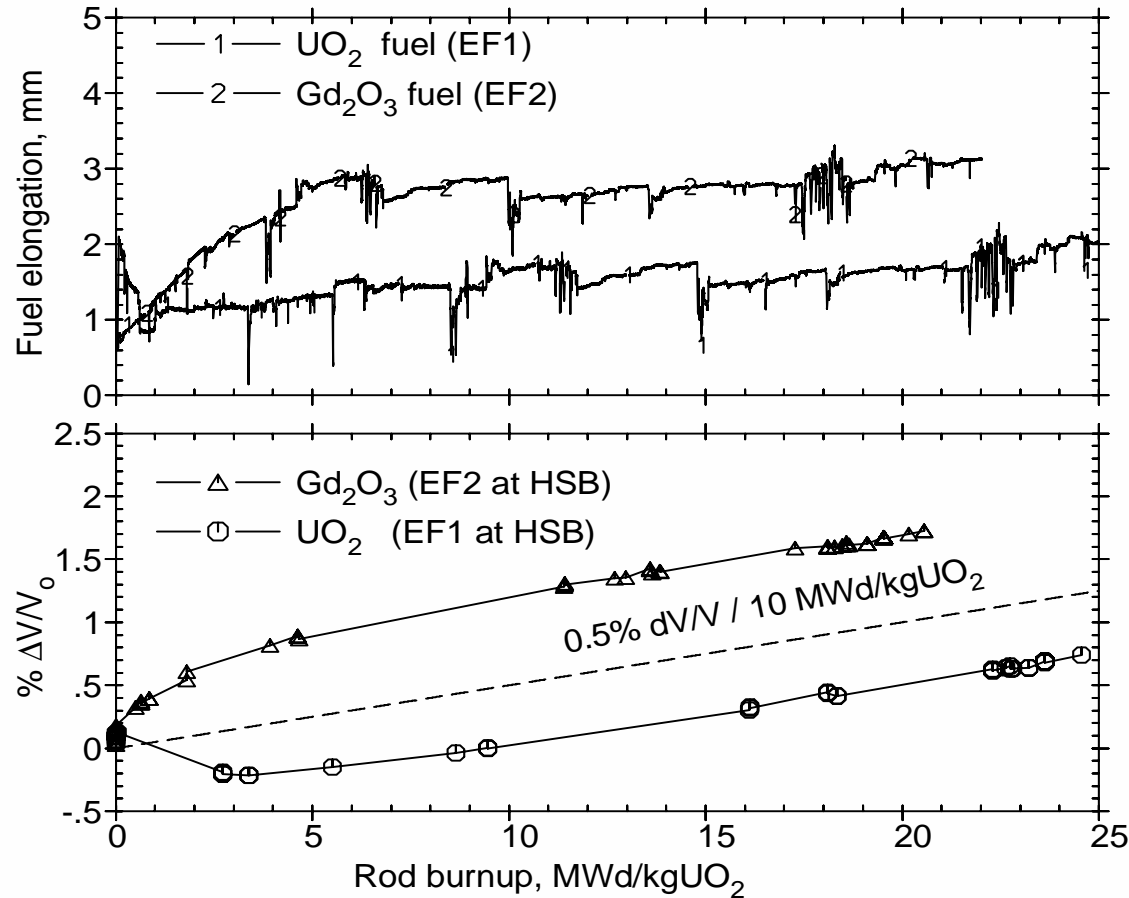

*Swelling of UO₂ and Gd-UO₂ fuel
derived from fuel stack length change*

Swelling and densification

- Irradiation of production line UO₂ and Gd-UO₂ fuel, 8 w/o gadolinia
- No densification is observed for Gd-UO₂ fuel
- Both fuel types show a swelling rate of about 0.5% $\Delta V/V$



Cladding Extensometer (EC)

- Provides data on pellet-cladding interaction (PCMI) and axial deformation of the cladding.
- Movement of a magnetic core (fixed to the fuel rod end) measured by a LVDT.
- Can also be used as a point of dry-out detector or for measuring oxide layer and crud build-up (assumes no PCMI).

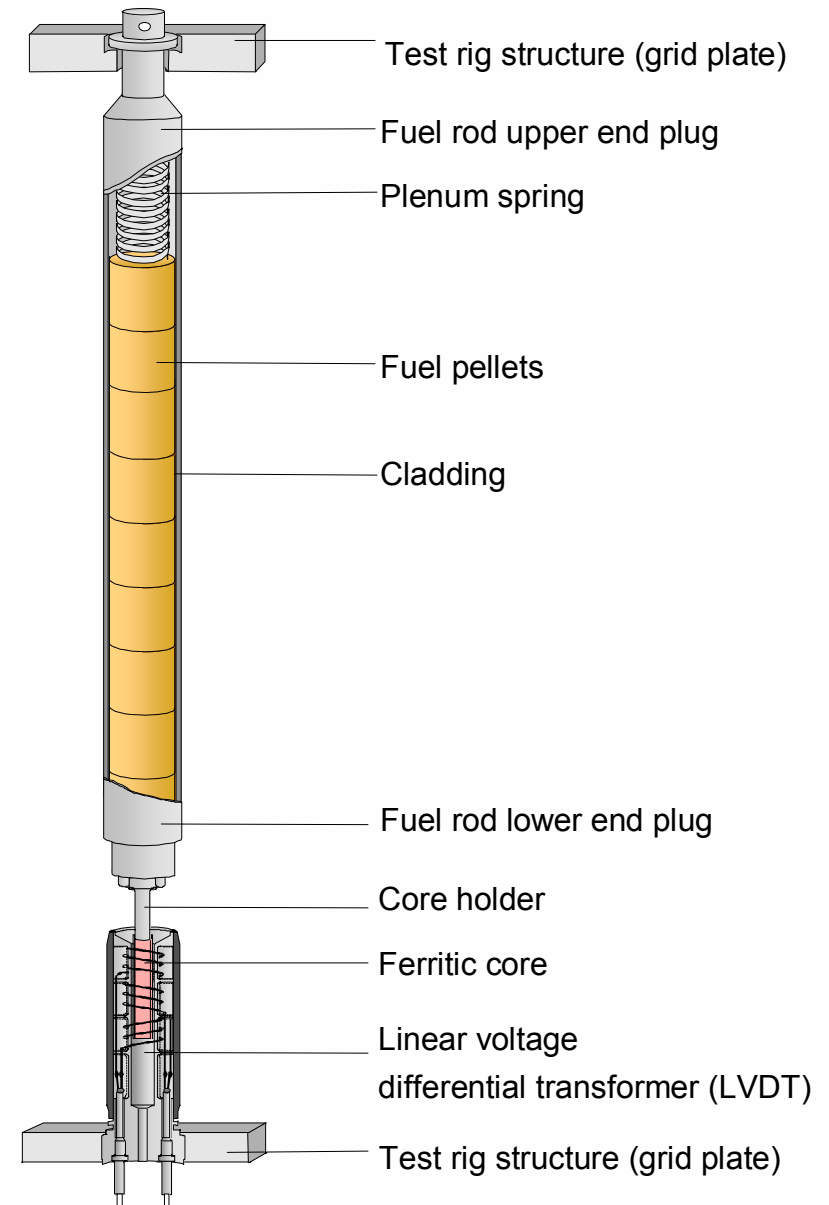

Possibilities to Measure PCMI and Fuel Stack Properties

- Primary measurements
 - Diameter gauge, 3-point feeler moving along the length of the rod, μm sens.
 - Cladding elongation sensor, LVDT principle, frequent measurements, reliable
- Secondary measurements
 - Gas flow, hydraulic diameter
 - Noise analysis (elongation and neutron detector)

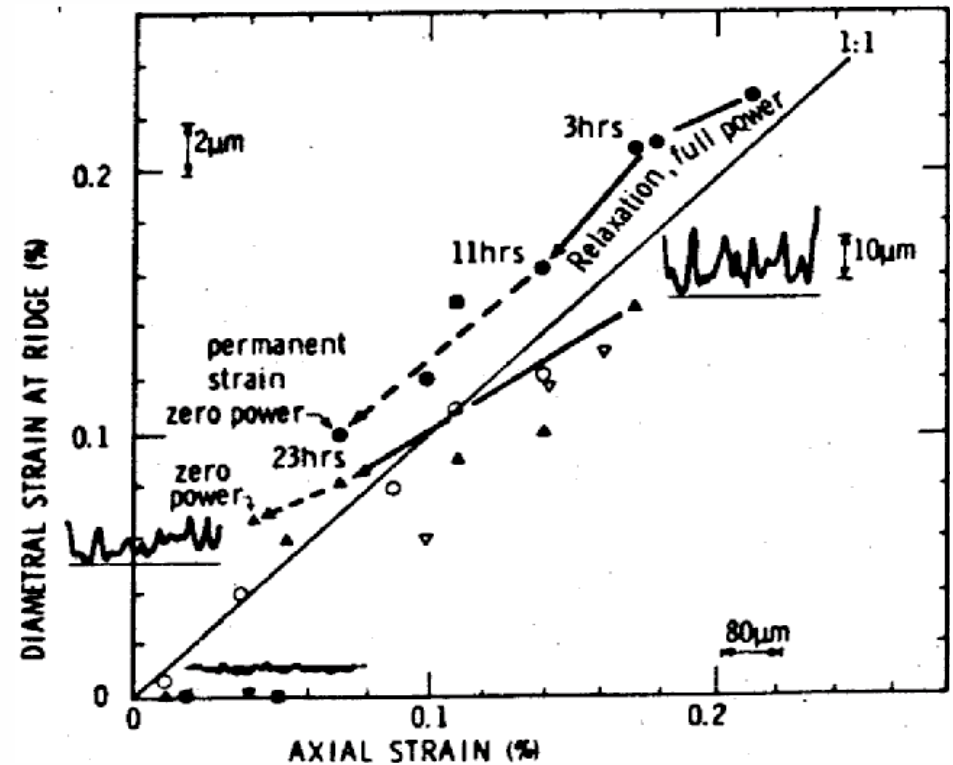

Axial and diametral deformation show similar trends

Development of Onset of Interaction – Fresh Fuel –

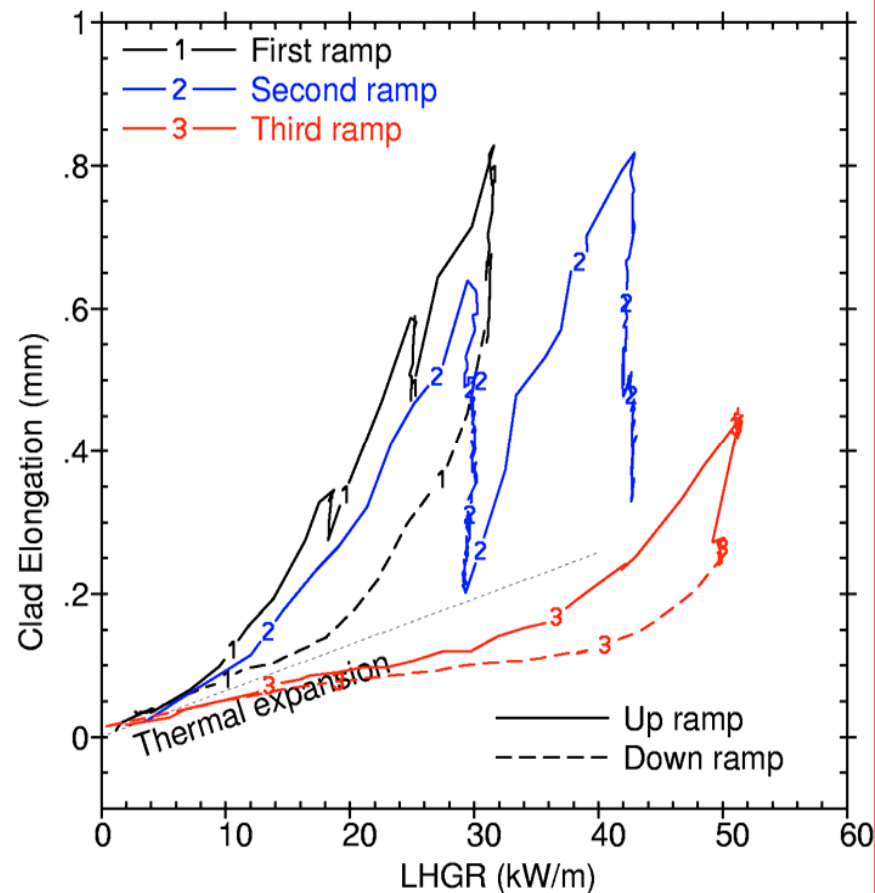

Features of early-in-life PCMI

- First power ramp: very early onset of interaction
- Following power ramps: shift of PCMI onset to higher power
- Relaxation of axial strain during power holds
- Immediate continuation of elongation when power increases (strong contact)

Development of Onset of Interaction – Low to Medium Burnup –

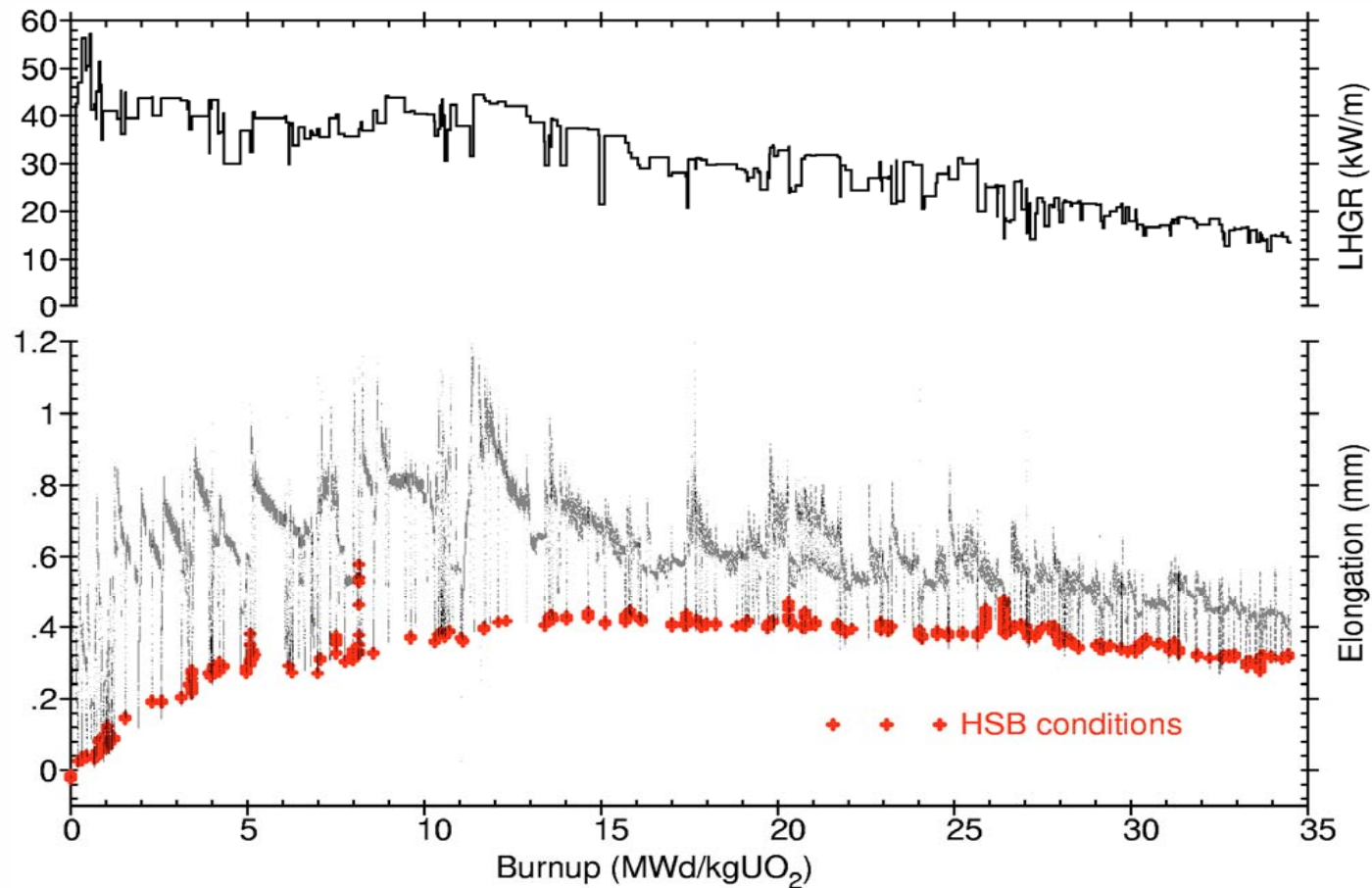

Development of Onset of interaction Fuel-clad accommodation

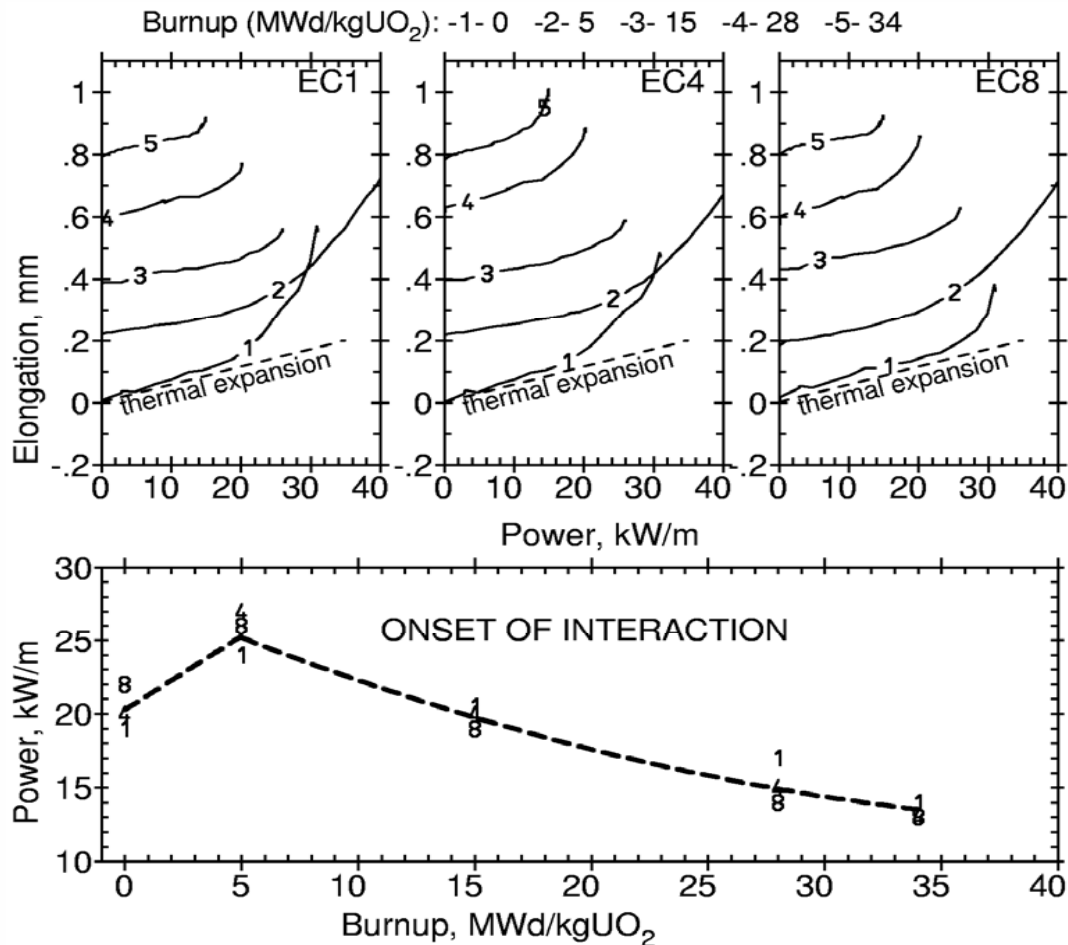

- The onset of interaction moves to lower power with increasing burnup and decreasing power
- The accommodation of fuel and cladding to each other result in small 'interaction tails' as long as power does not exceed previously reached levels.



Cladding temperature

Measurement of the cladding temperature is normally not within the scope of the HRP experimental programme. However, if PCMI can be eliminated, details of cladding elongation behaviour can be used to qualify

- Coolant-clad heat transfer coefficient (Jens-Lottes not satisfactory for low power)
- Zry-oxide conductivity

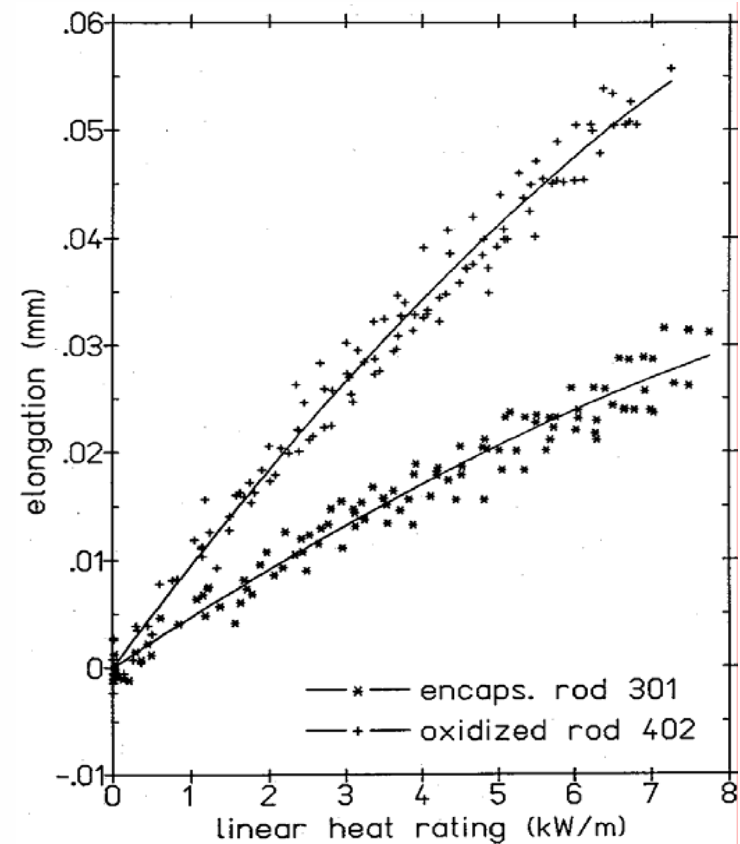

Elongation of cladding with and without outer oxide layer (IFA-597)

Gas flow lines: Hydraulic diameter measurements

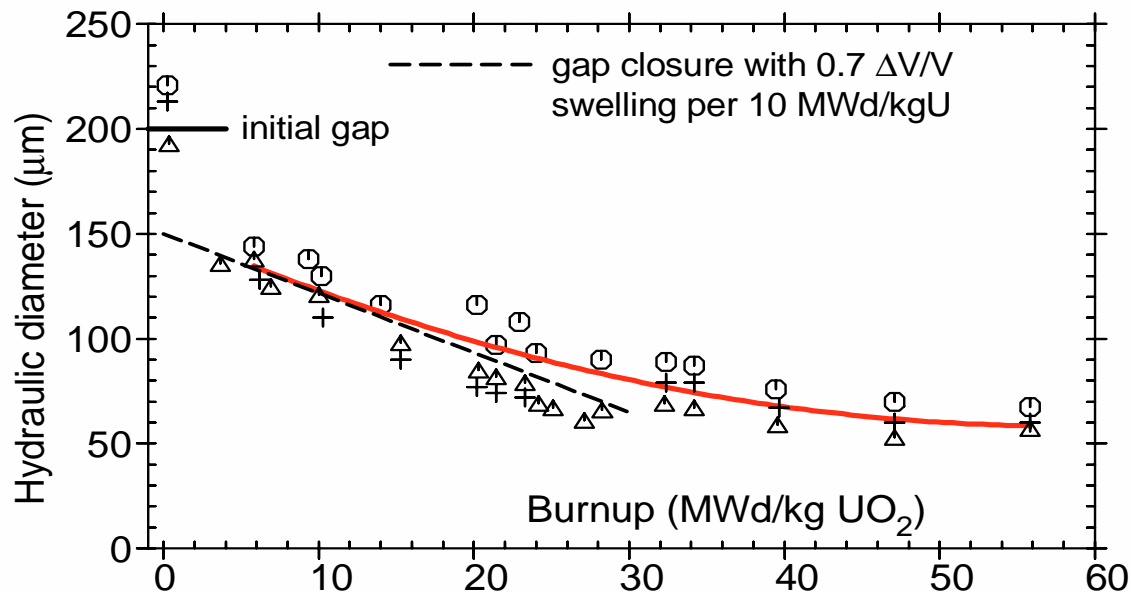

*Change of hydraulic diameter
(free fuel column volume)*

- The hydraulic diameter reflects the free volume in the fuel column. Normal changes are:
- initial pellet cracking and fragment relocation
 - solid fission product fuel swelling
 - development of a minimal HD as fuel and cladding accommodate to each other

Pressure Transducer (PF)

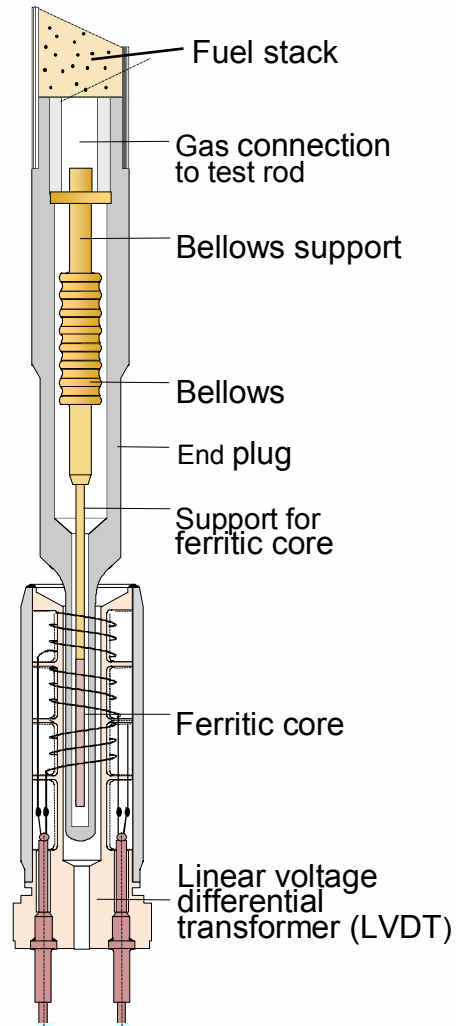

- Provides data on fission gas release (or fuel volume change) by means of measurements of the fuel rod inner pressure.
- Miniaturised bellows with access to the fuel rod plenum mechanically fixed in the fuel rod end plug.
- Magnetic core fixed to the free moving end of the bellows. Core movement sensed by LVDT.
- Pre-conditioned and pre-pressurised bellows in order to reduce creep due to high temperatures and radiation.
- Bellows types: Range 15, 30 or 70 bar ΔP
- Often used in conjunction with fuel temperature measurements (TF)

Fill gas pressure, extrapolation length

- Gap conductance models employ the concept of 'extrapolation length' to account for imperfect heat transfer between gas and solid
- The correction depends on pressure
- The effect has been assessed experimentally
- It shows some burnup dependence, possibly due to changes in number of fuel cracks

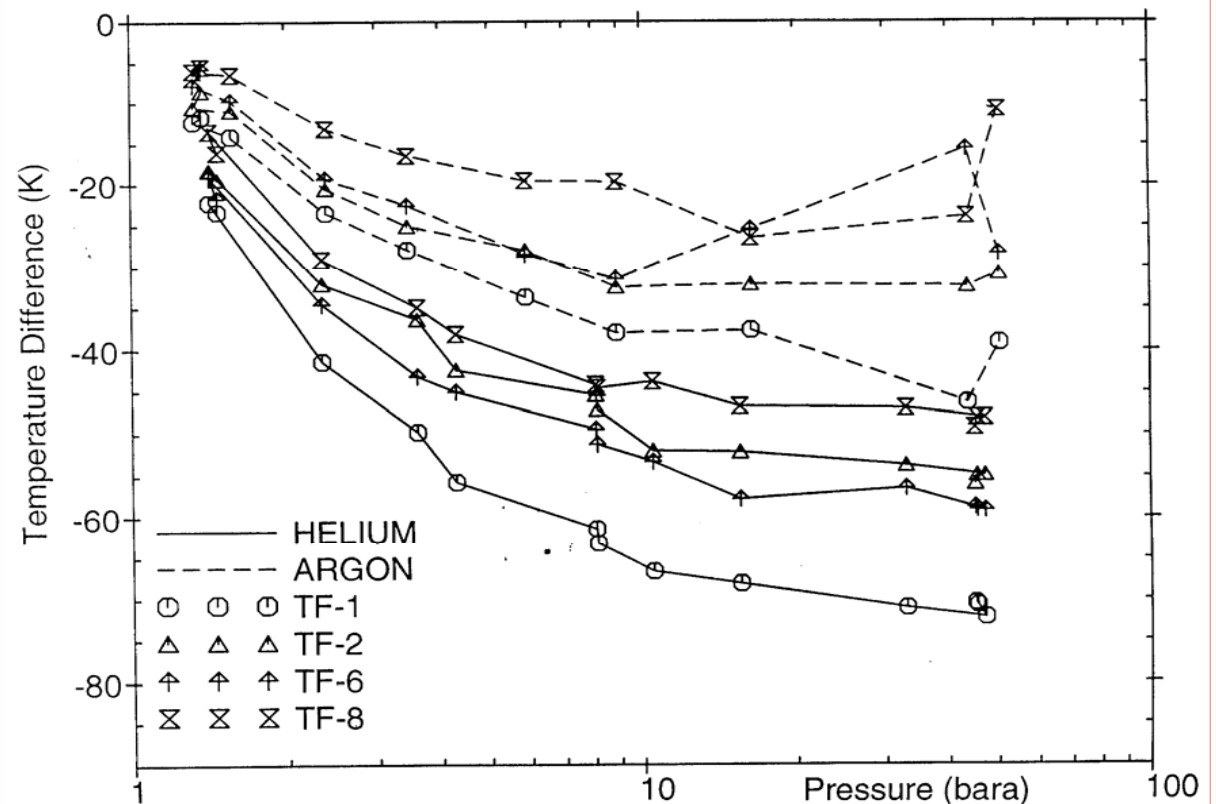

Other instruments

Flow meter

- Power calibration



Pick-up coil



In-core contacts

- Re-instrumentated rods (TF)
- Rods re-mountable
 - Rig re-usable



- Water level gauge

➤ based on floater with inductive position measurement

Re-instrumentation of irradiated fuel rods

Test rig for re-instrumented fuel rods

Fuel assembly irradiated in a commercial LWR

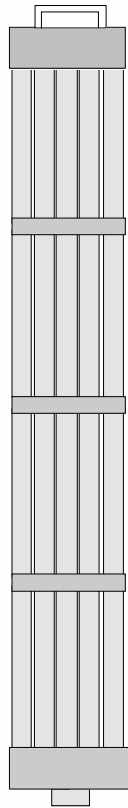

Fuel rod segment

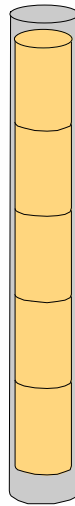

Re-instrumented fuel rod segment with Fuel thermocouple and Pressure transducer

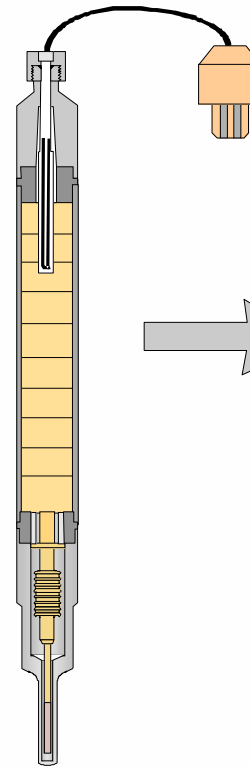

Re-irradiation in LWR-Loop

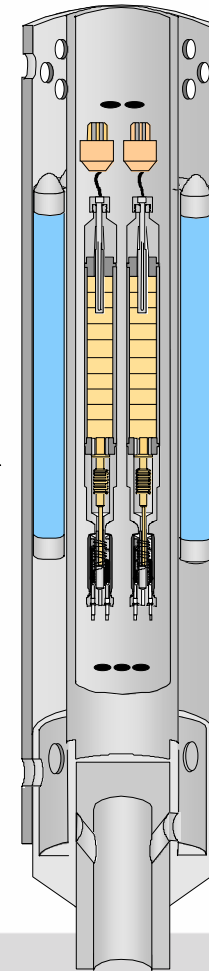

Re-instrumentation of irradiated fuel rods

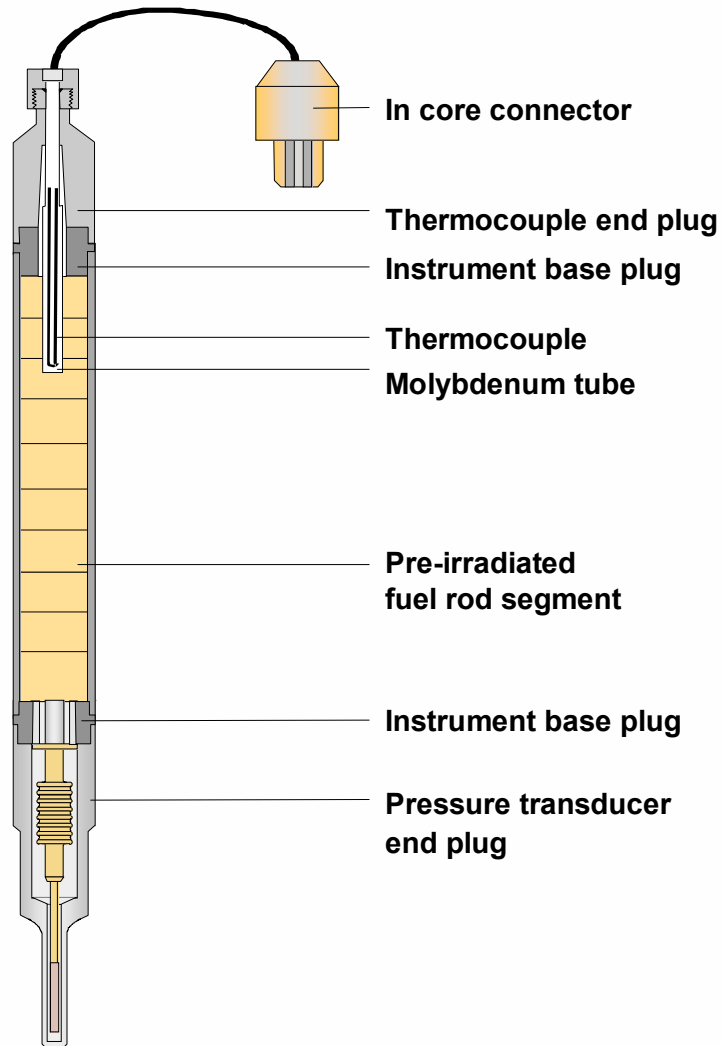

- Fuel segments taken from commercial LWRs
- Medium and high burnup
- Re-instrumentation at Kjeller hot-lab facilities
- Instrumentation possibilities:
 - fuel thermocouple (TF)
 - rod pressure sensor (PF)
 - cladding elongation sensor (EC)
 - cladding thermocouple (TCC) (LOCA or dry-out studies)
 - gas flow lines
- First re-instrumentation in 1991
- >130 rods re-instrumented since then

Re-instrumentation of irradiated fuel rods

Neutron radiography after drilling of TF hole

- Verification of the alignment of the TF in the drilled centerline hole
- Determination of the exact location of the TF hot junction

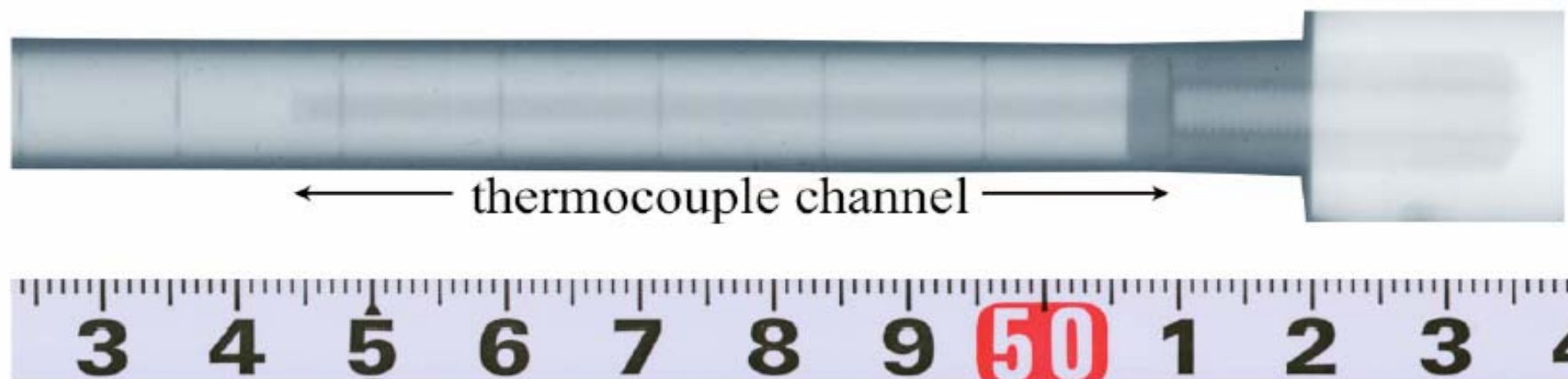

Re-instrumentation of irradiated fuel rods

High Burnup Fuel Structure

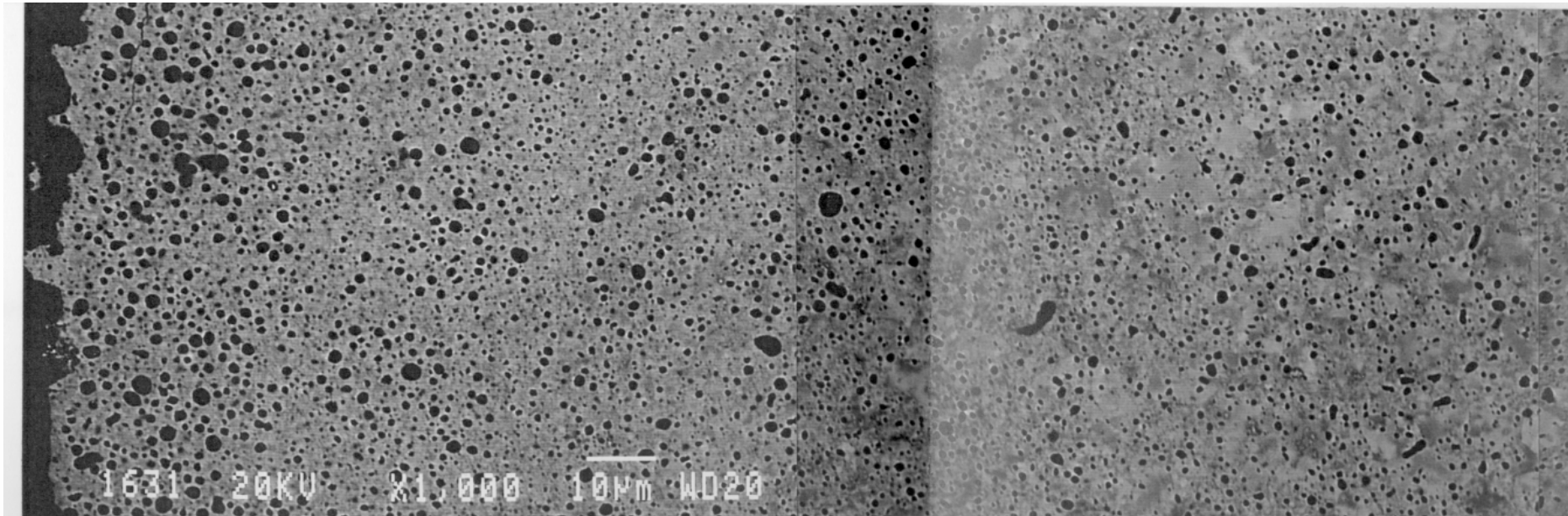

SEM image of periphery region of high burnup fuel pellet (59 MWd/kgUO₂)

The fuel has undergone considerable changes in the peripheral region:

- Loss of defined grains up to 100 µm into the fuel
- Development of spherical porosity reaching about 500 µm into the fuel
- Bonding layer between fuel and cladding

Re-instrumentation of irradiated fuel rods

Thermal behaviour of high burnup fuel

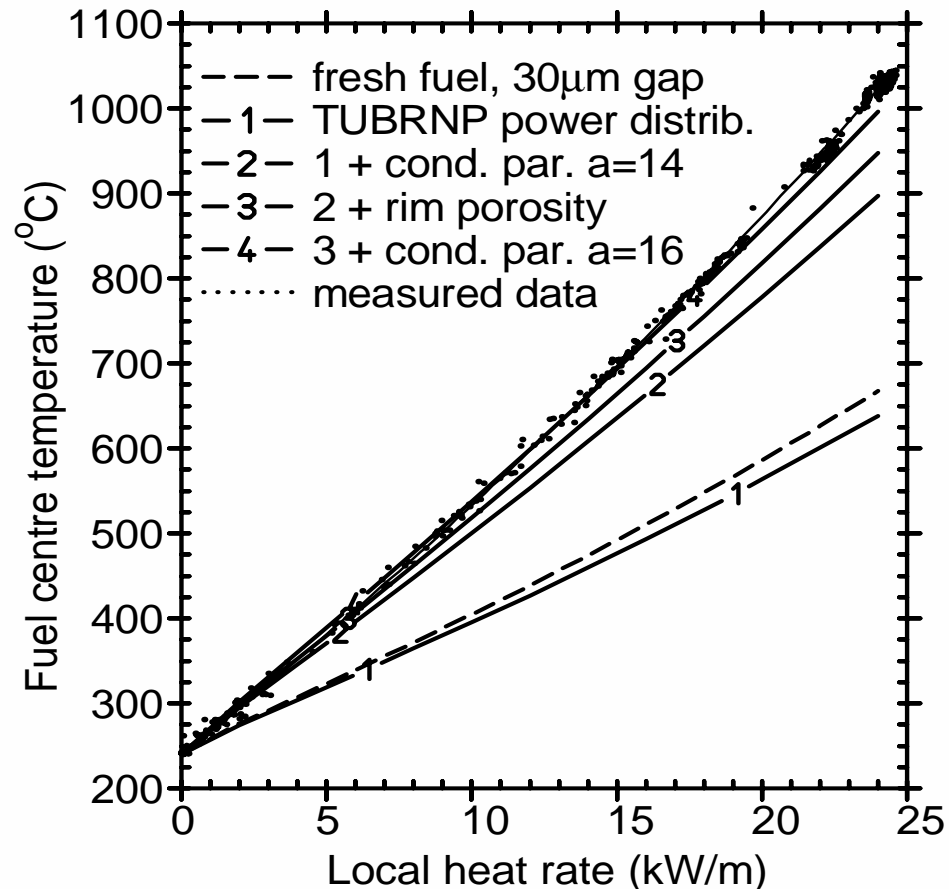

- High BU (59 MWd/kgUO₂) UO₂ rod re-instrumented with TF and PF
- Appreciable difference to temperatures of fresh fuel
- Important factors:
 - conductivity degradation
 - power distribution
 - rim porosity
- The model for UO₂ conductivity degradation derived from other in-pile temperature data is suitable for explaining the differences

Re-instrumentation of irradiated fuel rods

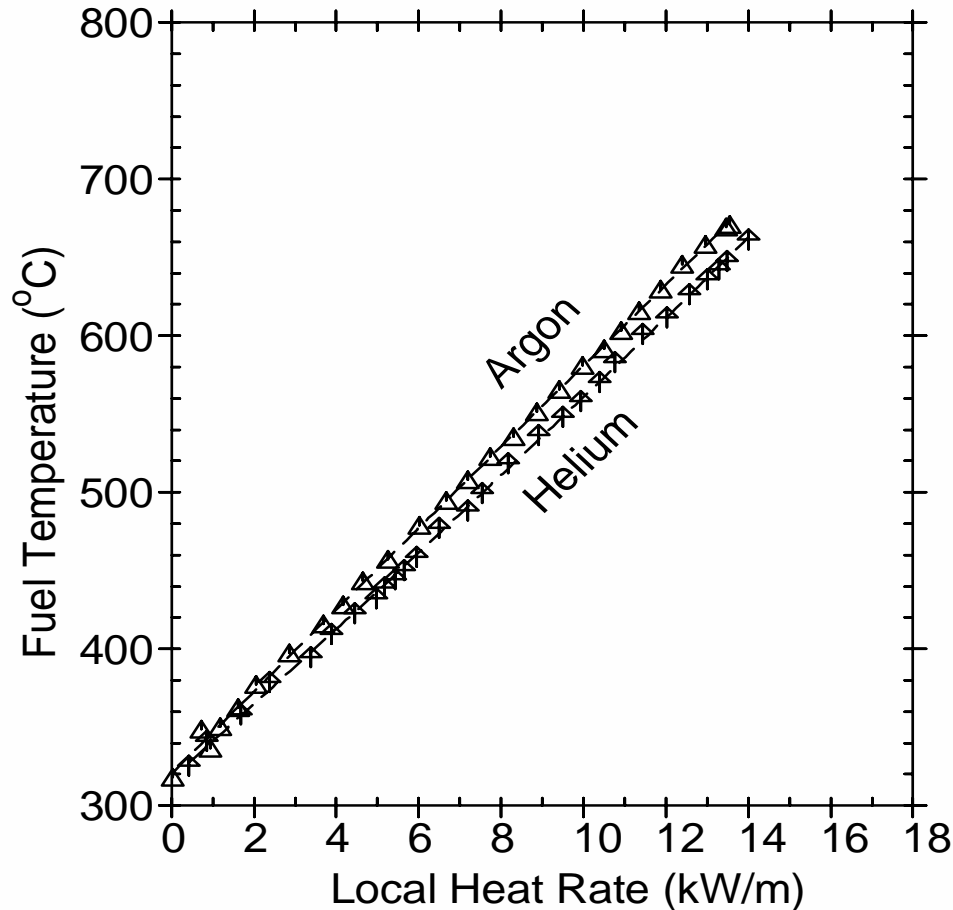

Temperature response to fill gas change (He <> Ar), IFA-610

Gap conductance, high burnup fuel

Experimental rigs with gas lines provide for a change of fill gas during in-core service. This feature allows to assess the dependence of gap conductance on fill gas composition. For high burnup fuel, the temperature response to fill gas change (Ar < > He) is small.

A similar behaviour is seen when a burst release of fission gas occurs during a power decrease. This is the consequence of the tightly closed fuel - clad gap.



Re-instrumented PWR fuel:

PCMI: Initial

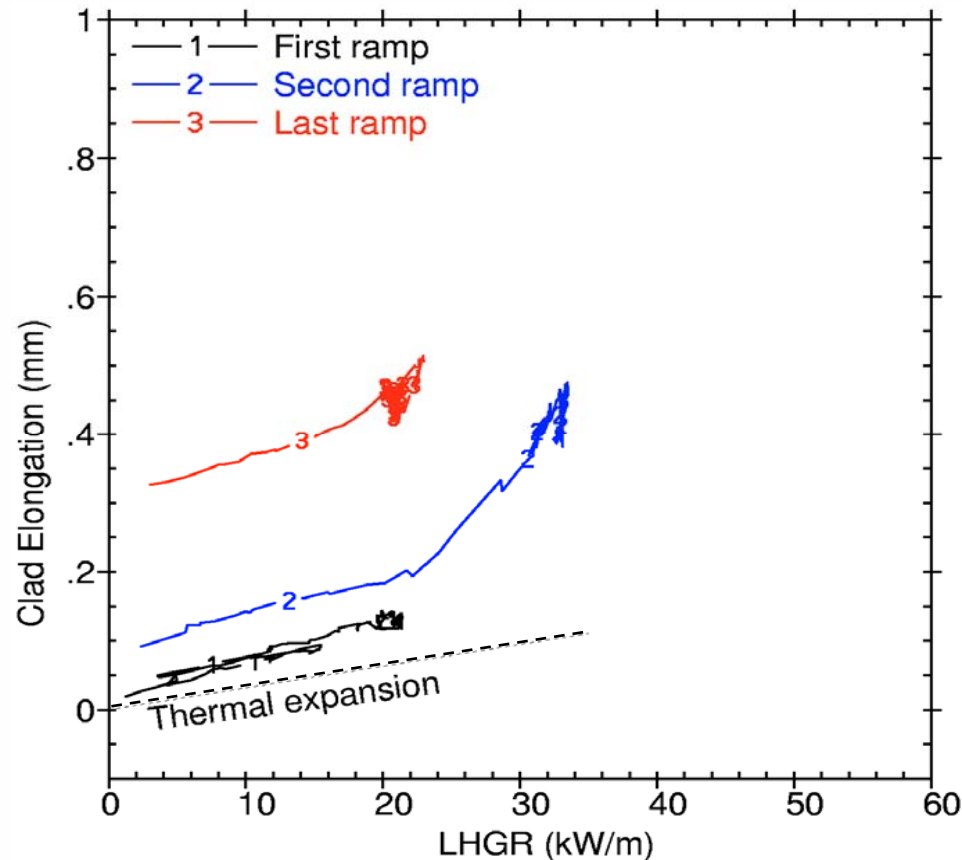

- PWR UO_2 fuel (52 MWd/kg UO_2)
- Re-instrumented with EC
- No appreciable PCMI for the first ramp since the conditioning power of 20 kW/m is not exceeded
- Linear elongation part is more than calculated for thermal expansion
- Some re-conditioning during 2.5 MWd/kg burnup increment between second and last ramp



Re-instrumented PWR fuel:

PCMI: Axial ratcheting

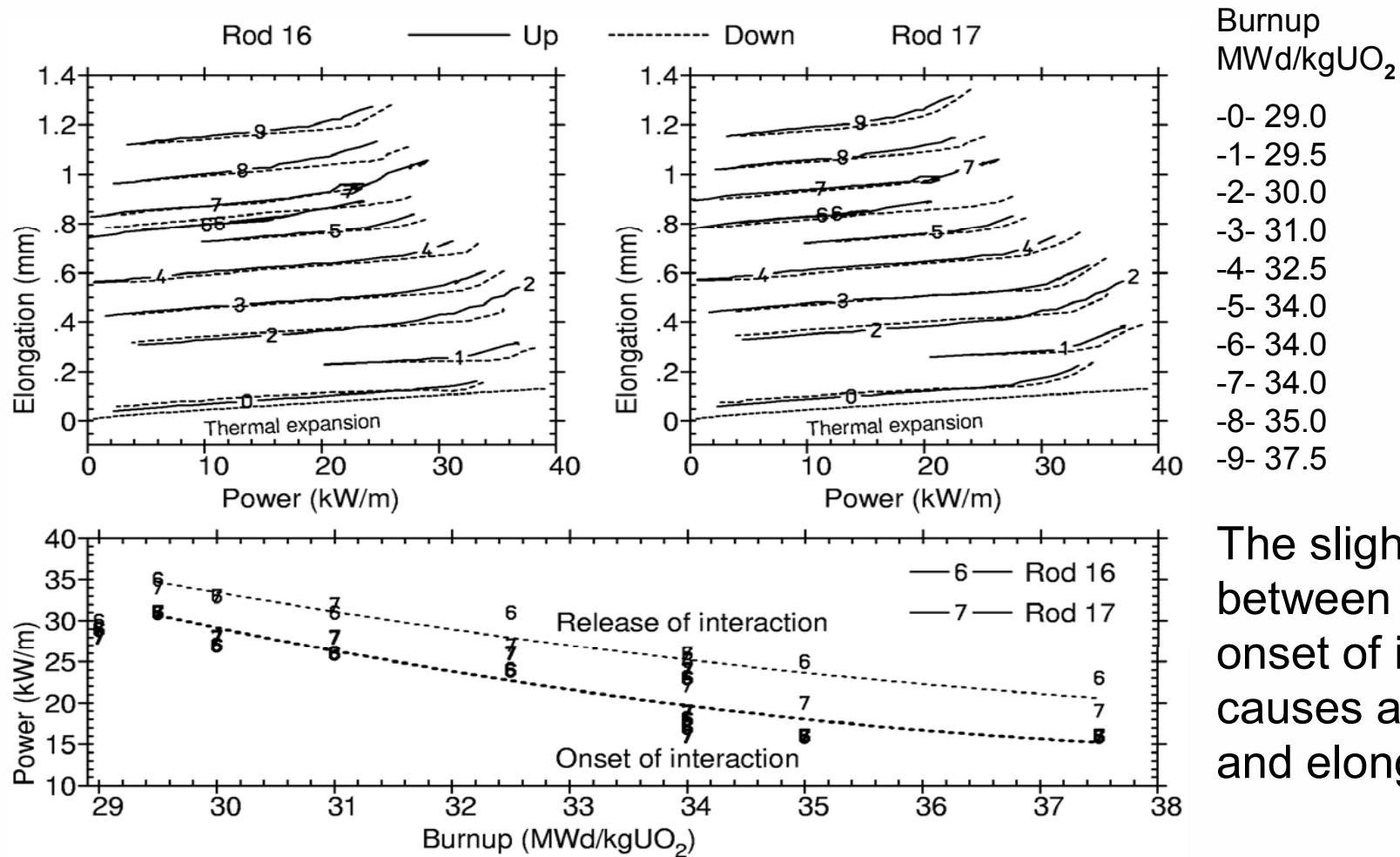

Burnup
MWd/kgUO₂

- 0- 29.0
- 1- 29.5
- 2- 30.0
- 3- 31.0
- 4- 32.5
- 5- 34.0
- 6- 34.0
- 7- 34.0
- 8- 35.0
- 9- 37.5

The slight mismatch between release and onset of interaction causes axial ratcheting and elongation peaks



Re-instrumented PWR fuel:

PCMI behaviour at high burnup (UO_2)

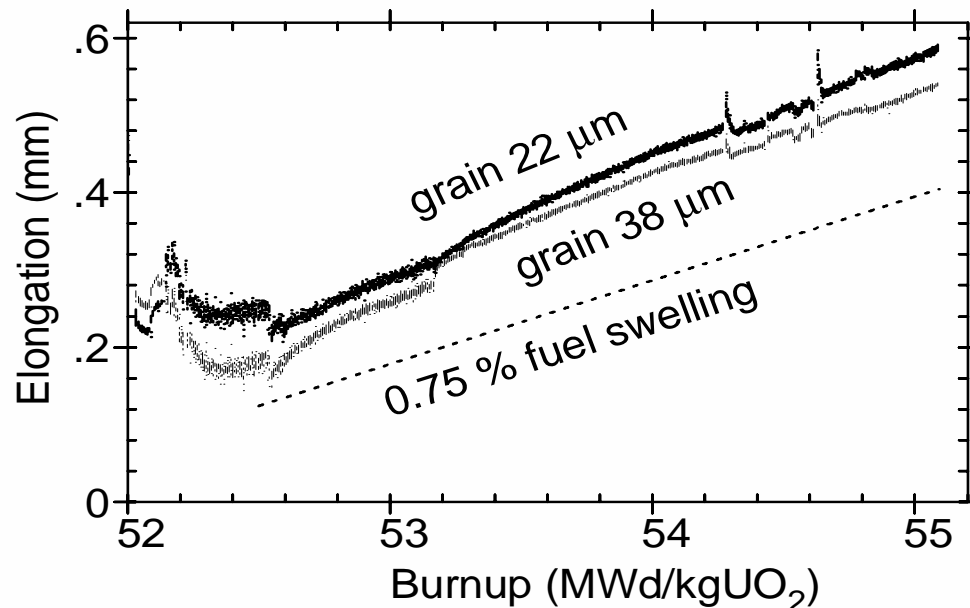

Cladding elongation response of re-instrumented PWR fuel (61 MWd/kgU) with different grain size during steady state periods.

- **Permanent elongation**
Clad elongation increase reflects fuel swelling
- **Ratcheting**
Elongation peaks associated with shut-down / start-up (release/onset mismatch)
- **Relaxation**
Initial relaxation of high power elongation. Stress caused by ratcheting is relaxed by fuel creep within a few days

Re-instrumented PWR fuel:

PCMI behaviour at high burnup (MOX)

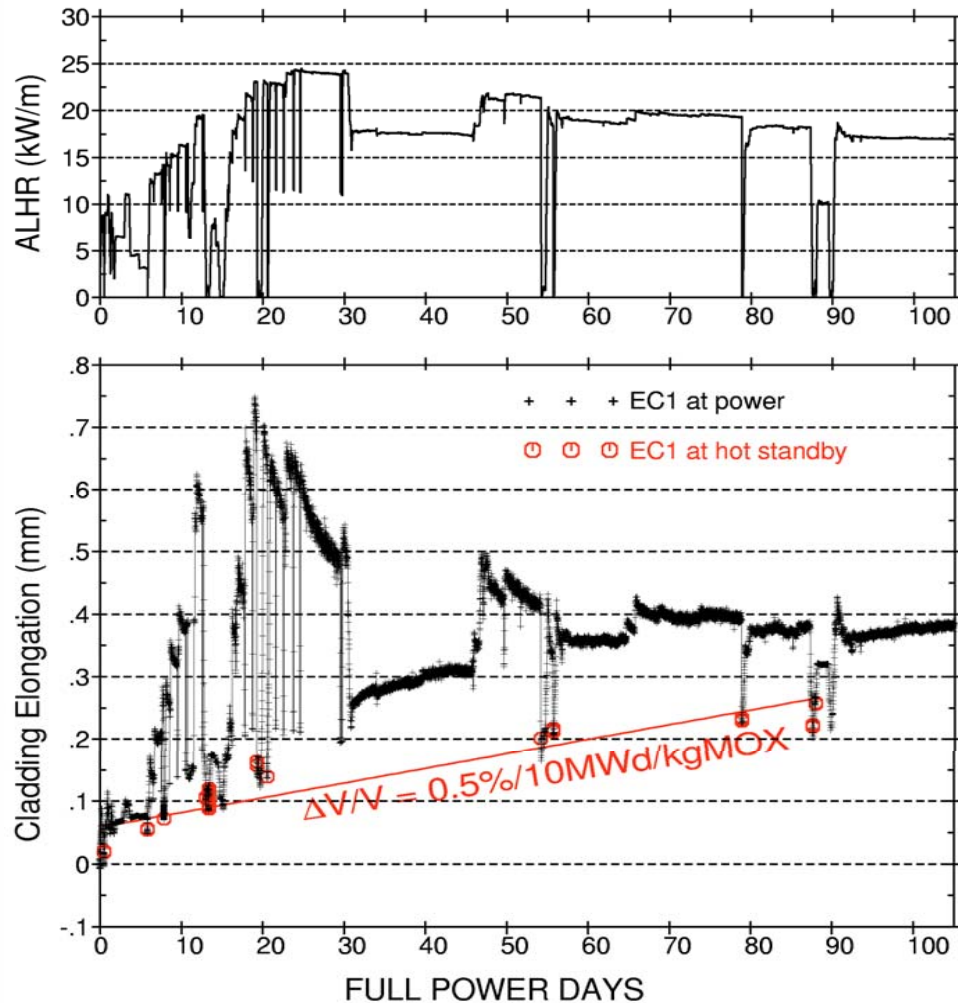

- PWR MOX rod (~46 MWd/kgOxide)
- Re-instrumented: TF + EC
- *Permanent elongation*
Clad elongation increase reflects fuel swelling
- *Relaxation*
Stronger relaxation than for UO₂ fuel at similar burnup
 - Increased fuel creep?

Re-instrumented PWR fuel:

PCMI behaviour at high burnup

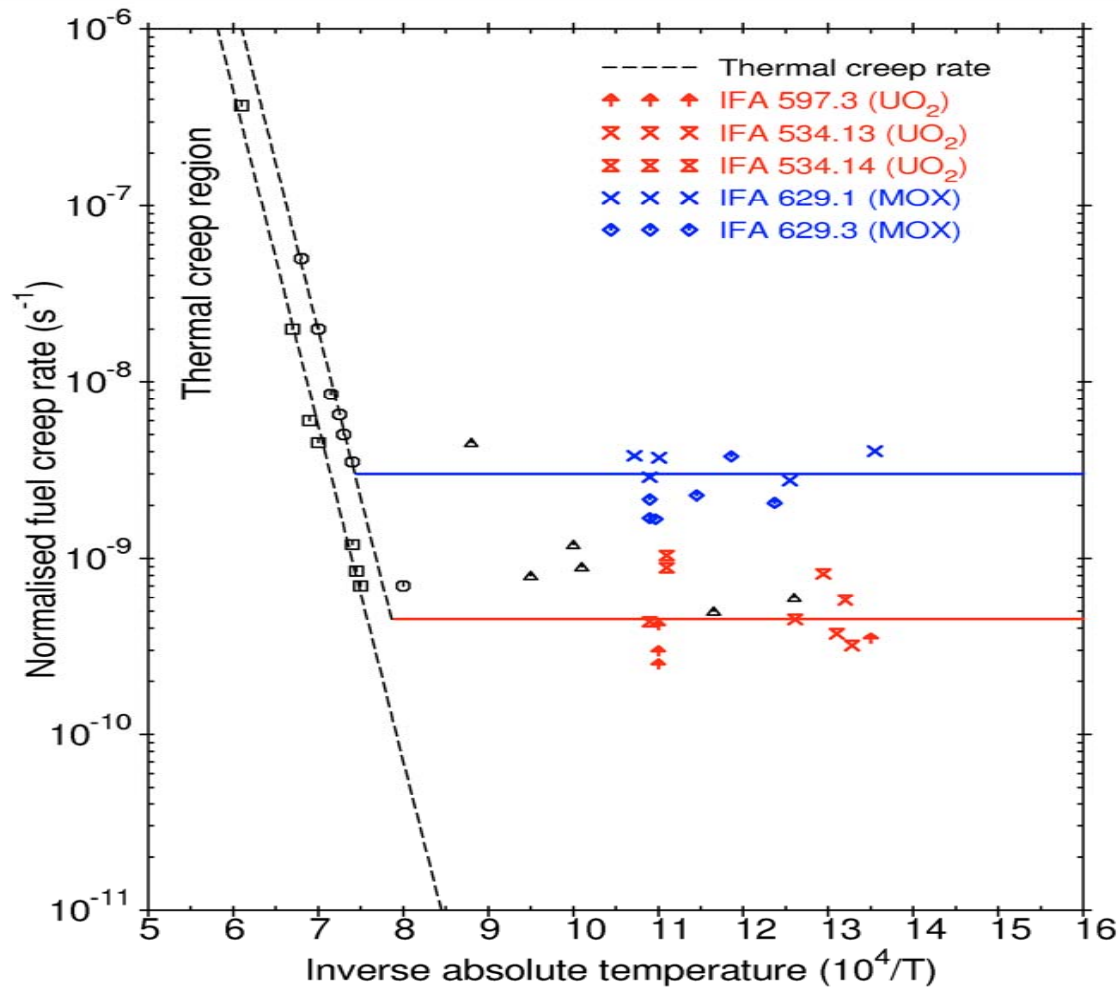

- PWR fuel rods re-instrumented with EC
- Creep rates deduced from observed relaxation rates
- MOX fuel shows higher thermal creep rates

Athermal fuel creep:

- $\epsilon \sim A f \sigma$
f = fission rate
 σ = fuel stress (≈ 50 MPa)
A = constant
- ϵ (MOX) ≈ 5 ϵ (UO_2)



Re-instrumented PWR fuel: PCMI and rod overpressure – noise analysis

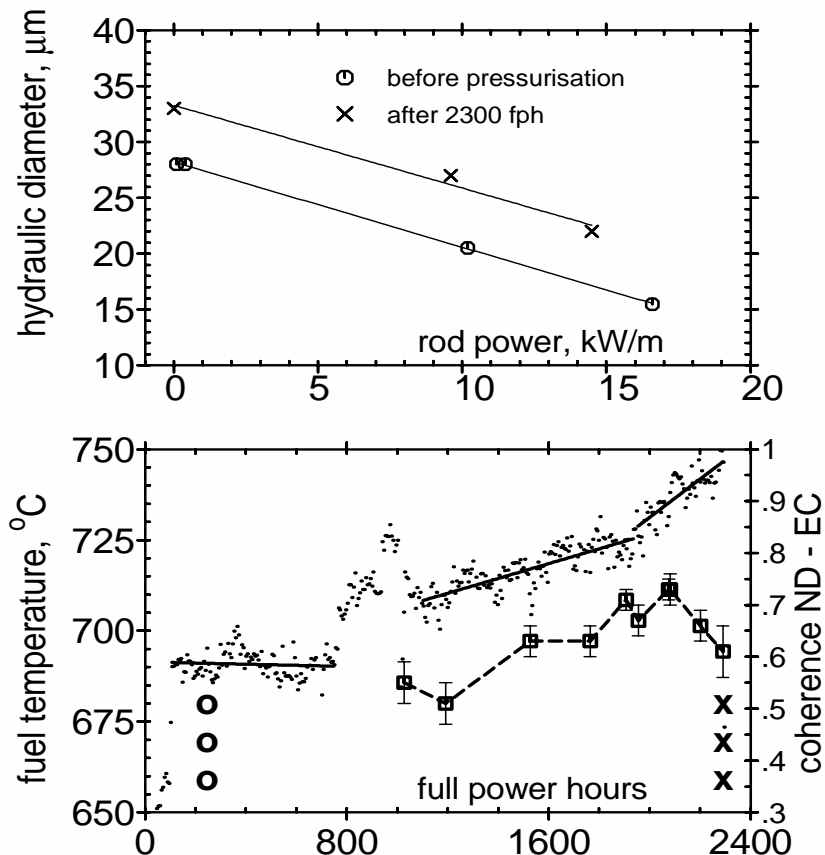

- PWR UO₂ rod re-instrumented with TF, EC and gas line
- Rod overpressure (>130 bar above system pressure) causes clad lift-off and a measurable temperature increase
- Clad lift-off causes the hydraulic diameter to increase.
- Noise analysis (power – elongation) indicates continued contact between fuel and cladding



Re-instrumented PWR fuel: Gas flow through the fuel column (High BU)

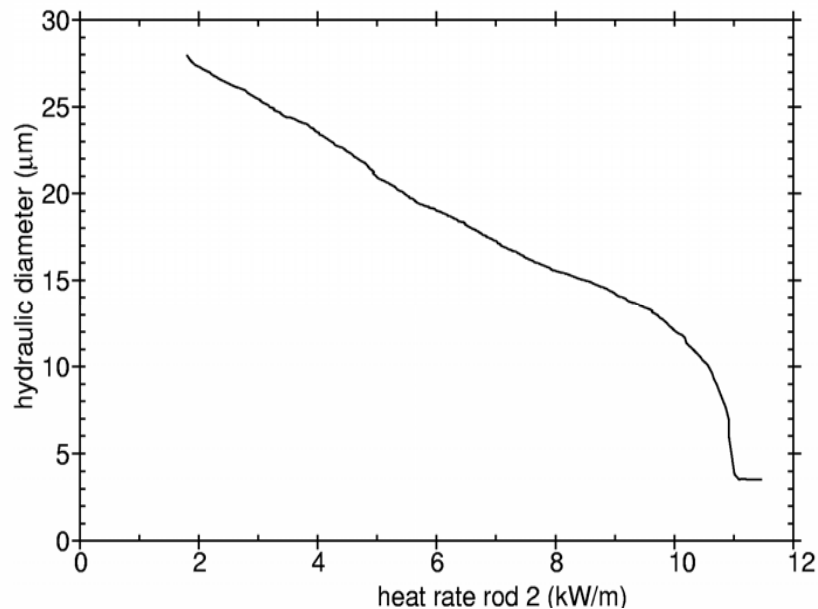

When the accommodation power level is approached, the hydraulic diameter decreases at a higher rate, similar to the onset of PCMI

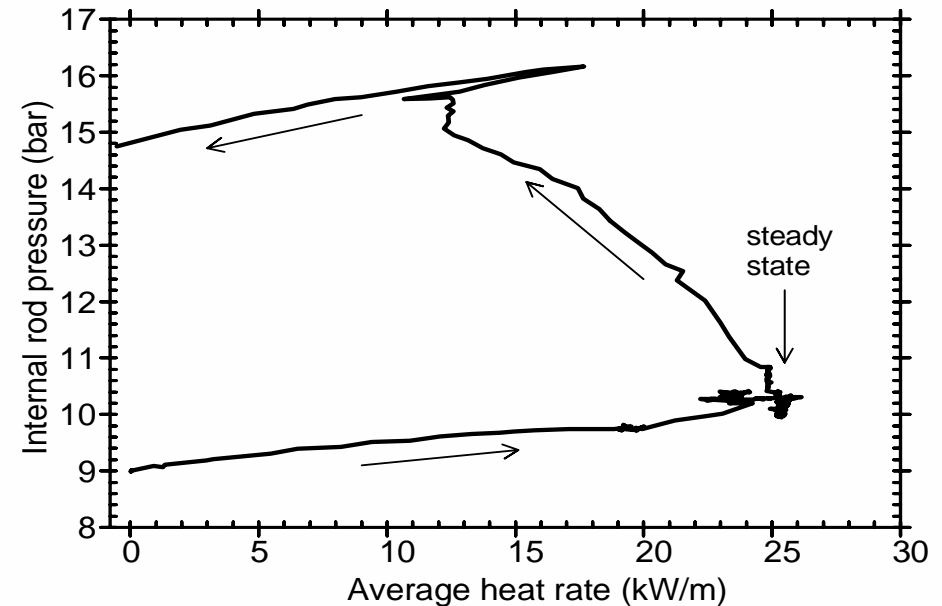

The fuel column becomes permeable after a limited power reduction. The release of the inner overpressure to the fuel rod plenum is detected then.

Re-instrumented PWR fuel:

Fission gas release onset

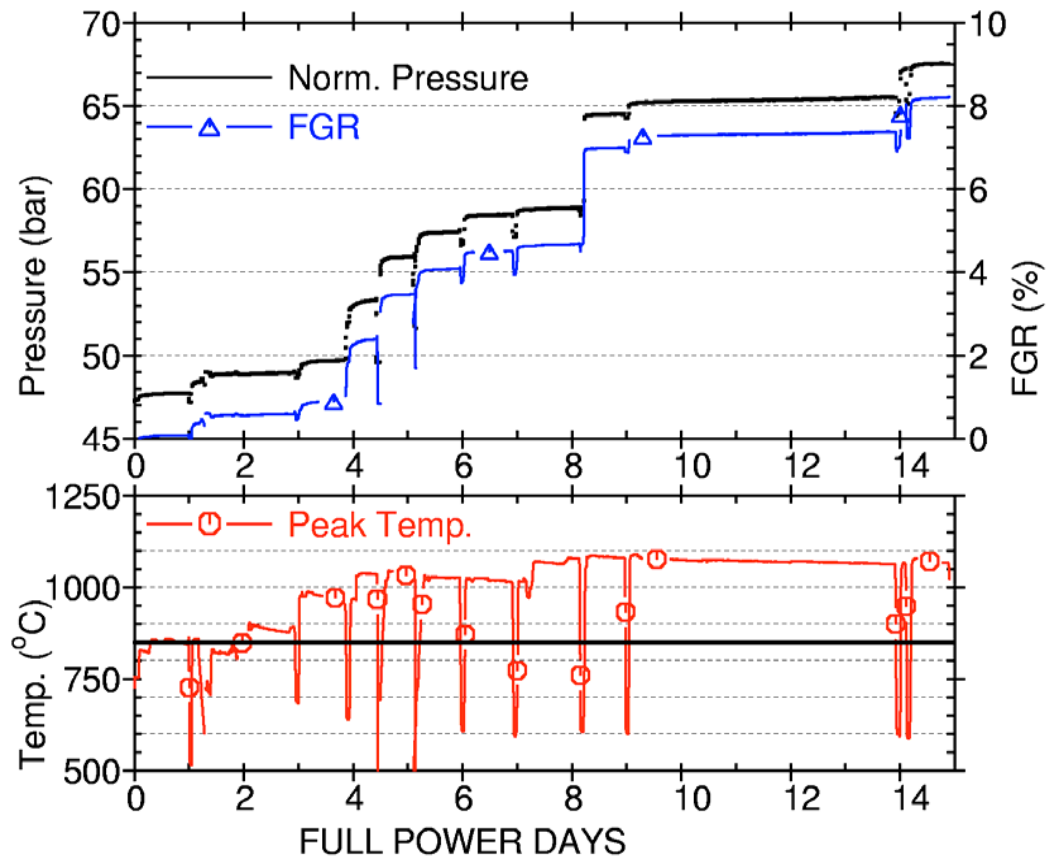

Temperature and FGR history

- PWR MOX rod (~46 MWd/kgOxide)
- Re-instrumented: TF + PF
- Stepwise power / temperature increase to establish onset of fission gas release
- For high burnup fuel, power dips are necessary in order to obtain communication with the plenum and PF instrument (tight fuel column)
- Envelope of release curve indicates diffusion controlled release



Re-instrumented PWR fuel:

Influence of grains size on gas release

- PWR UO_2 fuel (52 MWd/kg UO_2)
- Re-instrumented with PF
- According to diffusion model, in general an increased grain size will result in reduced fission gas release
- At higher power and FGR >10%, grain size increase is less effective
- Satisfactory prediction with diffusion-based FGR model (Turnbull)

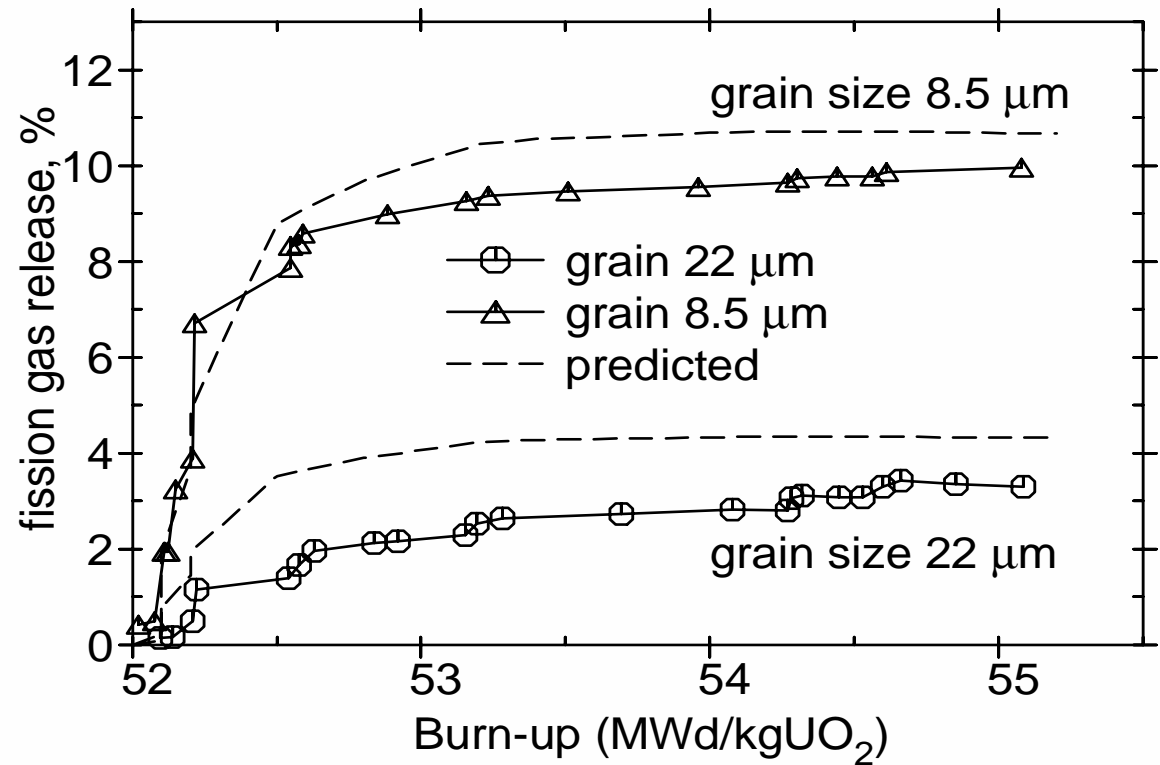

Measured and predicted FGR for UO_2 fuel with different grain sizes



Re-instrumented LWR fuel:

Onset of Fission Gas Release at High Burnup

- A very important result from the Halden Programme is the Halden (Vitanza) 1% FGR threshold established for UO_2 up to $\sim 30 \text{ MWd/kgUO}_2$
- With the re-instrumentation technique, the onset of FGR at even higher burnups can be studied

Results:

- Release onset of MOX fuel very similar to that of UO_2
- Original 1% FGR release criterion overestimates release onset temperature for $\text{Bu} > 30 \text{ MWd/kgUO}_2$
- The curve to the right shows an FGR code benchmarked against 1% release threshold (Halden data) for UO_2
- Empirical modifications:
 - resolution parameter
 - burnup dependent diffusion coefficient

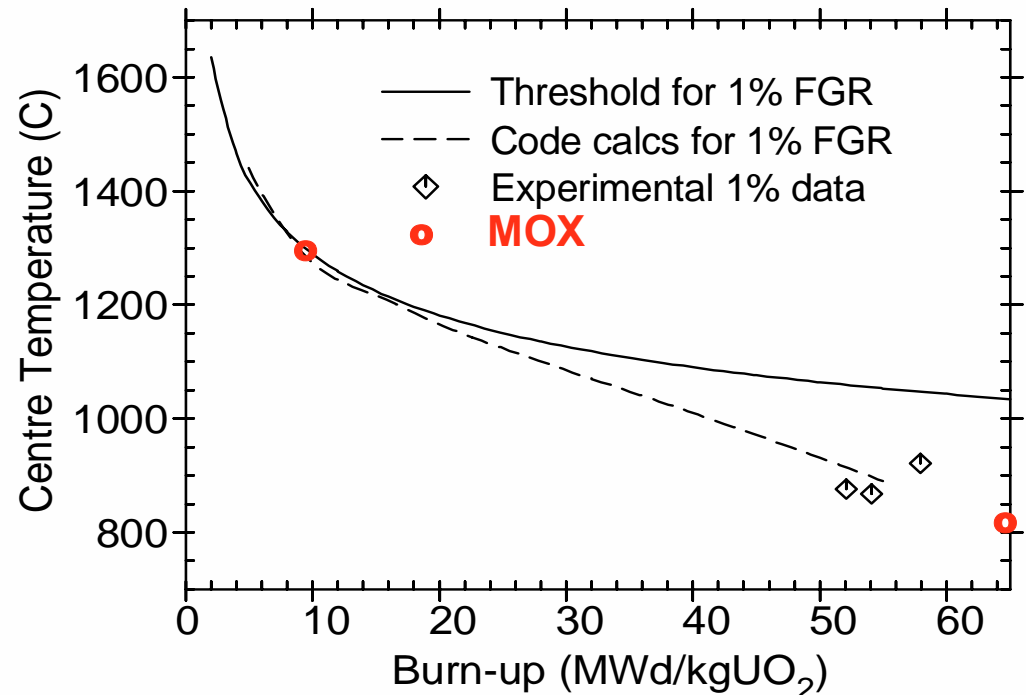

Comparison of original and revised criterion for fission gas release onset



Contents (contd.)

3. Materials testing

- a. LWR loop systems
- b. Crack growth measurements with potential drop technique
- c. Crack initiation
- d. Clad diameter measurements
 - Cladding creep
 - PWR CRUD
- e. Stress relaxation



LWR loops

- Allow testing of fuel clad and materials under simulated BWR, PWR or CANDU conditions:
 - Coolant pressure
 - Coolant temperature
 - Water chemistry



Loop schematic

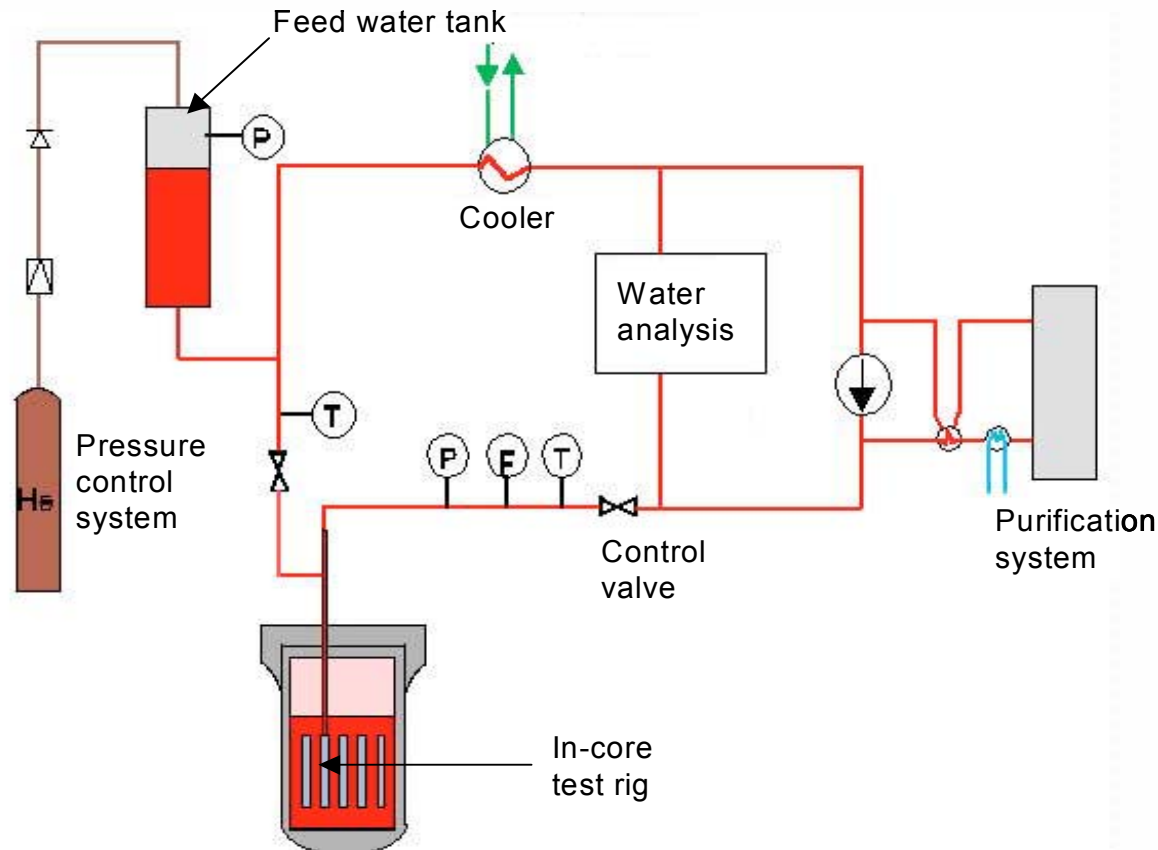

Vol: 60 – 120 l

Flow: 100 l/h -
10 ton/h

Pressure: 200 bar

Temp: 350°C

Purification system

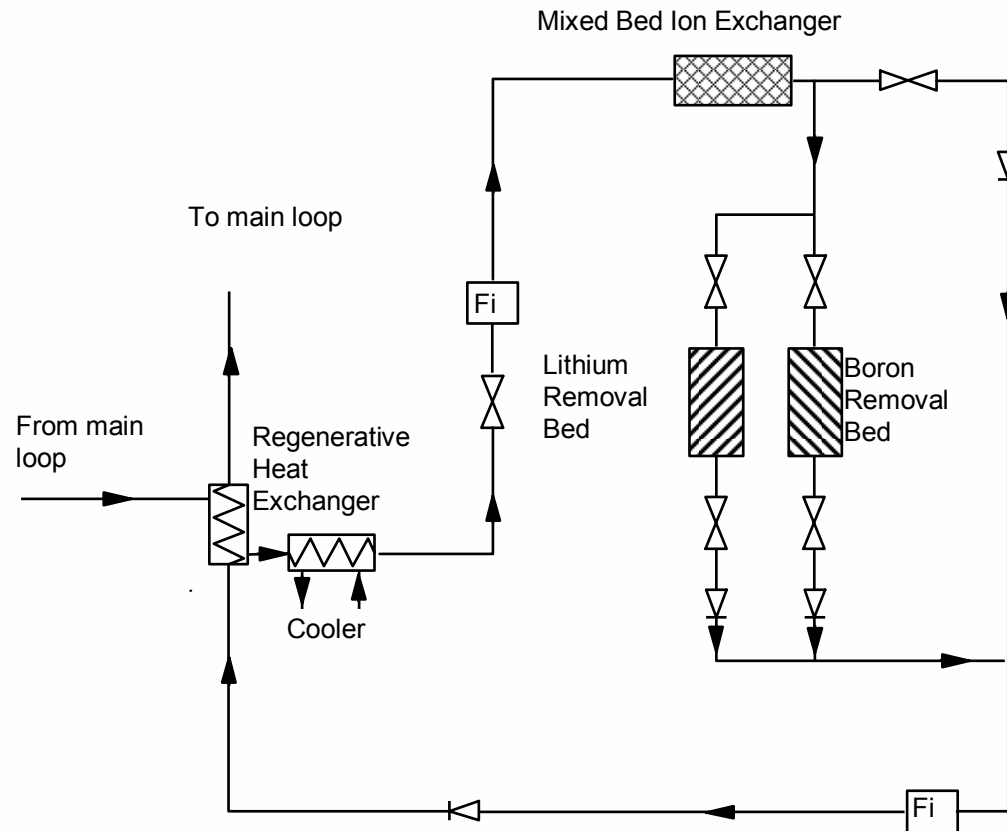

Flow: 1 – 2 loop vol/h

Temp: 40°C

Sampling / chemical addition system

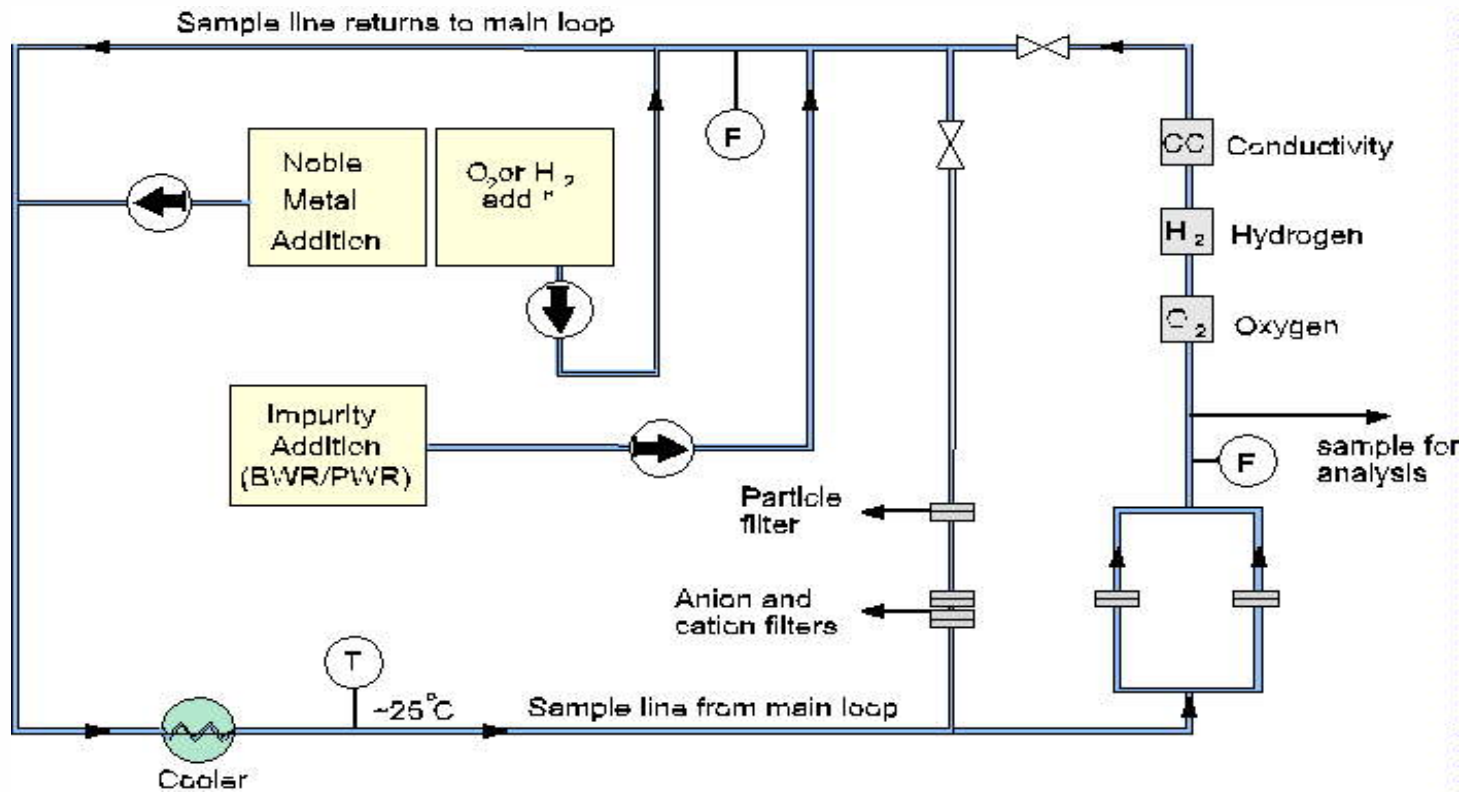

Flow:

20 – 50 l/h

Temp: 25°C

Chemical additions:

H₂ / O₂

Li / B

Noble metals

SO₄²⁻ / CrO₄²⁻

Zn

etc

Water analyses – grab samples

- Atomic absorption spectrometry (Li)
- Mannitol titration (B)
- ICP-MS (dissolved transition metals)
- Capillary Electrophoresis (dissolved anions)
- pH, total organic carbon (TOC)



Water analyses – filter samples (integrated sampling)

- Coolant passed through filter packs (particle filters and ion exchange membranes) for approx 3 hours
- X-ray fluorescence spectrometry (soluble and insoluble corrosion products)
- Gamma spectrometry (soluble and insoluble active nuclides – Co-58, Co-60, Fe-59, Mn-54, Cr-51 etc)



Typical conditions – BWR loops

- Coolant pressure 75 bar
- Inlet water temperature 270 – 288°C
- Addition of H₂ or O₂ to simulate HWC or NWC
- (eg) SO₄²⁻ addition for conductivity control
- In-core: suppressed boiling or boiling along a specific section of fuel rods



Typical conditions – PWR loops

- Coolant pressure 155 - 165 bar
- Inlet water temperature 290 – 320°C
- Sub-cooled nucleate boiling control
- Addition of 2 – 5 ppm H₂
- Addition of LiOH, boric acid (pH control)



Loops available

	Loops	Test sections
BWR – fuel	2	5
BWR – IASCC	2	2
PWR – fuel	2	8
PWR – IASCC	1	1
PWR – crud	1	1
LOCA testing	1	1
CANDU	2	3



Irradiation Assisted Stress Corrosion Cracking Studies

- Crack growth investigations
- Crack initiation studies
- Dry irradiation programmes

- Fundamental mechanistic understanding
- Assessment of possible countermeasures (e.g. HWC)
- Prediction + limits of operation for existing materials
(BWR + PWR)
- New materials development



Core Structural Component Material Studies

Crack Growth Tests

- Early studies aimed at developing suitable specimen geometries, instrumentation for monitoring crack growth + loading methods enabling on-line variation of applied stress levels
- Current investigations focus on generating crack growth rate data for irradiated materials retrieved from commercial plants



IASCC loop schematic

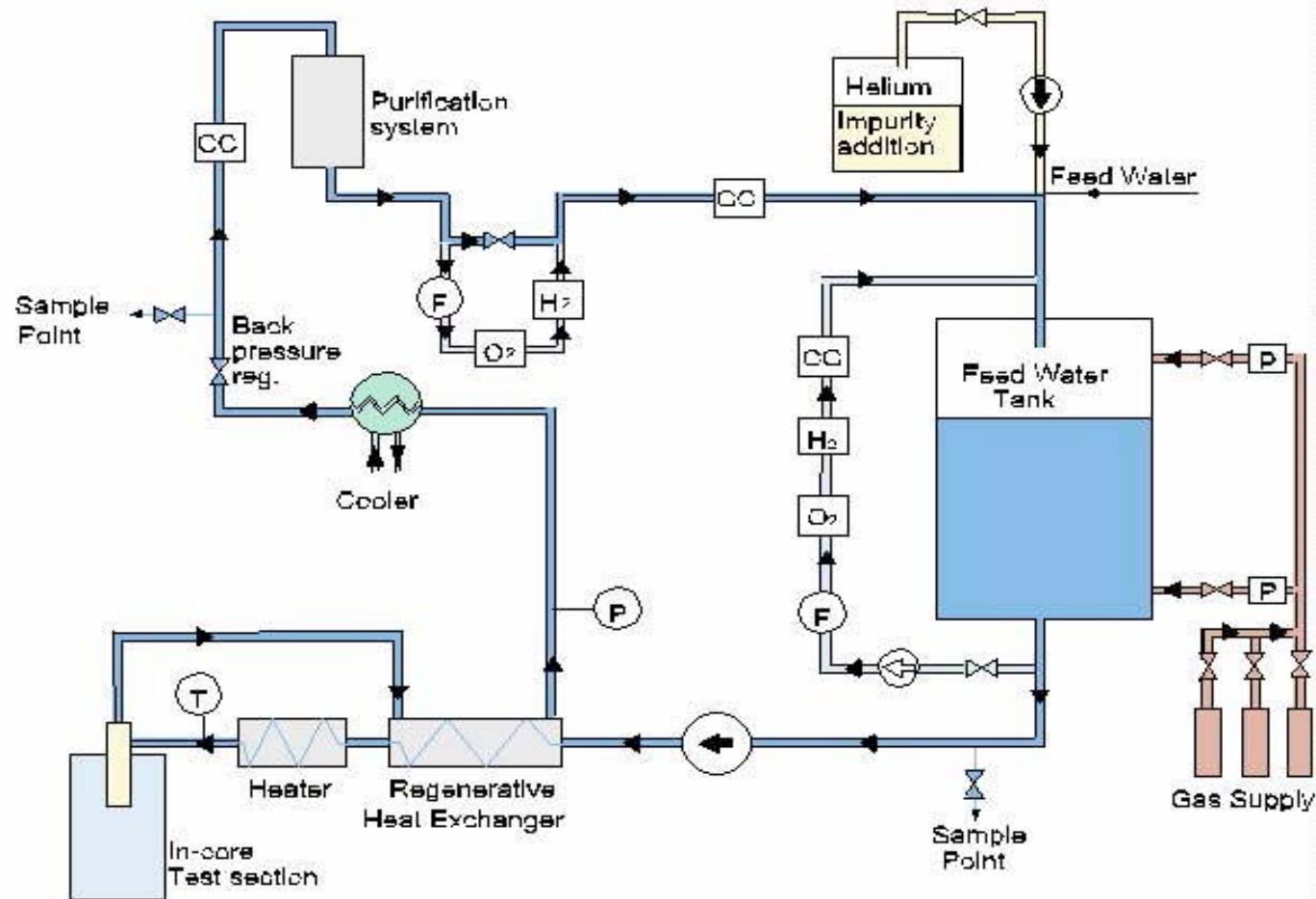

Test rig for crack-growth monitoring

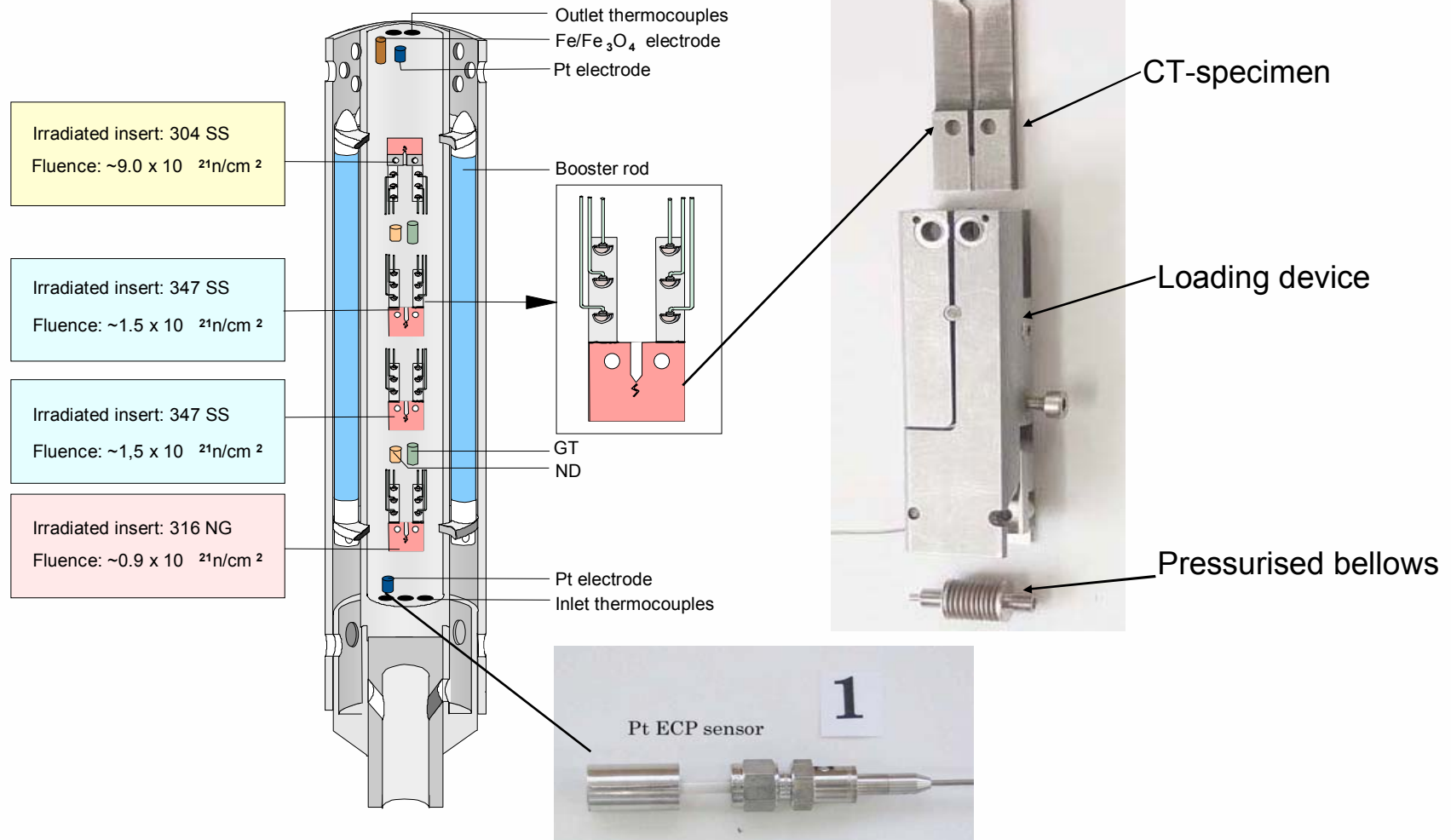

IFA 586: crack growth measured in NWC and HWC for thermally sensitised 304 SS DCB

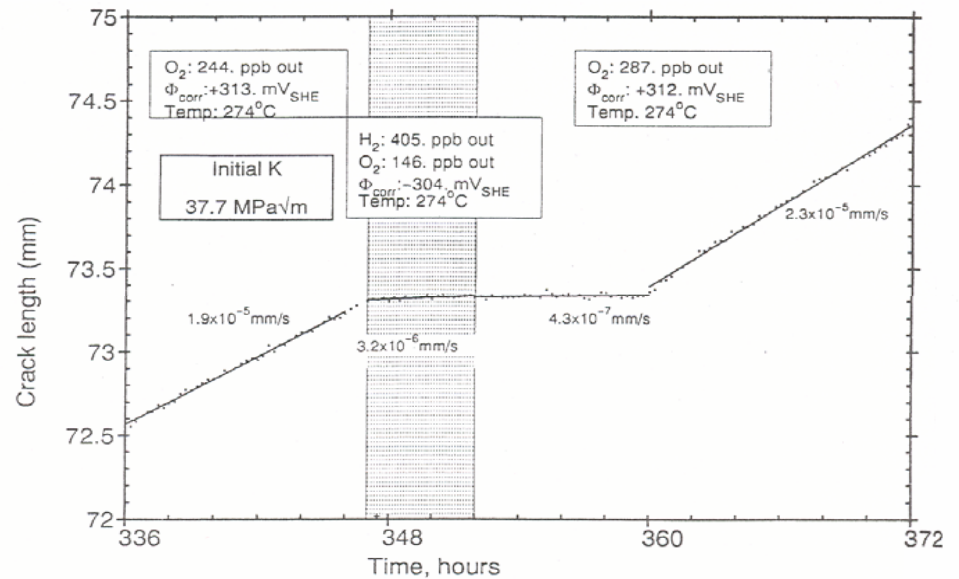
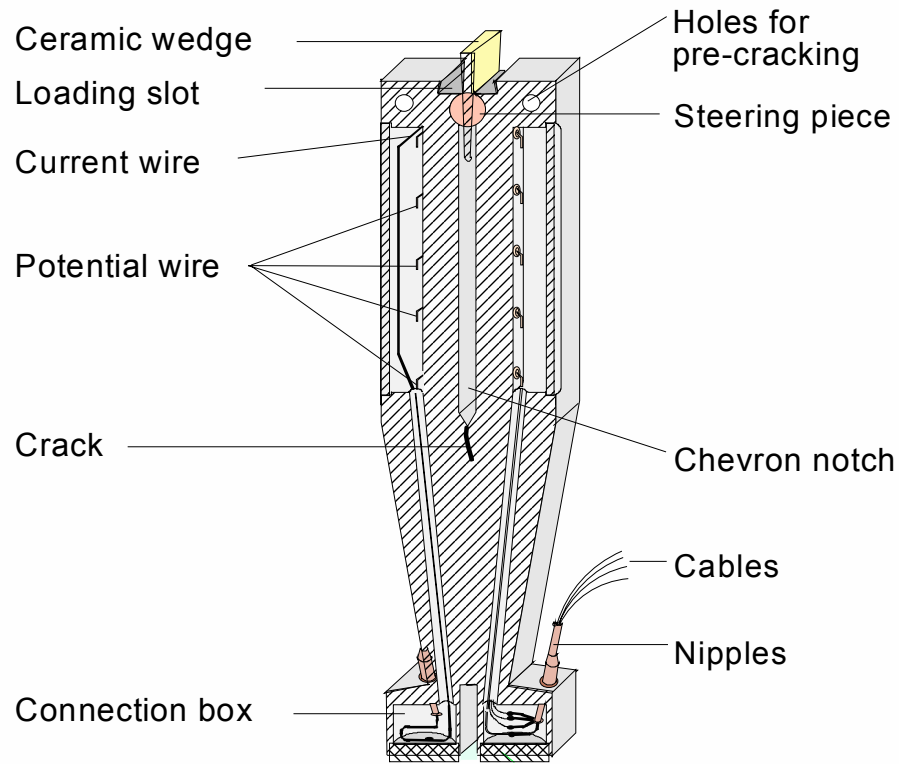

Clear benefit of HWC in slowing cracking

Current Crack Growth Rate Investigations

Objectives

- Generate long-term crack growth rate data
- Compare CGR in BWR (280-290 °C, O₂ and H₂)
vs PWR (320-340 °C, Li, B, H₂) conditions
- Use materials (SS 347, 304, 316) retrieved from commercial reactors
- Study effects of fluence (7×10^{19} n/cm² to 2.5×10^{22} n/cm²)
 - microstructure, microchemistry
 - mechanical properties (yield strength)



Compact Tension (CT) Specimen Geometries

crack propagation measured using dc potential drop method;
load applied with pressurised bellows system

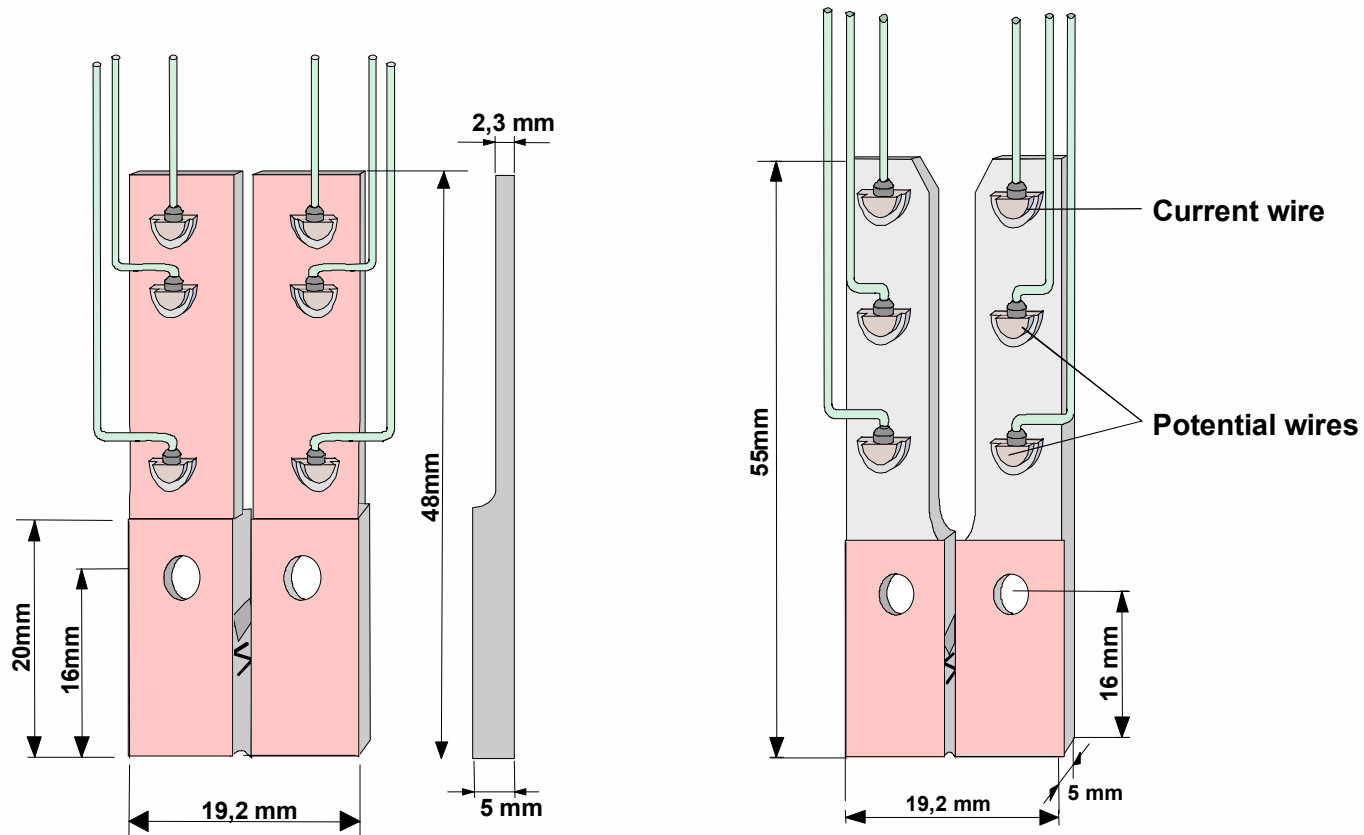

CT Specimen with Pressurised Bellows

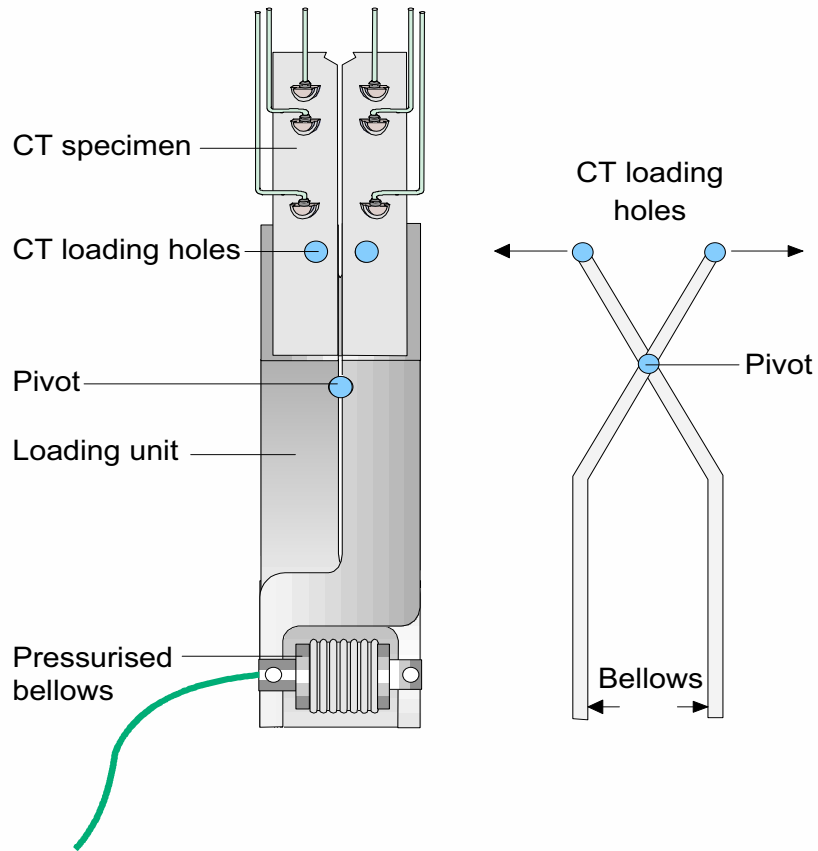

Example of Specimen Arrangement in Crack Growth Test Rigs

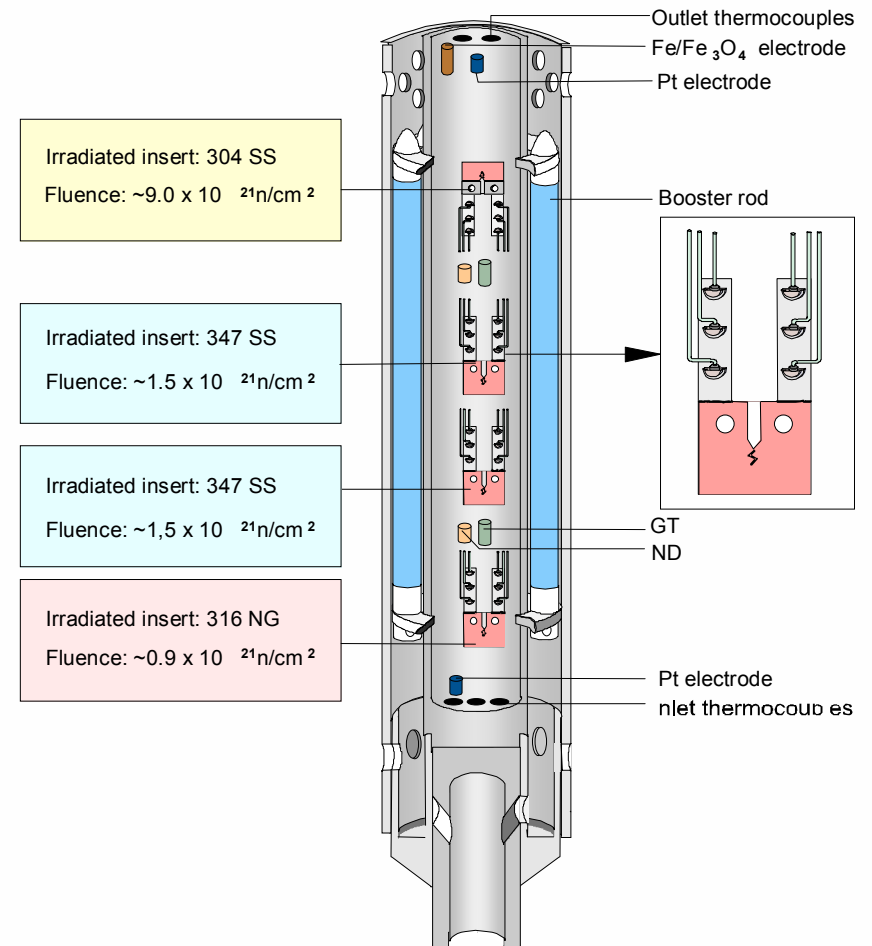

Example of long-term crack growth measurements in 347 SS with fluence 1.5×10^{21} n/cm² in BWR NWC

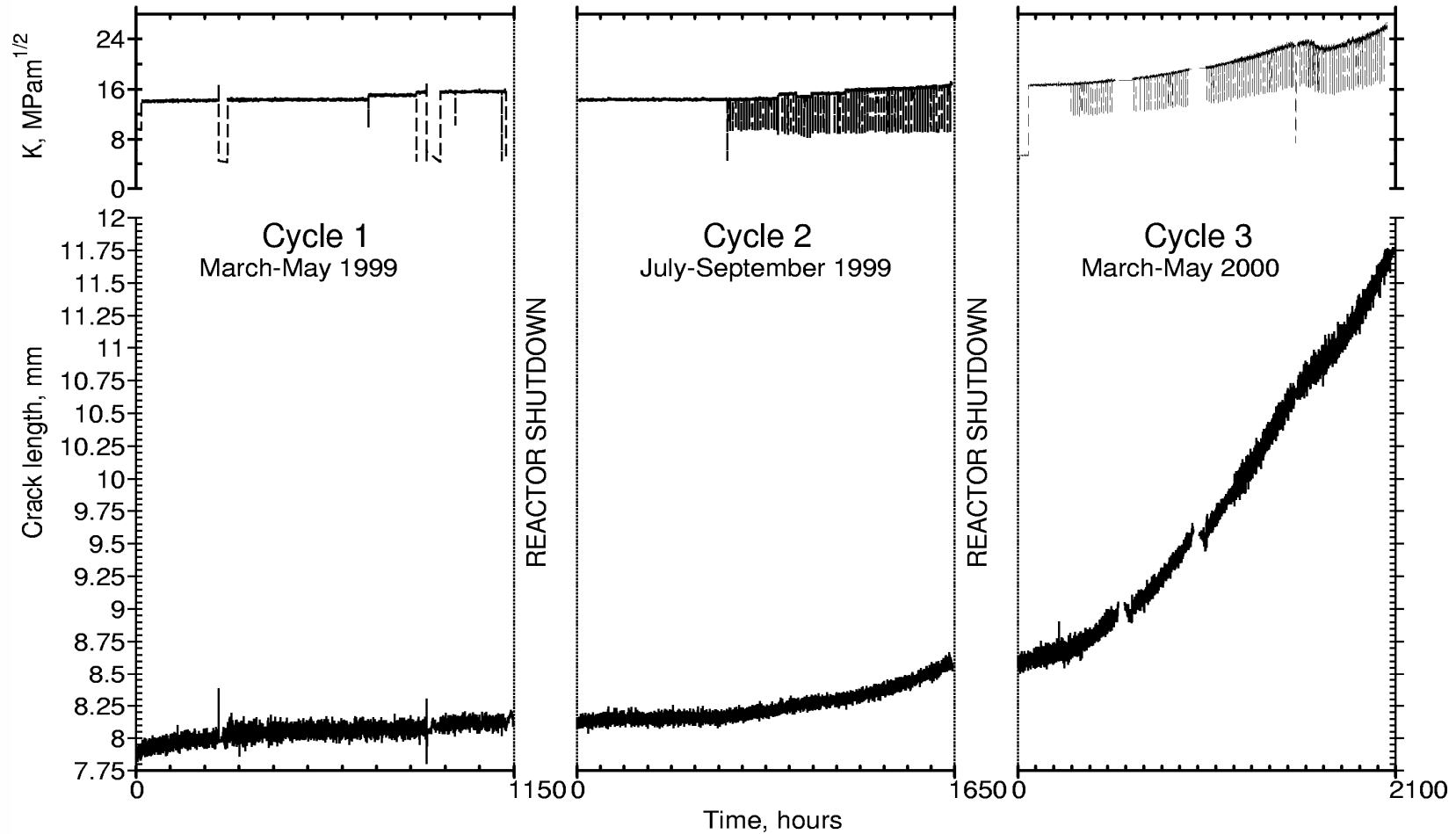

Lower fluence material – beneficial effect of BWR HWC

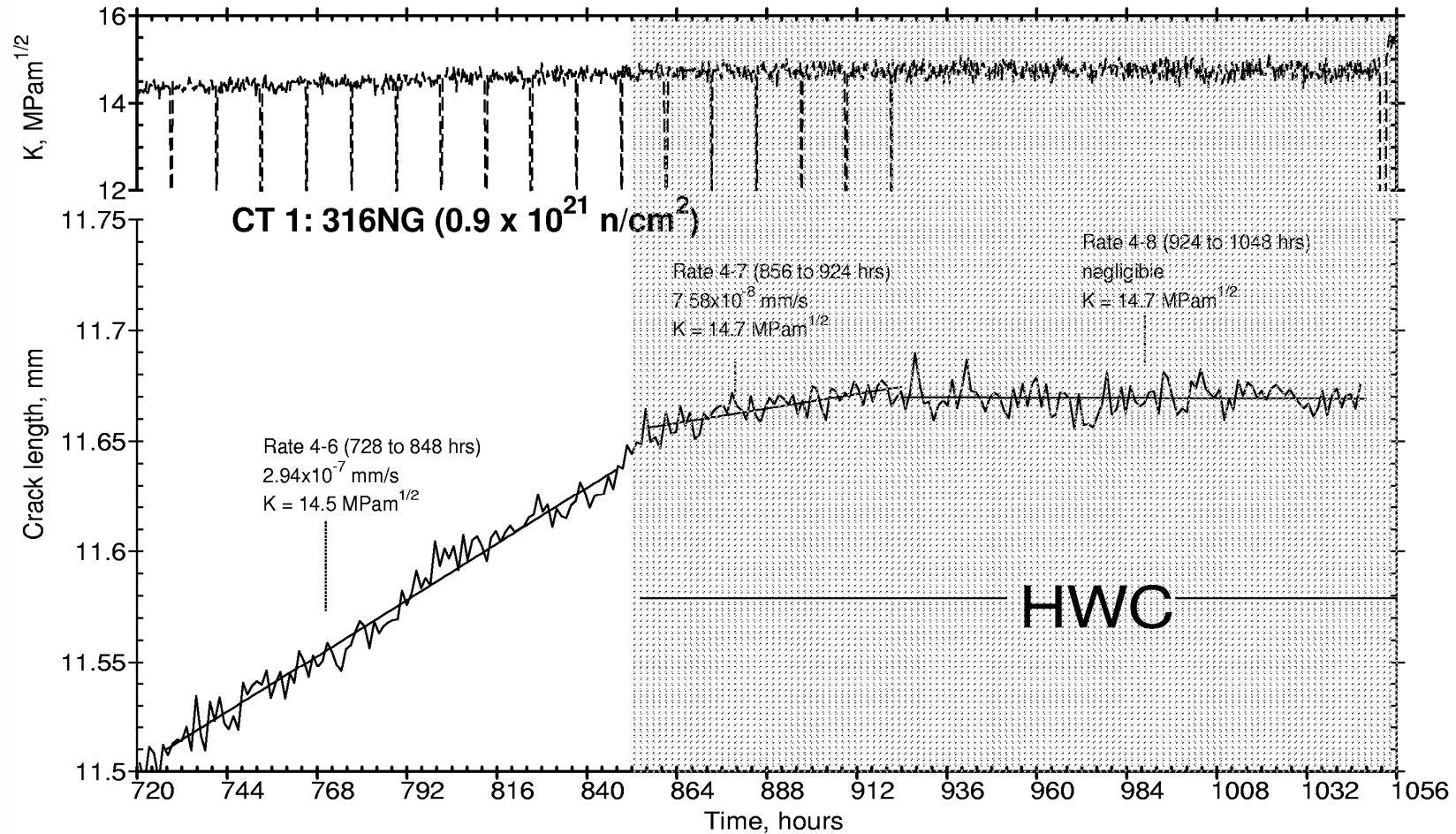

Higher fluence material – beneficial effect of HWC not clear

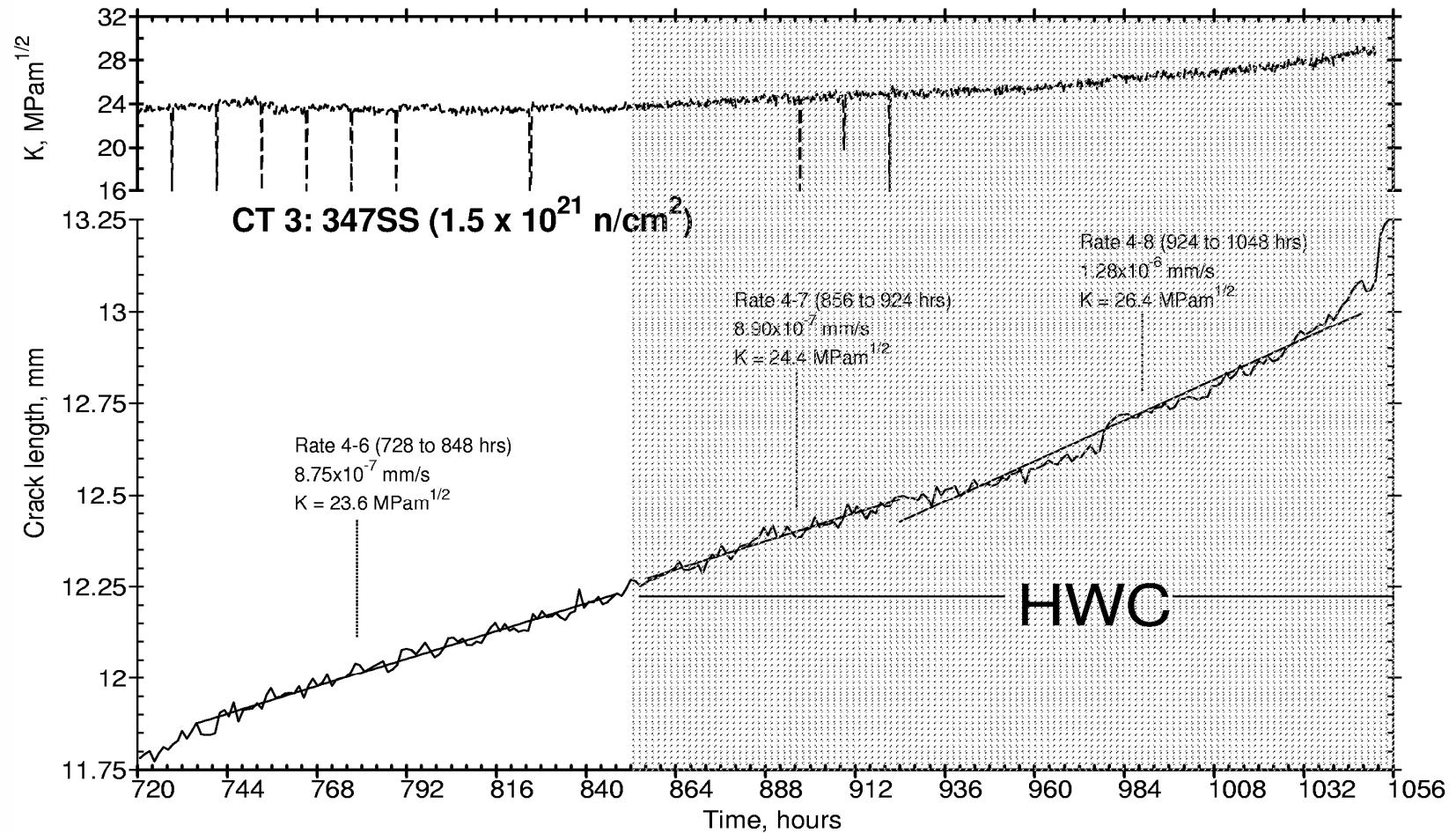

Example of crack growth rates measured for CT in PWR Conditions

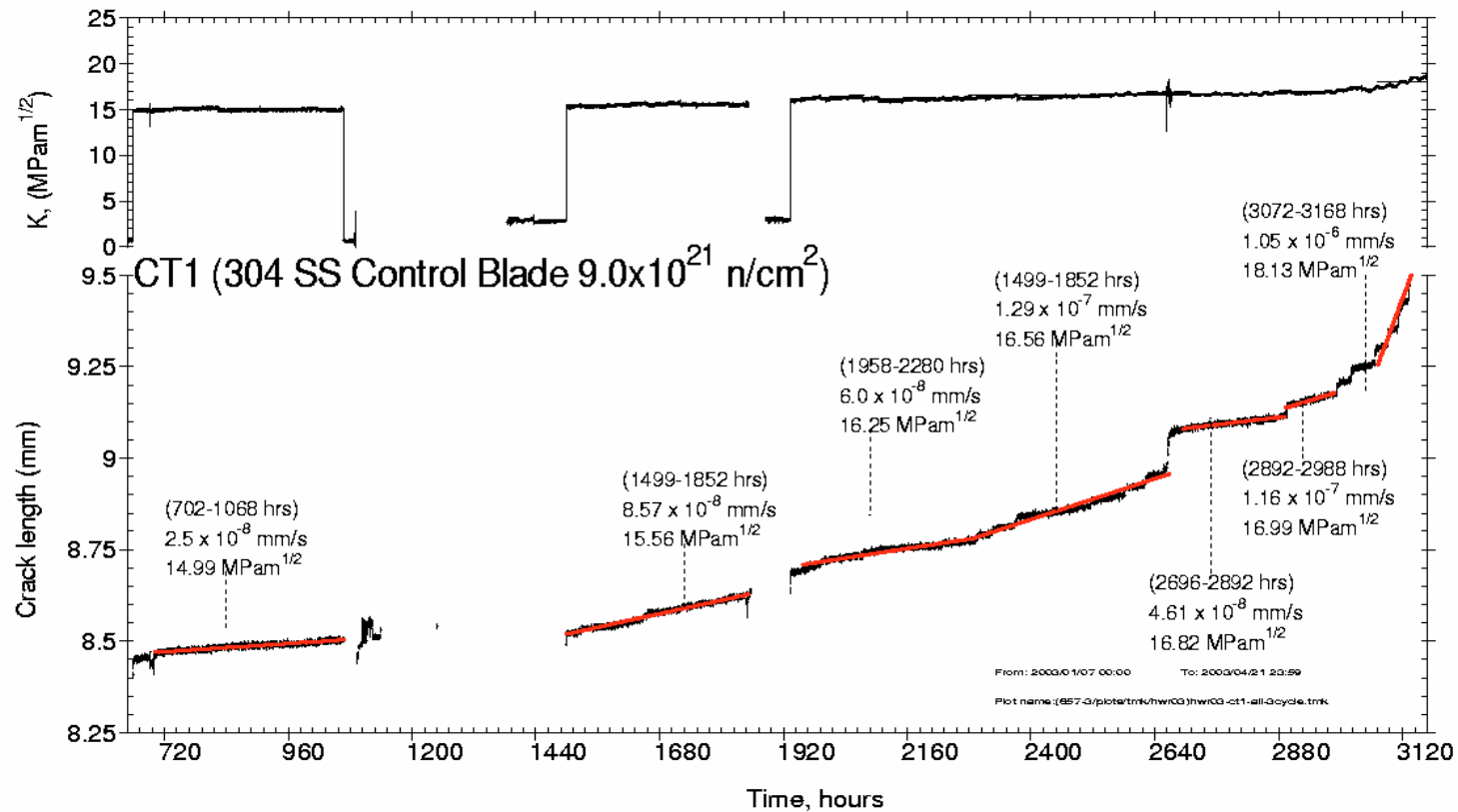

Crack growth rates measured in irradiated SS in high and low corrosion potential environments

Clear benefit of low corrosion potential in reducing crack growth rates in low dose materials

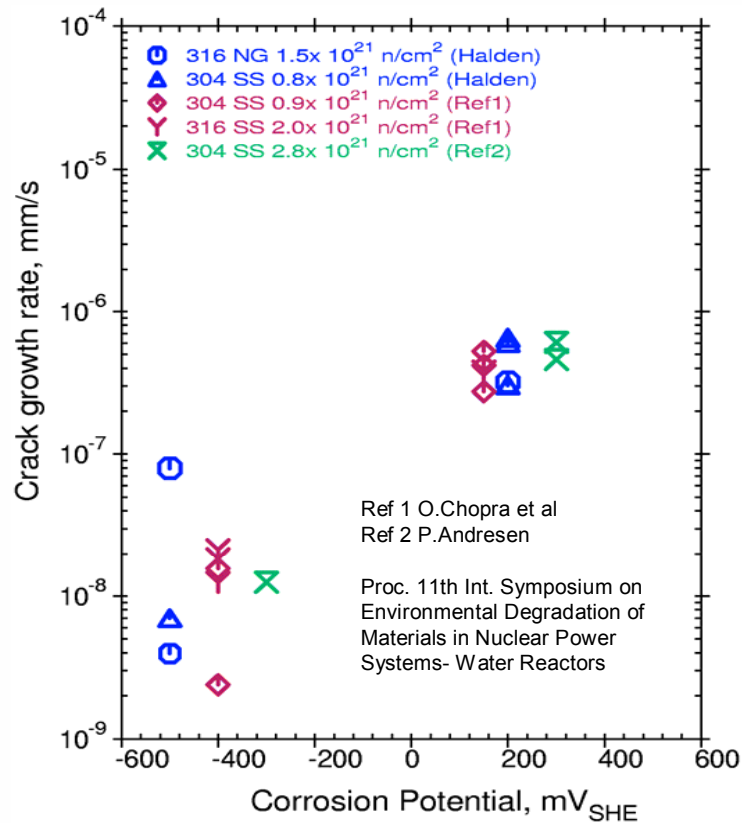

Limited benefit of low corrosion potential in reducing crack growth rates in high dose materials

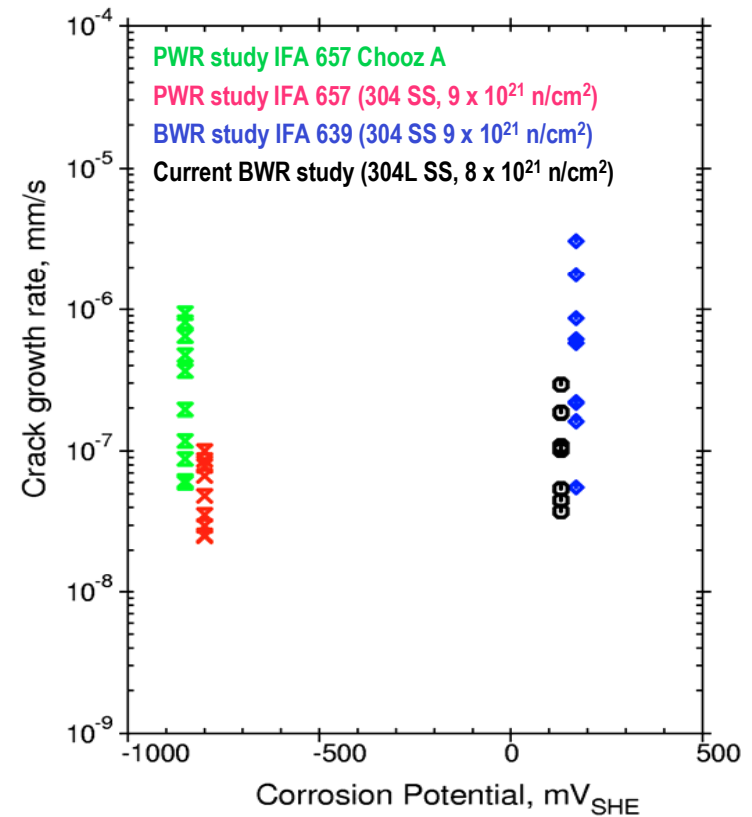

CGR vs yield strength (cold worked and irradiated materials)

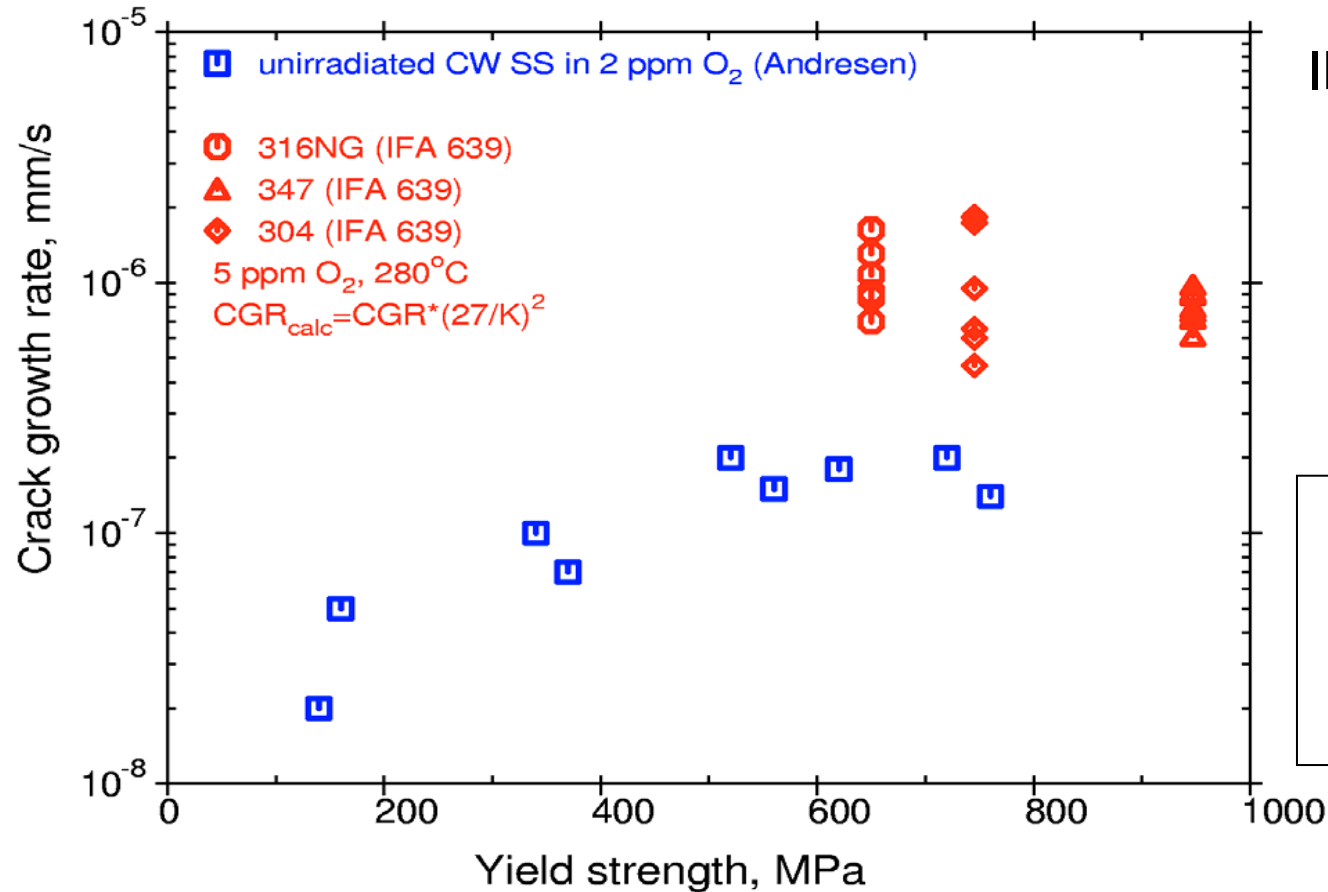

IFA-639 crack growth rates normalised:

$$CGR_{calc} = CGR_{meas} * (27/K_{meas})^2$$

Higher CGRs in irradiated material:
RIS + increased YS



Crack initiation studies

- Use of pressurised tubes to study
 - effects of material, stress + fluence on crack initiation
- Use of tensile specimens for integrated time-to-failure (crack initiation, propagation, final failure) tests
 - effects of water chemistry on susceptibility to crack initiation
- Both investigations with on-line instrumentation (LVDTs)



IFA 618 Crack Initiation Test

Objective:

- determine susceptibility to crack initiation in pressurised tube specimens (pre-pressurised or with gas lines) as a function of fluence, stress level and material
- sensitised + s.a 304 SS, 316 SS, cw 347 SS
- stress levels 0.8 to 2.75 x YS
- exposure to BWR NWC conditions

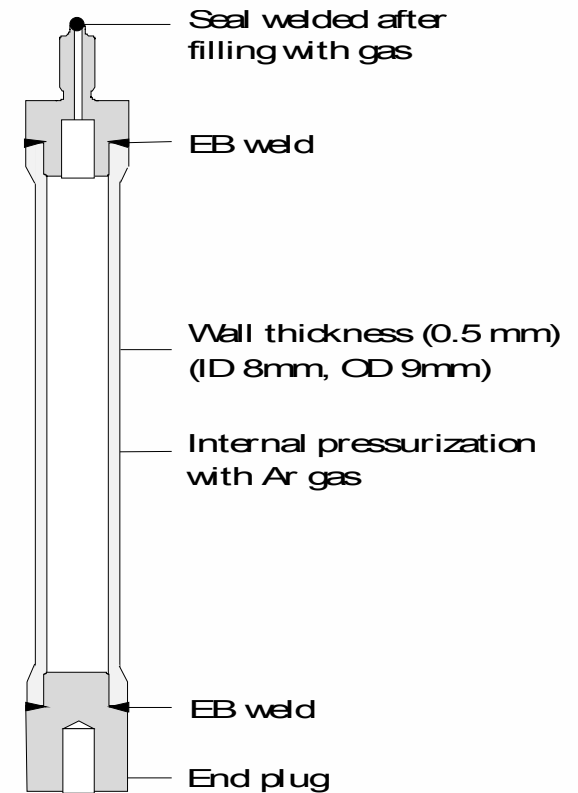

Crack initiation study, IFA 618: On-line detection of specimen failure by means of change in elongation signal + release of activated Ar-41 filler gas into loop system

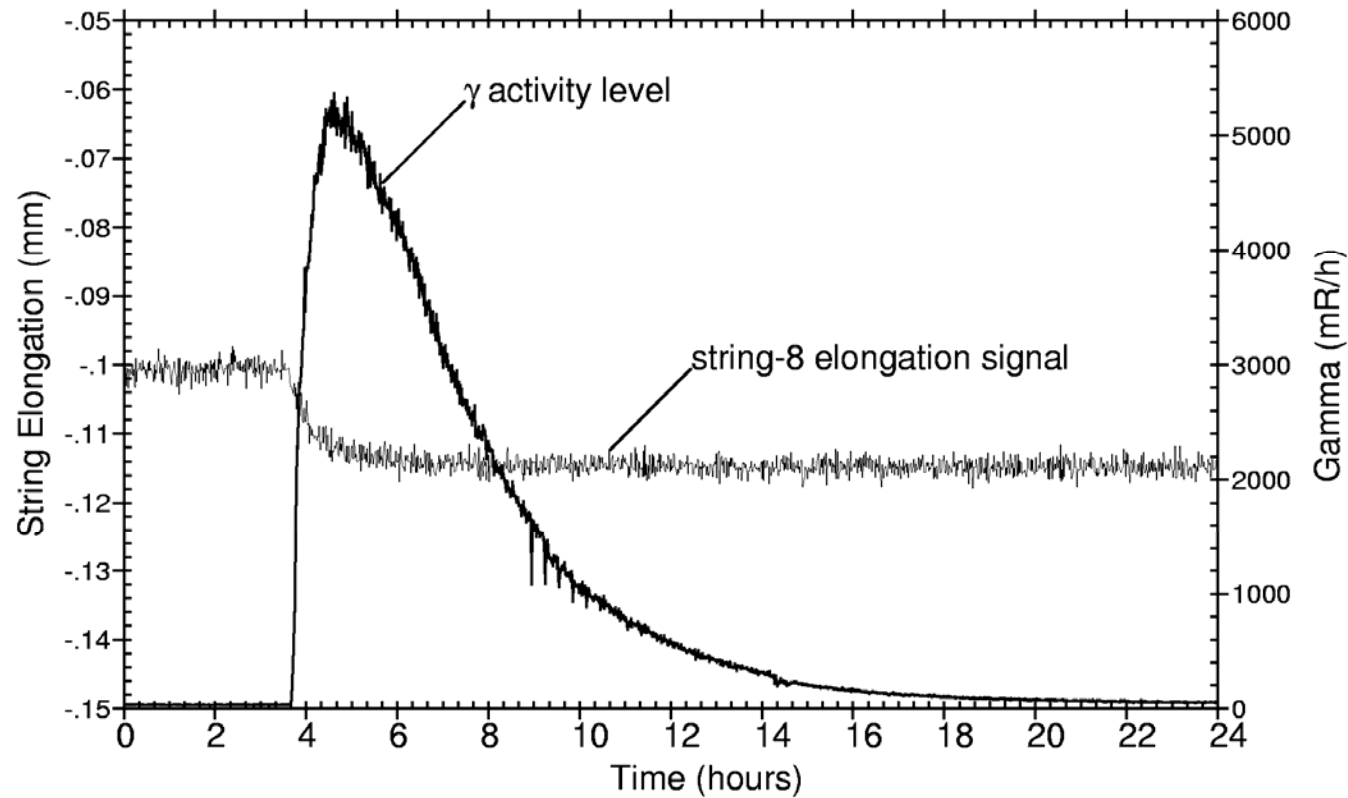

BWR Crack Initiation (Integrated Time-to-Failure) Study IFA-660

Objective

- Determine effectiveness of HWC in reducing susceptibility to the *initiation* of cracks in irradiated material

Experimental

- 30 miniature tensile specimens prepared from 304L SS (8×10^{21} n/cm², YS 718 MPa)
- Load (77- 86 % of YS) applied by means of bellows
- On-line monitoring of specimen failures (LVDTs)



BWR Crack Initiation (Integrated Time-to-Failure) Study IFA-660

Experimental contd

1st loading:

Expose 30 specimens to "NWC" (5 ppm O₂) for several cycles;
record no. of failures

2nd loading:

Expose replacement set of specimens to "HWC" (2 ppm H₂) for
several cycles; record no. of failures

Comparison → effectiveness of HWC



Specimen geometry IFA-660

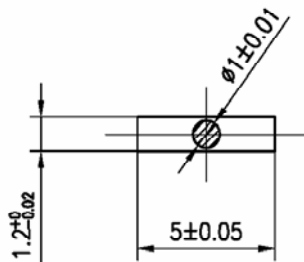
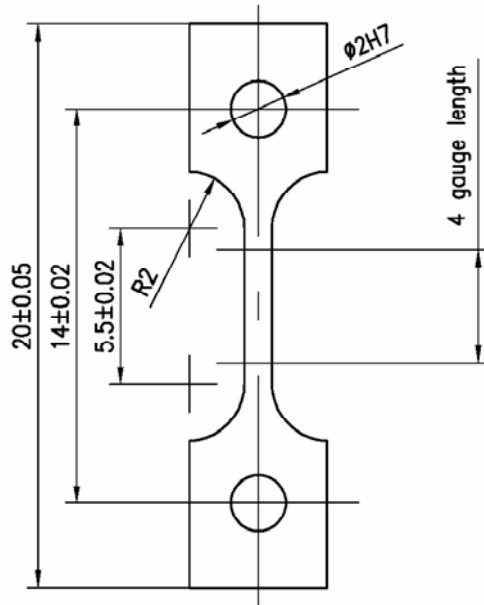

Miniature tensile specimen

- cylindrical, smooth, 1 mm diameter gage
- 30 specimens in rig

Material

- 304 L SS ($\sim 8 \times 10^{21}$ n/cm²) Barsebäck 1
- microstructure / mechanical properties saturated
- susceptible to SCC
- close to EOL fluence of e.g. top guide
- also used in BWR CGR test (IFA 658)

Instrumentation

- Specimens arranged in pairs
- Identified by means of small and large gap spacers inside bellows
- Bellows collapse on specimen failure
- LVDT movement identifies failed specimen

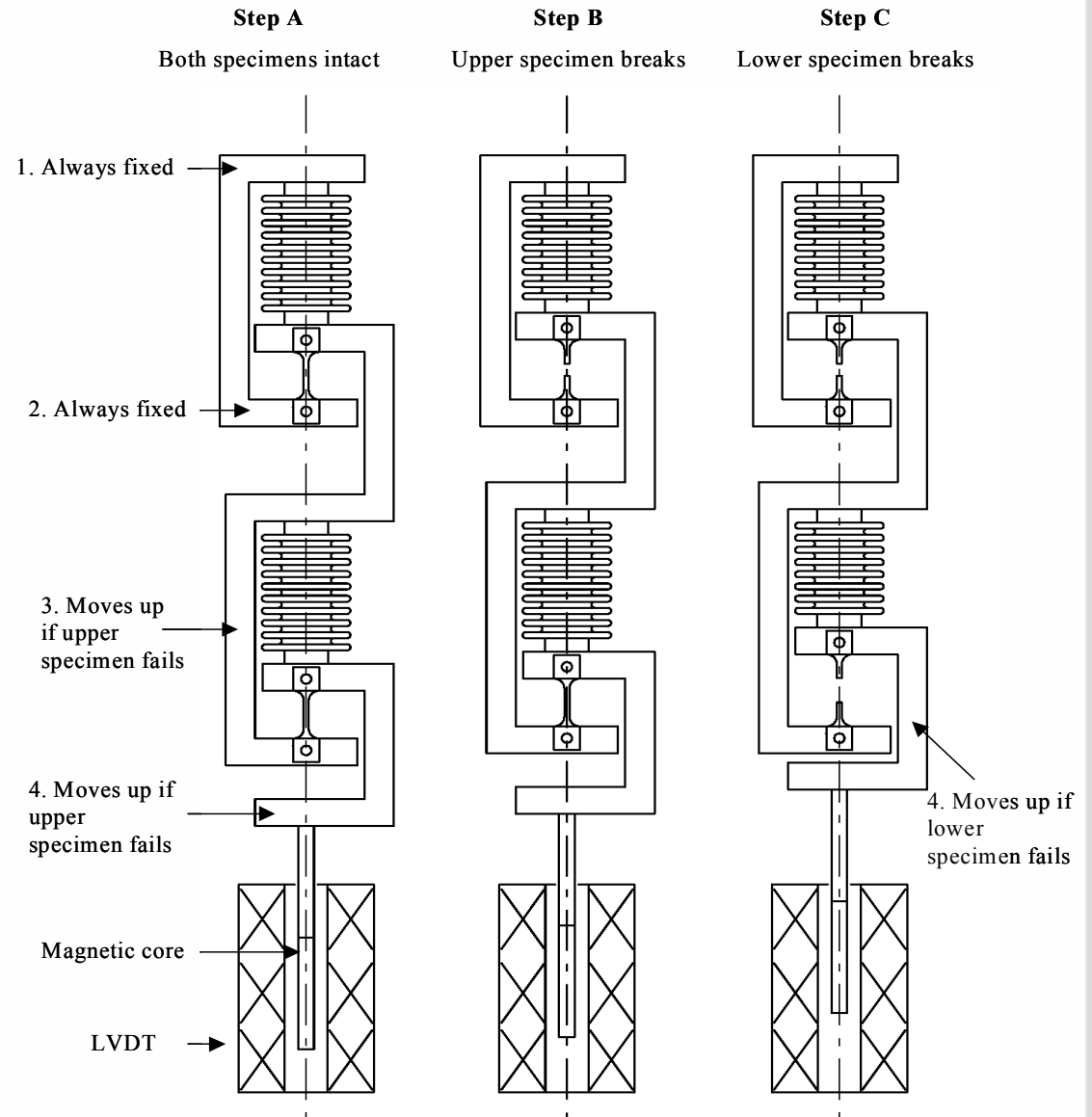

Temperature profile through IFA 660

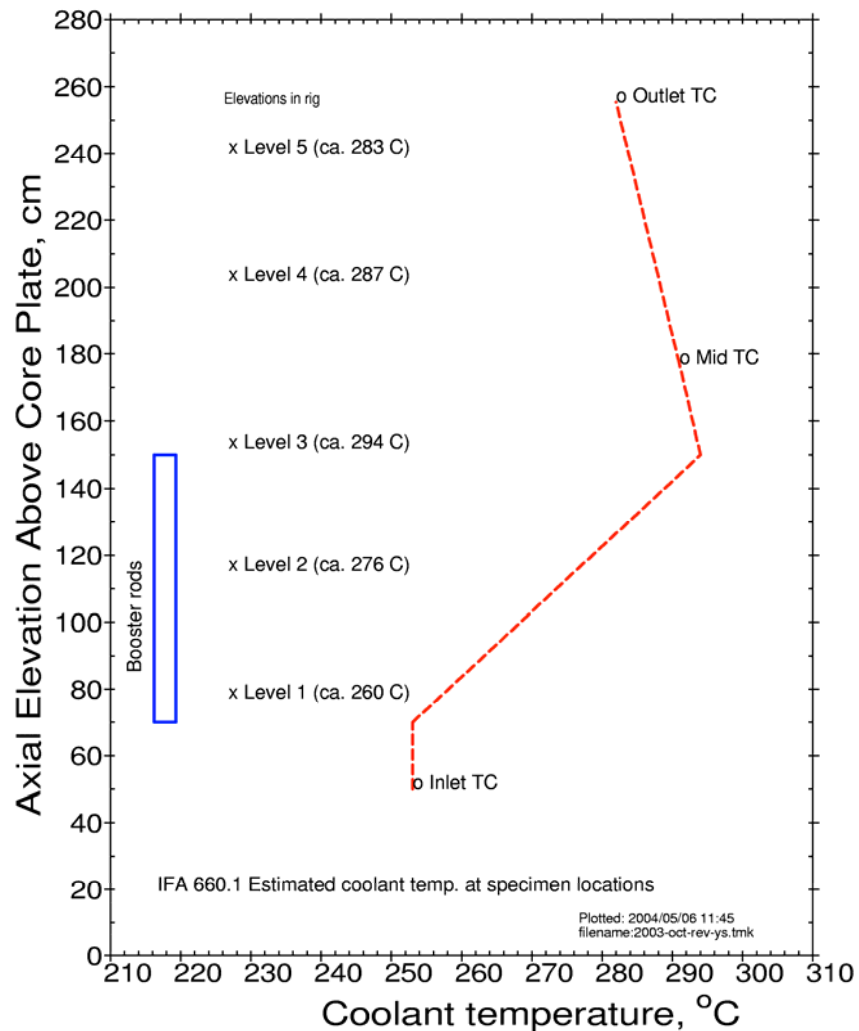

Specimen arrangement in rig:

- Arranged in pairs at 5 elevations
- Six specimens (3 pairs) per elevation
- 18 specimens in high flux position;
12 in low flux position

Coolant temp. :

- 255-290 °C

Water Chemistry:

- 5 ppm O₂ inlet ("NWC")
- 0.08 μS/cm inlet / 0.15 μS/cm outlet



Stress level on specimens determined by pressure difference between system & inner gas pressure at operating temperature:

$$\sigma_{\text{applied}} \propto \frac{\Delta P * 49.03 * 2}{a_{\text{specimen}}}$$

where

σ_{applied} = stress applied to specimen (MPa)

49.03 = bellows cross sectional area (mm²)

ΔP = differential pressure (MPa)

a_{specimen} = x-sectional area, gauge region (mm²)

% YS on specimens

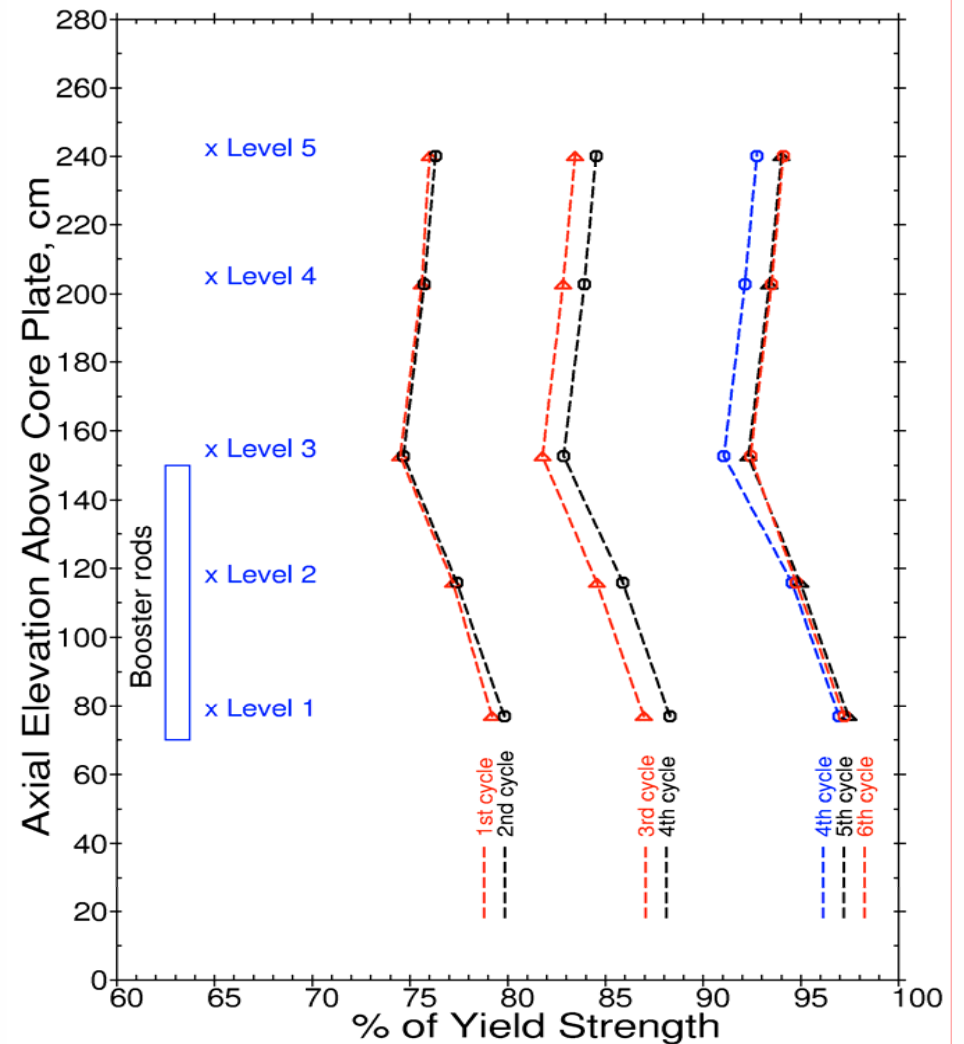

Example of Specimen Failure (Specimen No. 24 from Unit 12)

(failed at 6070 fph (> 2MW), ~50 hrs after stress level increased from ~77 to 83 % YS)

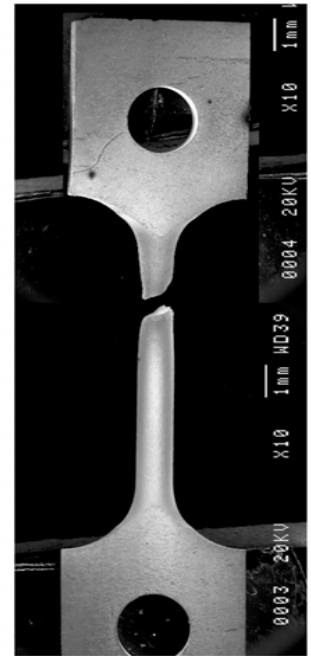
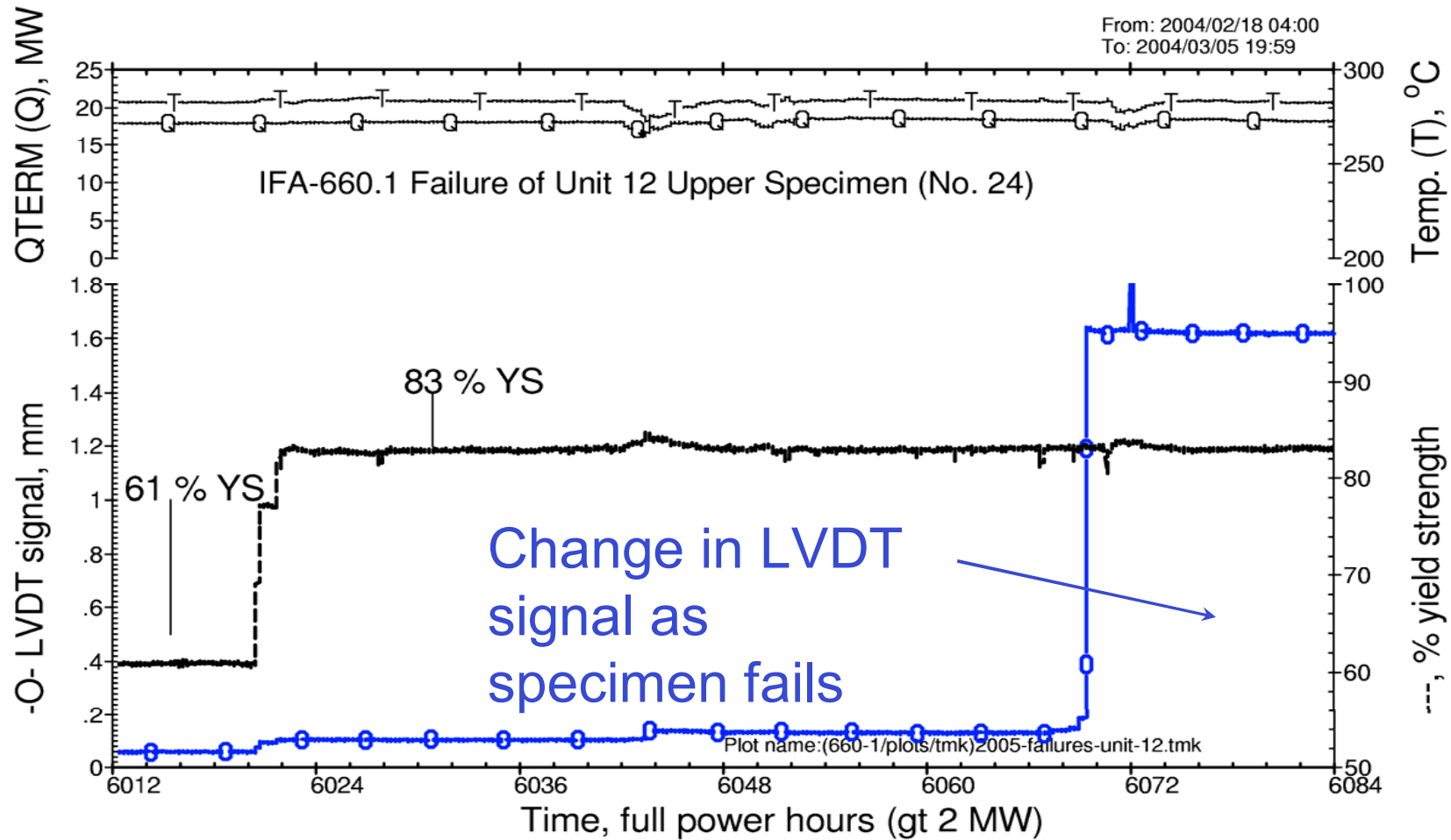

Diameter Gauge (DG)

- Provides data on fuel rod diameter profile.
- Instrument based on the LVDT principle.
- Differential transformer with two feelers on opposite sides of the fuel rod.
- DG moved by hydraulic system while a position sensor senses the axial position along the rod.
- Operating conditions: 165 bar, 325°C

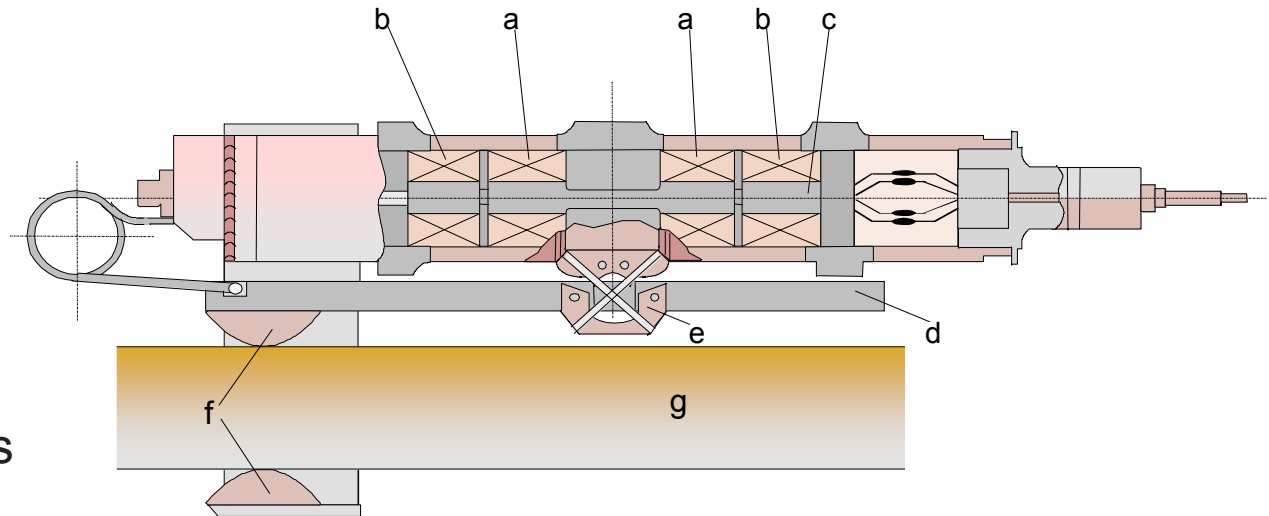

- | | |
|--------------------|----------------------------|
| a: Primary coil | d: Ferritic armature |
| b: Secondary coil | e: Cross spring suspension |
| c: Ferritic bobbin | f: Feelers |
| | g: Fuel rod |



Creep and growth of Zr-based materials

Provide engineering data on creep and growth of zirconium alloys caused by various operating conditions:

- clad creep-down (compressive, BOL)
- clad creep-out (tensile, MOL to EOL)
- guide tube creep and growth (bilateral)
(axially compressive)

In-core diameter measurements provide direct data on primary and secondary creep behaviour.



Cladding Creep Test Rig Design

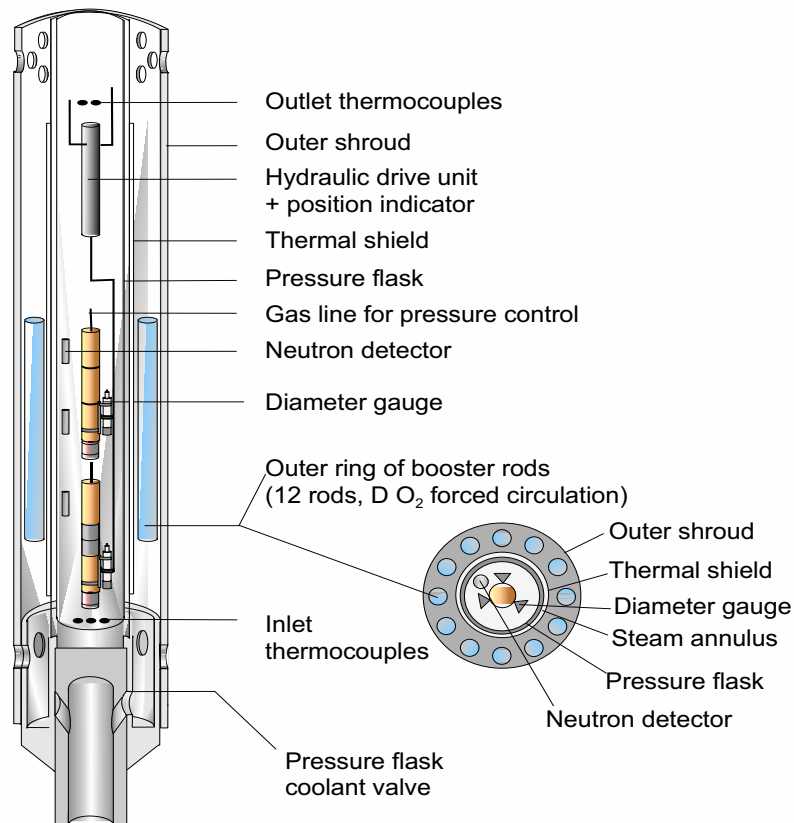

- Pressure flask with high enrichment booster fuel connected to a PWR loop
- 2 internally gas pressurised closed-end cladding tubes
- 4 segments in-flux: VVER, ZIRLO, M5 and BWR (GE)
- 1 seg. out-of-flux BWR (GE)
- 2 scanning contact diameter gauges for OD changes

Halden creep test series (Diameter gauge)

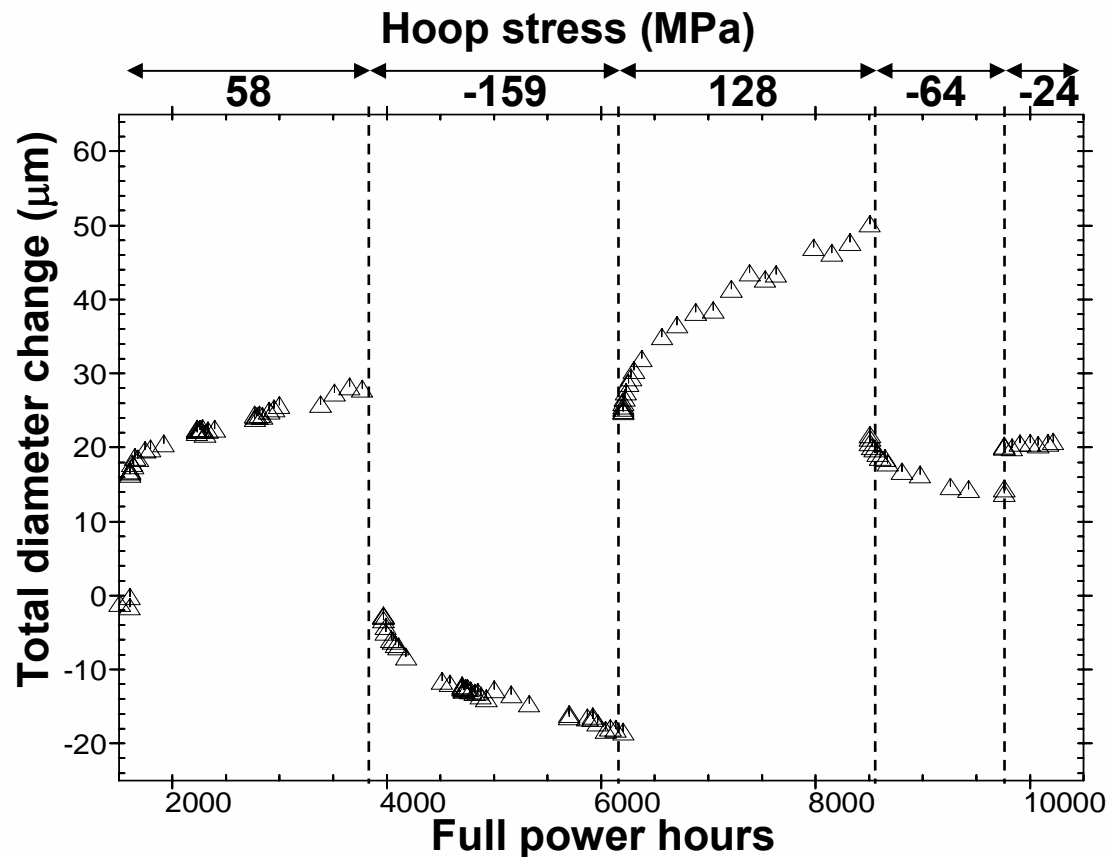

- **IFA-585**
 - 1992 – 1997 (~15,000 fph)
 - high fluence Zry-2, fresh + pre-irradiated Zry-4
- **IFA-617**
 - 1999 – 2001 (~3500 fph)
 - pre-irradiated M5, Zirlo, Zry-4, Zry-2
- **IFA-663**
 - 2002 – 2005 (~8400 fph)
 - M5, Zirlo, Zr1Nb, GE-P5



On-line evidence for crud loading by use of DG measurement

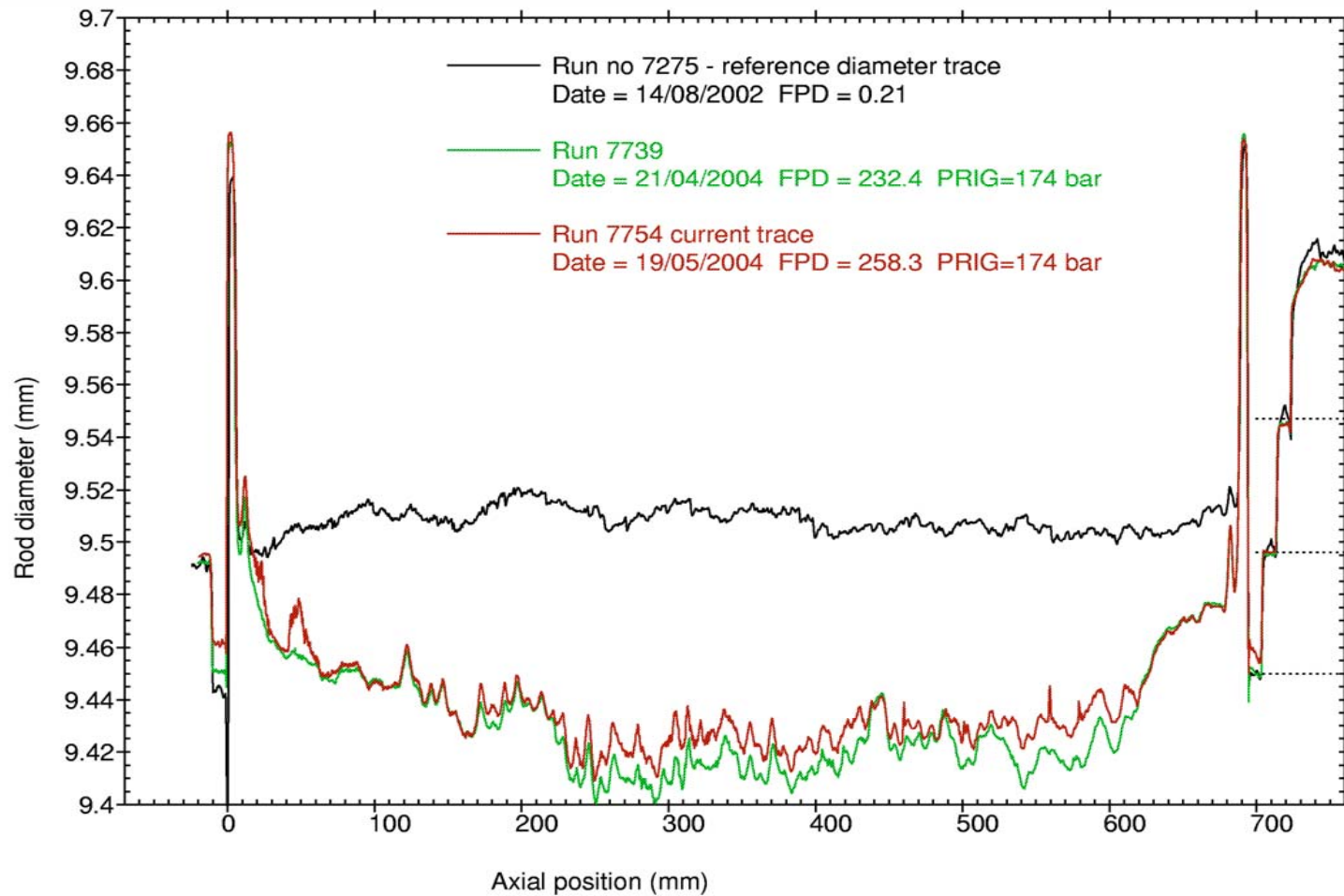

Stress Relaxation Test IFA-669

Objectives

- Establish the technical feasibility of on-line stress relaxation measurements during irradiation
- Measure the irradiation stress relaxation of materials used in PWR and BWR plants
- Benchmark irradiation stress relaxation data to irradiation creep data
- Evaluate the applicability of the Halden stress relaxation data to other reactors (EBR II + commercial PWRs)



Stress Relaxation Test IFA-669

Specimens

- 30 tensile specimens (~2.5 mm, gauge length ~50 mm)
 - 12 samples in instrumented units
 - 18 samples in uninstrumented units

Materials

- CW 316, CW 316LN, CW 316N, SA 304 SS; Aged Alloy 718

Test Conditions

- Stress Levels 70-345 MPa
- Temperatures 290, 330 and 370 °C
- Fluences 0.4, 1.6 + 2.0 dpa

Irradiation Arrangement

- Irradiation in inert (dry) irradiation conditions
- Maximum dose level 2 dpa ($\sim 1.4 \times 10^{21}$ n/cm²)



12 instrumented specimens

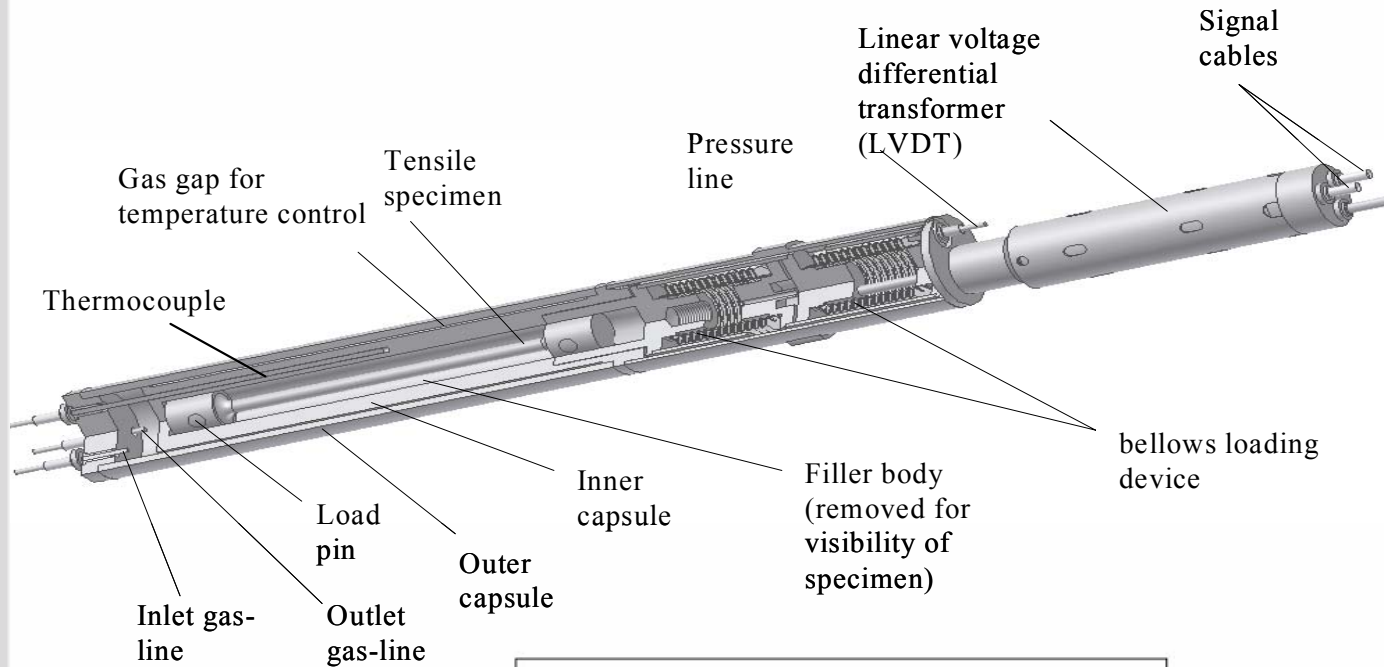

- gas lines for on-line temperature control alter He-Ar gas mixture
- LVDTs monitor sample elongation
- stress applied with bellows
- constant displacement maintained by reducing applied stress on-line by bellows pressure
- 2 instrumented samples operated in “creep-mode” (stress constant + displacement measured continuously)

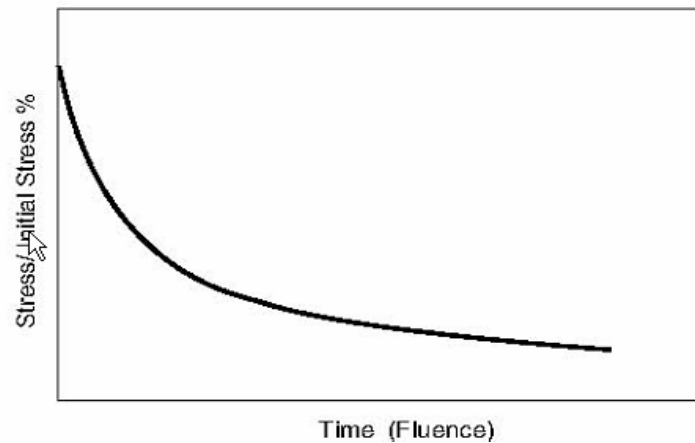

Test Matrix Instrumented Specimens IFA-669

Material	No.	Temp. (°C)	Stress (MPa)	Dose (dpa)	Comment
CW 316	1 +2*	330	345	2.0	Replacement baffle bolt + split pin matl
CW 316	1	330	275	2.0	* 2 specimens operated in creep mode
CW 316	1	330	205	2.0	
CW 316	1	330	----	2.0	Qualification sample
CW 316 LN	1	330	345	2.0	Low irradiation creep matl
CW 316 N lot	1	370	345	2.0	EBR II irradiation creep test archive
SA 304 L	1	290	90	2.0	EBR II irradiation creep test archive
SA 304 L	1	290	72	2.0	
Alloy 718	2	330	345	2.0	PWR irradiation stress relaxation data



Test Matrix, Uninstrumented Specimens IFA-669

Material	No.	Temp. (°C)	Stress (MPa)	Dose (dpa)	Comment
CW 316	2	330	275	0.4	Second phase ppt densification data
CW 316	2	330	275	1.6	
CW 316	2	330	275	2.0	
SA 304	2	290	90	0.4	Baffle former plate material
SA 304	2	290	90	1.6	
SA 304	2	290	90	2.0	
Alloy 718	2	330	345	0.4	Second phase ppt densification data
Alloy 718	2	330	345	1.6	
Alloy 718	2	330	345	2.0	



Loading configuration

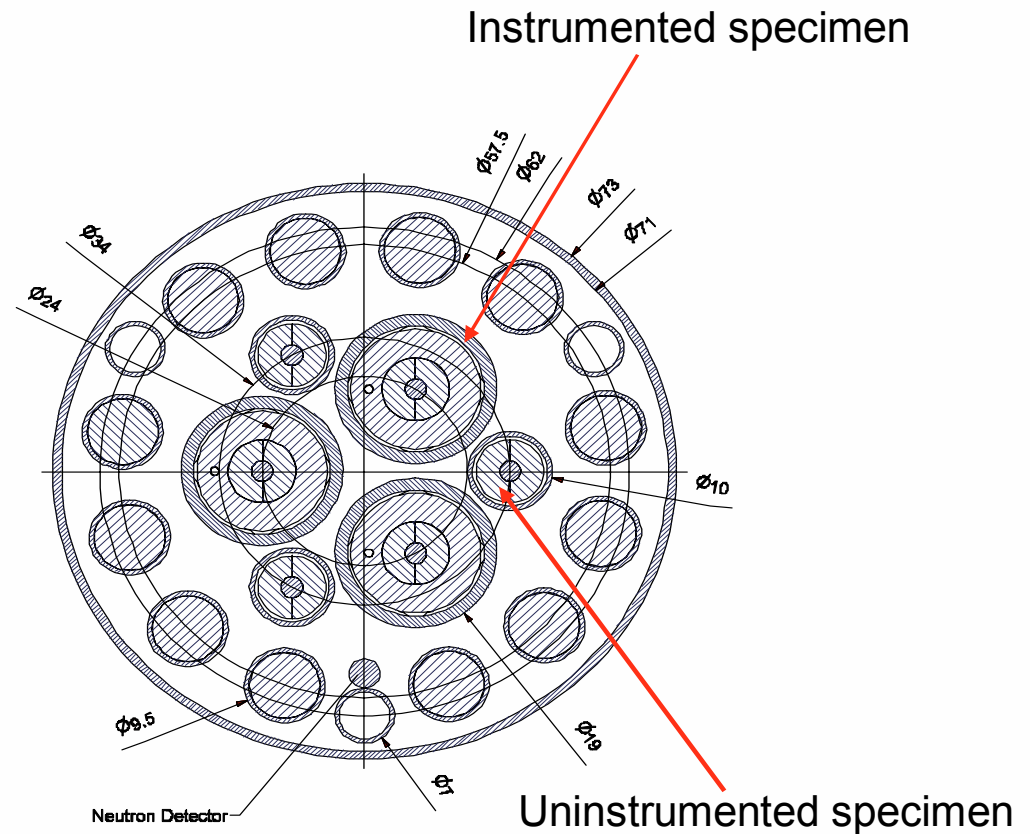
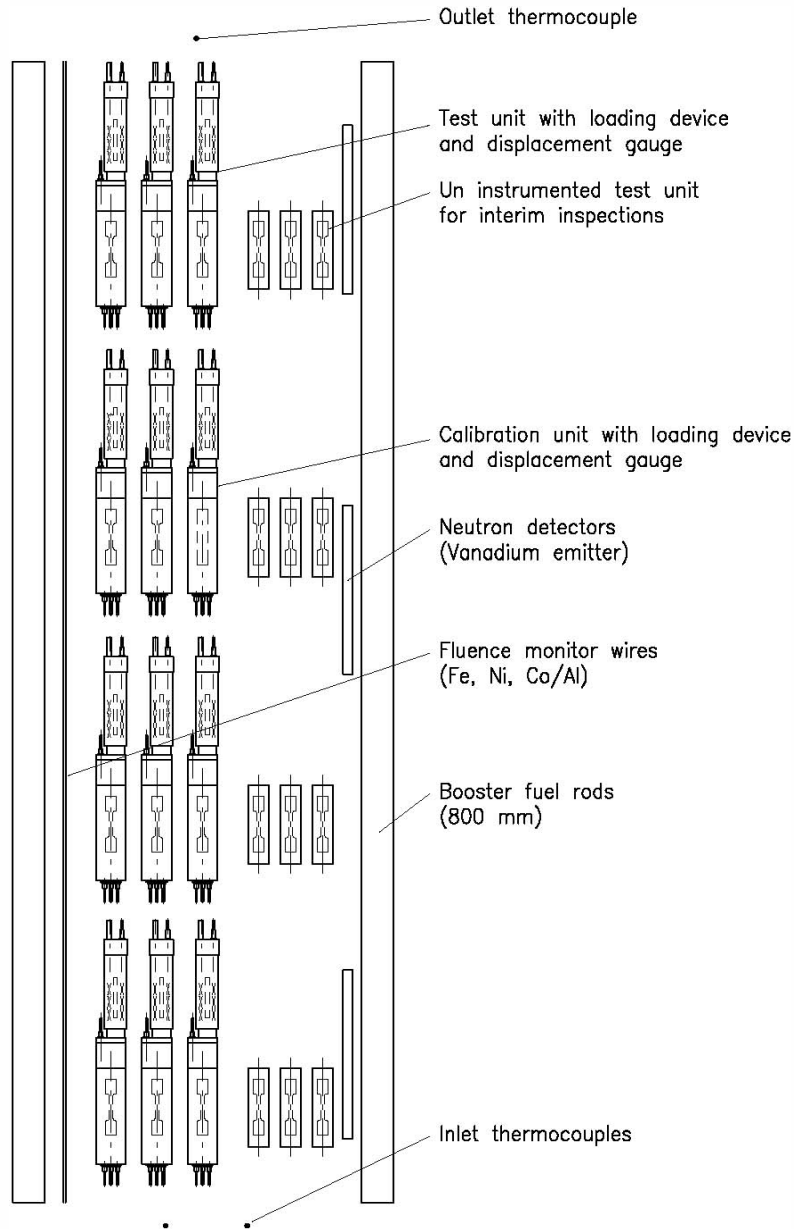

IFA-669 Pressure and Temperature Control System

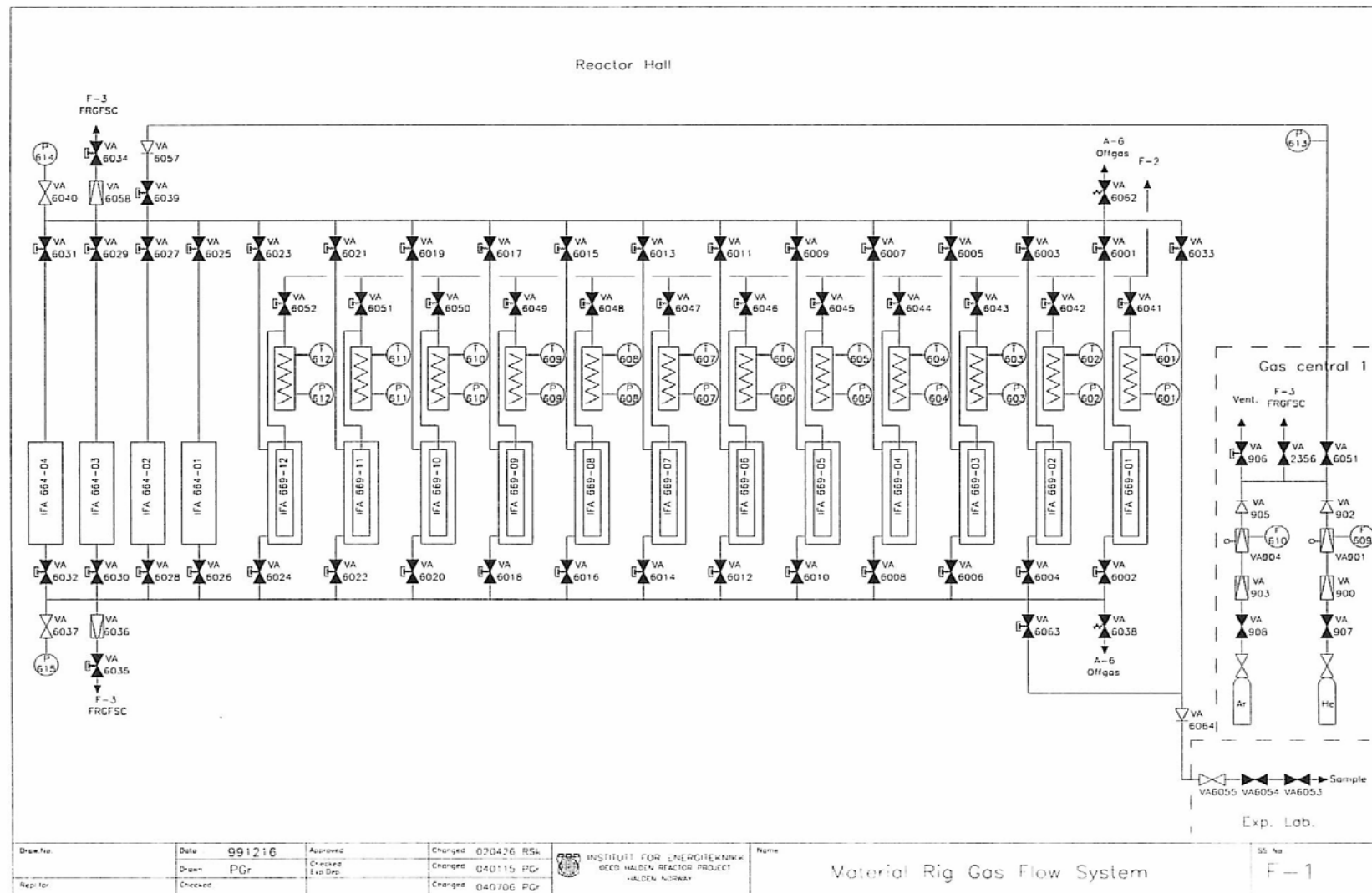

Contents (contd.)

4. Instrumentation development for materials studies
 - a. In-core conductivity cell
 - b. On-line potential drop corrosion monitor
 - c. Controlled distance electrochemistry measurements
 - d. Electrochemical impedance spectroscopy
 - e. ECP reference electrodes



Overview of instrumentation development for materials studies

- In-core conductivity cell
- On-line potential drop corrosion monitor
- Controlled distance electrochemistry measurements
- Electrochemical impedance spectroscopy
- ECP reference electrodes



In-core conductivity cell

- Based on Halden Pt in-core ECP reference electrode
- Pt sensing element surrounded by a second Pt cylinder. Additional signal cable fitted
- Apply current and determine conductivity from voltage difference between the 2 Pt cylinders
- Prototype sensors tested under PWR conditions, both in the Joint Programme (PWR IASCC test, IFA-657) and under bilateral projects
- Plans are to evaluate the sensor under BWR conditions
 - Low conductivity electrolyte



In-core conductivity cell

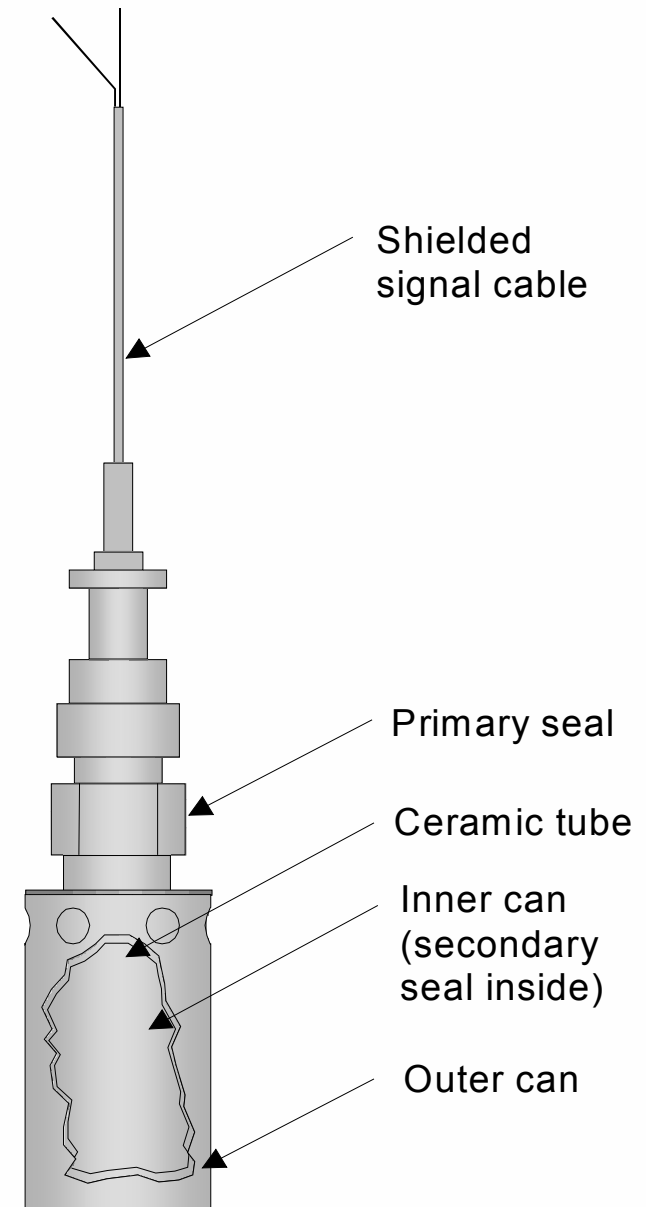

On-line potential drop corrosion monitor

- In-core corrosion of fuel cladding traditionally monitored by taking measurements during reactor shutdowns
- Can only determine average corrosion rates
- On-line corrosion monitor based on dc potential drop method developed for on-line crack growth measurements
- Attach current and potential wires to the end plugs of the fuel rod
- Apply current and measure resulting potential drop at different positions on the end plugs
- Relate potential drop to clad thickness through out-of-core calibration
- Accuracy $\pm 2 \mu\text{m}$
- A monitor is planned to be included in the new PWR clad corrosion test



Schematic of monitor

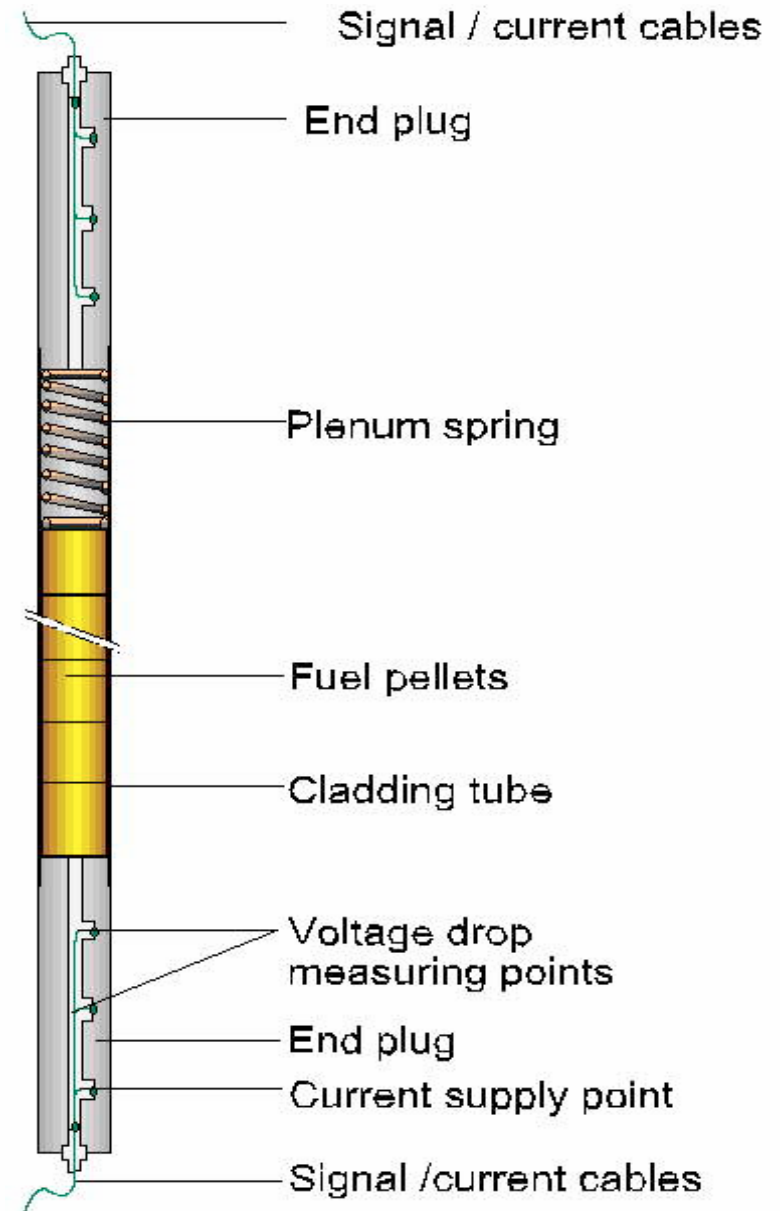

Controlled distance electrochemical techniques (CDE)

- Conventional electrochemical techniques have sample and counter electrode separated by a few mm / cm
- Conductivity of BWR coolant is too low for a current to flow
- CDE: reduce electrode separation to below 100 μm
- Development work performed by VTT: a bellows system has been developed to control electrode separation
- In-core testing to be performed at Halden



CDE - measurements

- Depending on electrode separation and applied electrical conditions (ac, dc), can investigate:
 - Electronic properties of oxide films
 - Oxidation / reduction kinetics
 - Release rate of soluble corrosion products



CDE - schematic

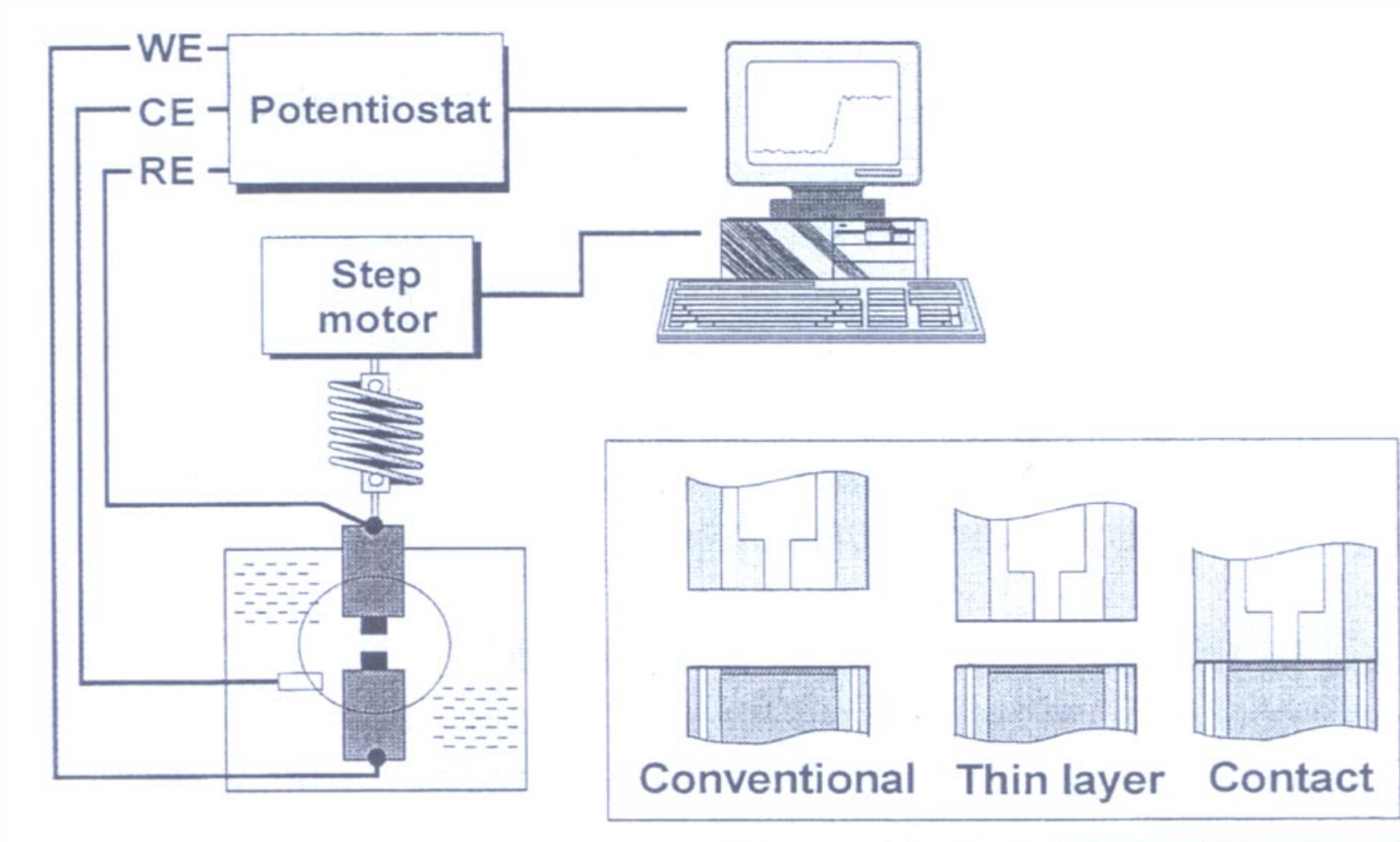

Electrochemical impedance spectroscopy (EIS)

- Used for on-line monitoring of oxide growth on Zircaloy fuel cladding or other reactor materials
- Apply a variable ac voltage to the sample and measure impedance with frequency of applied voltage
- Advantages of the technique:
 - Low perturbation signals that do not disturb system
 - Can be used in low conductivity media
 - Non destructive
- Calculate oxide thickness from an equivalent electrical circuit (capacitor with plate separation equal to oxide thickness)



EIS - development

- In the Joint programme, development work carried out by University of Gothenburg
- Work showed that long signal cables should not prevent data acquisition
- Test geometries: two-electrode configuration, with Zircaloy test and counter electrodes
 - Test electrode placed inside a concentric counter electrode
 - Identical electrodes placed alongside one another



EIS – development (contd.)

- Bilateral studies have shown that a more traditional three-electrode configuration gives better results:
 - Platinum mesh counter electrode, surrounding test electrode
 - Platinum reference electrode
- Length of signal cables minimised, by locating potentiostats and computers to run the tests in the reactor hall
- Measurements can be controlled by remote access to these computers



ECP reference electrode development

- Electrochemical corrosion potential (ECP) is the potential difference between a sample and the standard hydrogen electrode (SHE).
- ECP is an indirect measurement of the potential across the metal-solution boundary, and thus of the driving force for corrosion.
- ECP measured mainly in BWRs:
 - SCC of sensitised stainless steel significantly reduced below –
 $230 \text{ mV}_{\text{SHE}}$
⇒ hydrogen water chemistry, noble metal addition
- In-core ECP measurements allow link-up with R&D work



Measurement of ECP

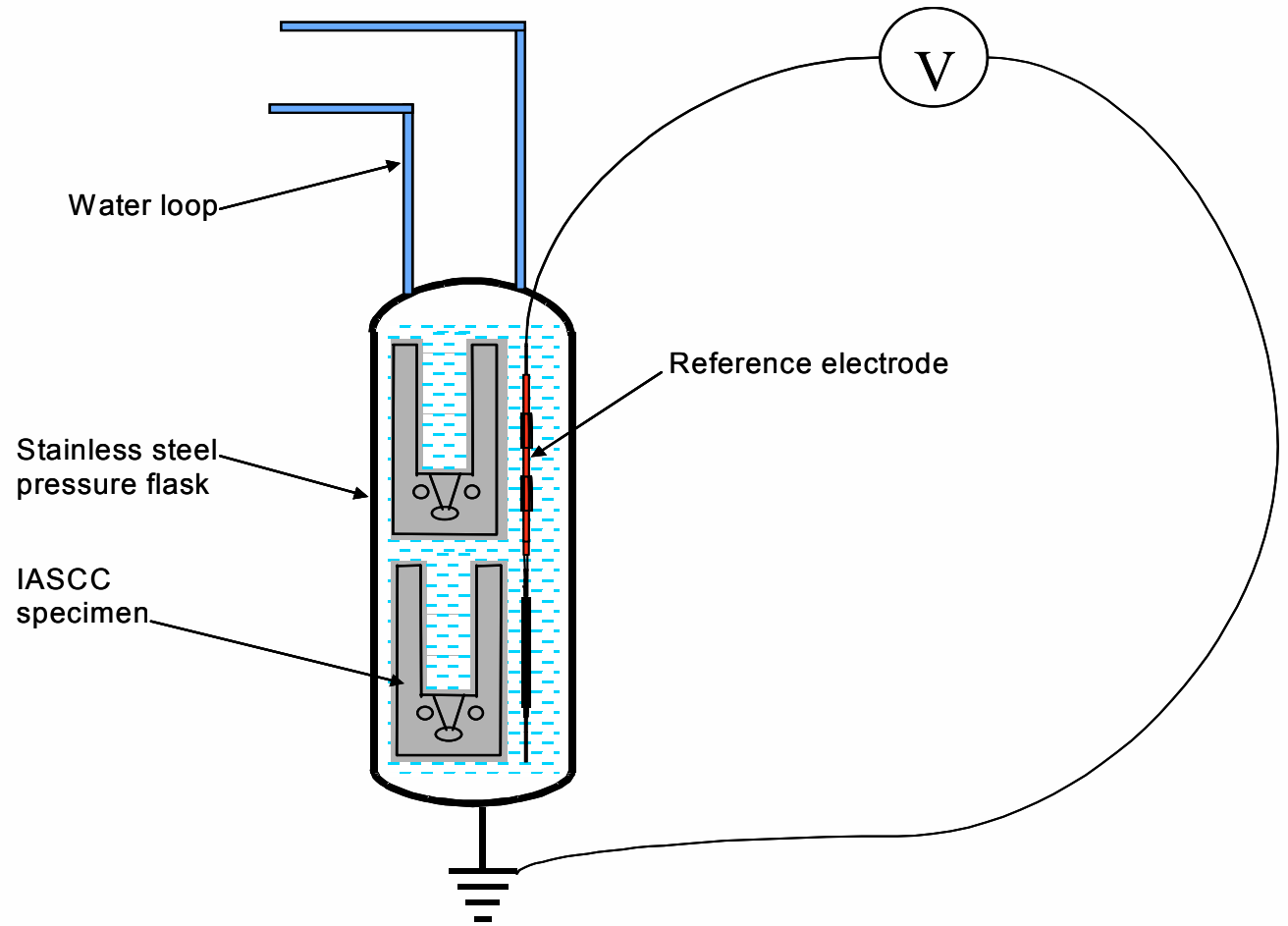

$$\text{ECP (stainless steel)}_{\text{SHE}} = \text{V} + \text{V (ref)}_{\text{SHE}}$$



ECP reference electrodes: development

- Halden platinum electrode is reliable, but Pt electrodes do not give SHE values in oxygenated water
- Palladium electrode shows promise for use in oxygenated water (IFA-658). Further testing and calibration is required.
- For reliable ECP measurements, two different reference electrode types should be used. Fe/Fe₃O₄ electrodes can be used in both hydrogenated and oxygenated water.
- A prototype Fe/Fe₃O₄ electrode has been constructed and tested. The electrode seal was leaktight during 3 temperature cycles.
- In-core testing planned in the BWR IASCC experiment, IFA-670



Fe/Fe₃O₄ electrode

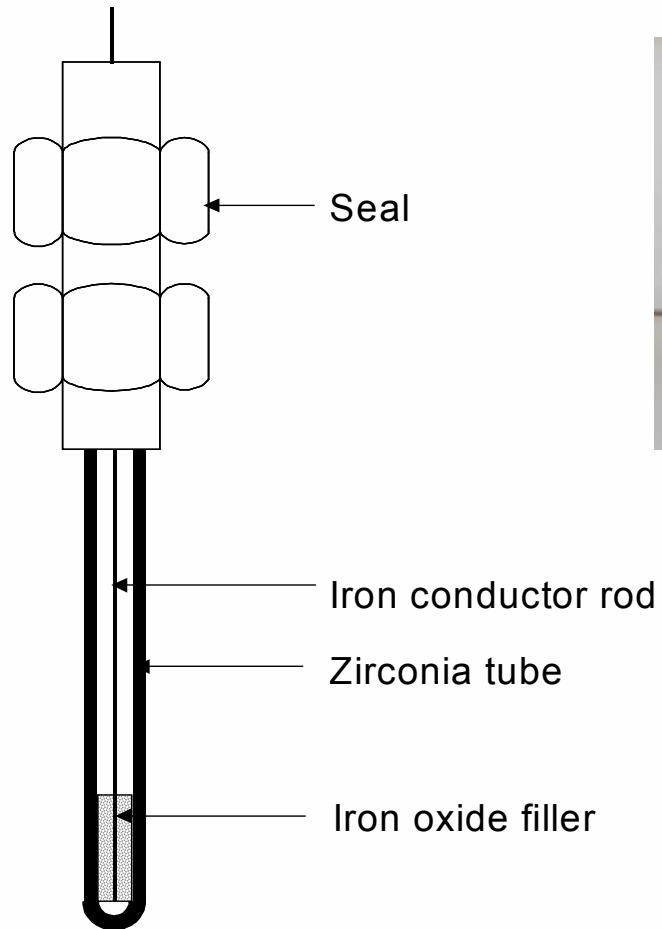

Pt electrode, mounted in rig



Pd electrode



Summary

Well-qualified in-core measurement data from test reactors are valuable and:

- supplement LTA programmes (and PIE campaigns)
- supplement out-of-pile studies (on separate effects)
- enhance the understanding of basic mechanisms affecting fuel & materials behaviour
- provide basis for detailed modelling of steady state and transient behaviour of LWR fuel





That's all we had time for, folks! THE
END

