



**The Abdus Salam
International Centre for Theoretical Physics**



1858-2

**School on Physics, Technology and Applications of Accelerator Driven
Systems (ADS)**

19 - 30 November 2007

**Engineering Design of the MYRRHA.
Part II**

Didier DE BRUYN
*Myrrha Project Coordinator
Nuclear Research Division
SCK CEN
BE-2400 Mol (Belgium)*

MYRRHA – Draft 2 Fuel Pins & Fuel Assembly Pre-Design

Vitaly Sobolev & Hamid Aït Abderrahim

On behalf of MYRRHA team and MYRRHA support

<http://www.sckcen.be/myrrha>

CONTENTS



1. General approach to fuel design
2. Determination of fuel pellet sizes
3. Cladding sizes
4. Pre-design of a whole fuel pin
5. Pre-design of a fuel assembly
6. Preliminary estimation of the fuel operation parameters
7. Items still under consideration
8. Conclusions

1. General approach to fuel design (1)



Needed input information:

- core (spectrum, total power, power density or neutron flux);
- fuel type (oxide, metal, cermet, ...);
- initial fuel enrichment, composition and density;
- aimed fuel burn-up;
- coolant type (liquid metal, gas, ...);
- allowed coolant temperature and flow velocity;
- cladding material;
- allowed cladding temperature, corrosion; stresses and strains.

1. General approach to fuel design (2)



Core parameters choice :

- Neutron spectrum -> fast
- k_{eff} -> ~ 0.95
- Total power -> ~ 50 MW(th)
- Fast neutron flux -> $\sim 10^{15}$ cm⁻² s⁻¹
(fuel power density -> ~ 1.5 kW cm⁻³)

1. General approach to fuel design (3)



Fuel choice:

- Fuel type → oxide → MOX;
- Composition and density → (Pu,U)O₂ of 95 % TD
- Initial enrichment → 20-30 % Pu (PWR) in HM
- Aimed (peak) burn-up → ~ 100 MWd/kg iHM
- Maximum allowed temperature → $0.9 T_m \sim 2100-2400 \text{ }^\circ\text{C}$

1. General approach to fuel design (4)



Fuel choice:

- Pu isotopic vector:

Isotope	Content, wt.%
^{238}Pu	1.27
^{239}Pu	61.88
^{240}Pu	23.50
^{241}Pu	8.95
^{242}Pu	4.40

... however, the MOX is in disagreement with RERTR program ?

1. General approach to fuel design (5)



Coolant parameters choice:

- coolant type → LBE ($T_m = 124\text{ °C}$)
- allowed temperatures → from 200 °C up to 450 °C
- allowed flow velocity → 2 m s^{-1}

... however, the lower temperature limit should (may be) increased because of the clad embrittlement problems ..

1. General approach to fuel design (6)



Clad material requirements:

1. Keeping the adequate mechanical performances (strength, ductility, swelling, creep) at high doses and operation temperatures.
2. Resistance to corrosion-erosion attack of LBE flow
3. Resistance to cycling stresses caused by the trips and restarts of the proton beam.

→ *ferrite-martensitic or austenitic steels ?*

1. General approach to fuel design (6)



Comparison of austenitic and ferrite-martensitic steels

Swelling

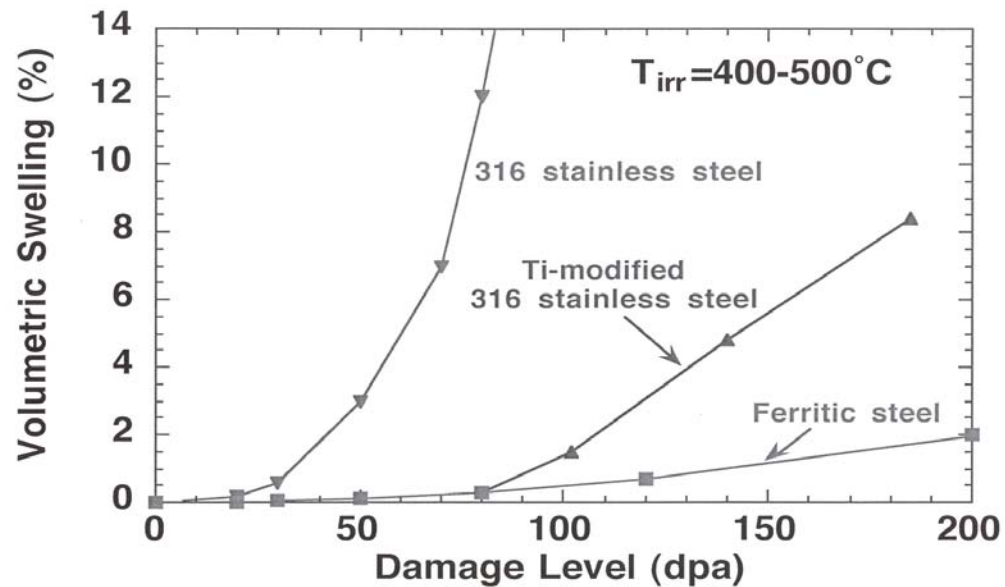

Oxidation

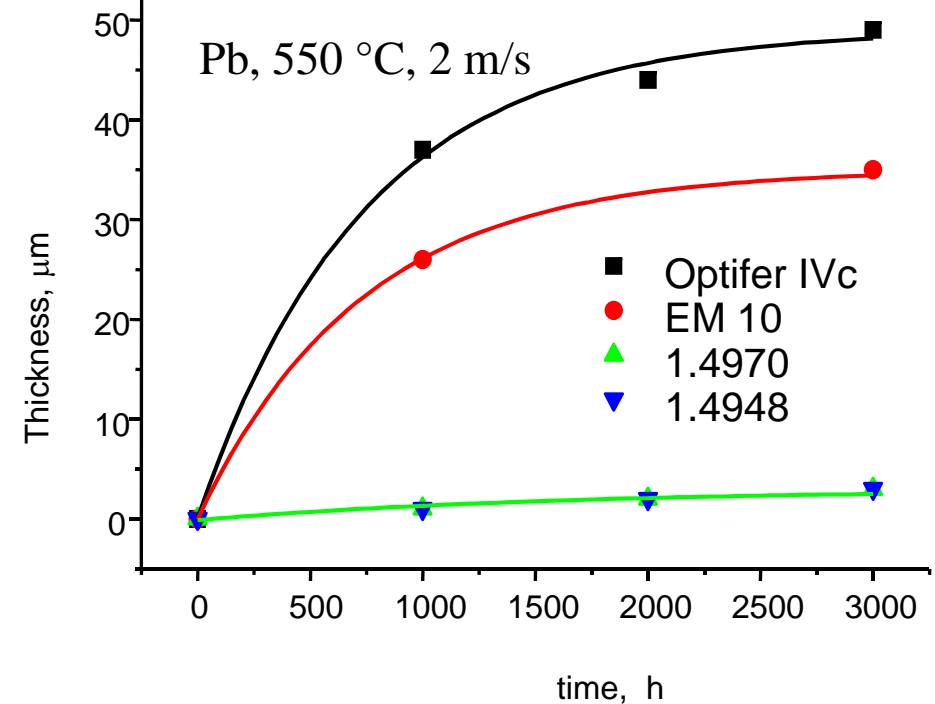

1. General approach to fuel design (7)



Embrittlement of Cr-steels

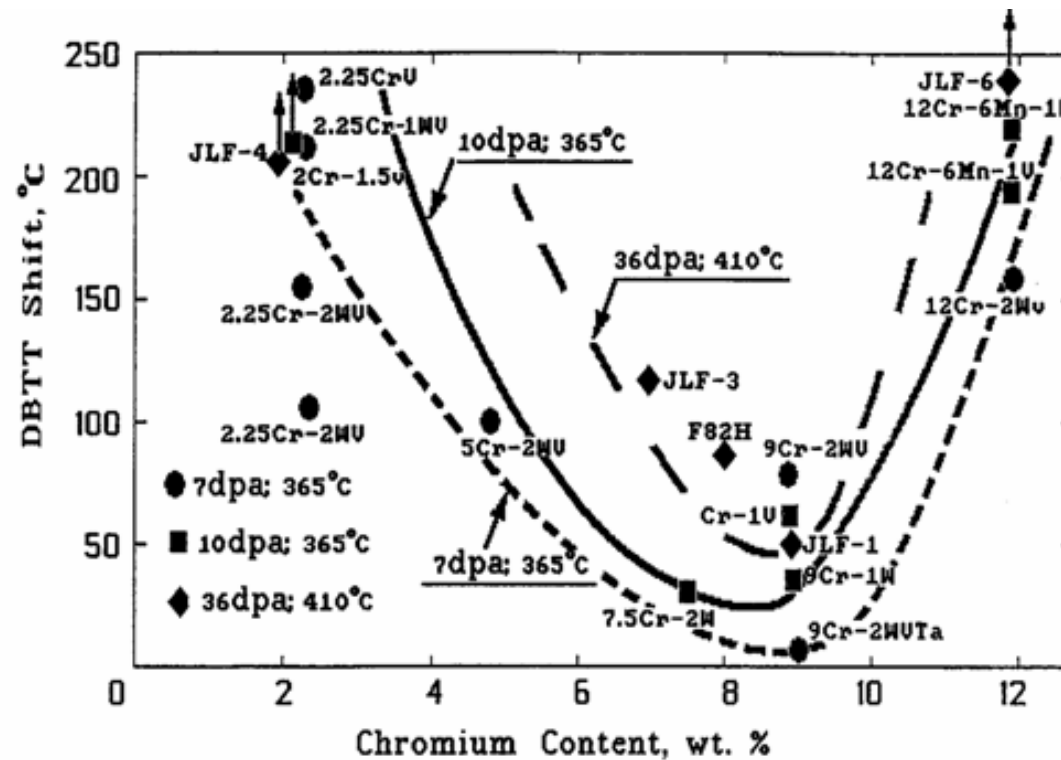

1. General approach to fuel design (8)



Cladding parameters choice:

- Material → T91 MS (oxygen protection)
- Allowed temperature → 500 °C (normal operation)
600 °C (transients)
- Allowed radiation damage → ~100 dpa
- Allowed swelling → ~ 5 %
- Allowed corrosion → ~ 10 %

*SS 316 Ti (corrosion protected) is still kept as back-up solution.
...however, helium induced embrittlement can be a problem...*

1. General approach to fuel design (8a)



Creep Rupture Life of 20% Cold-worked Type 316 Stainless Steel at 550°C, 310 MPa

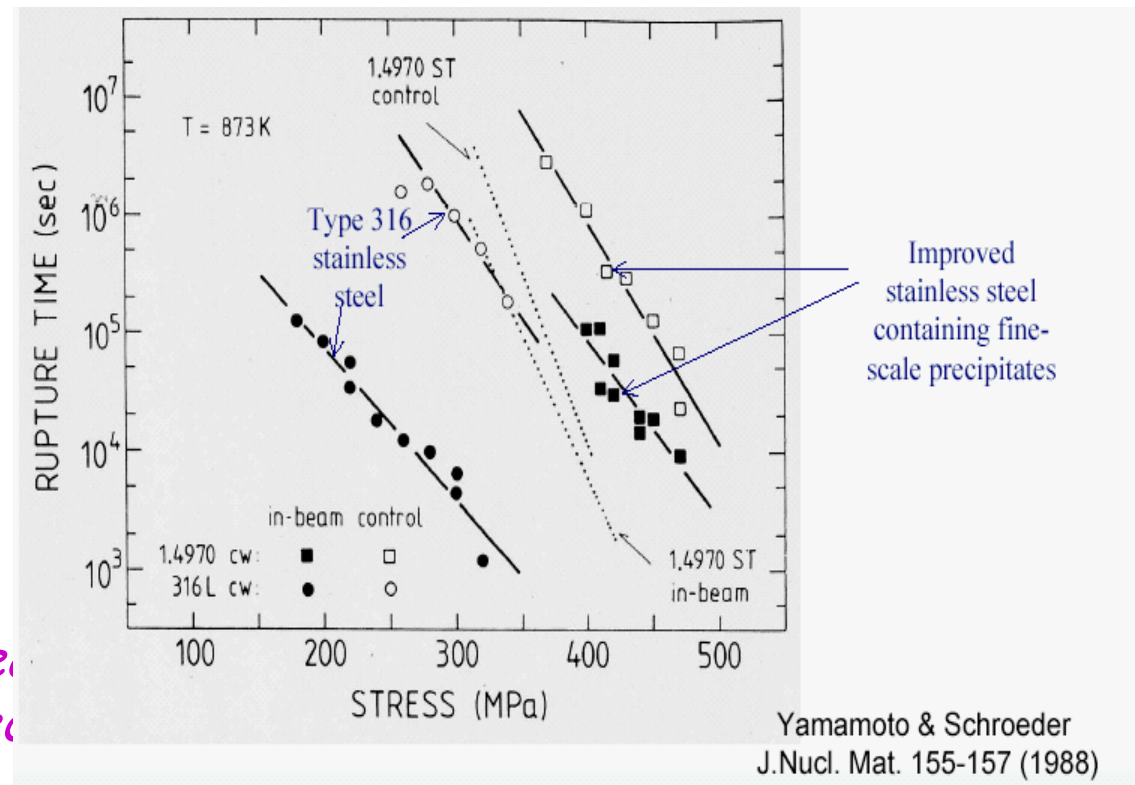
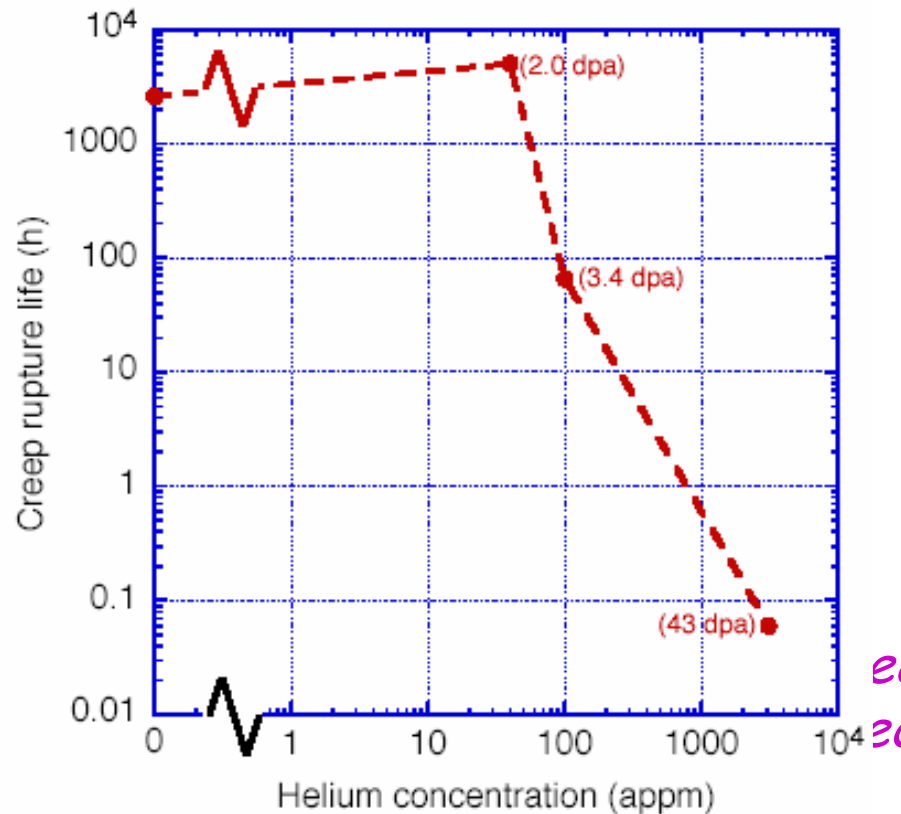

1. General approach to fuel design (9)



Main steps in the fuel rod pre-design:

- Fuel pellet sizes
- Clad diameter and thickness
- Fuel column and gas plenum
- Preliminary design of a whole rod
- Design test with fuel performance codes
- Design optimisation

2. Determination of fuel pellet sizes (1)

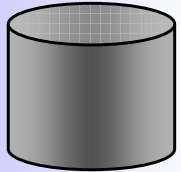

- Pellets without hole to simplify fabrication.
- Pellet diameter to satisfy the fuel non-melting conditions:

$$T_{melt} < T_{fuel\ max} = T_{cool} + \frac{\pi \cdot d_{pellet}^2 \cdot q_{v\ max}}{4} \cdot (\mathcal{R}_{cool} + \mathcal{R}_{clad} + \mathcal{R}_{gap} + \mathcal{R}_{pellet})$$

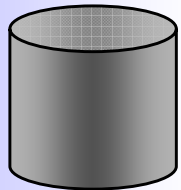

- $q_{v\ max} \sim 1.5\ kW/cm^3$ to obtain $\Phi_{fast} \sim 10^{15}\ cm^{-2}\ s^{-1}$
- Safety margin $T_{fuel\ max} = 0.9\ T_{melt}$

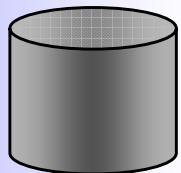

2. Determination of fuel pellet sizes (2)



Safety margins for fuel temperature

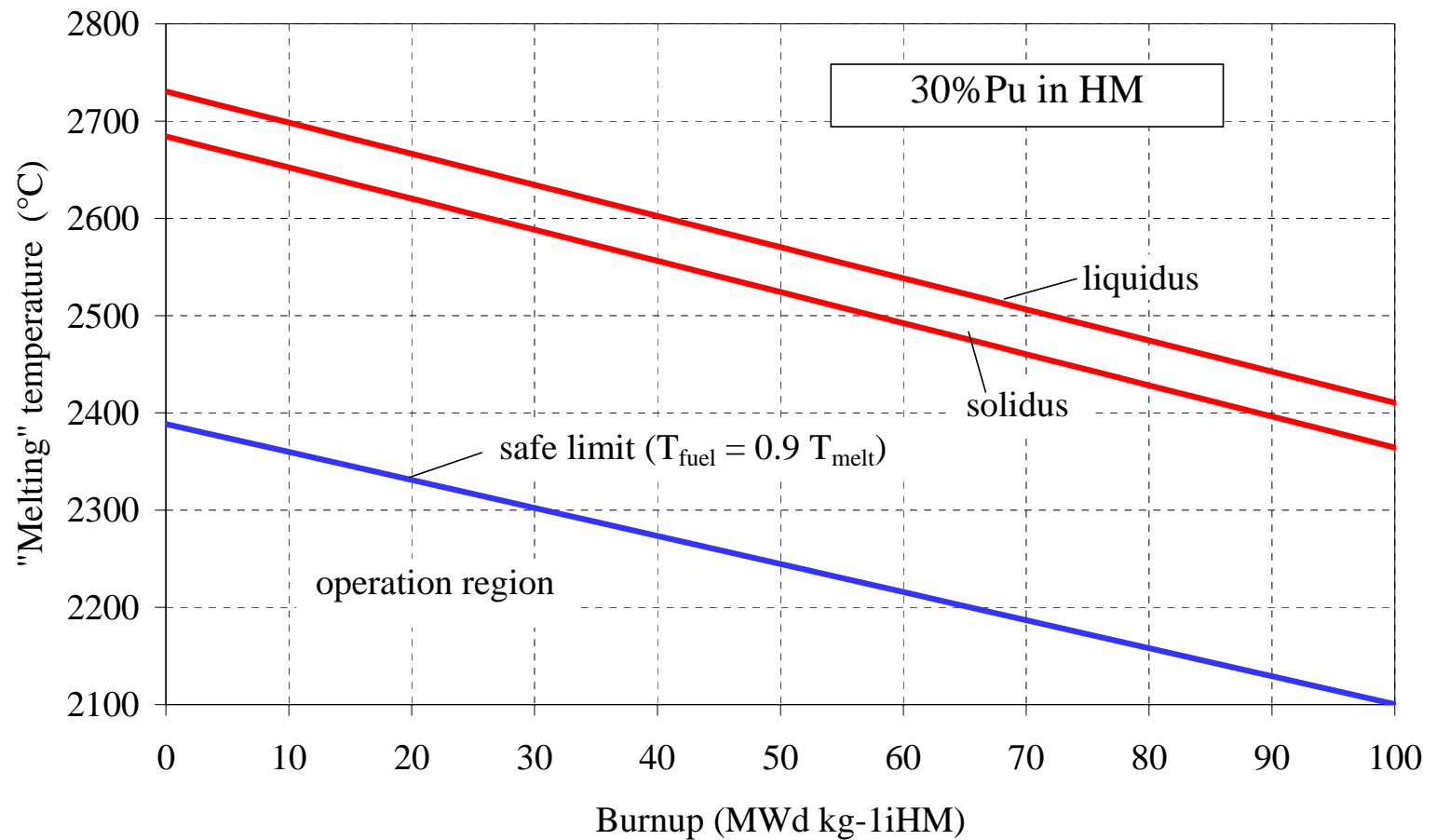
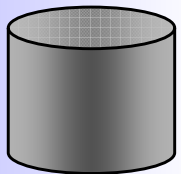
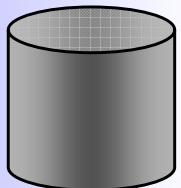
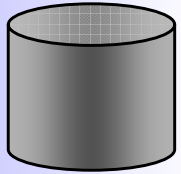

2. Determination of fuel pellet sizes (3)

Fuel thermal conductivity degradation

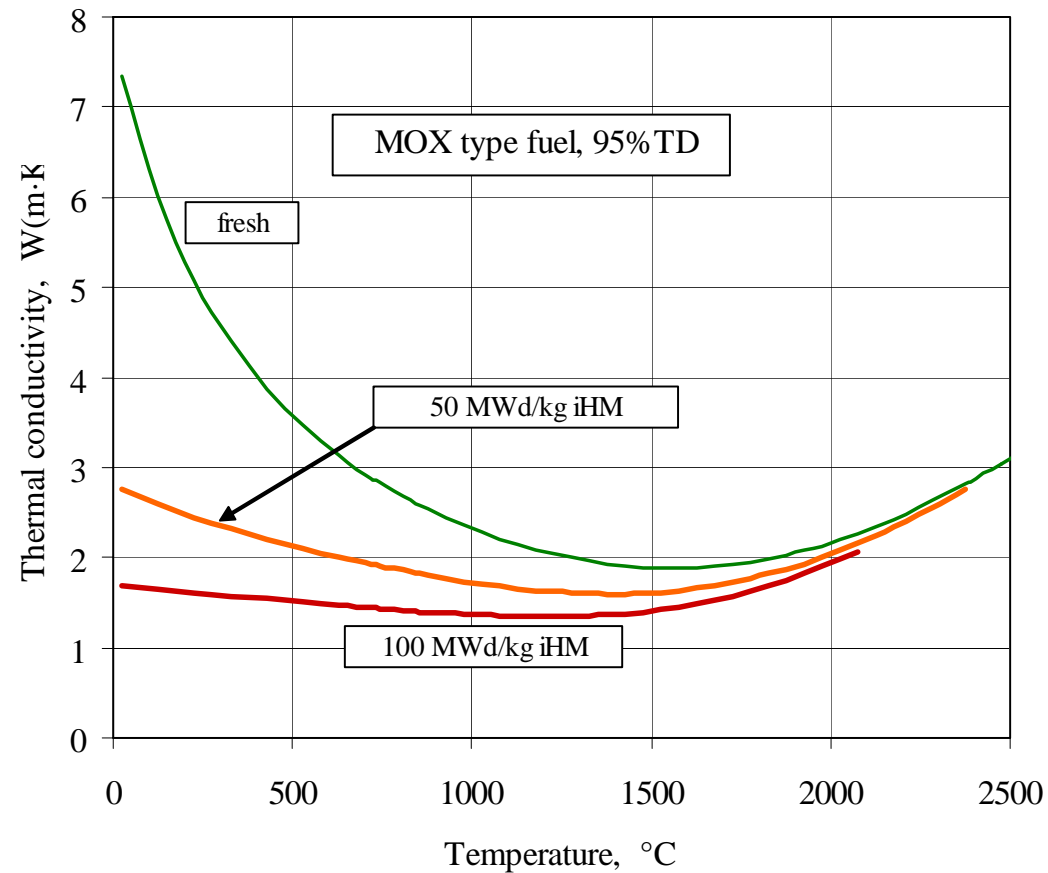
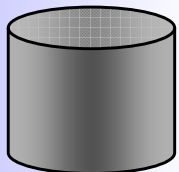
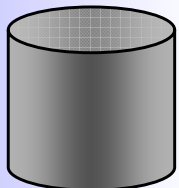
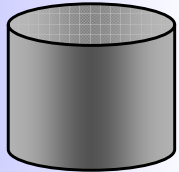

2. Determination of fuel pellet sizes (4)



Radial thermal resistivity of fuel rod

$$T_{melt} < T_{fuel\ max} = T_{cool} + \frac{\pi \cdot d_{pellet}^2 \cdot q_{v\ max}}{4} \cdot (\mathcal{R}_{cool} + \mathcal{R}_{clad} + \mathcal{R}_{gap} + \mathcal{R}_{pellet})$$

<i>Pellet type</i>	<i>Time</i>	\mathcal{R}_{cool}	\mathcal{R}_{clad}	\mathcal{R}_{gap}	\mathcal{R}_{pellet}	$q_v\ max$	T_{max}	T_{cool}	$D_{pellet\ max}$
		K·m/kW	K·m/kW	K·m/kW	K·m/kW	kW/cm ³	°C	°C	mm
<i>Solid</i>	<i>BOL</i>	2.38	1.13	22.4	35.0	1.5	2390	300	5.40
<i>Solid</i>	<i>EOL</i>	2.38	1.18	0.25	53.0	1.2	2100	300	5.80

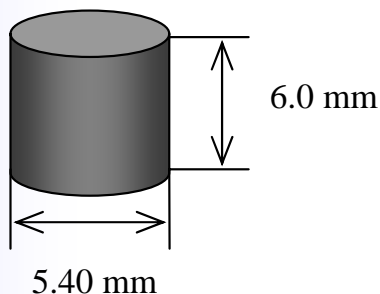

- *The chosen pellet : \varnothing 5.40 x 6.0 mm ($q_v = 1.5\ W/cm^3 \sim q_l = 350\ W\ cm^{-1}$).*
- *...however, it would be better to use the pellets with the same sizes as in the developed LMFR (SNR, Phenix, ...)*

3. Cladding sizes

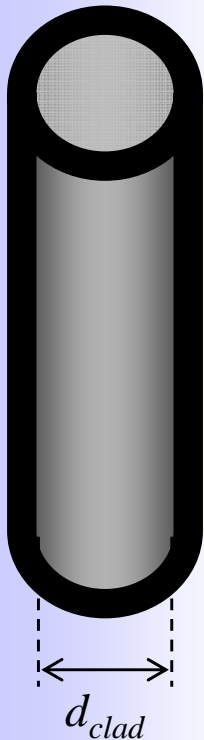

- Clad inner diameter:
 - Gap is to avoid or reduce PCMI
 - Gap thickness δ_{gap} should compensate:
 - ♣ fuel thermal expansion
 - ♣ fuel irradiation induced swelling (~1.6vol.% per 10 MWd kg⁻¹iHM)
 - Inner clad diameter: $d_{clad} = D_{pellet} + \delta_{gap}$

δ_{gap} (radial) = 75 microns and $d_{clad} = 5.55$ mm have been obtained as the first estimate.

3. Cladding sizes



Liner thermal dilatation of MOX, SS 316 and FMS T91

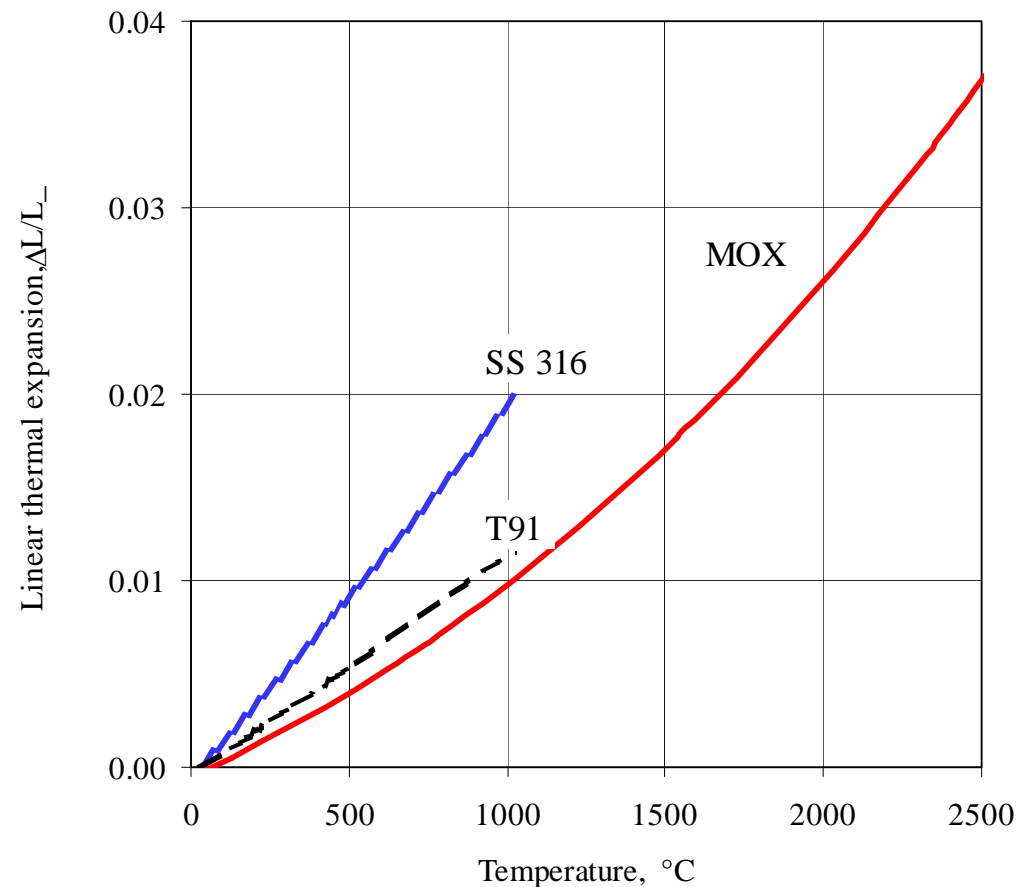

3. Cladding sizes

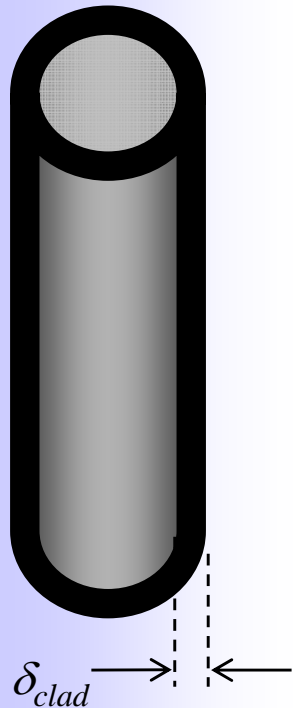

Clad thickness is chosen to withstand:

- intrinsic thermal expansion stresses
- pressure of inside gases
- pressure of outside coolant
- inside corrosion attack of fission products
- outside corrosion attack of LBE coolant
- fatigue initiated by power changes caused by the proton beam trips and restarts.
- PCMI -> for ASS < (0.4-1)% plastic deformation
for FMS ...?

3. Cladding sizes

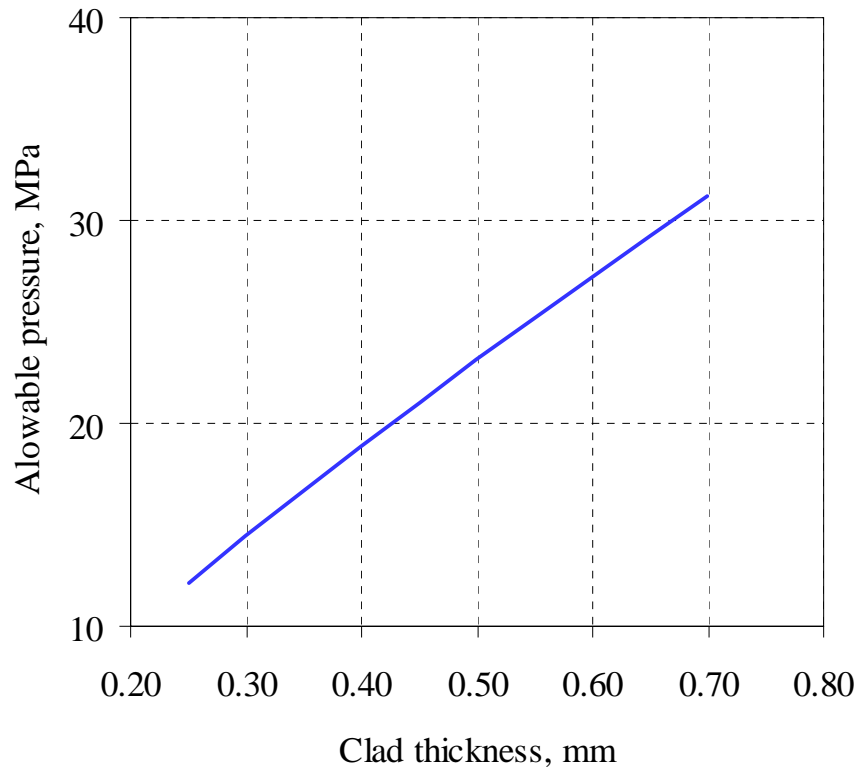
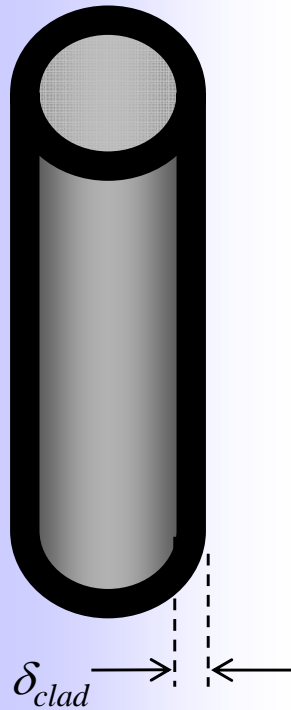

$$p_{\max} = \frac{[\sigma] \cdot \delta_{clad}}{0.5 \cdot D_{clad \text{ inside}} + 0.6 \cdot \delta_{clad}}$$

$$[\sigma] = \min\{\sigma_{uts} / 2.6; \sigma_{0.2} / 1.5\}$$

$\delta_{clad} = 0.5 \text{ mm}$ obtained as the first estimate ($p_{\max} = 23 \text{ MPa}$).

...however cladding sizes should still be optimised after determination of T91 properties at representative irradiation conditions.

4. Whole rod pre-design (1)



Fuel column length

- Compact core $\rightarrow L_{\text{active zone}} \sim D_{\text{active zone}}$
- Limited axial form factor $\rightarrow 1.2-1.3$
- Neutronic estimates $\rightarrow L_{\text{fuel}} \approx 600 \text{ mm}$

Reflector segments

- Neutronic estimates $\rightarrow I_{\text{ref}} = 50-100 \text{ mm}$
- Material $\rightarrow \text{YSZ}$

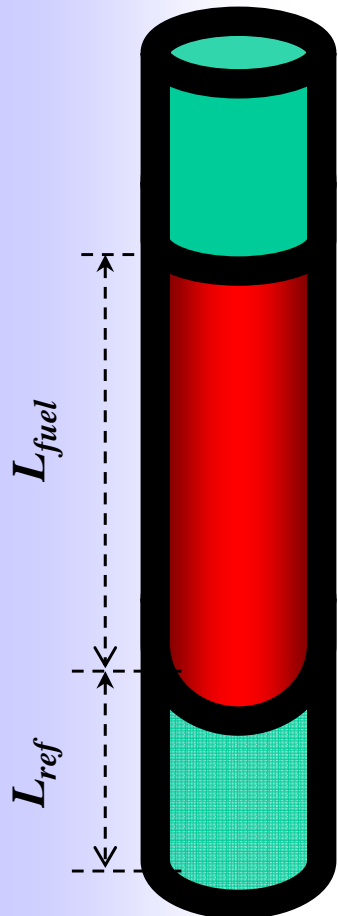

4. Whole rod pre-design (2)

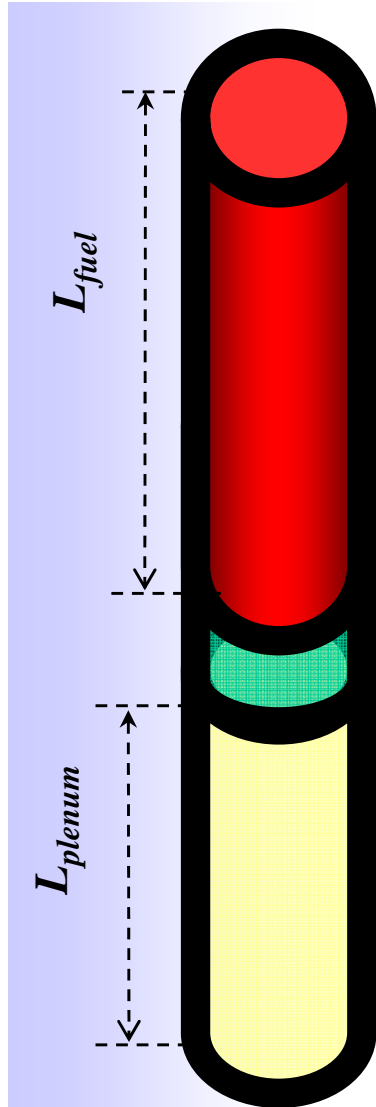

Gas plenum volume is determined:

- by the released amount of fission gas (production rate $\sim 115 \text{ mole m}^{-3}$ per $10 \text{ MWd kg}^{-1}\text{iHM}$)
- by the gas temperature in plenum
- by the cladding mechanical resistance

$$P_{tot} = \frac{p_{0\text{He}} \cdot T_{gas}}{T_0} + \frac{R \cdot \eta_{FG} \cdot Bu \cdot \rho_{fuel} \cdot V_{fuel} \cdot T_{gas}}{\rho_{TD\text{fuel}} \cdot V_{plenum}} < P_{max}$$

Temperature of gas is a critical parameter which is difficult to determine, especially, in the case of a rapid (burst) gas release.

$$L_{plenum} = 60 + 300 = 360 \text{ mm was chosen}$$

4. Whole rod pre-design (3)

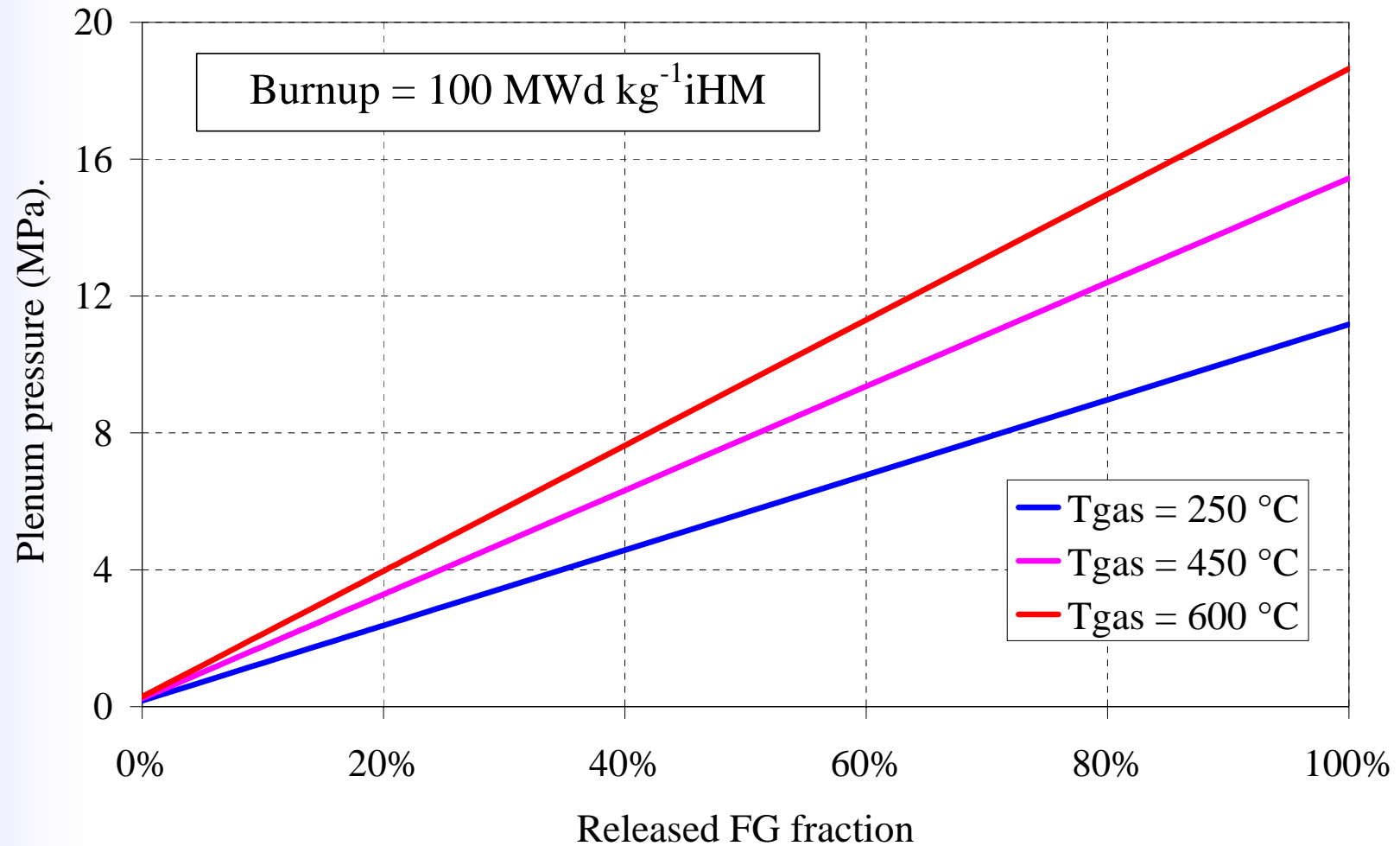

4. Whole rod pre-design (4) Axial schematics

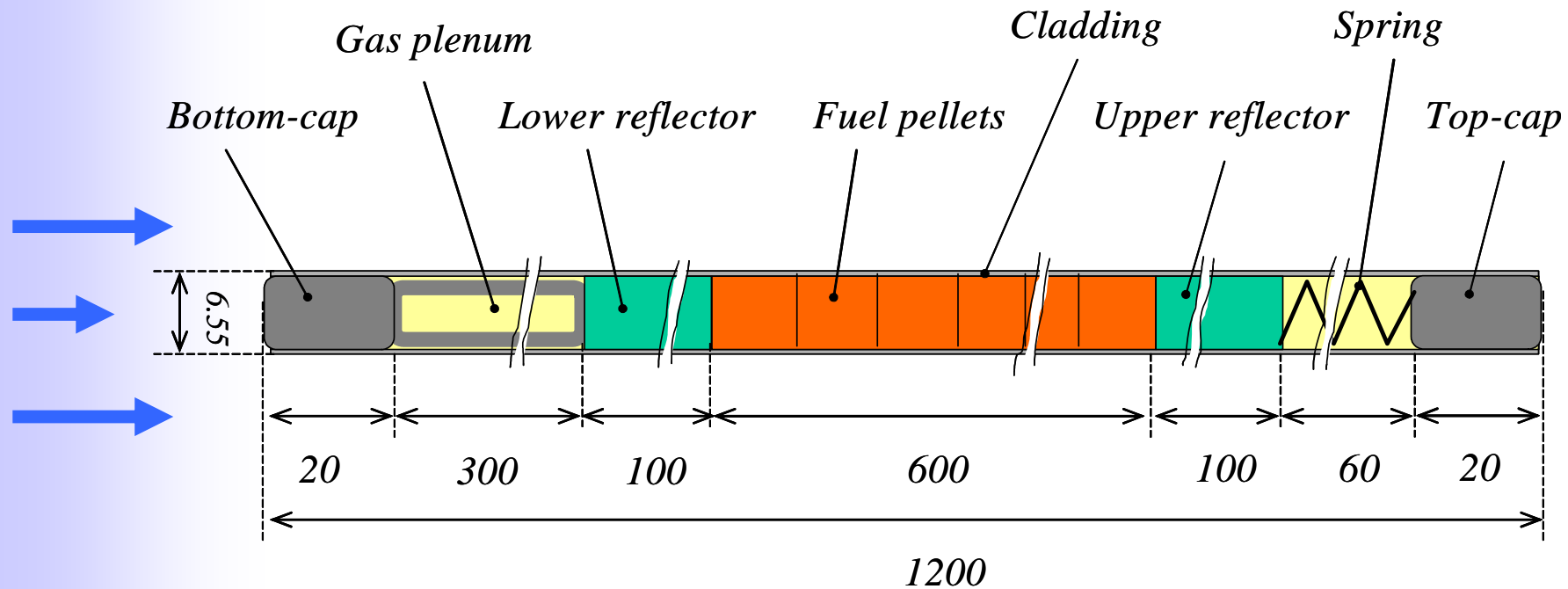

A typical design of LMFR rod has been adapted to the MYRRHA specific conditions.

4. Whole rod pre-design (5)



Table 5. Main geometrical parameters (*in mm*) of the fuel pins of some fast neutron reactors and of ADS MYRRHA.

	SPX	Phenix	SNR-300	BN-600*	EFR	MYRRHA
Diameter	8.50	6.55	6.00	6.90	8.65	6.55
Total length	2700	1793	2475	1100	3600	1200
upper gas-plenum	162	93	50	20	1700	60
upper breeder/reflector	300	(0)**	400	50	250	100
active part	850	900	950	500	1400	600
lower breeder/reflector	300	(300)**	400	50	150	100
lower gas-plenum	852	442	650	421	545	300

* experimental fuel rod with the holed pellets;

** special design.

5. Pre-design of a fuel assembly (1)



Main steps in the fuel assembly design:

- 1) Fuel micro-cell (type and pitch)
- 2) Assembly radial cross-section
- 3) Assembly axial schematics
- 4) Preliminary design of a whole assembly
- 5) Modelling with suitable thermohydraulic and thermomechanical codes
- 6) Optimisation

5. Pre-design of a fuel assembly (2)



Microcell = fuel rod + coolant + spacer
Microcell type \rightarrow hexagon or triangle

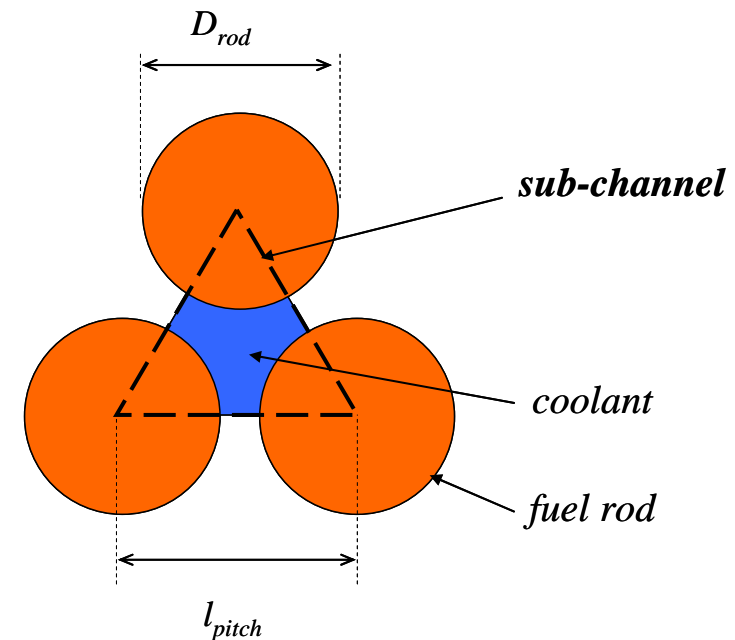
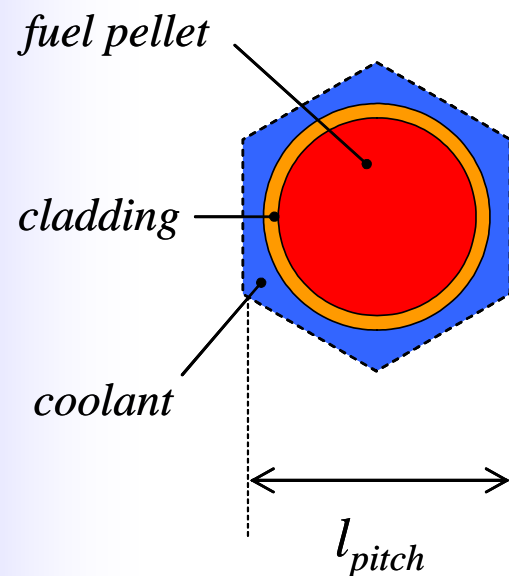

Pitch (l_{pitch}) ? \rightarrow heat balance + pressure drop + fuel fraction

5. Pre-design of a fuel assembly (3)



Heat balance \rightarrow pitch = f (Q_{rod} , $\Delta T < 200^\circ\text{C}$, $v_{cool} < 2 \text{ m/s}$)

$$Q_{sch} = \langle \rho_{cool} \cdot c_{p\ cool} \rangle \cdot \Delta T_{cool} \cdot v_{cool} \cdot S_{cool}$$

$$x_{pitch} \equiv \frac{l_{pitch}}{D_{clad}} \geq \sqrt{\frac{\pi}{2\sqrt{3}} \cdot \left(1 + \frac{4 \cdot \langle q_{l\ rod} \rangle \cdot l_{fuel}}{\pi \cdot D_{clad}^2 \cdot \rho_{cool} \cdot v_{cool} \cdot \langle c_{p\ cool} \rangle \cdot \Delta T_{cool}} \right)}$$

$$x_{pitch} \geq 1.224 \quad \rightarrow \quad l_{pitch} \geq 8.02 \text{ mm}$$

5. Pre-design of a fuel assembly (4)



Pressure drop \rightarrow pitch = f ($\Delta p < 2$ bar, $v_{cool} < 2$ m/s)

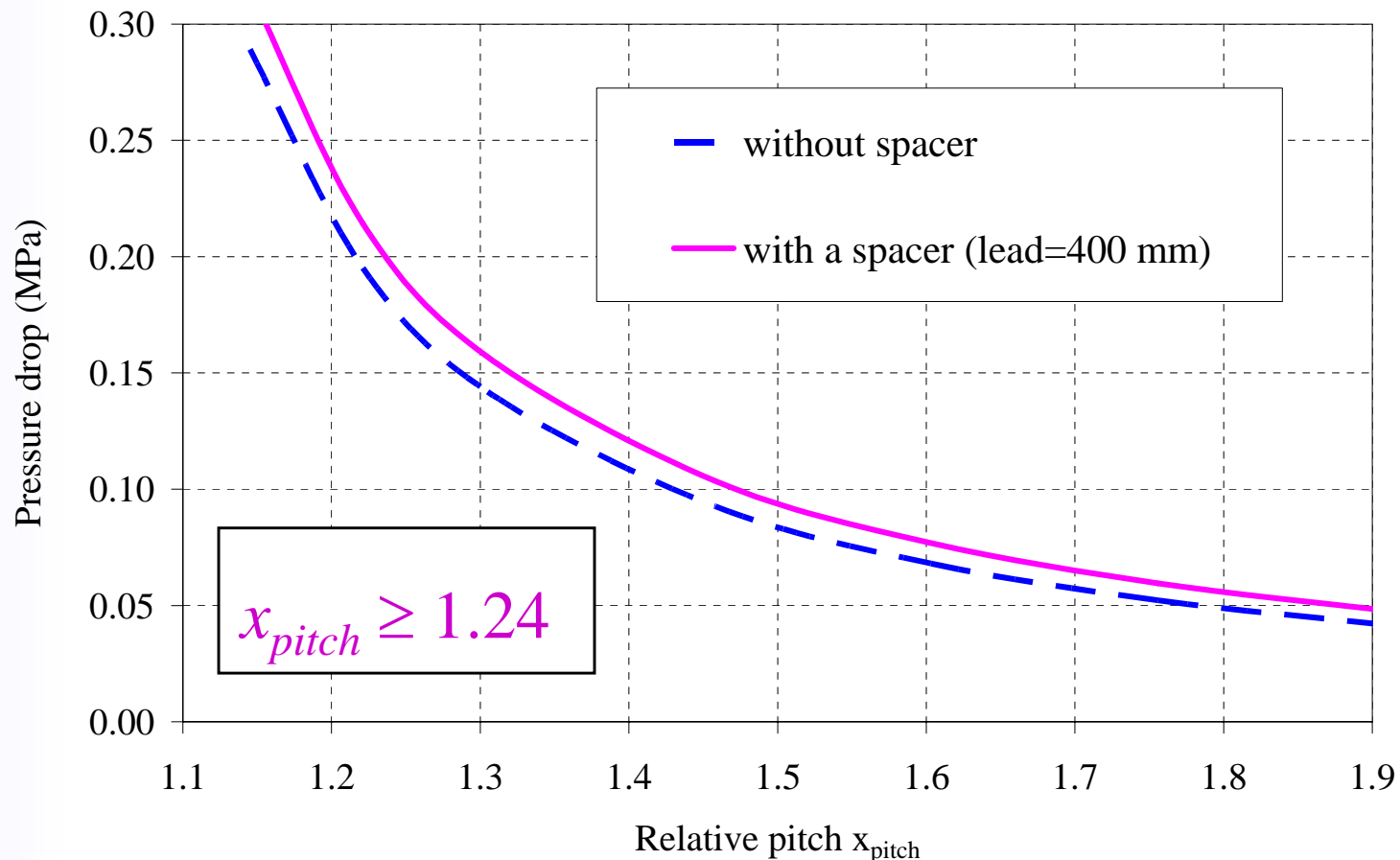

5. Pre-design of a fuel assembly (5)



Fuel fraction →

pitch = f (minimum coolant fraction to obtain $k_{eff} \sim 0.95$)

$x_{pitch} = 1.305 \rightarrow l_{pitch} = 8.55$ mm was chosen at this stage of the pre-design.

...however, a large value is preferable for natural circulation build-up in the case of a pump trip.

5. Pre-design of a fuel assembly (6)

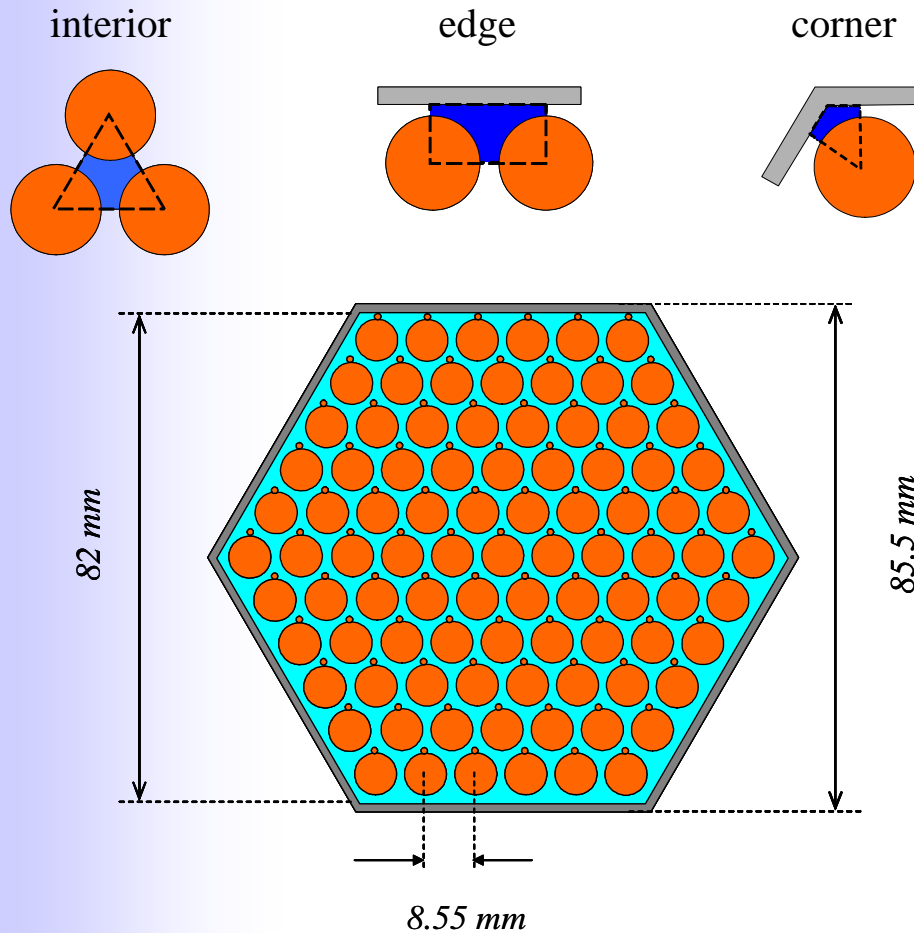

Radial cross-section design:

1. Edge and corner sub-channels optimisation
2. Determination of a number of rods in FA →
Radial gradient limits.
4. Shroud thickness →
"bowing", "deflection" ?
5. Bundle grids and other elements.
6. Thermohydraulic and thermomechanical modelling
7. Optimisation

5. Pre-design of a fuel assembly (7)

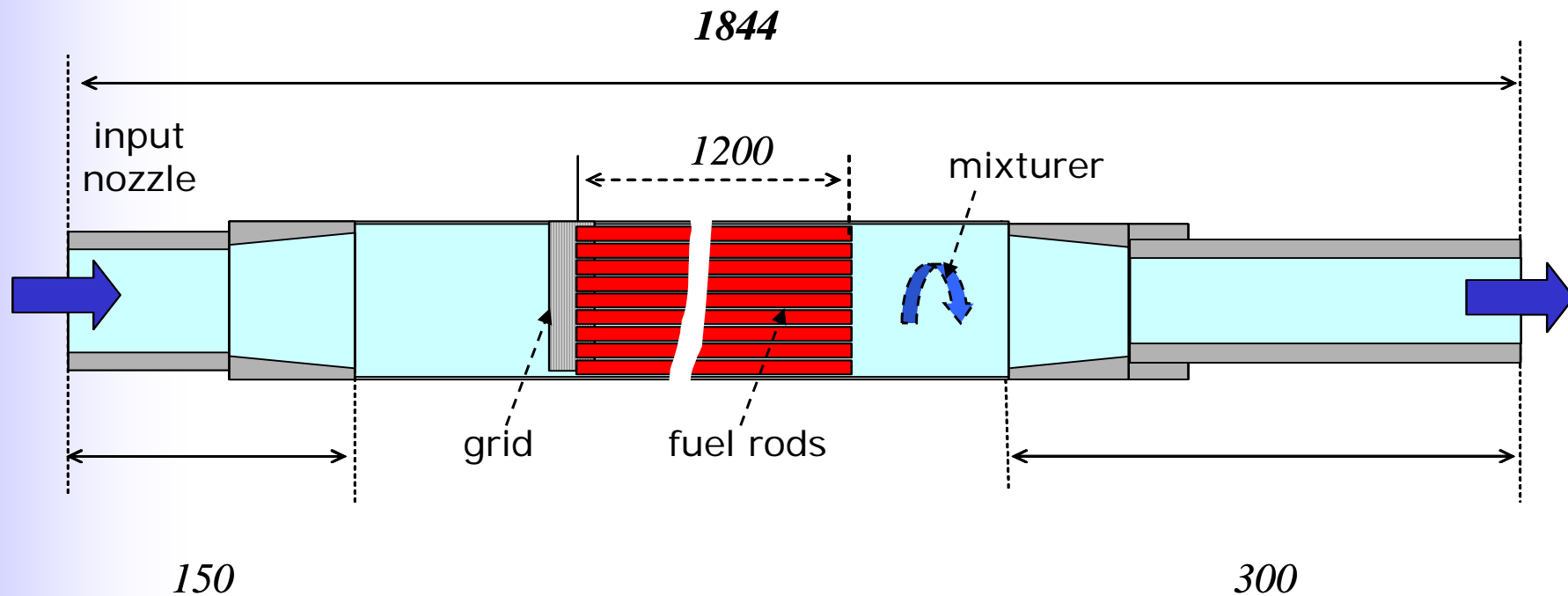

A typical design of LMFR sub-assembly has been adapted to the MYRRHA specific conditions.

...however the estimates have been performed only at start conditions.

5. Pre-design of a fuel assembly (8)



Main geometrical parameters (*in mm*) of the hexagonal sub-assemblies of some LMFR and of ADS MYRRHA.

	SPX	Phenix	SNR-300	BN-600	EFR(II)	MYRRHA
Number of pins	271	217	166+3	127	331	91
Pin diameter	8.50	6.55	6.00	6.9	8.2	6.55
SA Width	173	124	110.25	96	183	85.5
Total length	5400	4300	3700	3500	5300	1844
Fuel pin length	2700	1793	2475	2400	3600	1200
SA Pitch	179	127	115	98	188	87

6. Preliminary estimations of fuel operation parameters (1)



Input from neutronic modelling: Power and flux in the hottest rod

Neutron flux (near the hottest rod): total $E_n > 0.75 \text{ MeV}$ $E_n > 1 \text{ MeV}$	$10^{15} \text{ n/cm}^2 \text{ s}$	4.0 1.0 0.8
Core thermal power	MW	51.8
Peak power density (fuel)	kW/cm^3	1.54
Average power density (fuel)	kW/cm^3	0.937
Radial power form-factor	(max/aver rod)	1.29
Peak liner power (hottest rod)	W/cm	352
Average liner power (hottest rod)	W/cm	272
Axial power form-factor (hottest rod)	(max/aver)	1.30

6. Preliminary estimations of fuel operation parameters (2)



Input from neutronic modelling: Power distribution in the hottest assembly and in the hottest rod

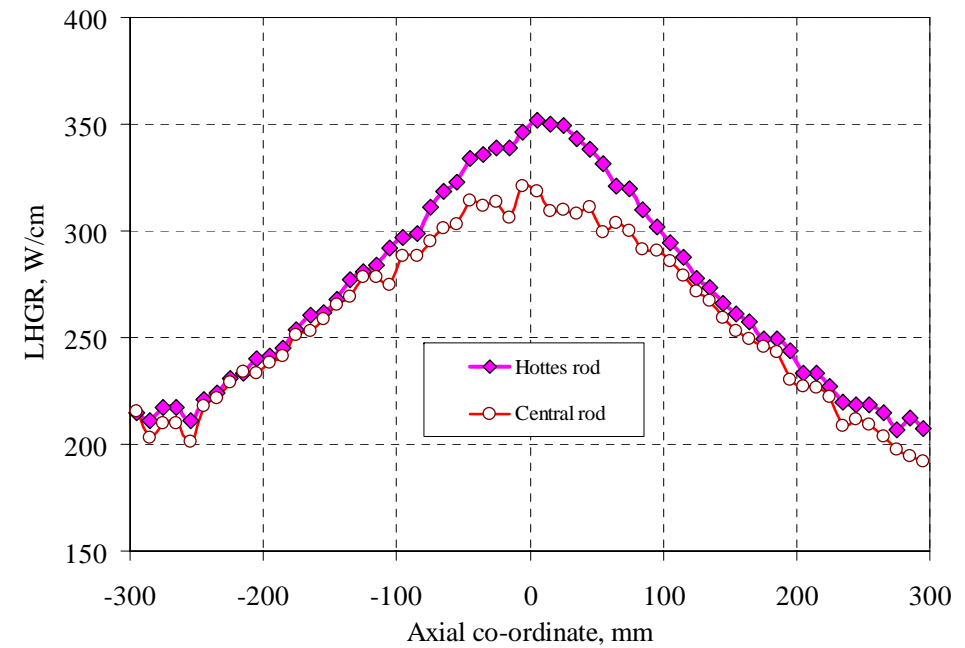
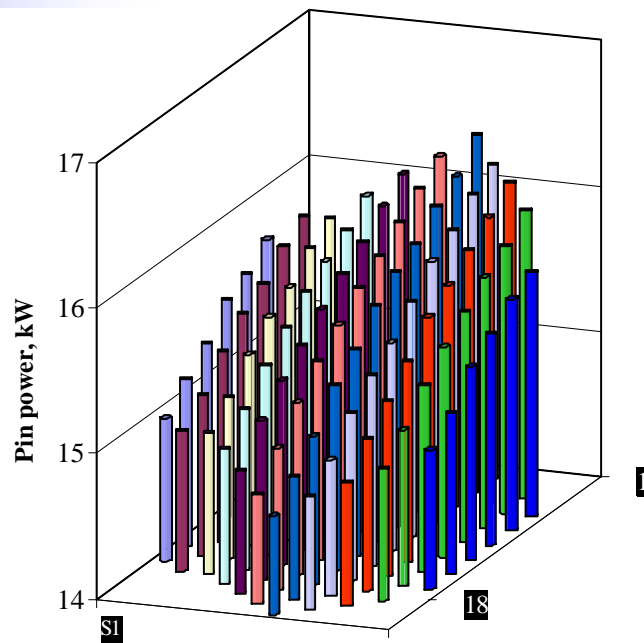

6. Preliminary estimations of fuel operation parameters (3)



Initial axial temperature distribution in the hottest rod

$T_{\text{melt}} = 2685 \text{ }^\circ\text{C}$

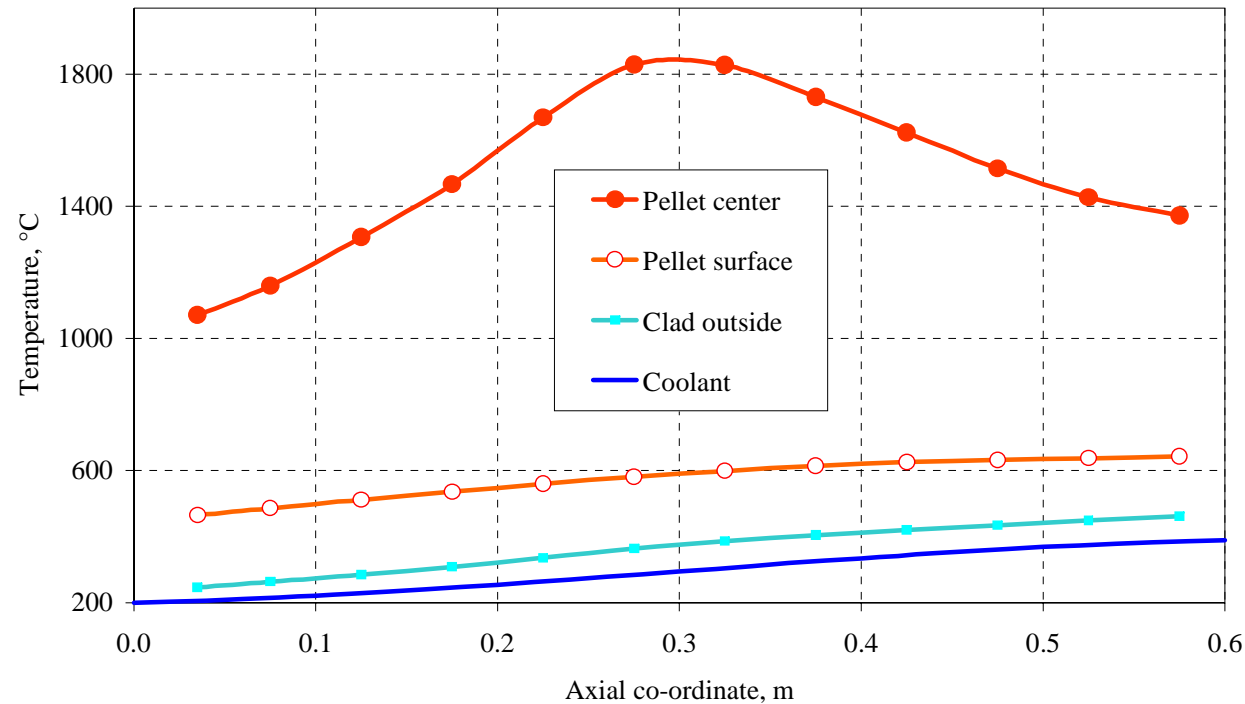

6. Preliminary estimations of fuel operation parameters (4)



Initial radial temperature distribution in the hottest rod

$T_{\text{melt}} = 2685 \text{ } ^\circ\text{C}$

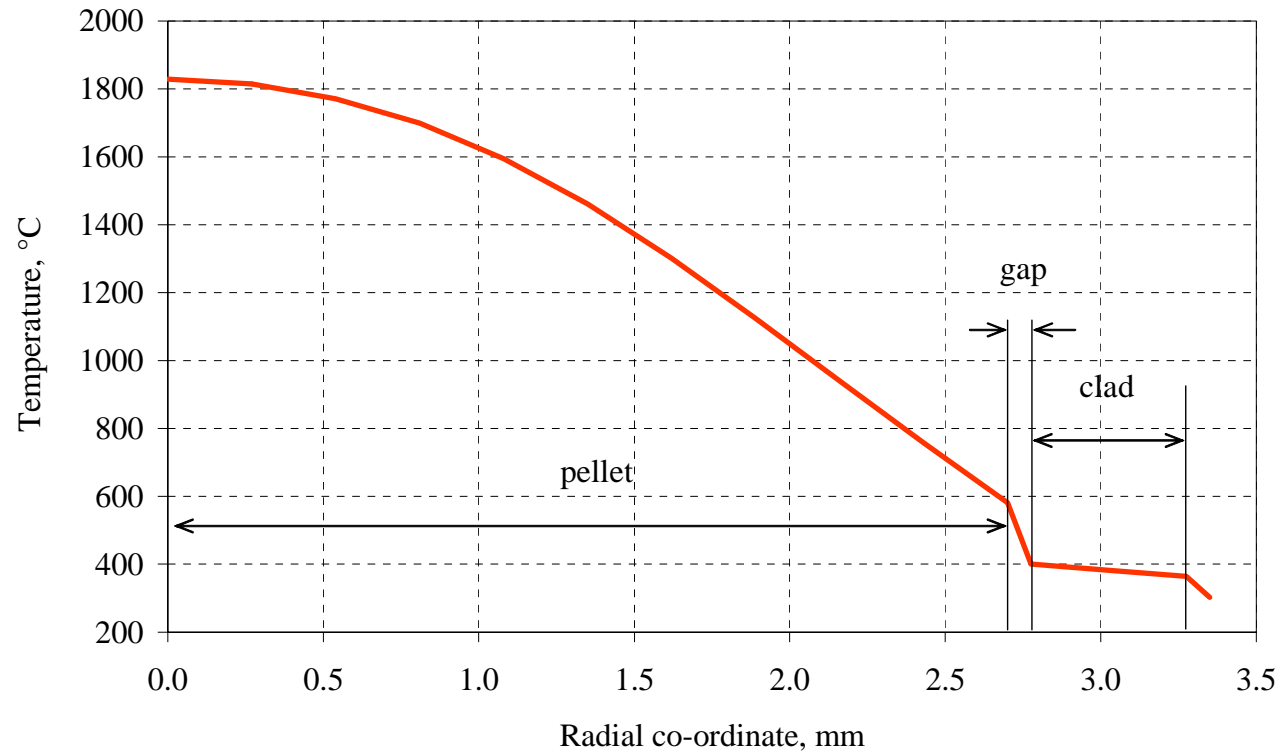

6. Preliminary estimations of fuel operation parameters (5)



"Pellet-clad" gap at start within the hottest rod

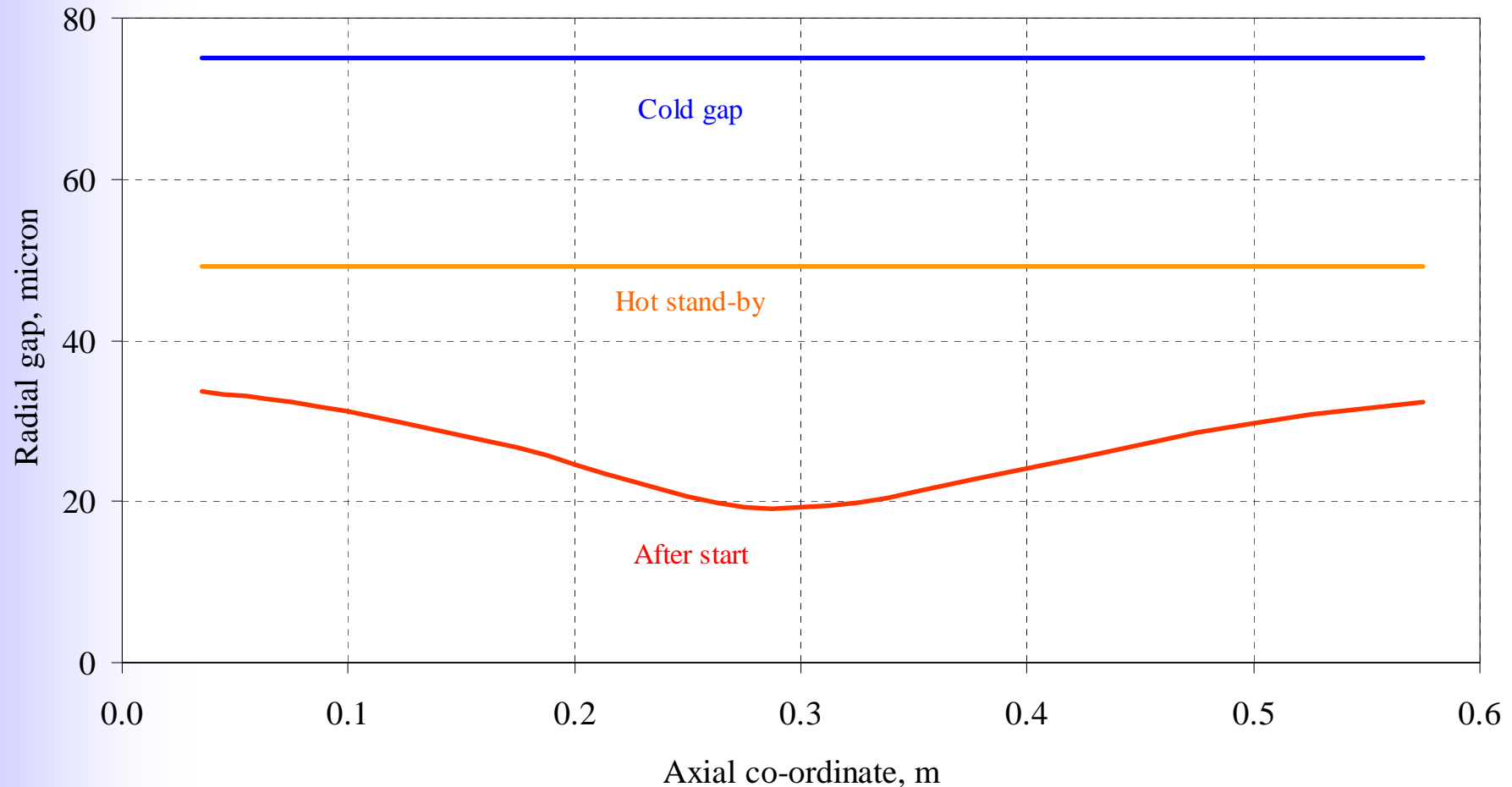

6. Preliminary estimations of fuel operation parameters (6)



Two scenario's for the proton beam operation in a cycle

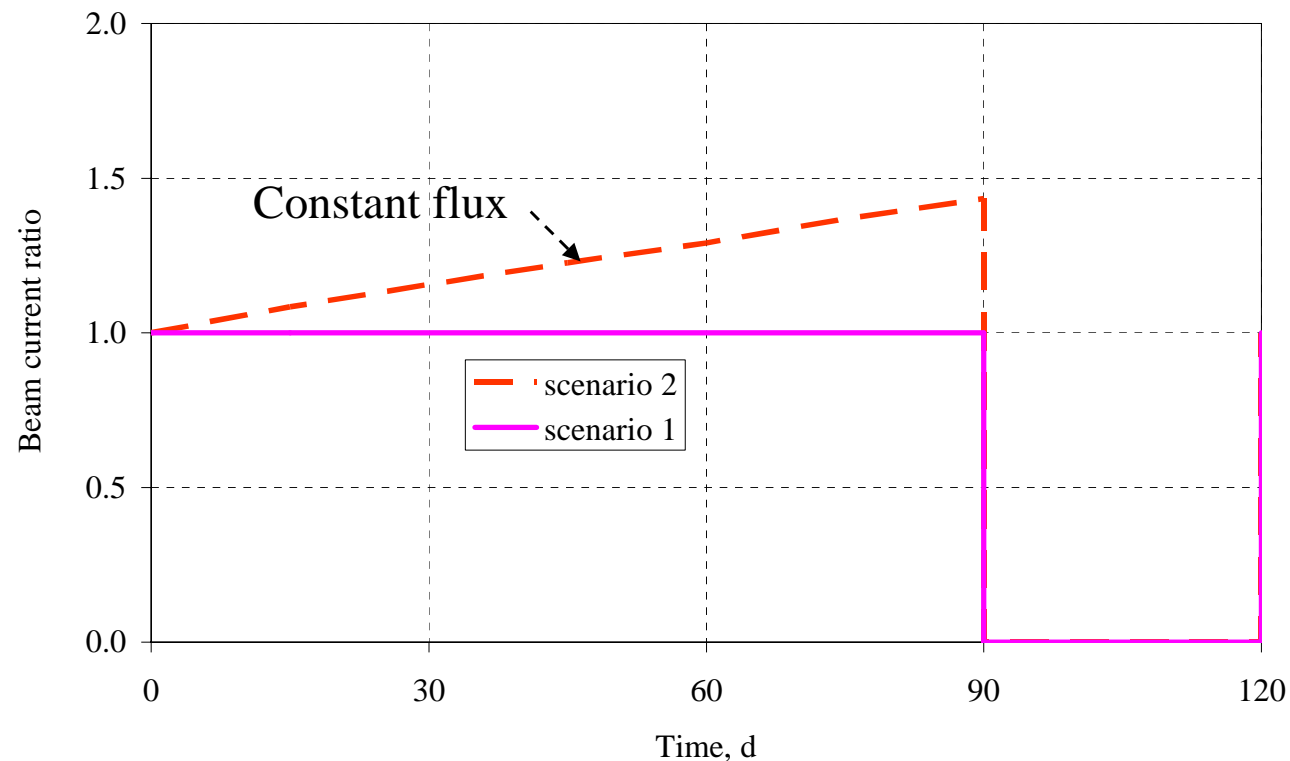

6. Preliminary estimations of fuel operation parameters (7)



Power history and peak burnup evolution in the hottest rod (constant flux regime)

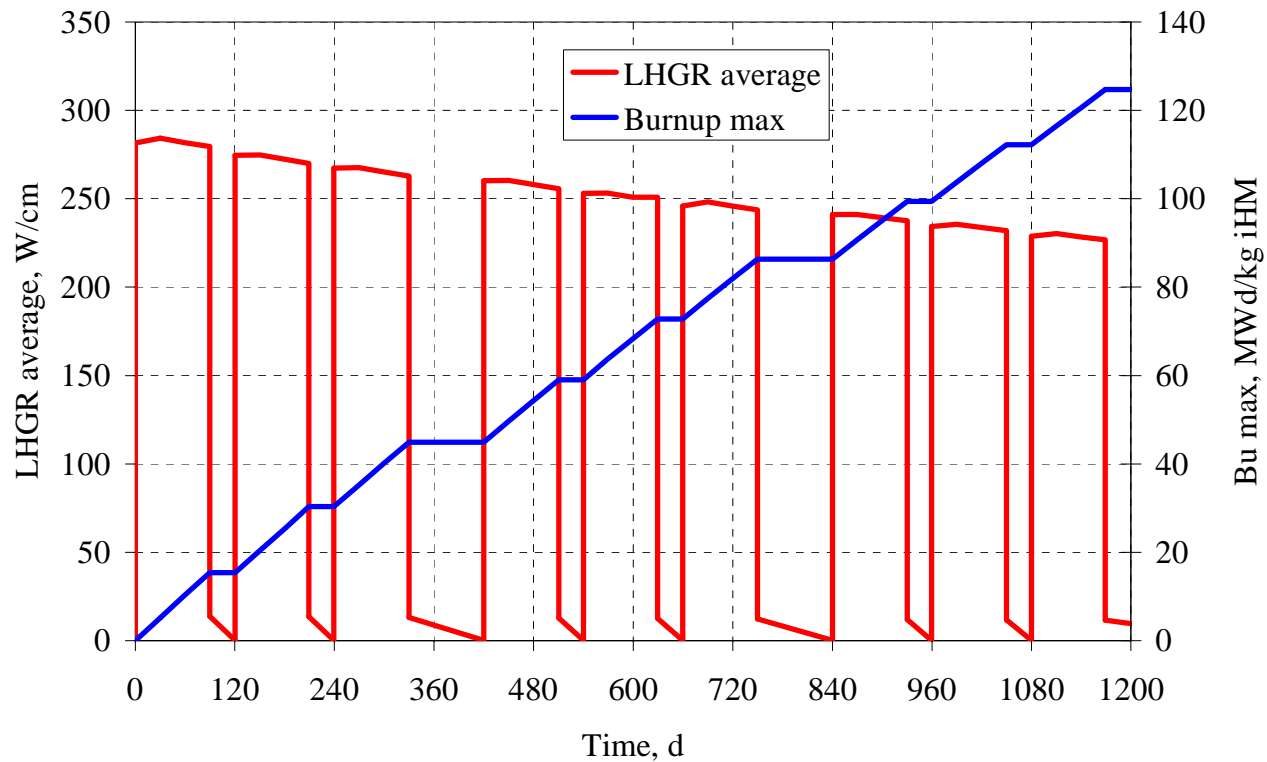

6. Preliminary estimations of fuel operation parameters (8)



Peak temperature evolution in the hottest rod
(modelling with MACROS)

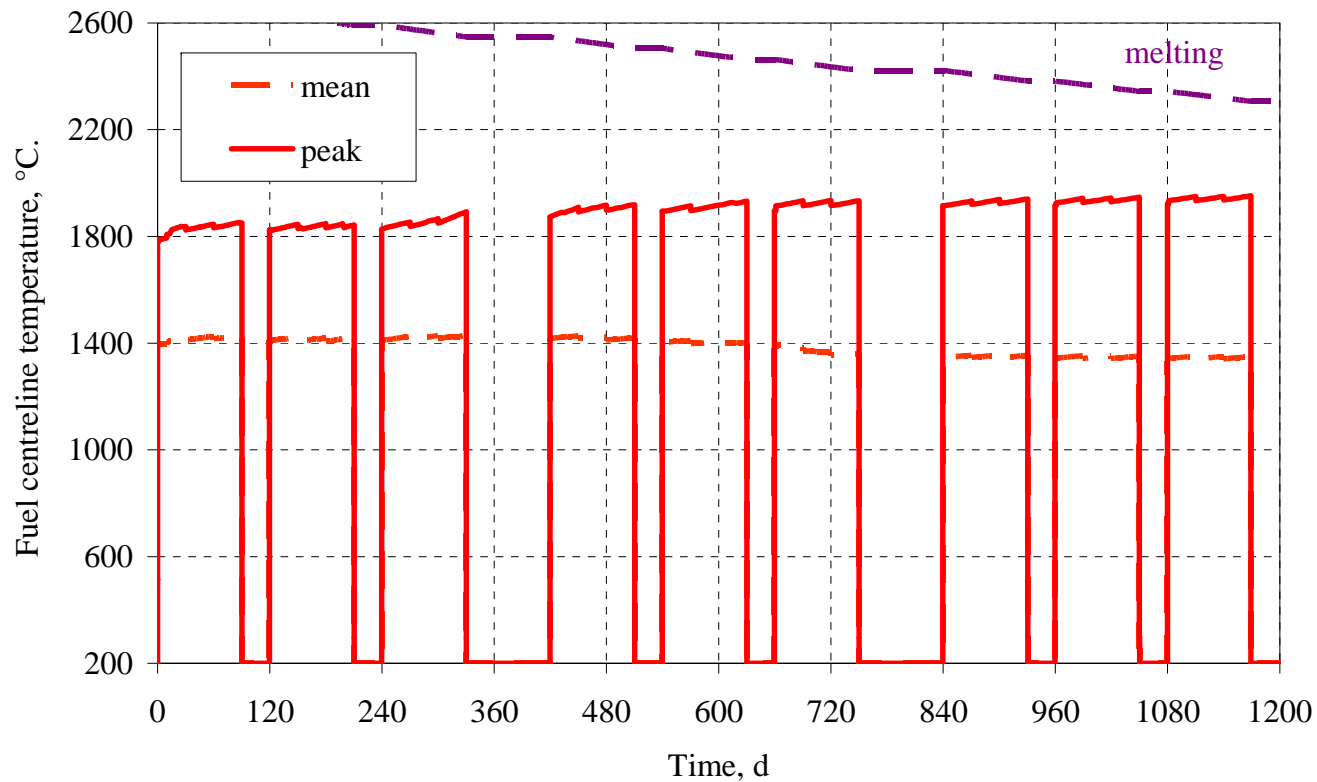

6. Preliminary estimations of fuel operation parameters (8a)



Peak temperature evolution in the hottest rod
(modelling with FEMAXI - conservative case)

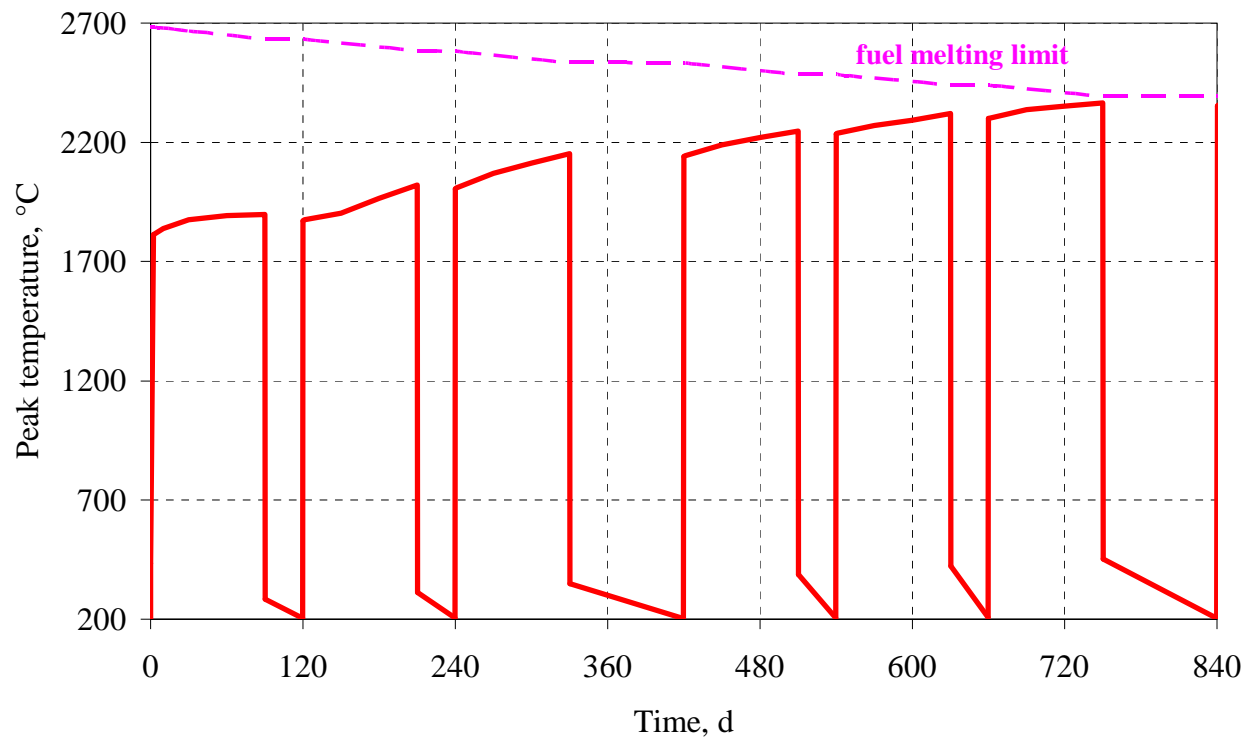

6. Preliminary estimations of fuel operation parameters (9)



Evolution of the mid-plane pellet-clad gap in the hottest rod
(modelling with MACROS)

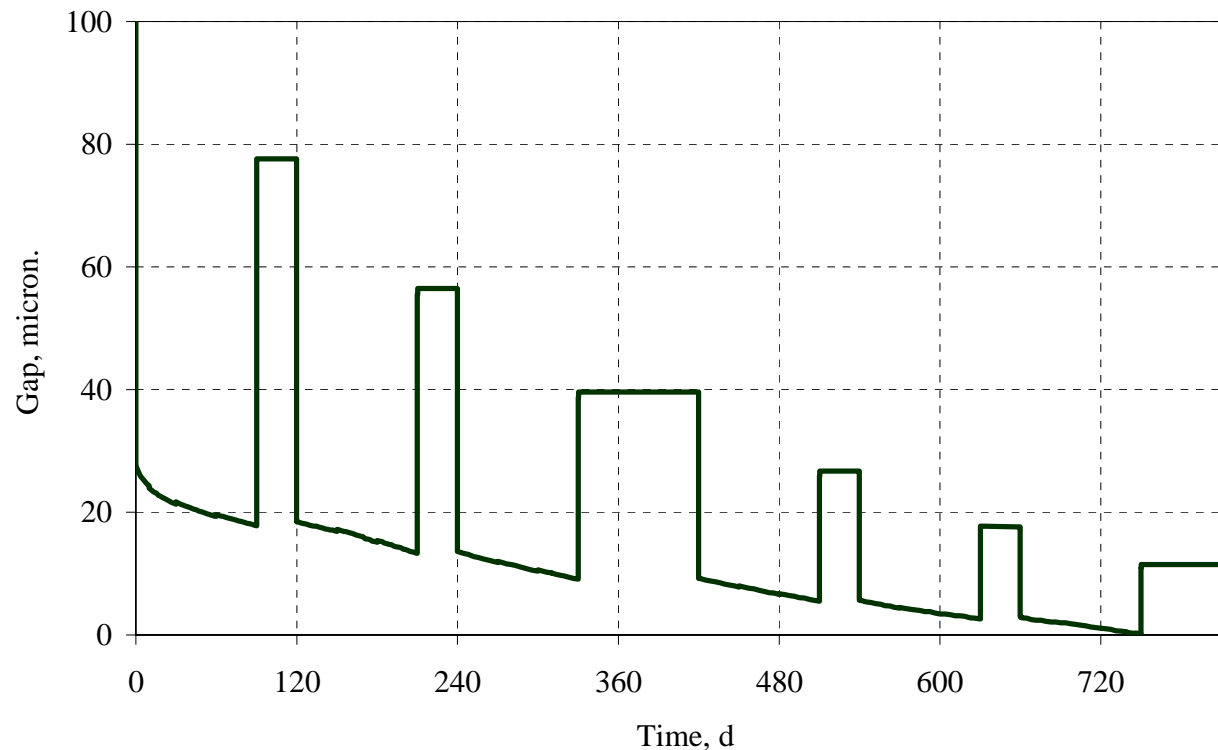

6. Preliminary estimations of fuel operation parameters (9a)



Evolution of the mid-plane pellet-clad gap in the hottest rod
 (modelling with FEMAXI - conservative case)

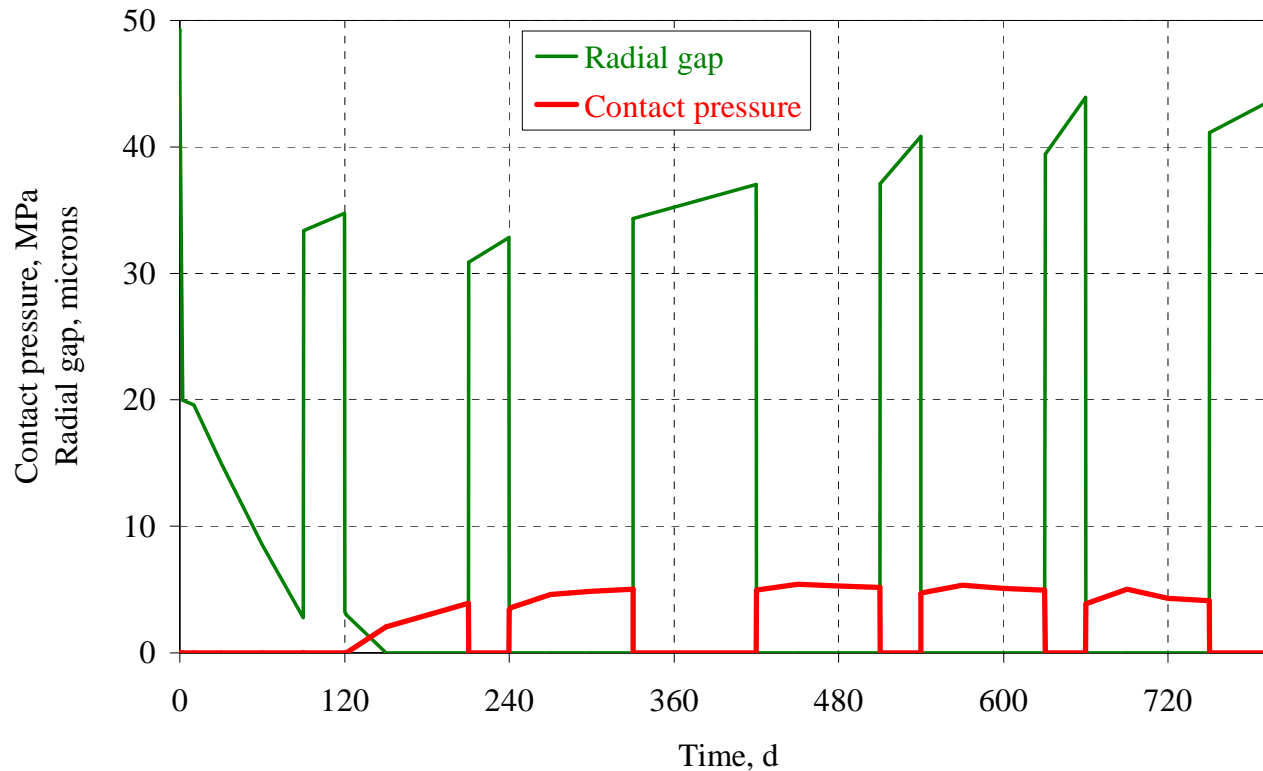

6. Preliminary estimations of fuel operation parameters (10)



FGR and pressure build-up in the hottest rod (modelling with MACROS)

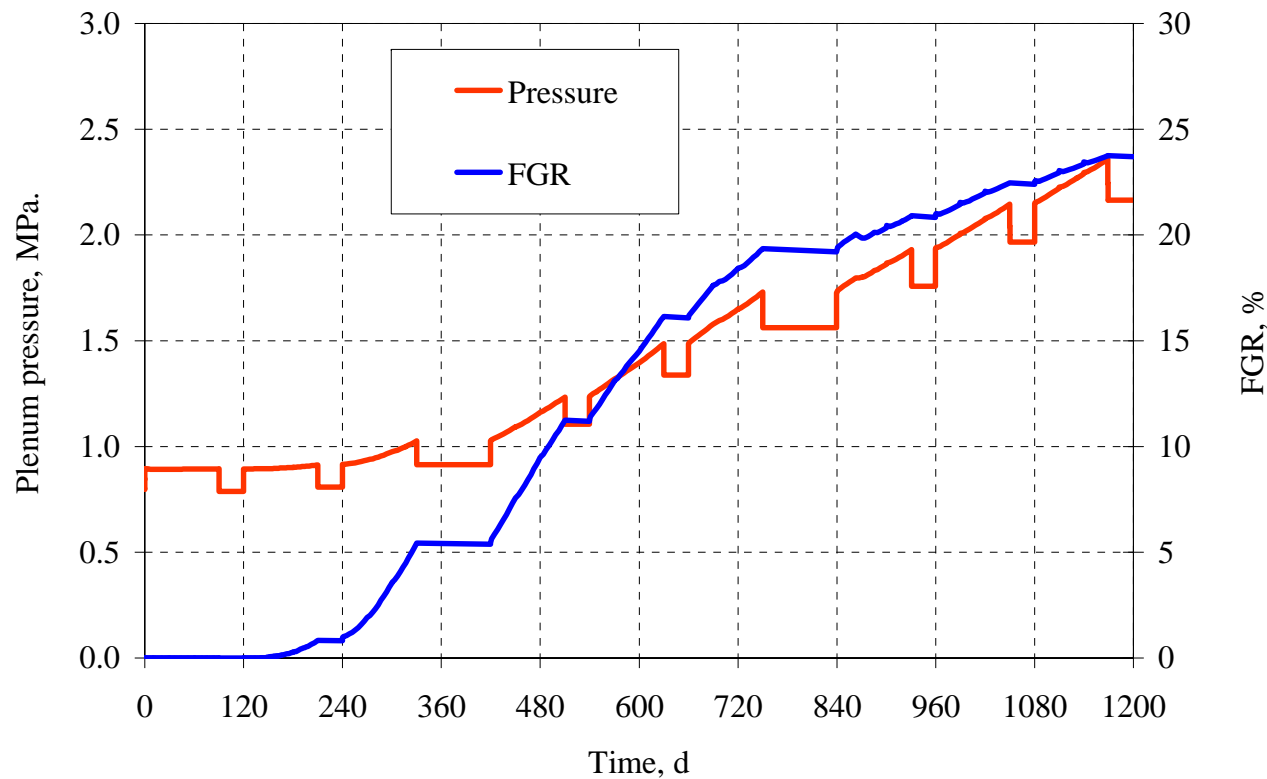

6. Preliminary estimations of fuel operation parameters (10a)



FGR and pressure build-up in the hottest rod (modelling with FEMAXI - conservative case)

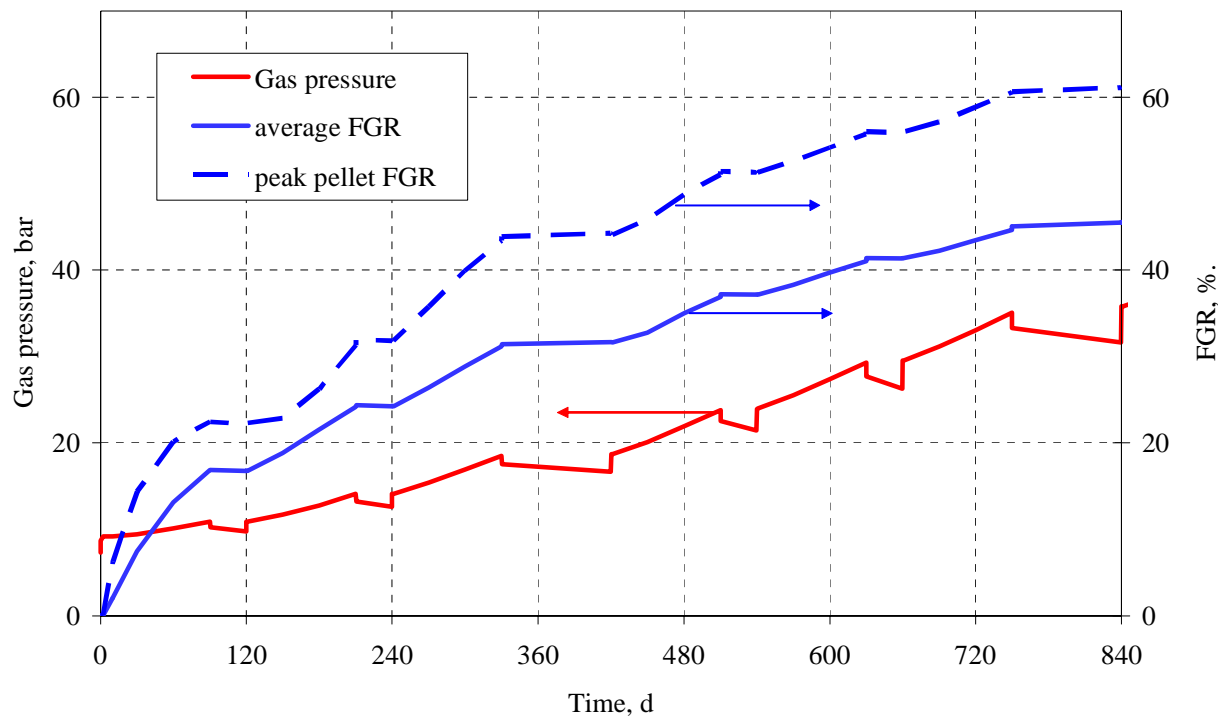

6. Preliminary estimations of fuel operation parameters (11)



Clad oxidation and temperature rise in the hottest rod

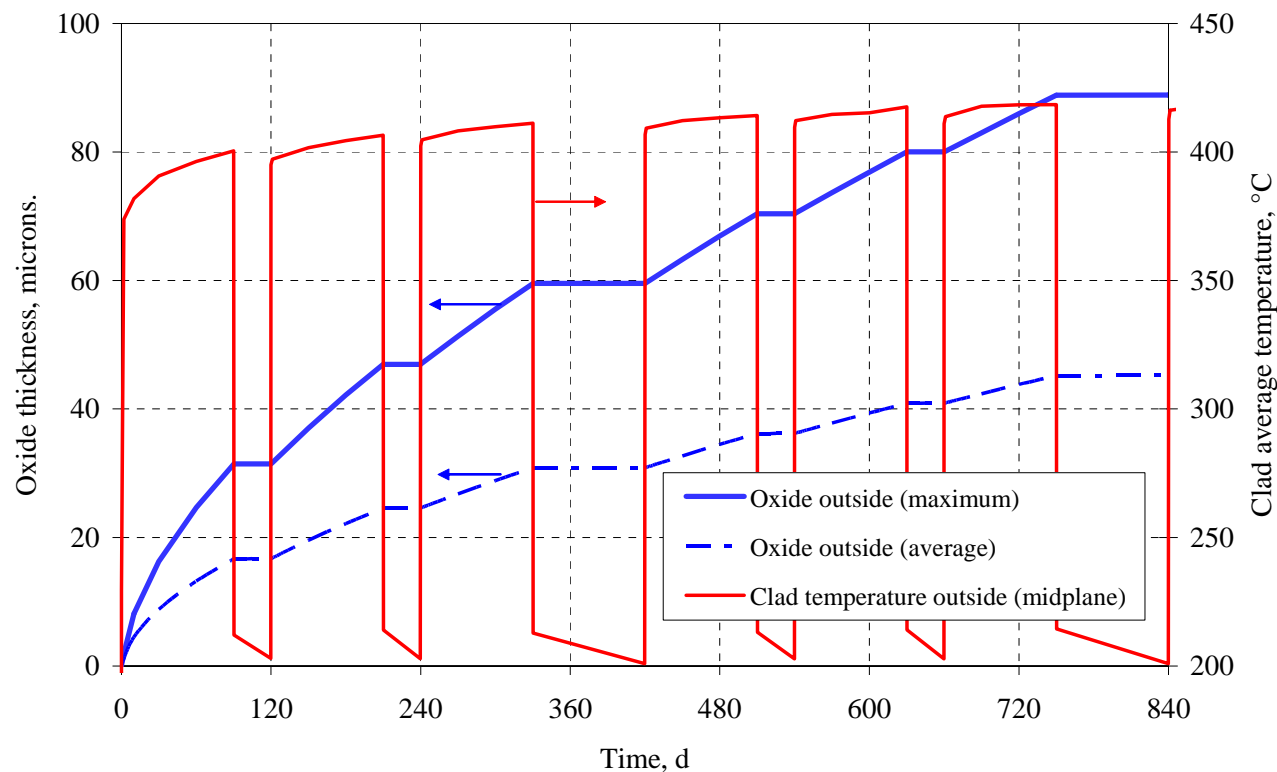

A better protection of the T91 cladding is needed or a lower temperature after 2-3 cycles of operation

6. Preliminary estimations of fuel operation parameters (12)



Pressure drop in assembly ($\langle T \rangle = 300 \text{ }^\circ\text{C}$, $G = 55.5 \text{ kg s}^{-1}$)

$$\Delta p_{assembly} = \sum_i \Delta p_i = \frac{G^2}{2 \cdot \rho} \cdot \sum_i \frac{\xi_i^{(friction)} + \xi_i^{(contr/exp an)}}{S_{i flow}^2}$$

No.	Element	Δp	
		bar	%
1	Inlet tube, nozzle, hex-duct	0.05	3.1
2	Fuel rod bundle (free part)	1.37	85.6
3	Upper grid	0.12	7.5
4	Upper hex-duct, matching cone, outlet tube	0.06	3.8
	TOTAL	1.6	

A more detailed thermal hydraulic modelling of assembly was performed with RELAP5 by SH, ... but the results at the normal operation have not yet been included in Draft-2

6. Preliminary estimations of fuel operation parameters (13)



Thermomechanical modelling of assembly (with STRAW by BELGONUCLEAIRE, but old variant from Draft-1)

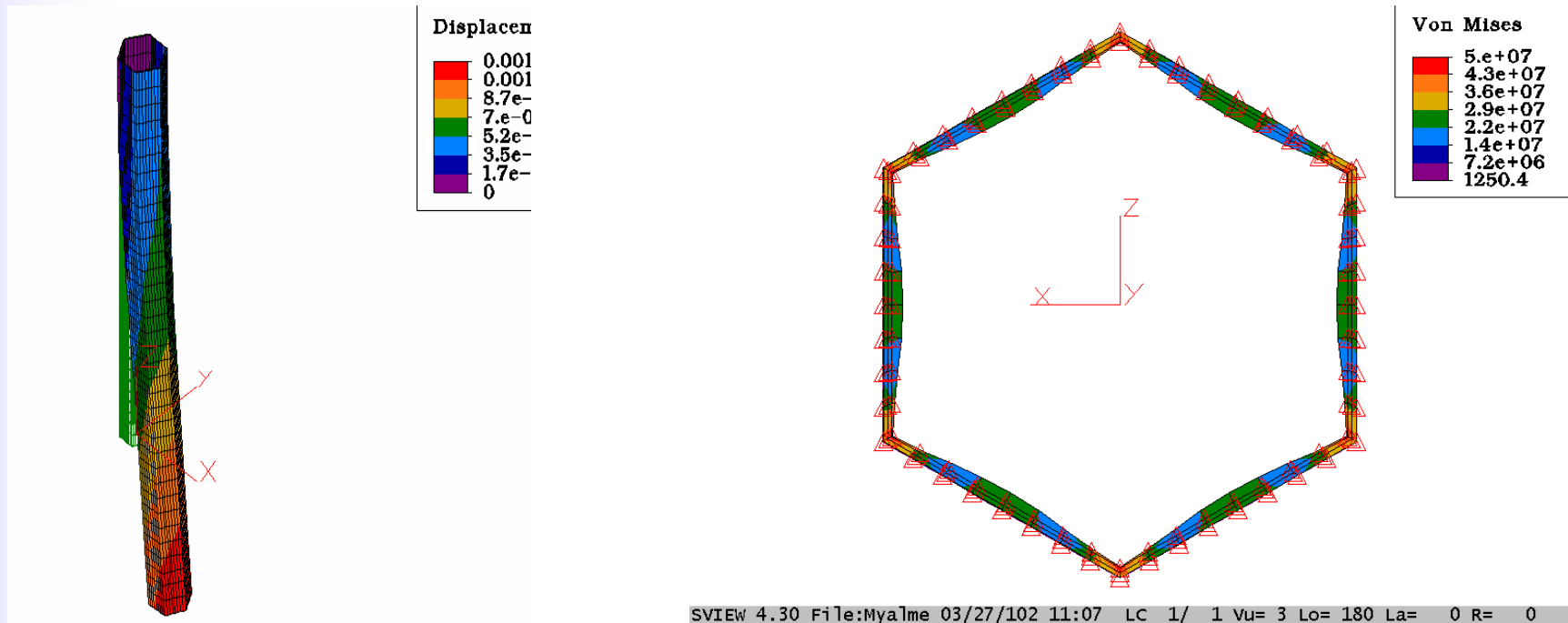

*Thermomechanical modelling of assembly has still to be performed .
 ... but with which code?*

7. Items still under consideration



- To fix the fuel Pu enrichment and the Pu isotopic vector.
- To establish a highly enriched MOX (30% Pu) properties database up to burn-up of 100 MWd/kg iHM.
- To establish the irradiated cladding properties database (T91 and others).
- To define realistic core management scenarios (k_{eff} swing compensation with meeting the requested performance).
- To perform thermomechanical modelling of fuel assembly.
- To optimise the current designs of fuel rod and fuel assembly.

8. Conclusions (I)



- Preliminary design of the MYRRHA fuel rod, fuel assembly and core has been updated to meet 50 MW(th) power.
- Modelling of the thermomechanical behaviour of the fuel rod under conservative (constant flux) irradiation conditions shows that the initial safety margins are sufficient for about three (two) years of the normal operation up to the aimed maximum burnup of ~100 MWd/kg iHM.
- The clad damage limit of 100 dpa are estimated to be within the achievable range taking into account the clad operating temperature range of 250-480 °C and the moderate He production rate (maximum 8 appm He/dpa).

8. Conclusions (II)



- The designed hexagonal fuel assemblies with medium pitch ratio of 1.3 can provide the adequate heat removal at normal operation with the maximum LBE local velocity of 2 m s^{-1} (and at protected DBC transients ?).
- The following progress in the optimisation of the designs of the fuel pin and the fuel assembly will be made after solving urgent problems existing in the fuel and cladding database properties and redefining a realistic core management scenarios.
- A validation and qualification programme for fuel is highly recommended to start ASAP, taking into account that at least 2-3 (up to 5) years are needed to fulfil this kind of irradiation programme.

Acknowledgements



This presentation was prepared
with the contributions of

LEMEHOV Sergei,
AI MAZOUZI Abderrahim,
MALAMBU Edouard,
HAECK Wim

ANNEX

What we had in DRAFT-1



- Only two pages on the fuel pin and assembly design (pp. 20-22, three figures included) were presented in the Draft-1 Document.
- Three different fuel designs were analysed: SPX, BN-600 and SNR-300.
- The existing SPX fuel design (but with HT-9, T91 or AISI 316L cladding) was used as reference in order to keep the shortest pre-design and expected deployment schedules.
- A high flux of the fast neutrons: $\sim 10^{15}$ n/cm²s in the hottest experimental channels at the initial $k_{eff} \sim 0.95$. A small core thermal power - few tens of MW
- Fuel performance calculations only at start.

Options:

1. What actinides ? → enriched
U, **Pu-U**, Pu-Th, U-Th.
2. Enrichment level ?
→ *how to deal with "20 % U-235 equivalent limit"?*
3. What chemical form ?
→ metal, **oxide**, carbide, nitride.
4. Physical state ? → solid
solution, **mixture**, CERMET, ...

$(\text{Pu}, \text{U})\text{O}_2$ MOX with 30 wt.% RG Pu in HM has been chosen in MYRRHA, however, it would be useful to revisit other options.

Cladding choice

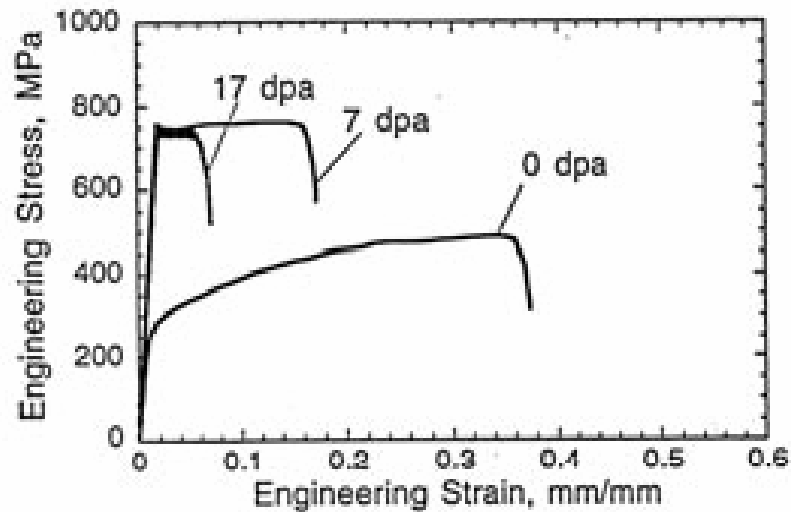
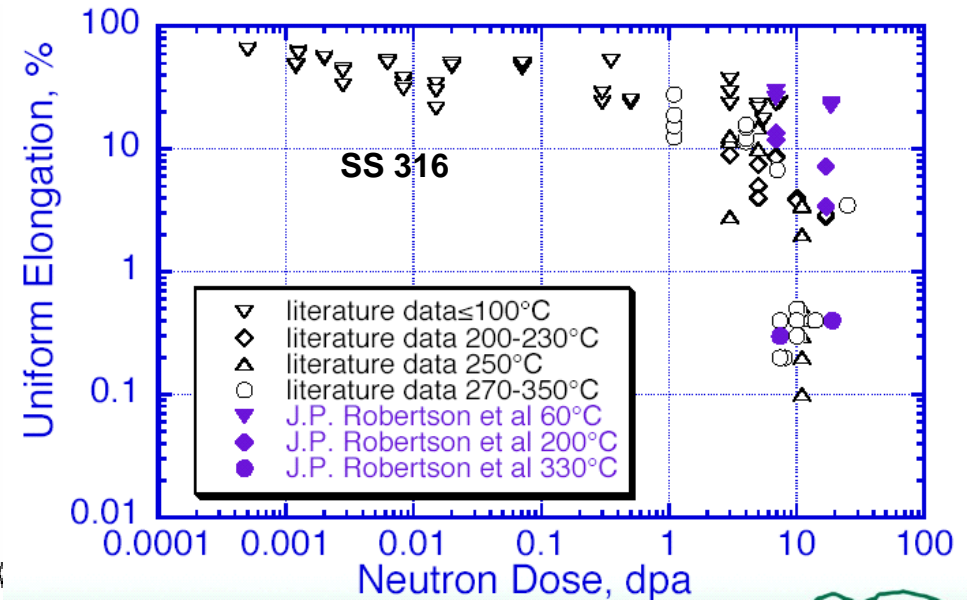

Figure 3-44. Effect of irradiation on the stress-strain curve of 316 SS at 473 K



Radial thermal resistivity of fuel rod

$$\mathcal{R}_{\text{pellet}} = \frac{1}{4 \cdot \pi \cdot \langle \lambda_{\text{pellet}} \rangle}$$

$$\langle \lambda_{\text{pellet}} \rangle \equiv \frac{1}{\Delta T_{\text{fuel}}} \cdot \int_{T_{\text{fuel surface}}}^{T_{\text{fuel centre}}} \lambda_{\text{pellet}}(T) \cdot dT$$

$$\mathcal{R}_{\text{cool}} = \frac{1}{\pi \cdot D_{\text{clad}} \cdot h_{\text{heat}}}$$

$$h_{\text{heat}} = 0.58 \cdot (1.1 \cdot x_{\text{pitch}}^2 - 1)^{0.55} \cdot \left(\frac{v_{\text{cool}} \cdot D_{\text{clad}}}{a_{p \text{ cool}}} \right)^{0.45} \cdot \frac{\lambda_{\text{cool}}}{D_{\text{clad}}}$$

$$\mathcal{R}_{\text{clad}} \approx \frac{\delta_{\text{clad}}}{\pi \cdot \langle D_{\text{clad}} \rangle \cdot \langle \lambda_{\text{clad}} \rangle}$$

$$\mathcal{R}_{\text{gap}} \approx \frac{\delta_{\text{gap}}}{\pi \cdot \langle D_{\text{gap}} \rangle \cdot \langle \lambda_{\text{gap}} \rangle}$$

Radial thermal resistivity of the holed pellet

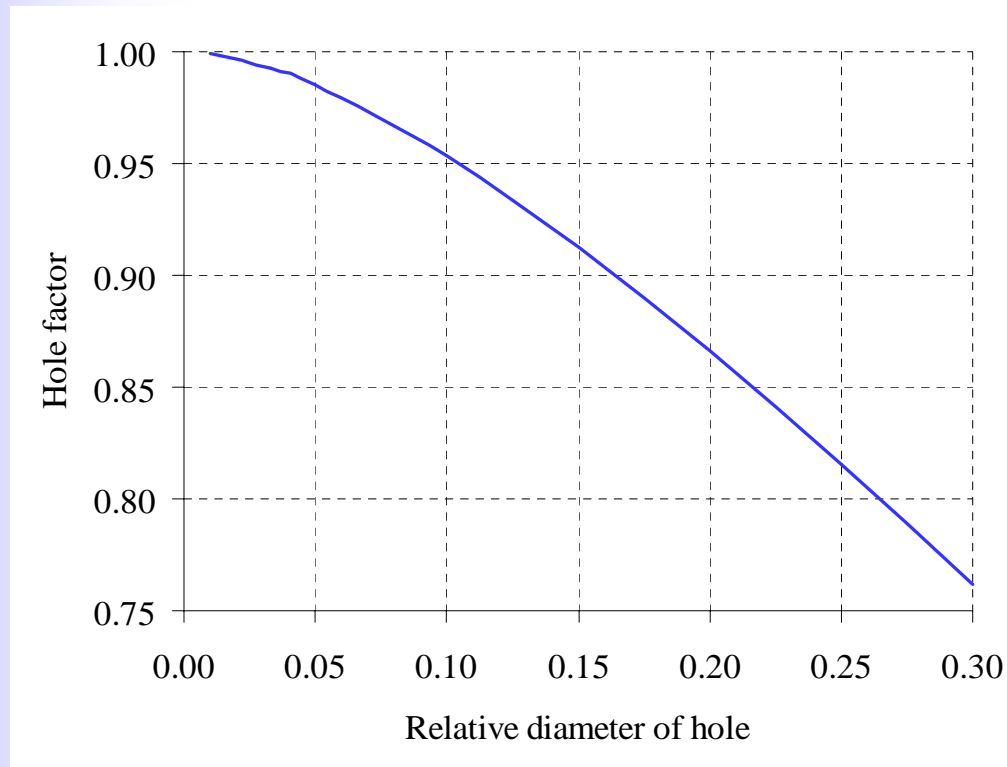

$$f_{pellet} = \frac{1}{4 \cdot \pi \cdot \langle \lambda_{pellet} \rangle} \cdot \left(1 + \frac{\left(\frac{d_{hole}}{D_{pellet}} \right)^2 \cdot \ln \left(\frac{d_{hole}}{D_{pellet}} \right)^2}{1 - \left(\frac{d_{hole}}{D_{pellet}} \right)^2} \right)$$

$$\langle \lambda_{pellet} \rangle \equiv \frac{1}{\Delta T_{fuel}} \cdot \int_{T_{fuel\ surface}}^{T_{fuel\ centre}} \lambda_{pellet}(T) \cdot dT$$

Determination of fuel pellet sizes



Radial thermal resistivity of the coolant boundary layer: $v = 2 \text{ m/s}$, $\langle T \rangle = 300 \text{ }^\circ\text{C}$

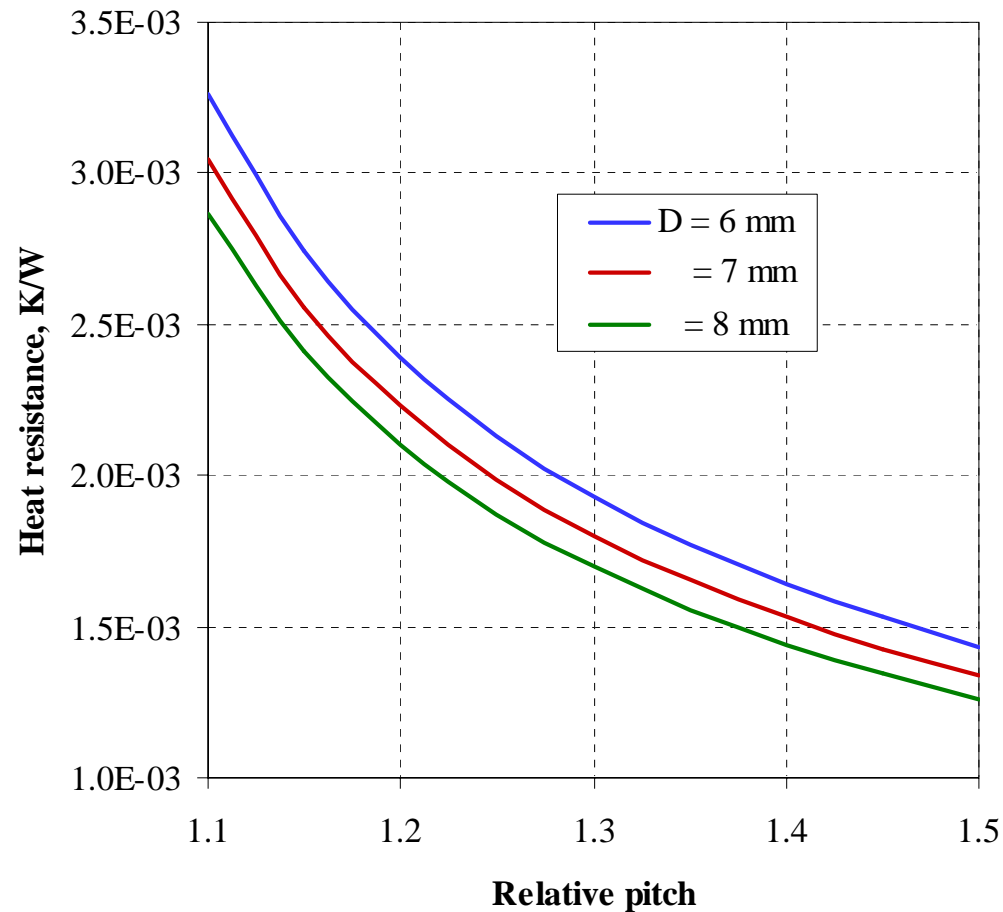

Radial thermal resistivity of 0.5 mm T91 cladding

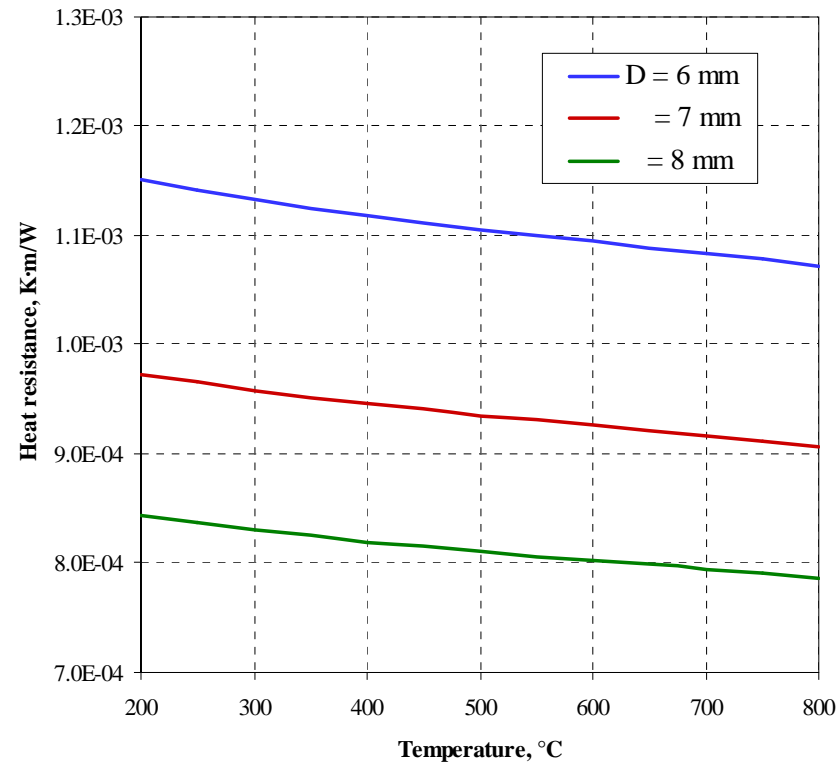

Radial thermal resistivity of 0.1 mm gap filled with He-gas at 0.5 MPa (STP)

