



**The Abdus Salam
International Centre for Theoretical Physics**



2065-11

**Advanced Training Course on FPGA Design and VHDL for Hardware
Simulation and Synthesis**

26 October - 20 November, 2009

Selected Topics on Logic Synthesis and FPGA Design

Andres Cicuttin
*ICTP Multidisciplinary Laboratory
ICTP
Trieste
Italy*



The Abdus Salam
International Centre for Theoretical Physics



United Nations
Educational, Scientific
and Cultural Organization



International Atomic
Energy Agency

Selected Topics on Logic Synthesis and FPGA Design

Andres Cicuttin
ICTP Multidisciplinary Laboratory

**Advanced Training Course on
FPGA Design and VHDL for
Hardware Simulation and Synthesis**

Trieste, Italy
November 2009

Part A. Logic Synthesis

- VHDL Coding Style for Synthesis
- Pipeline inference
- Resource sharing. The Area-Speed tradeoff
- Primitives and Macros
- Multiple driving. Buses and Multiplexers

Part B. FPGA Design

- Synchronous Design
- Unavoidable and Avoidable Asynchronous Designs
- Special Asynchronous Circuits
- Debugging Techniques
- Common Mistakes and Good Design Practices

Some References (used in this presentation)

- Books on VHDL and FPGA design:
 - **Design Recipes for FPGAs**,
Peter Wilson (Elsevier, 2007)
 - **RTL Hardware Design Using VHDL**,
Pong P. Chu (John Wiley & Sons, 2006)
 - **The Design Warrior's guide to FPGAs**,
Cleve "Max" Maxfield (Elsevier, 2004)
 - **Digital Signal Processing with Field Programmable Gate Arrays**,
U. Meyer-Baese (Springer, 2004)
 - **Real Chip Design and Verification**,
Ben Cohen, (VhdlCohen Publishing, 2002)
- Web sites:
 - www.opencores.org, <http://asics.ws>,
 - www.fpga4fun.com, www.us.design-reuse.com,
 - www.fpga-faq.org, <http://www.andraka.com/papers.htm>, ...
 - Websites of FPGA companies (Actel, Altera, Xilinx,...)

VHDL for Synthesis

- Behavioral vs. Structural
- Coding Style and Synthesis
- Primitives and Macros
- Multiple Driving
 - Buses and Multiplexers
 - Potential conflicts (standard logic)
- The Area-Speed tradeoff

Different expression arrangement
could determine different structures

```
result <= ((a+b)+(c+d))+((e+f)+(g+h)) ;
```

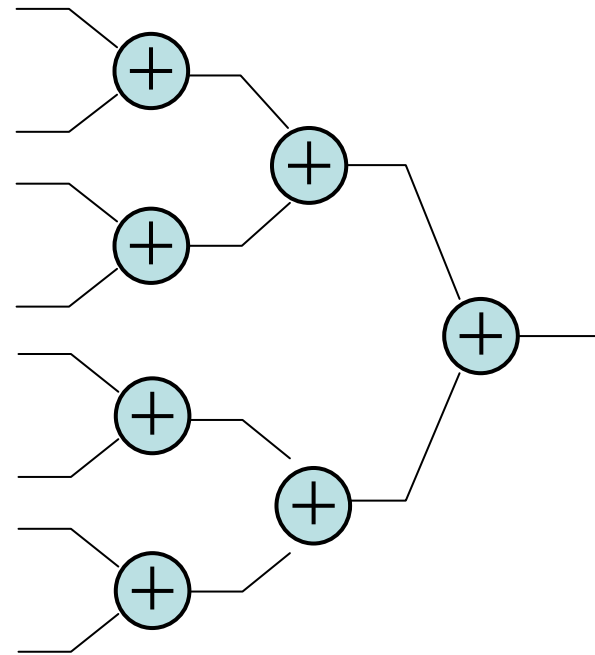

```
result <= (((((a+b)+c)+d)+e)+f) ;
```

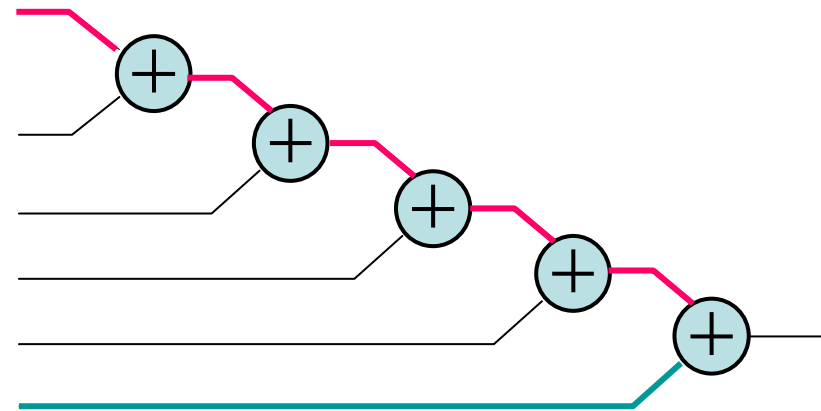

Parallel implementation of
 $ABCDEFGH \leq (a*b)+(c*d)+(e*f)+(g*h)$ after 10ns;

```
--Concurrent statements  
  
AB  <= A * B ;  
CD  <= C * D ;  
EF  <= E * F ;  
GH  <= G * H ;  
  
ABCD <= AB + CD ;  
EFGH <= EF + GH ;  
  
ABCDEFGH <= ABCD + EFGH ;
```

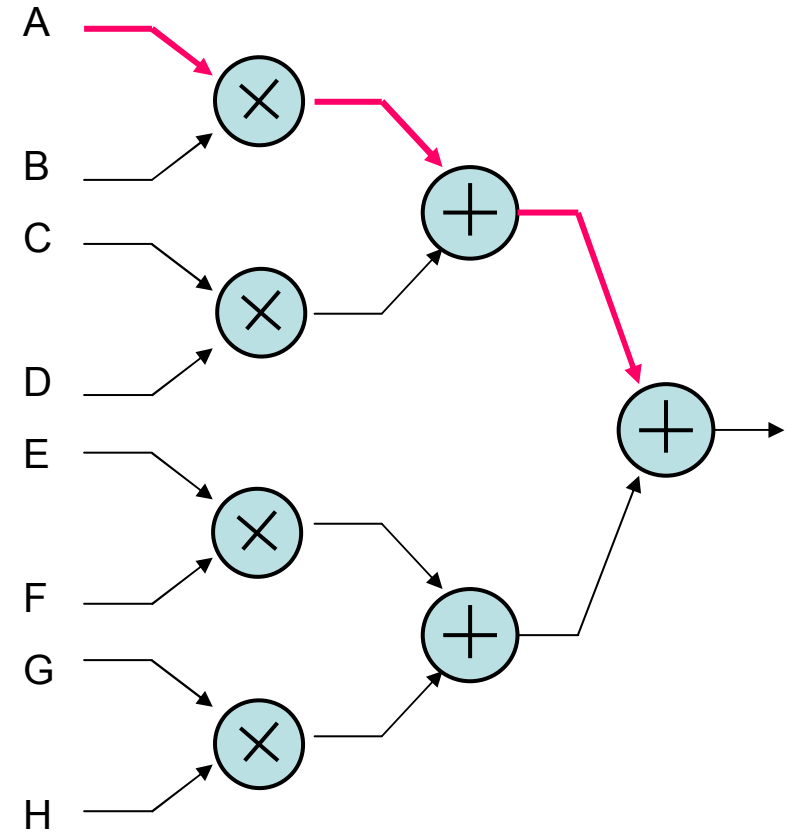

How to obtain more performance?

The Synchronous Pipeline Concept

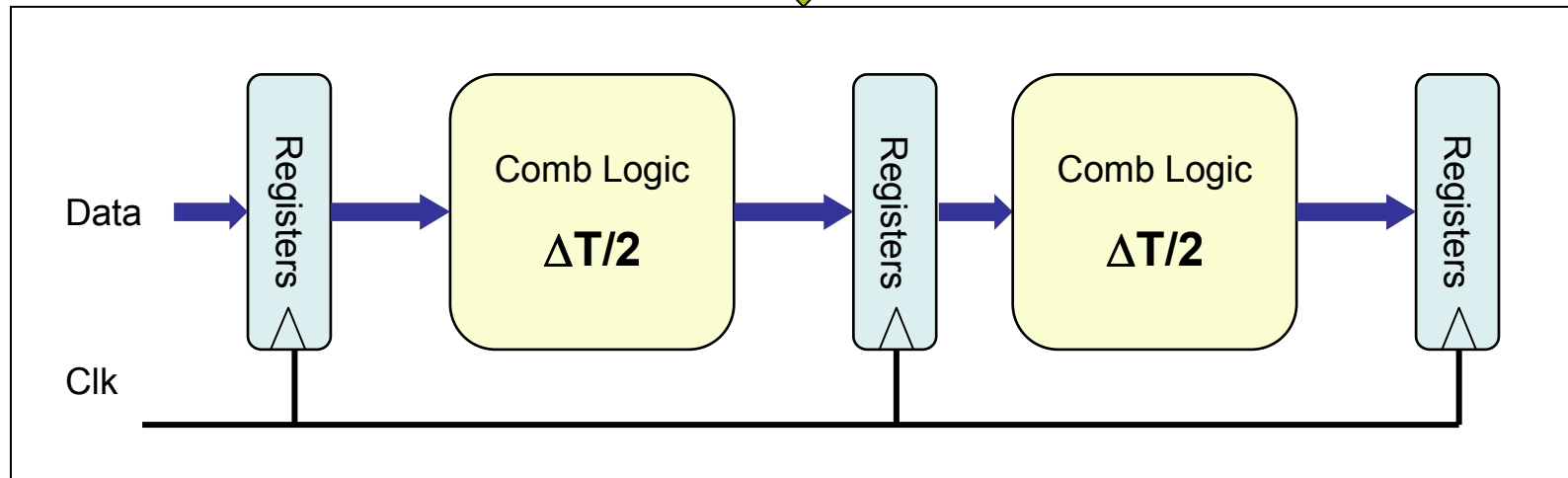
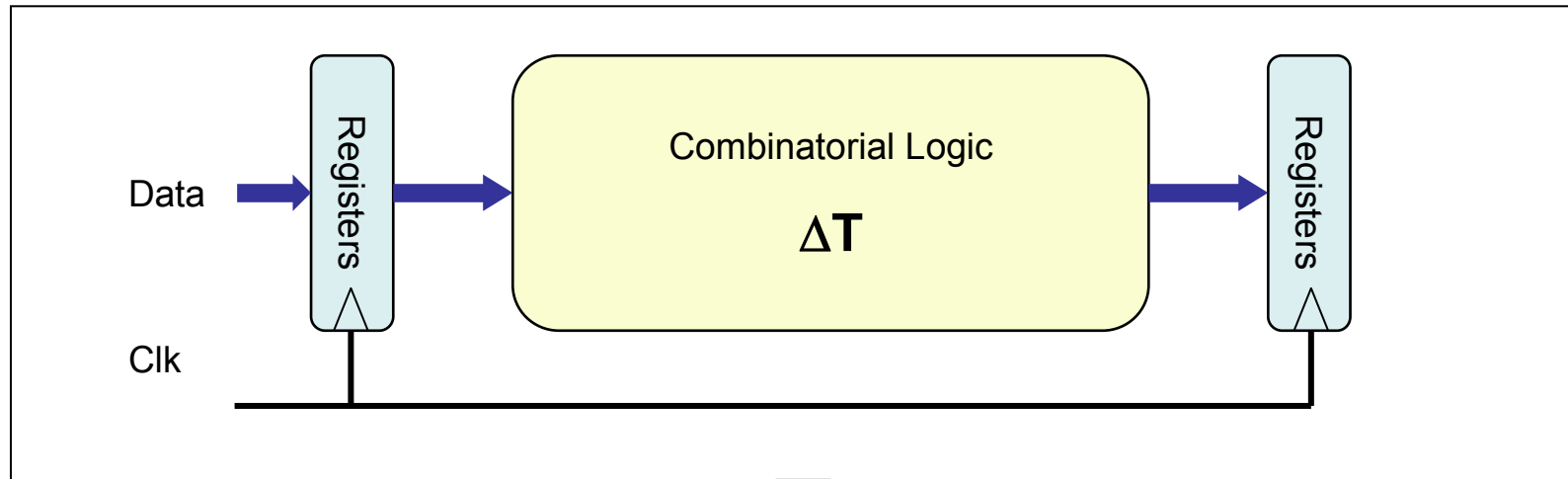

Pipeline implementation of $(a*b)+(c*d)+(e*f)+(g*h)$

```
process (<clock>)  
begin  
  if <clock>'event and <clock>='1'  
    then  
      AB <= A * B ;  
      CD <= C * D ;  
      EF <= E * F ;  
      GH <= G * H ;  
  
      ABCD <= AB + CD ;  
      EFGH <= EF + GH ;  
  
      ABCDEFGH <= ABCD + EFGH ;  
    end if;  
  end process;
```

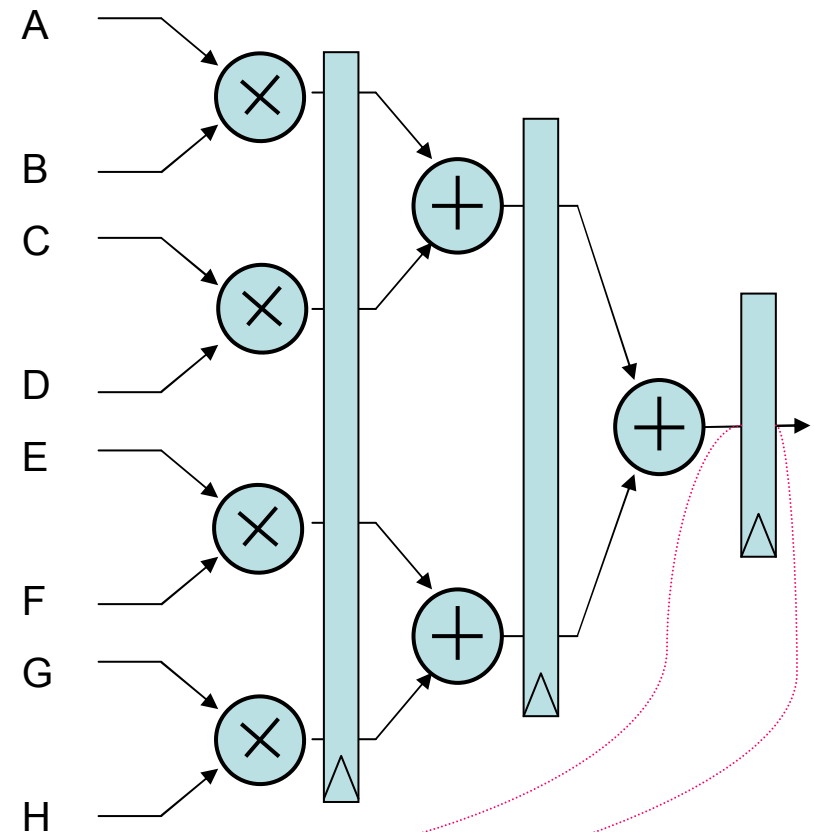

- 1) what about synchronizing the Input signals?
- 2) Can we use less resources for the same function?

Resource Sharing

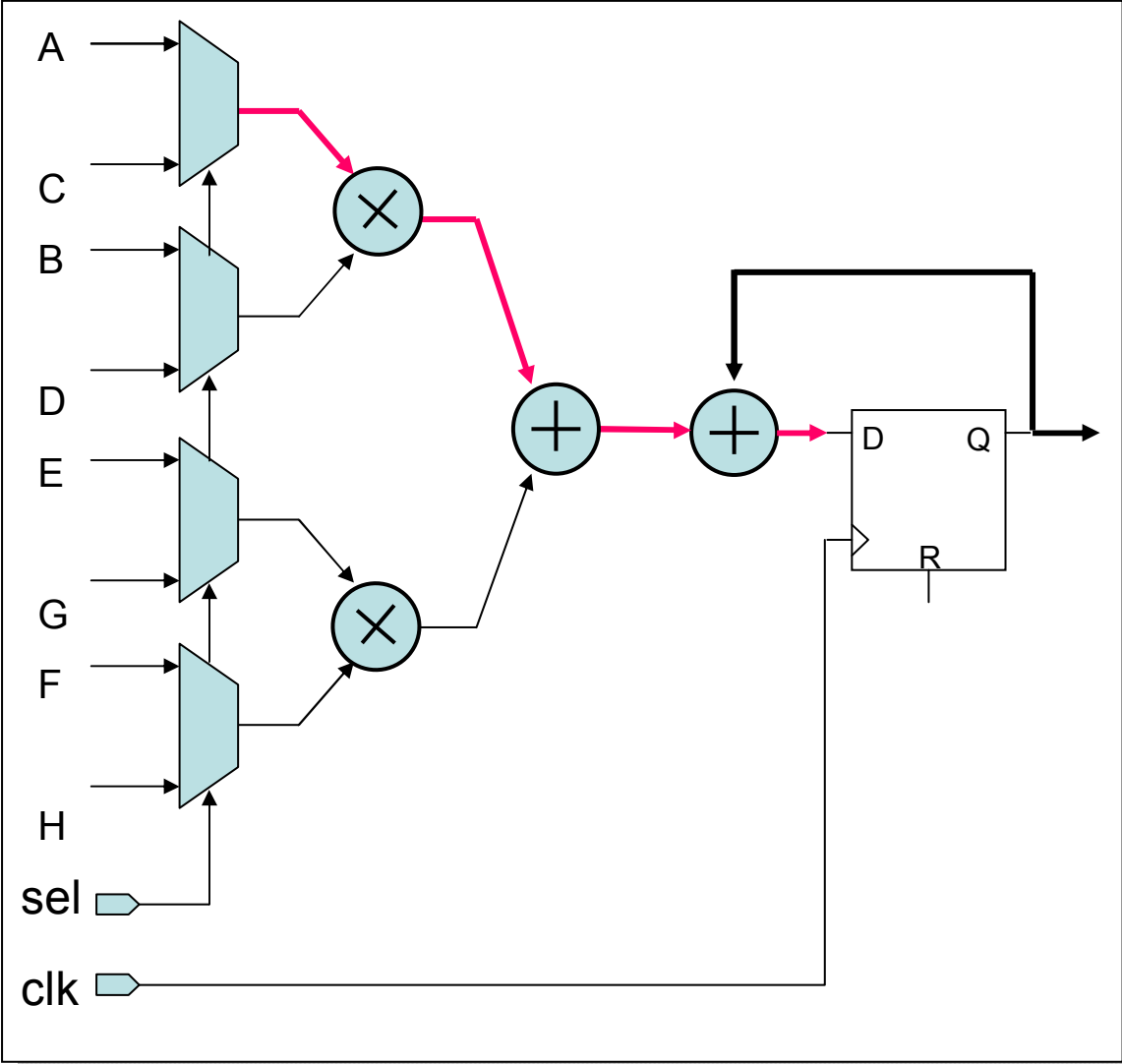
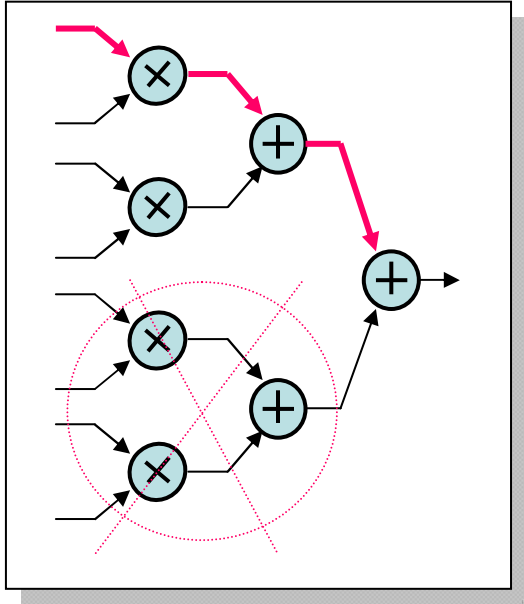

More Resource Sharing

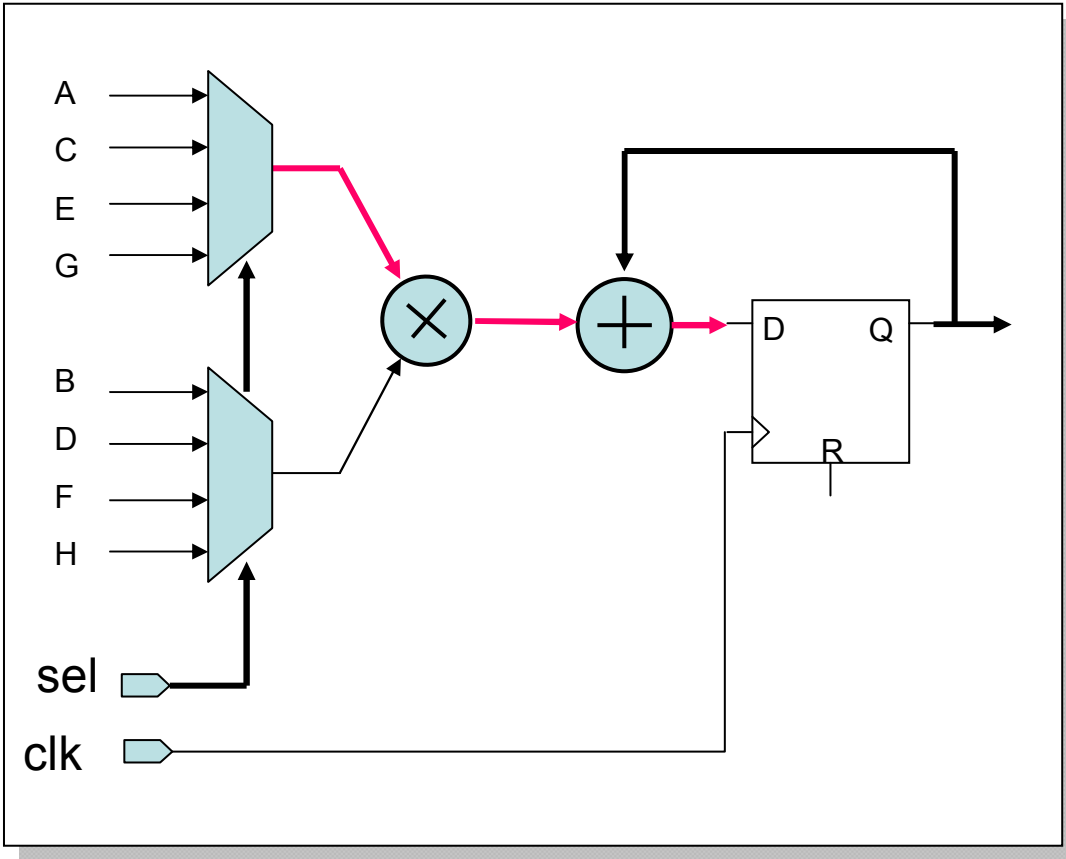
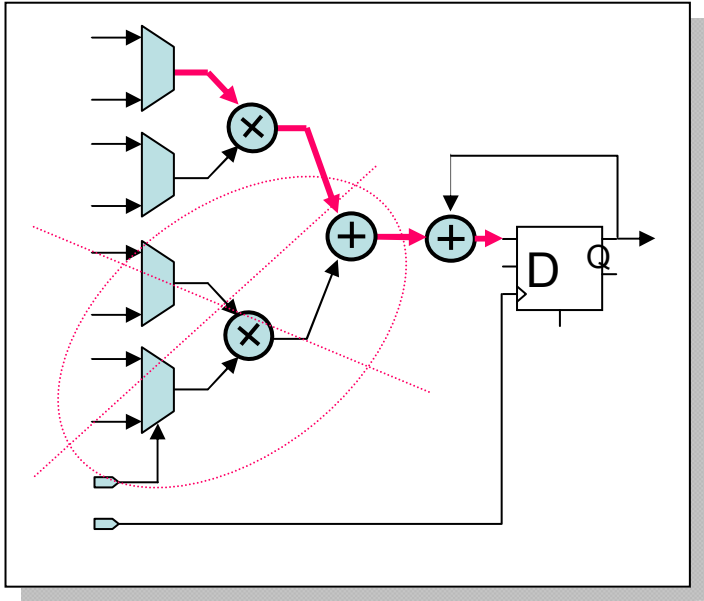

- * VLSI \leftrightarrow FPGA (use it or loose it!)
- * Architectural decision

Automatic Resource Sharing

Conditional assignment

```
if (B > C)
  then Y <= A + B;
  else Y <= A + C;
end if;
```

Logic Synthesis Option

Resource Sharing

OFF

ON

* VLSI <-> FPGA (use it or loose it!)

* Synthesis Tool decision

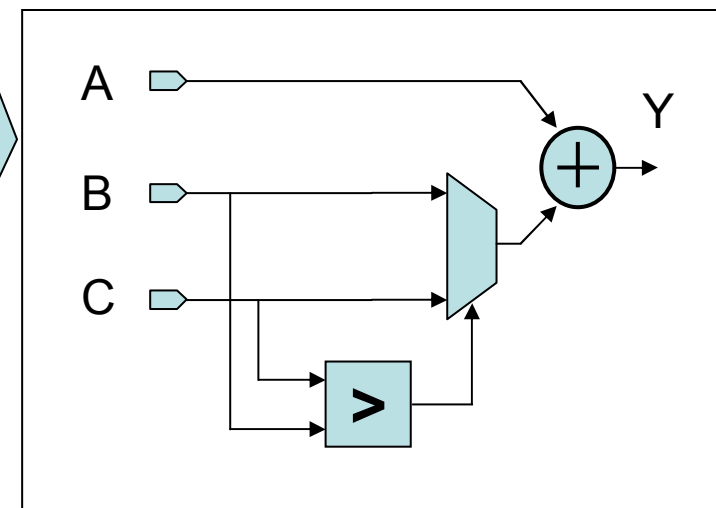
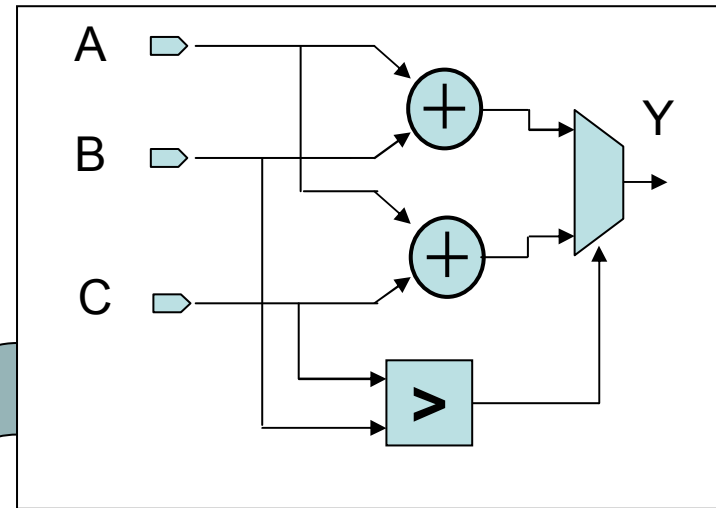

Primitives and Macros

Primitives

**Dedicated
hardware**

Memories

Multipliers

DLL, PLLs

microprocessors

Macros

**Software
implemented**

Adders

Multipliers

Multiplexers

microprocessors

Buses and Multiplexers: *a simple 2_to_1 MUX*

```
--conditional assignment  
Out_Mux <= A when SEL = '1' else B;
```

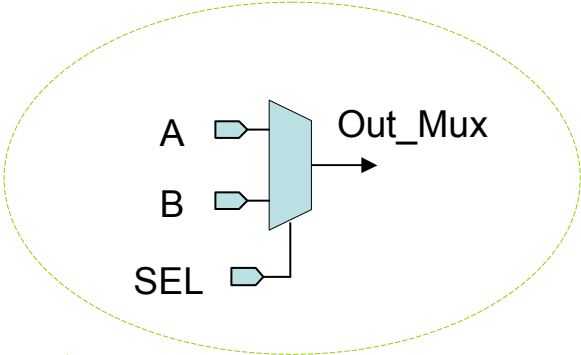

PRIMITIVE

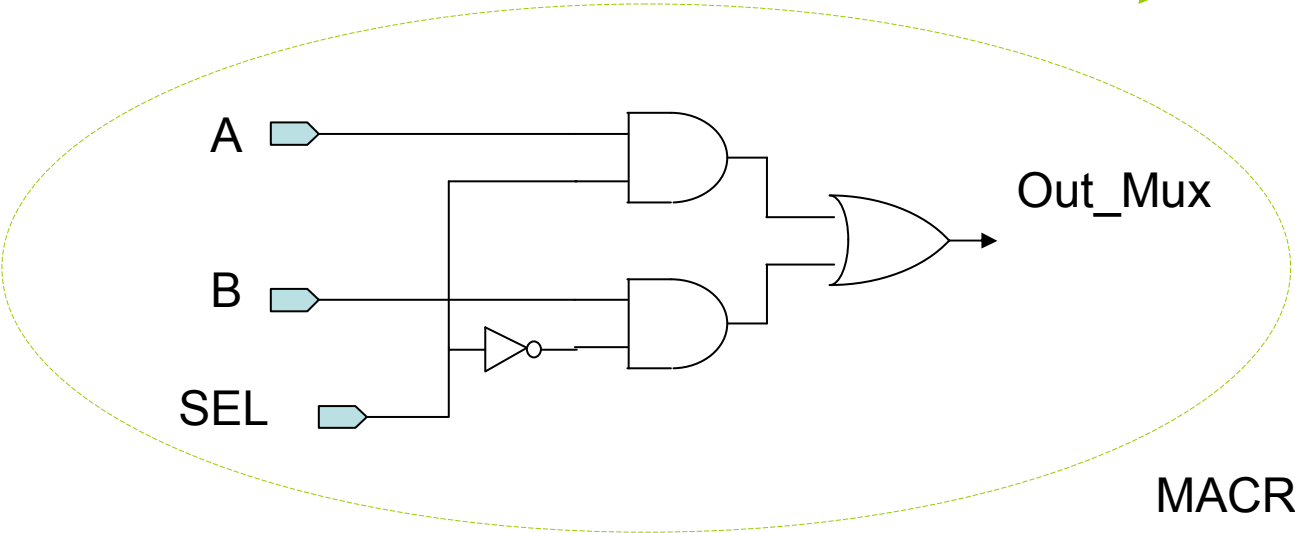

MACRO

Buses and Multiplexers: a 4_to_1 MUX

Behavioral VHDL

```
process (SEL, A, B, C, D)
begin
  case SEL is
    when "00" => Out_Mux <= A;
    when "01" => Out_Mux <= B;
    when "10" => Out_Mux <= C;
    when "11" => Out_Mux <= D;
    when others => Out_Mux <= A;
    --(?)
  end case;
end process;
```

Schematic (equivalent to structural VHDL)

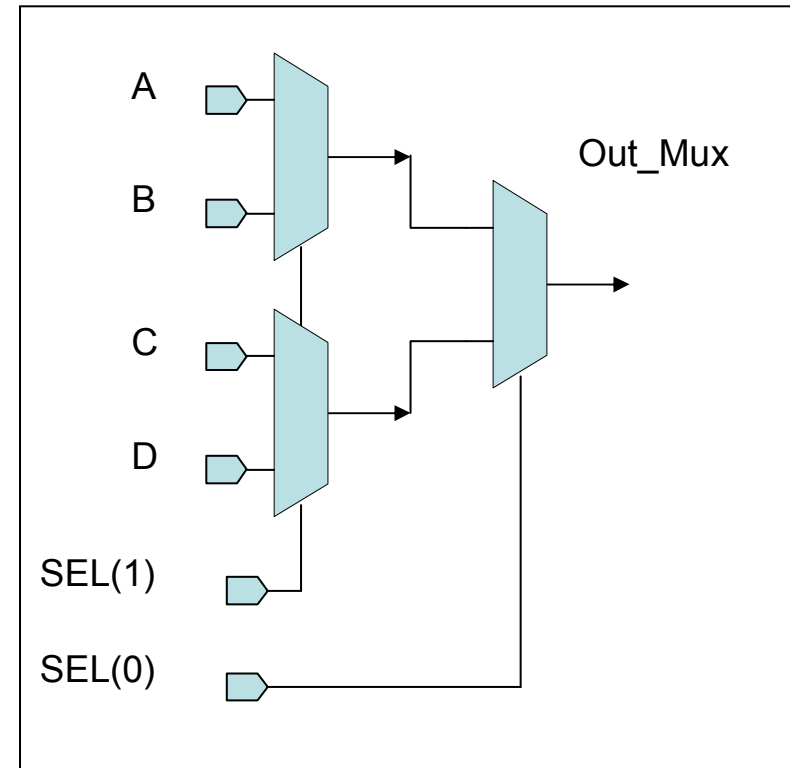

Buses and Multiplexers: *a many inputs MUX*

```
Out_Mux <= A when EN_A = '1' else 'Z';  
Out_Mux <= B when EN_B = '1' else 'Z';  
Out_Mux <= C when EN_C = '1' else 'Z';  
*  
*  
*
```

Be careful !!!
(potential shorts
and floating lines)

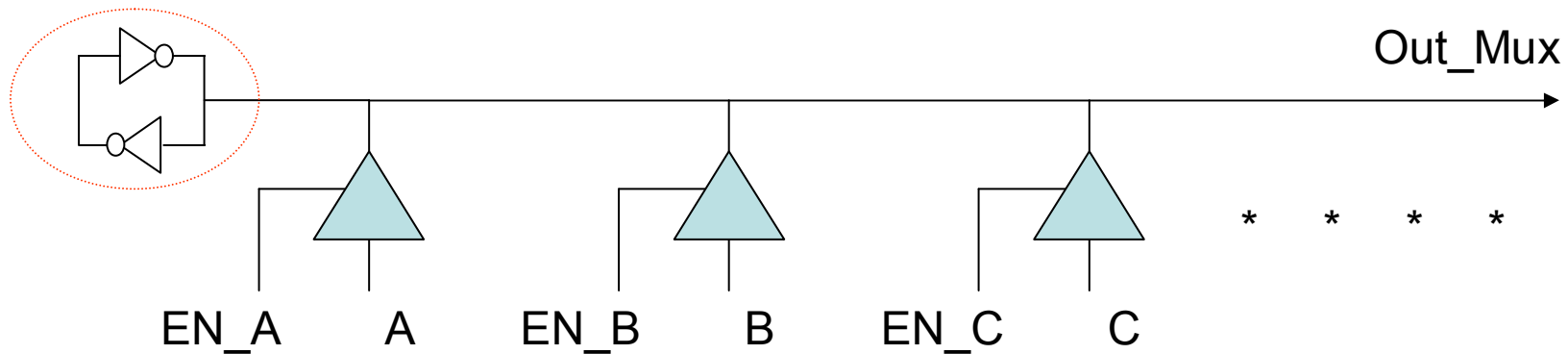

Who takes care of the mutual exclusion of EN_X ?

Part B. FPGA Design

- The synchronous design paradigm
- Unavoidable and Avoidable asynchronous designs
- Special asynchronous circuits
- Debugging Techniques
- Common mistakes
- Good design practices

The Ideal Synchronous Design

- The timing of the whole design is referred to a single free running clock

(or multiple clocks from a common source with perfectly controlled inter-clock phase)

The synchronous design paradigm

	Synchronous	Asynchronous
Debugging	Easier	Very difficult
Predictability	Deterministic	Non deterministic
Interface with a sync. environment	Naturally interfaced	Requires special circuitry
Power:	Variable depending on architecture	Probably lower (?)
Speed	Essentially given by the clock frequency and architecture	Higher (?). Closer to the maximum for a given activity
Area	(?) Depends on architecture	(?) Depends on architecture
Design Time	Shorter time. A proved methodology exists. Mainly based on critical paths.	Longer time. It requires more physical information and detailed analog simulations for accurate delays determination
Reliability	Robust	Must be extensively checked

Unavoidable asynchronous designs

- Metastability
- Debouncing
- Multiple (unrelated) clock domains
 - Resynchronization of signals
 - Updating flags
 - Gray and Johnson codes

Metastability

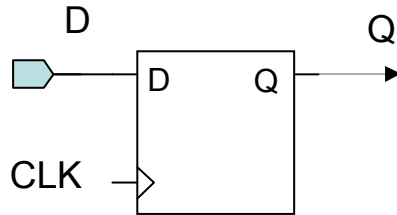

$$MTBF = \frac{e^{(C_2 \times t_{MET})}}{C_1 \times f_{CLOCK} \times f_{DATA}}$$

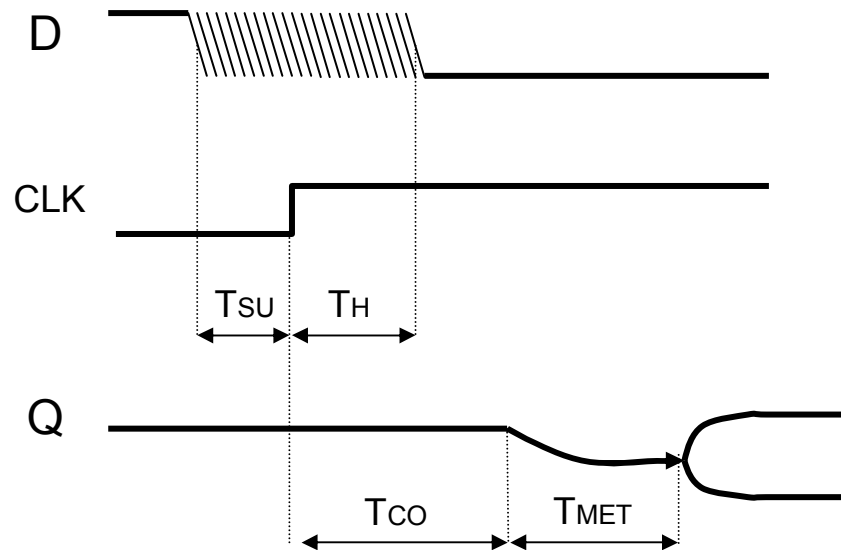

C1: represents metastability-catching setup time windows (likelihood of going metastable)

C2: is an indication of the gain-bandwidth product of the master latch in the flip-flop

T_{SU}: set up time

T_H: hold time

T_{CO}: clock to output delay

T_{met}: settling time

The clock skew problem

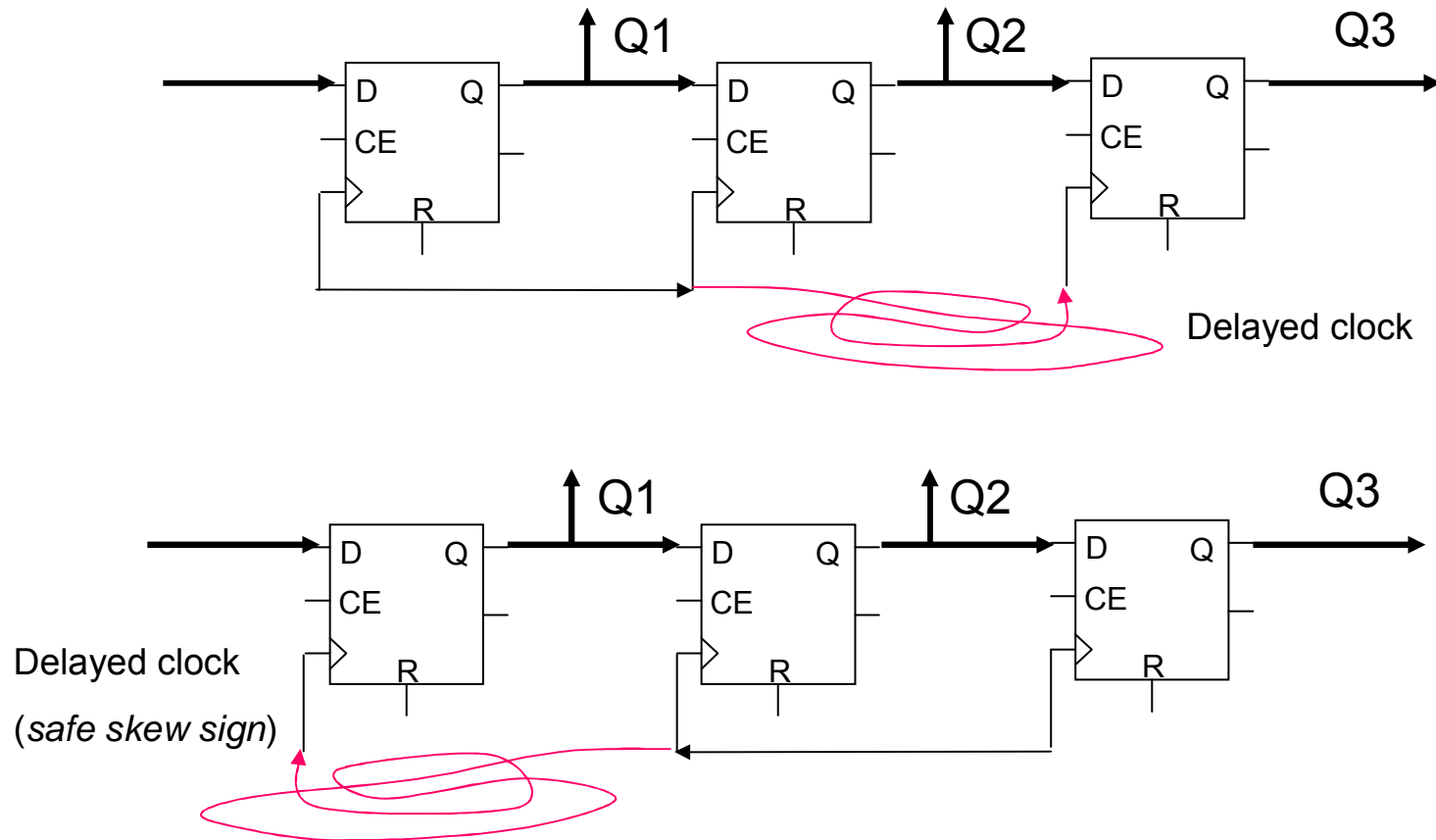

Examples of avoidable asynchronous circuits

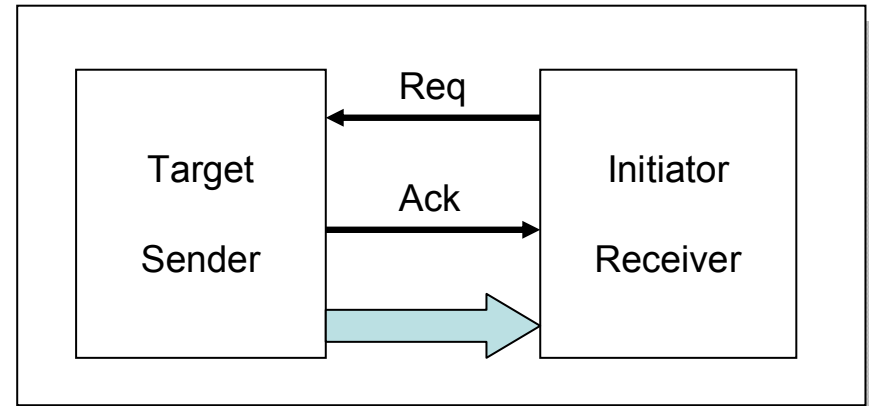
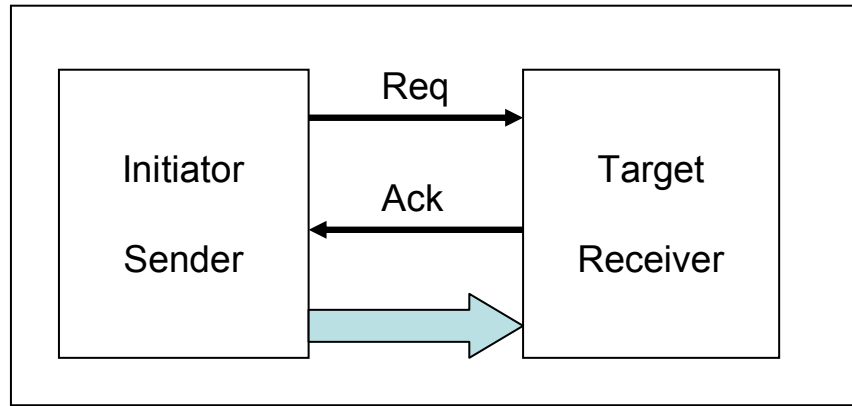
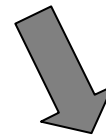
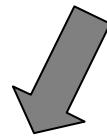
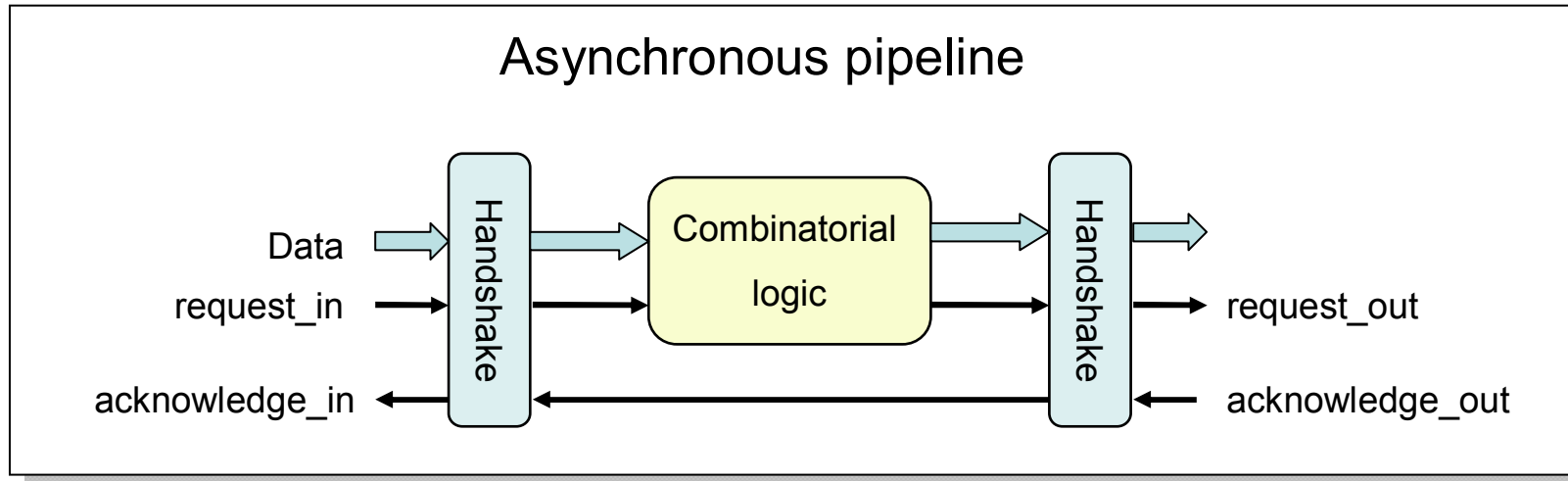

More examples of avoidable asynchronous circuits

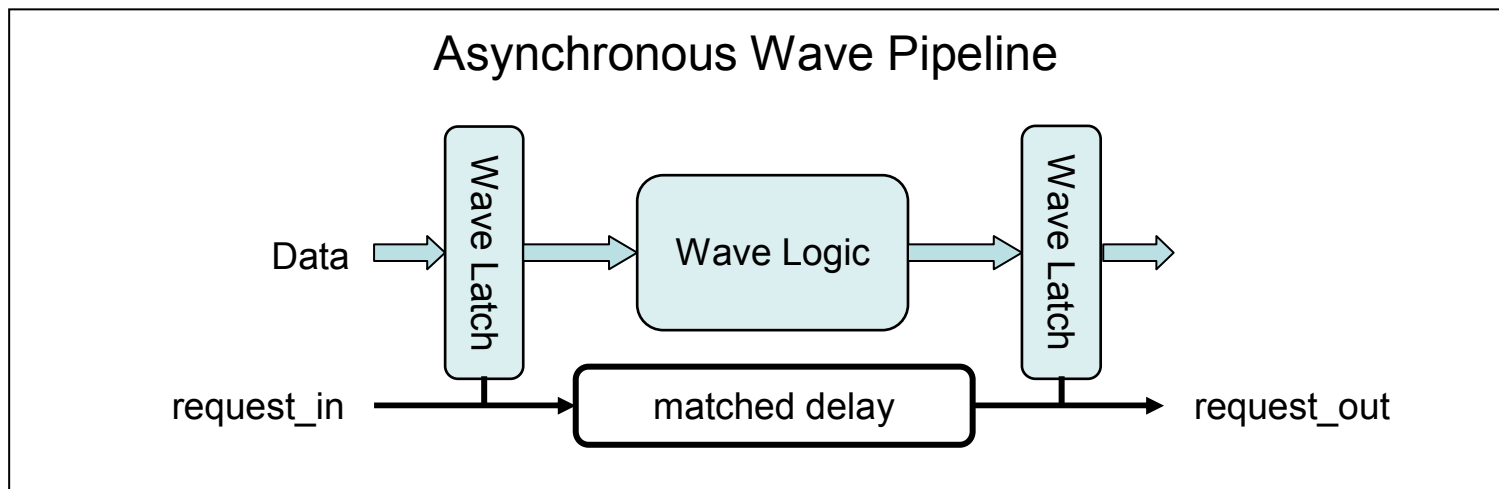
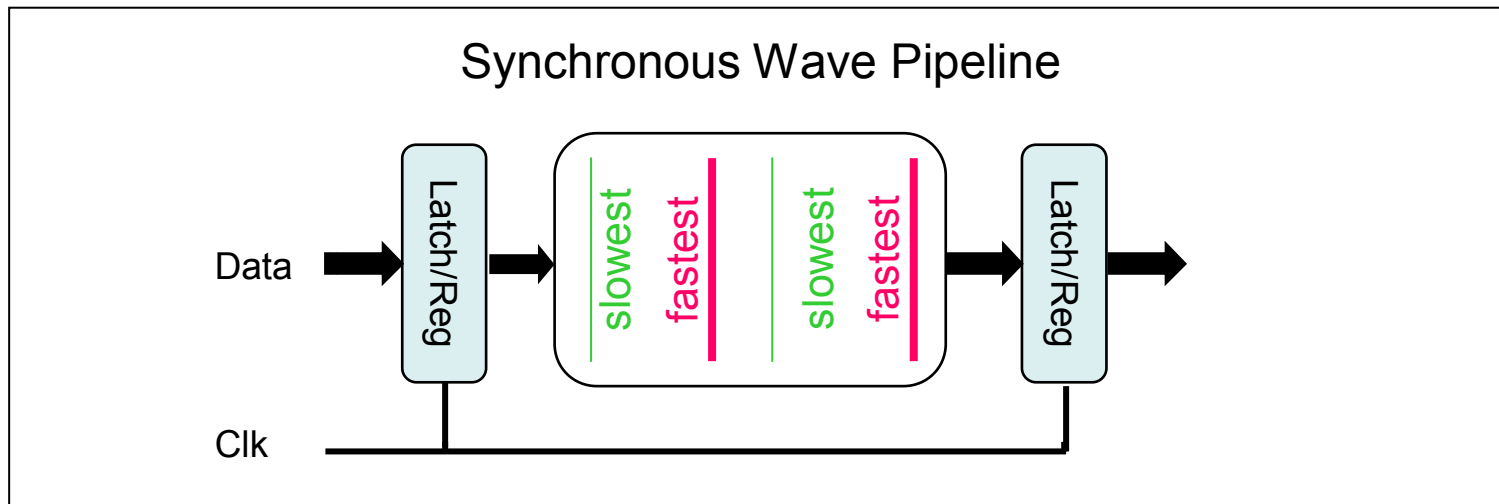

Common examples of unavoidable asynchronous circuits

Context	Examples	useful circuits
External inputs	Push buttons, Switches, Interrupts, etc	I. Debouncing II. Stabilizer
Microprocessor interface	Co processing with DSP, Microc., GPP	III. Flancter
Multiple clock domains	Glue logic in complex systems	IV. Clock switching V. Gray codes

I. Debouncing (For edge sensitive signals)

```
-- Single shot pulse generator
Process (clk, reset)
begin
  if (reset = '1') then
    Q1 <= '0';
    Q2 <= '0';
    Q3 <= '0';
  elsif (clk'event and clk = '1') then
    Q1 <= IN1;
    Q2 <= Q1;
    Q3 <= Q2;
  end if;
end process;

OUT1 <= Q1 and Q2 and (not Q3);
```

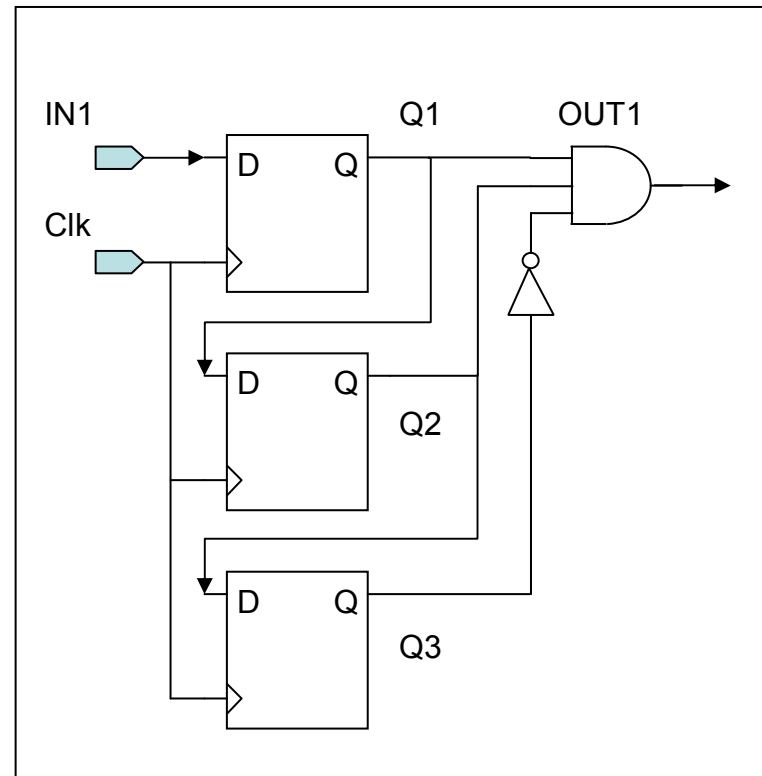

What about glitches ?

What happens if the **out1** assignment is done inside the process?

II. Stabilizer (For *level* sensitive signals)

```
Process (clk, reset)
begin
  if (reset = '1') then
    Q1 <= '0';
    Q2 <= '0';
    Q3 <= '0';
  elsif (clk'event and clk = '1') then
    Q1 <= IN1;
    Q2 <= Q1;
    Q3 <= Q2;
  end if;
end process;

OUT1 <= Q1 when ((Q1=Q2) and (Q2=Q3));
```

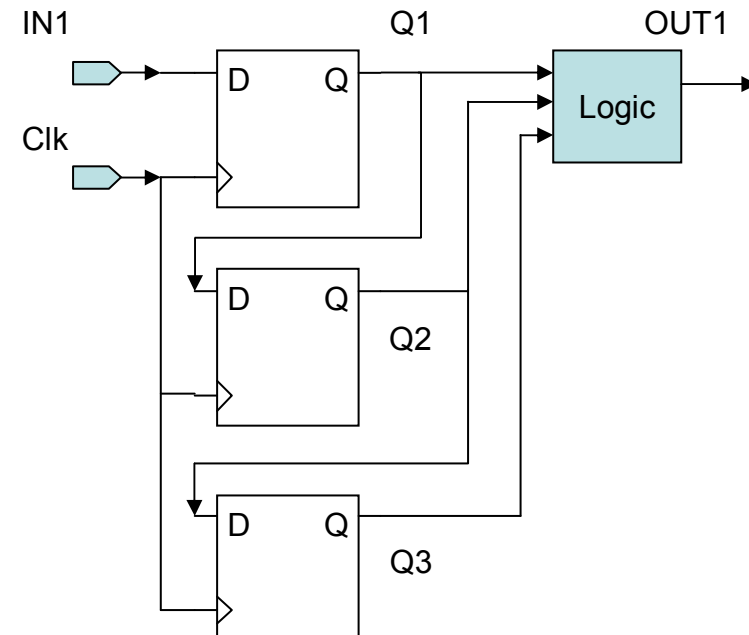

What about glitches ?

What about latch inference on OUT1 ?

What happens if the *out1* assignment is done inside the process?

A possible FPGA ↔ Microprocessor handshaking mechanism

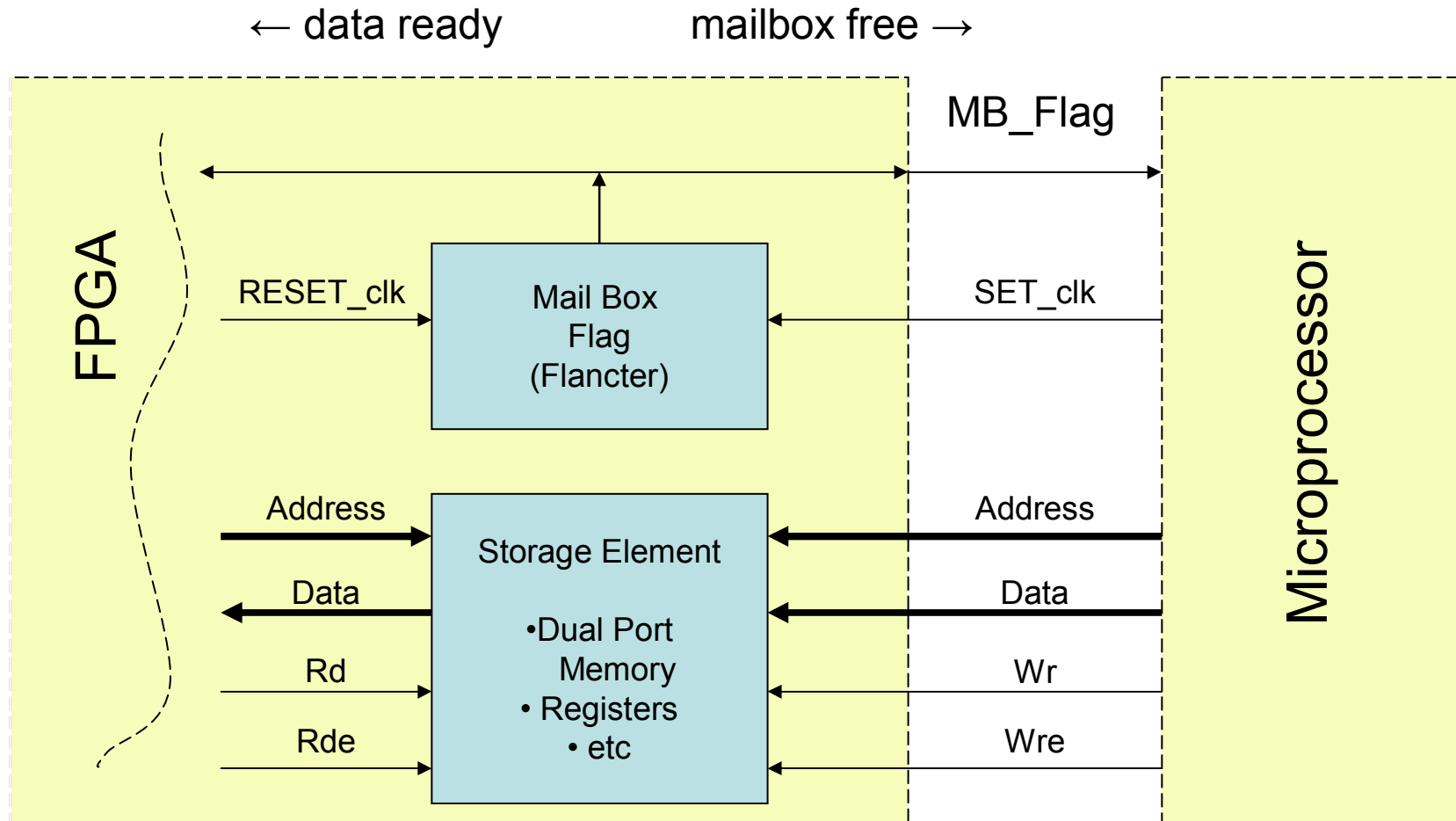

III. Flancter

(setting and clearing a flag with the edges of two signals)

Timing diagram

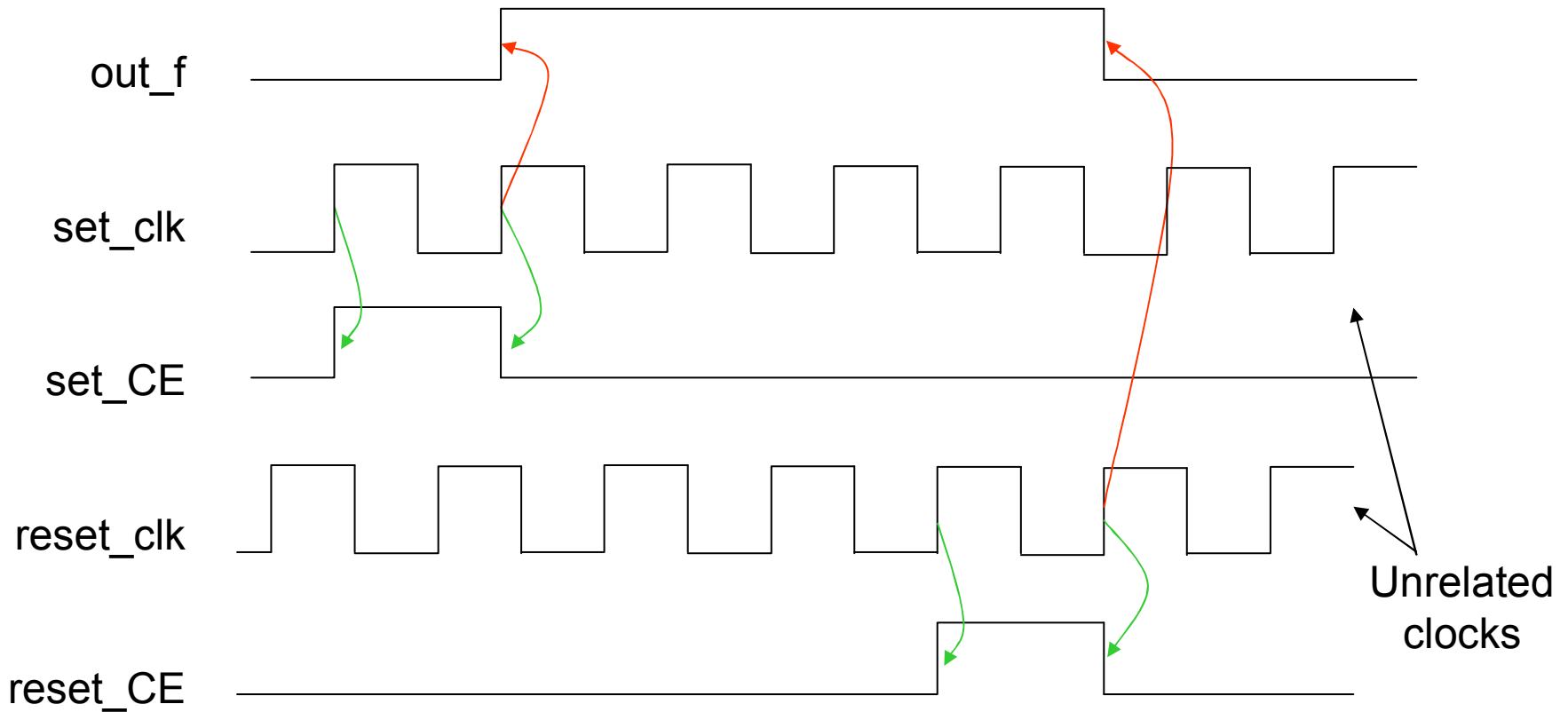

III. Flancter

(setting and clearing a flag with the edges of two signals)

```
-- SET PROCESS:  
Process (set_clk, set_CE)  
begin  
  if (set_CE = '1') then  
    elsif (set_clk'event and set_clk = '1')  
      then  
        out_f <= '1';  
      end if;  
  end if;  
end process;  
  
-- RESET PROCESS:  
Process (reset_clk, reset_CE)  
begin  
  if (reset_CE = '1') then  
    elsif (reset_clk'event and reset_clk = '1')  
      then  
        out_f <= '0';  
      end if;  
  end if;  
end process;
```

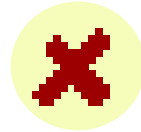

Try a solution based on standard cells for design portability

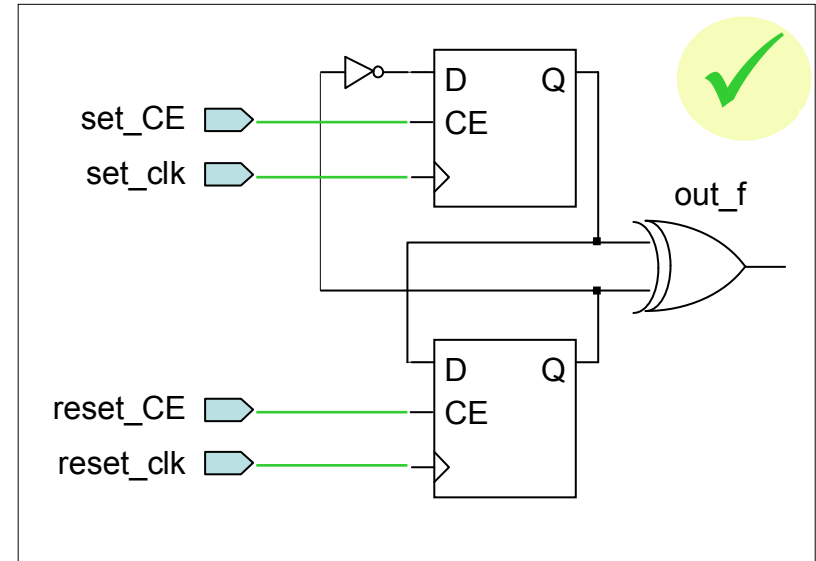

Synthesis ERROR:Xst:528 - Multi-source on signal <out_f>

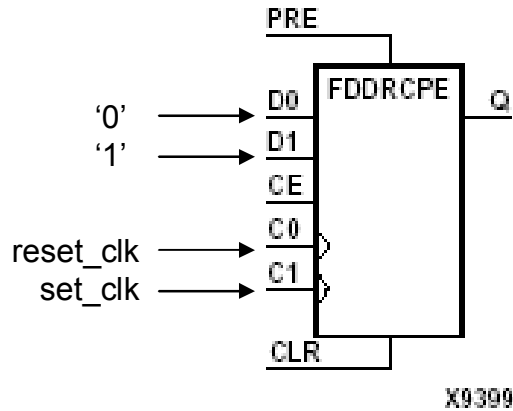

Inputs							Outputs
C0	C1	CE	D0	D1	CLR	PRE	Q
X	X	X	X	X	1	0	0
X	X	X	X	X	0	1	1
X	X	X	X	X	1	1	0
X	X	0	X	X	0	0	No Chg
↑	X	1	D0	X	0	0	D0
X	↑	1	X	D1	0	0	D1

Usage: For HDL, this design element is instantiated rather than inferred.

--VHDL Instantiation Template

```

FDDRCPE_INSTANCE_NAME : FDDRCPE
  port map (Q => user_Q,
            C0 => user_C0,
            C1 => user_C1,
            CE => user_CE,
            CLR => user_CLR,
            D0 => user_D0,
            D1 => user_D1,
            PRE => user_PRE);

```

- 1) A suitable primitive could exist but could not be inferred from the HDL code. Synthesis Tools may not be mature enough for this.
- 2) Explore special resources (primitives) and manually instantiate them wherever is possible for max performance

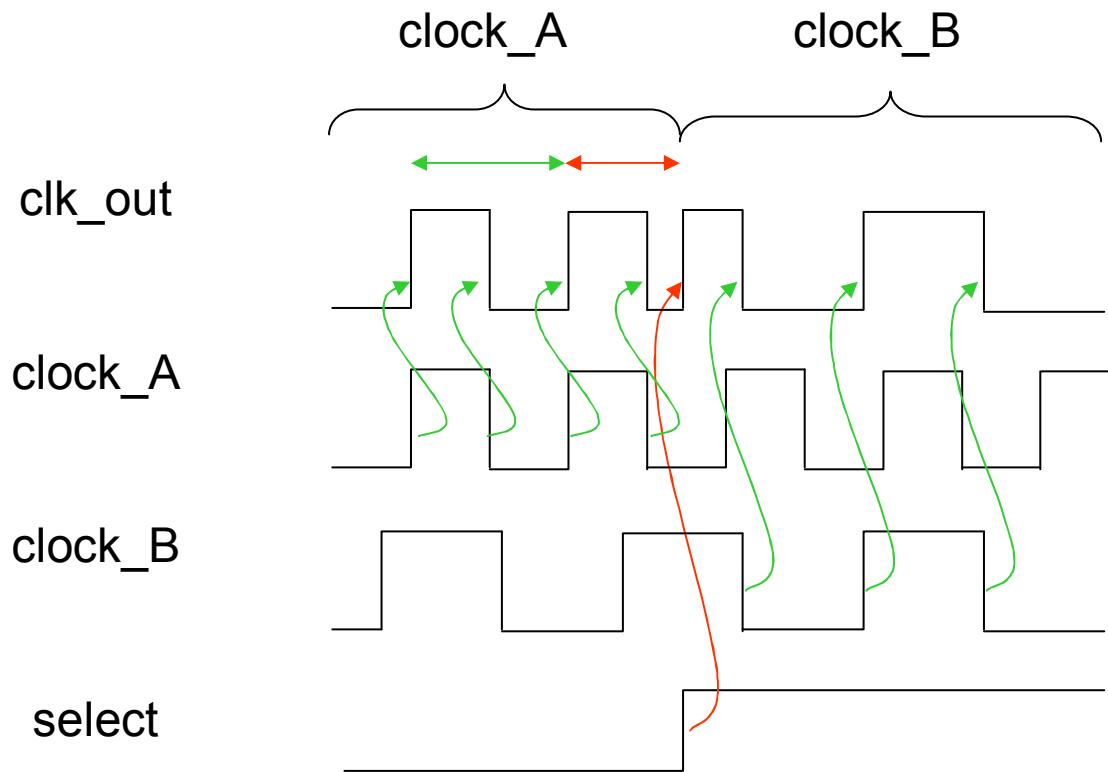

IV. Clock switching

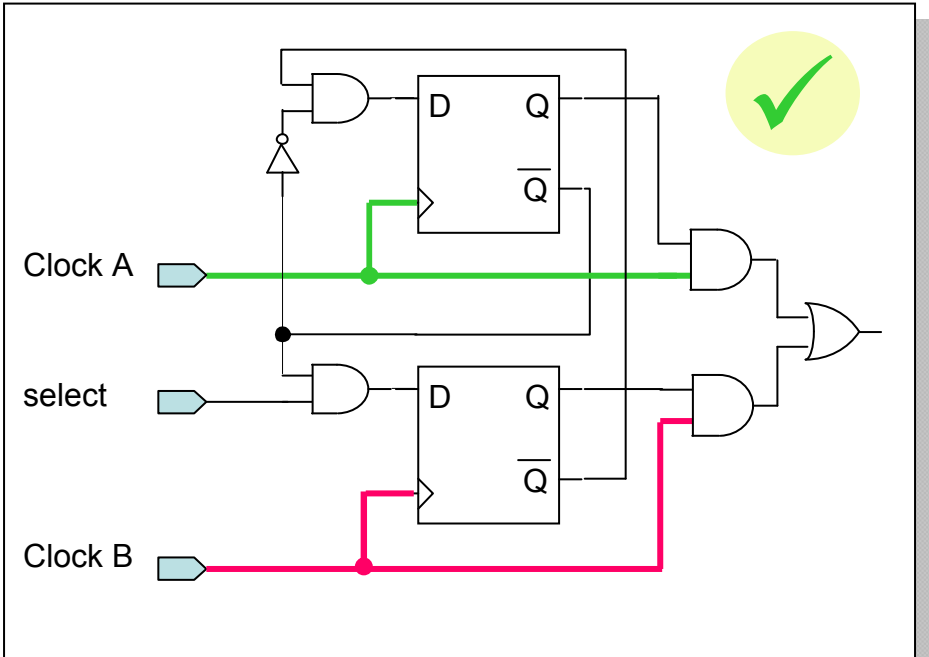
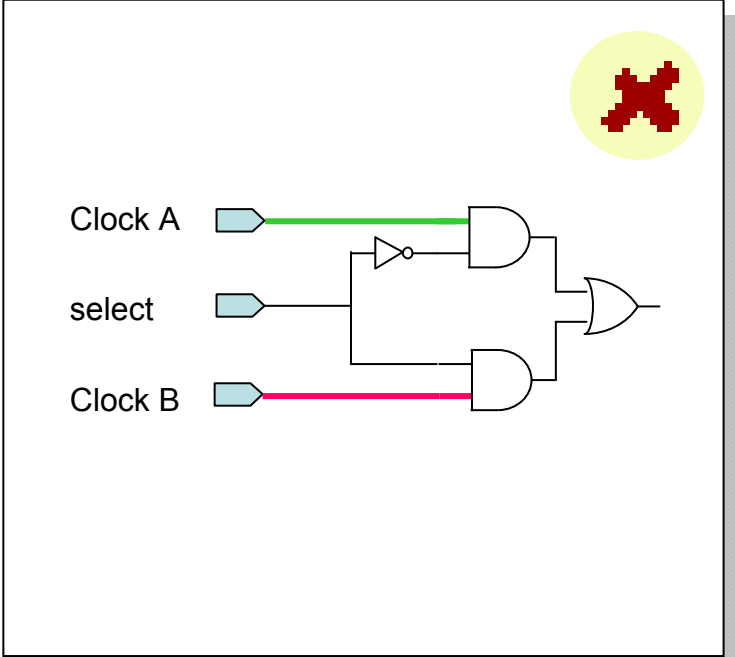

Transmitting parallel data with unrelated clocks

If the receiver clock is always faster than the transmitter clock
 (e.g. $f_{receiver} > 3 * f_{transmitter}$)

This only grants data integrity.
 Doesn't prevent multiple reading or overwriting

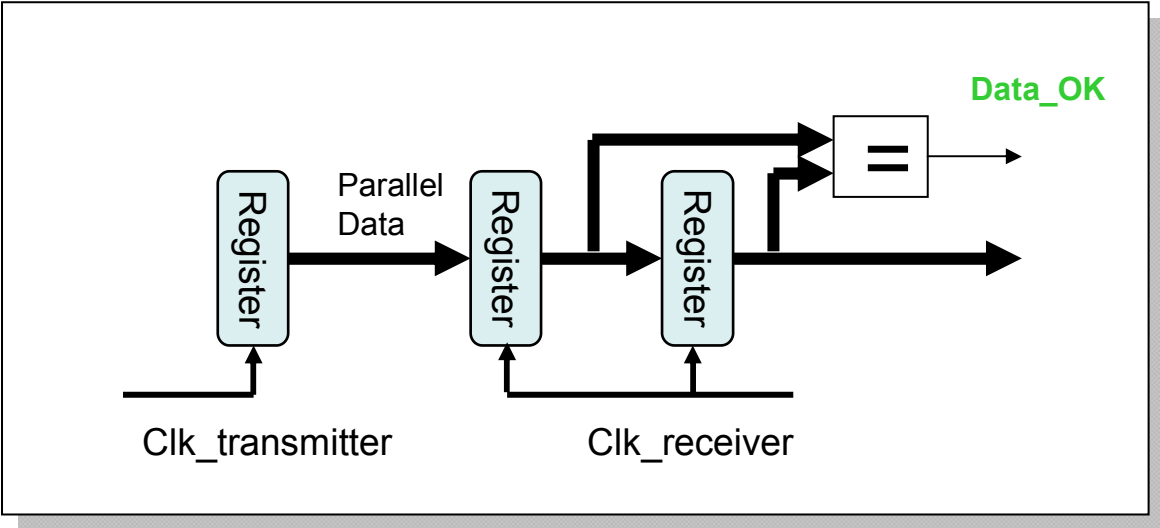

For completely unrelated clocks and sequential data transfer use Asynchronous FIFOs

Be sure the reading average frequency is equal or higher than the writing frequency.
 (ave. freq fluctuations vs fifo length)

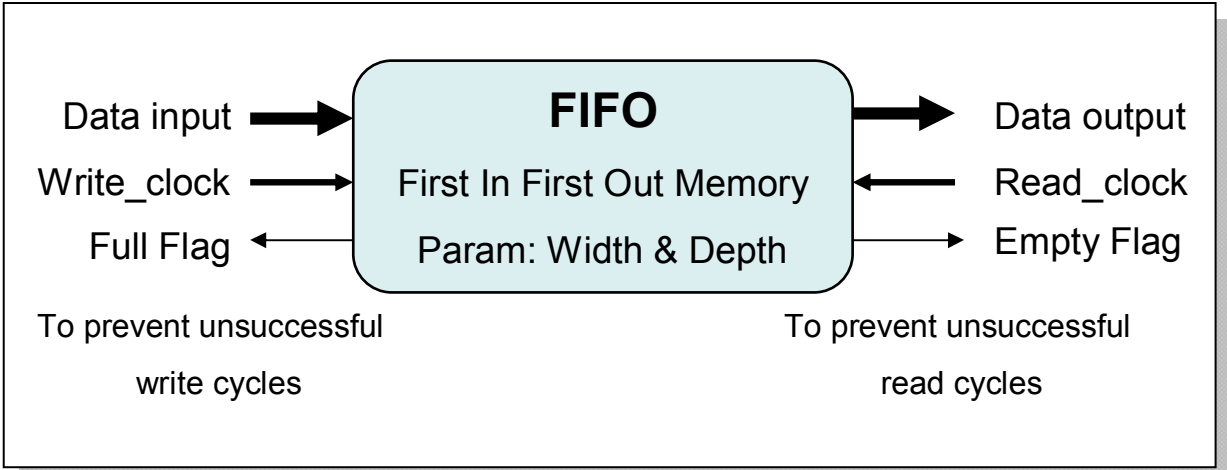

VI. Gray code

Binary

000
001
010
011
100
101
110
111

The MSB changed while the other didn't yet

The transmitted word is not the previous one neither the new one

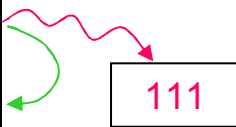

Gray

000
001
011
010
110
111
101
100

Only one bit changed

The transmitted word is the previous one or the new one

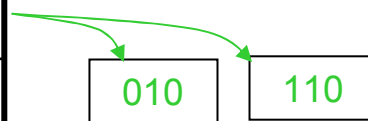

Johnson

000
001
011
111
110
100

* Useful for sequential data as in counters, sequencers, etc

* All bits are stable except the only one that changes.

Binary \leftrightarrow Gray Conversion

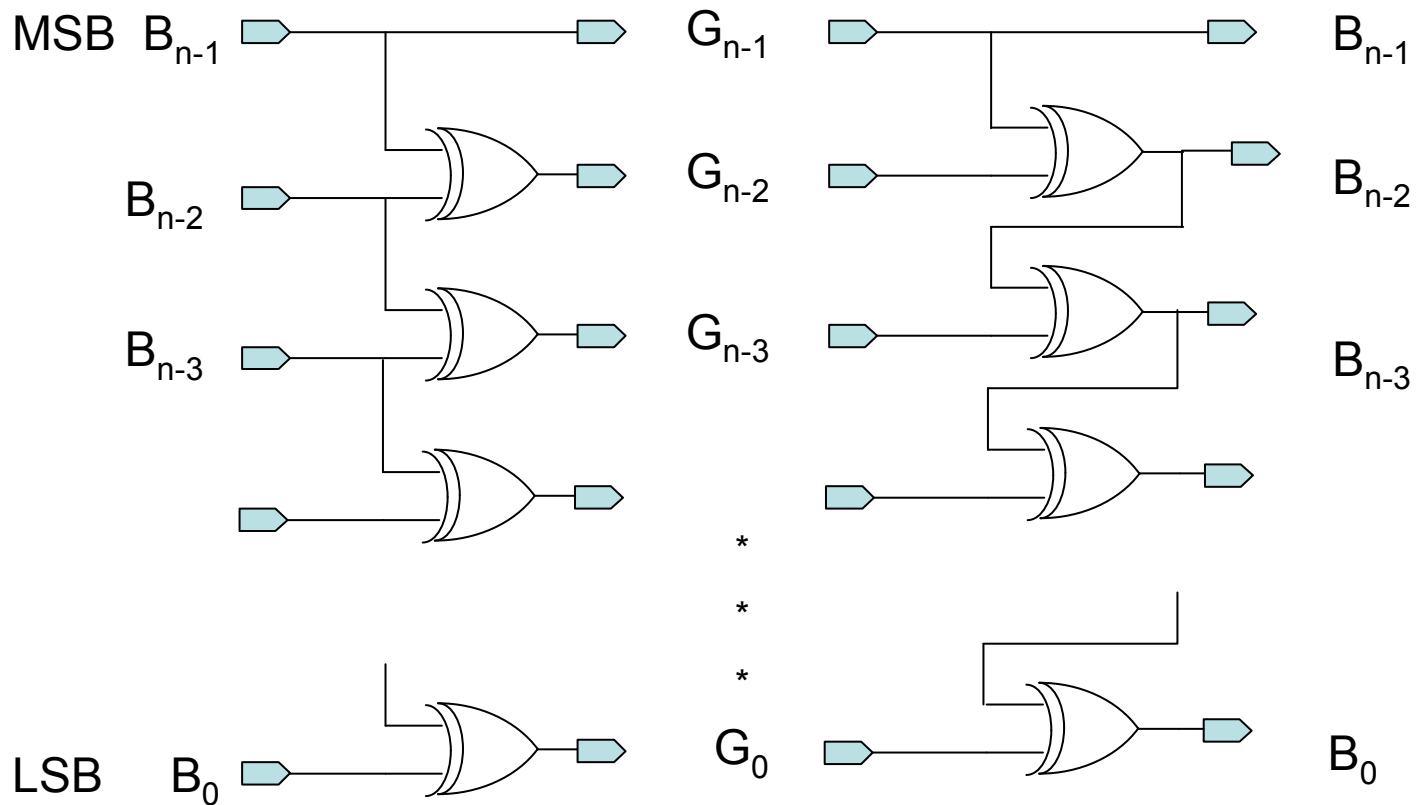

Which are the critical paths?

Johnson counter (*twisted-ring counter*)

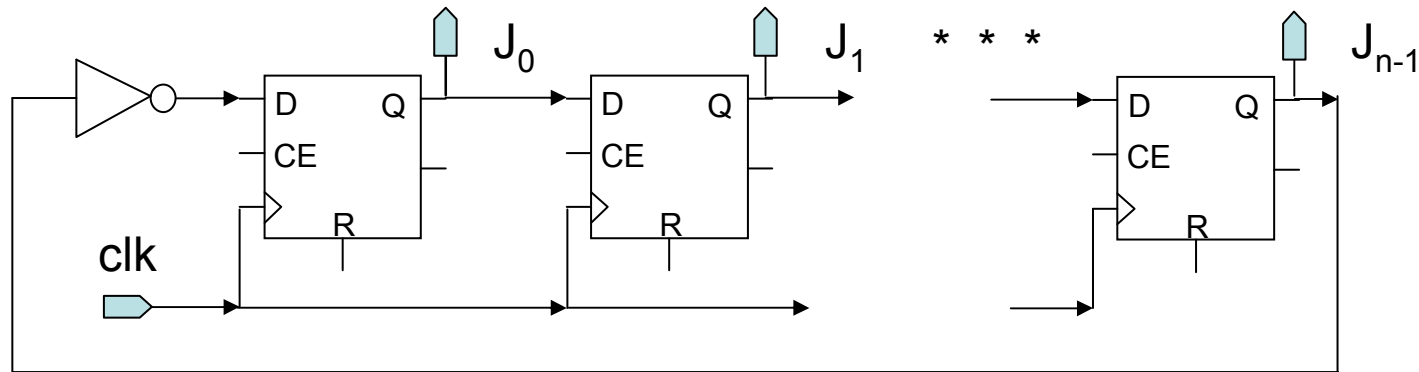

```
Process (clk, reset)
begin
  if (clk'event and clk = '1') then

    J <= J(WIDTH-2 downto 1) & not J(0);

  end if;
end process;
```

Fast, simple and glitch-free

Clocking Strategies (VERY IMPORTANT)

Combinatorial Synthetic Clock

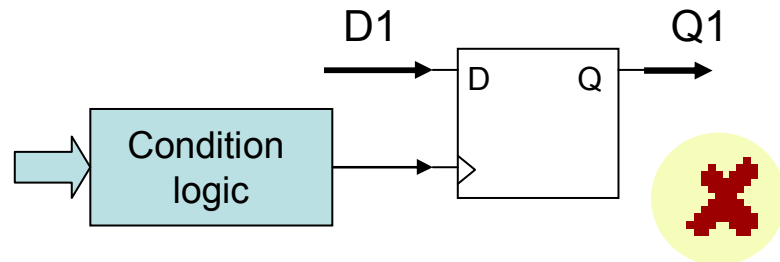

Free running clock + Gating

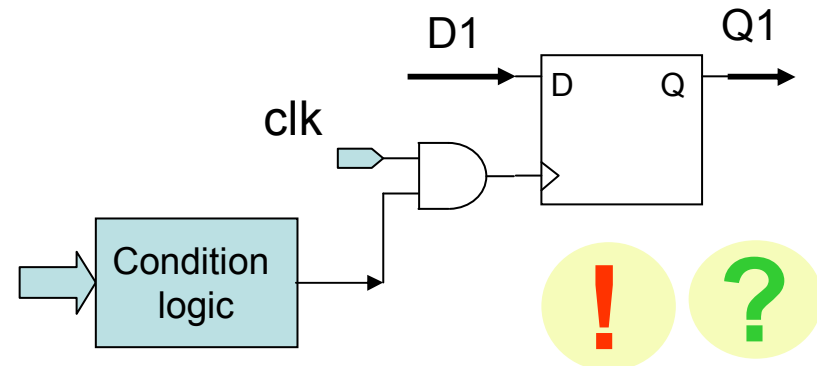

Registered Synthetic Clock

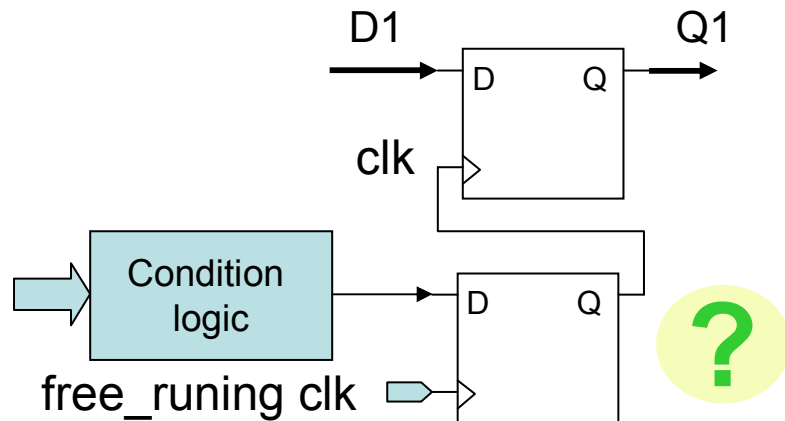

Free running clock + Clock enable

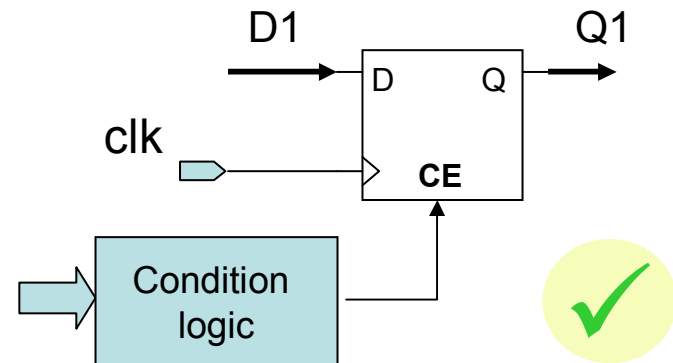

Debugging Techniques

- Seeing and controlling internal signals
- FSM debugging
- In chip logic analysis

Seeing and controlling internal signals

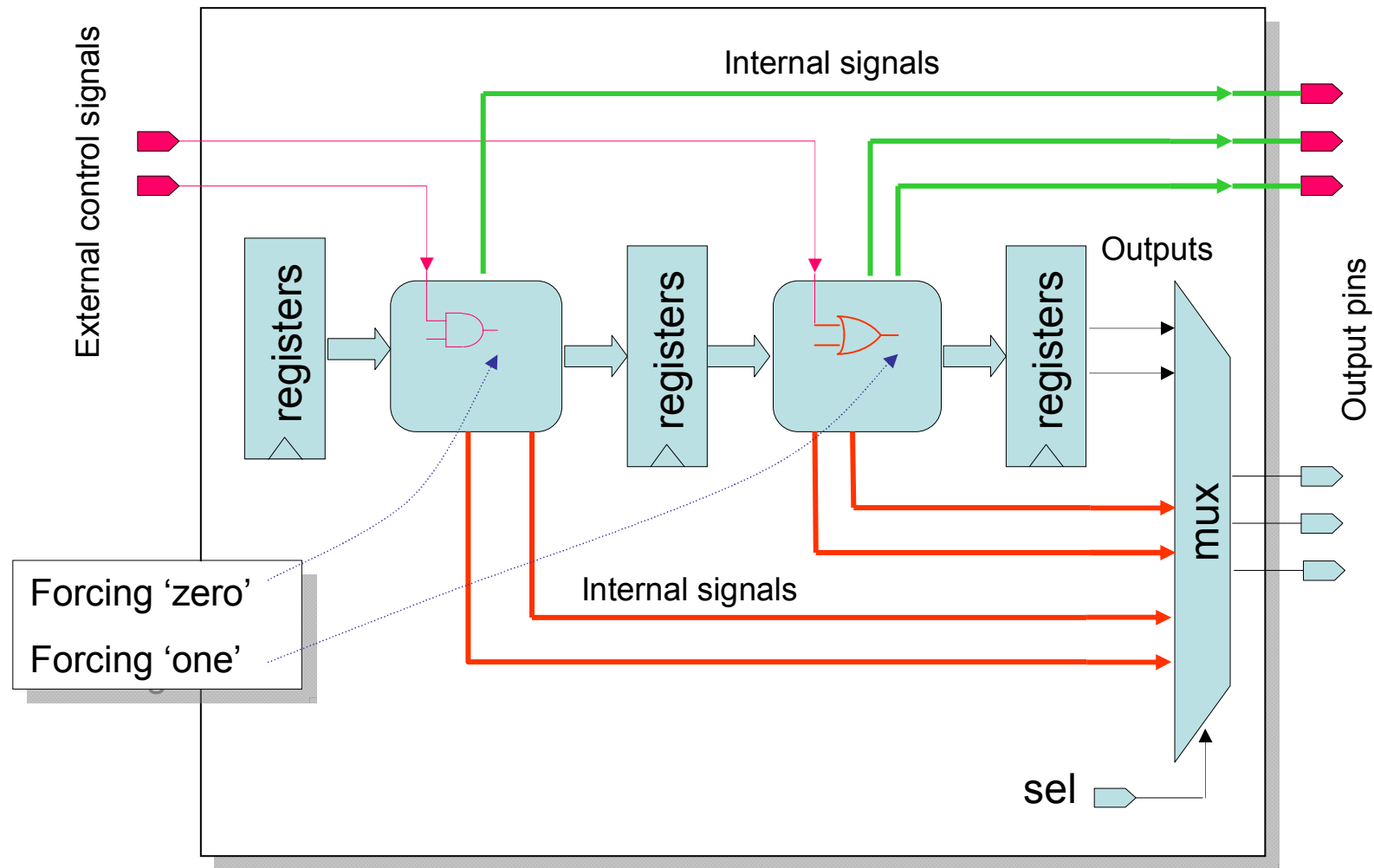

Debugging a FSM

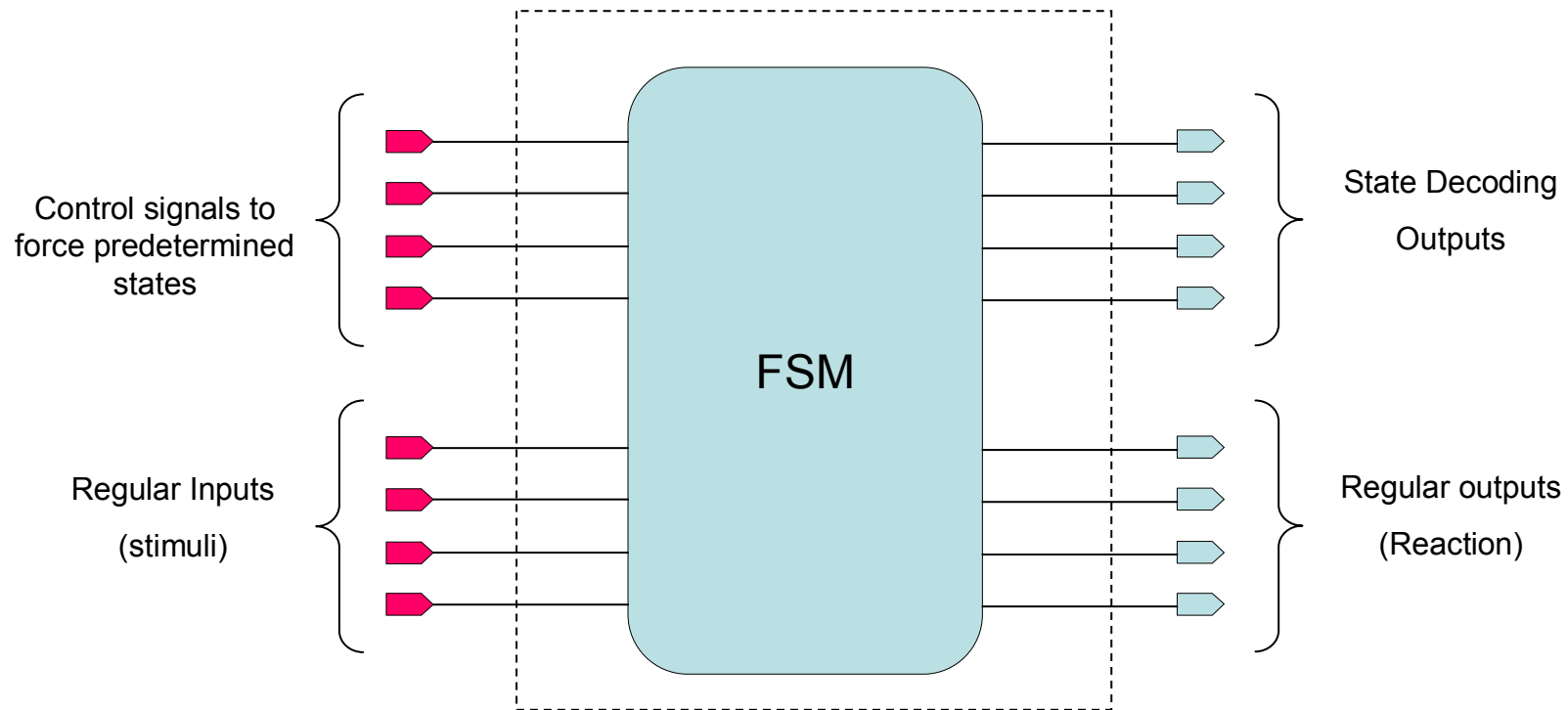

- Design a hardware mechanism to force predetermined states (reset)
- Foresee outputs to decode and recognize those states and eventually "others"

On Chip Logic Analysis

- Virtual Logic Analyzer -

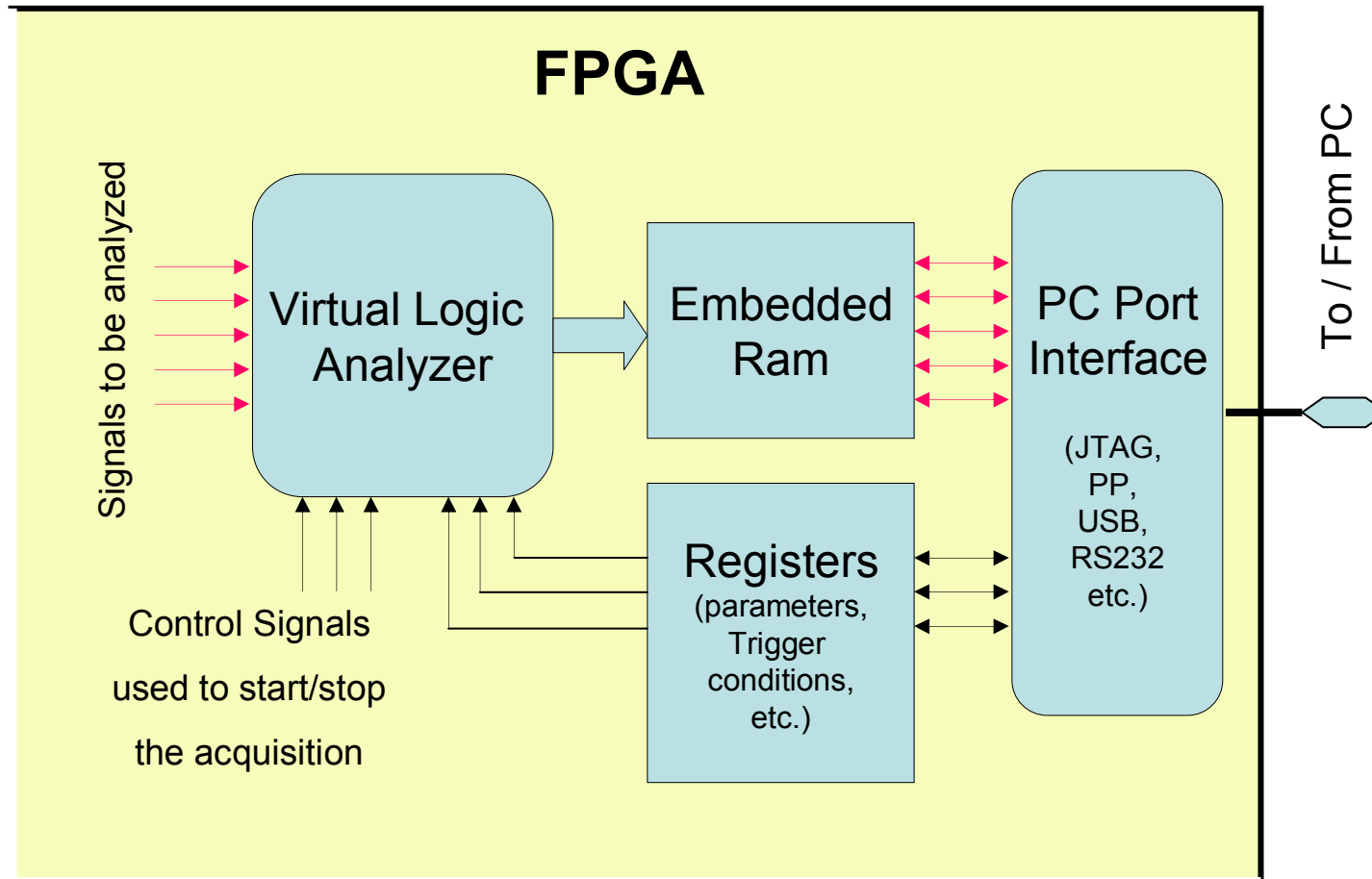

Most common mistakes

- Incomplete/Unclear/Wrong Specifications. Poor documentation
- Lack of a verification plan
- Debugging not foreseen
 - No visibility of internal signals/states
 - No hardware initialization mechanism
- Clocking
 - Asynchronous approach
 - Skew not well controlled
 - Clock enabling
- Metastability
 - Bouncing/dirty input signals
 - Asynchronous input signals
 - Multiple unrelated clock domains

Good design practices 1

- Adopt a rigorous fully synchronous design approach whenever possible (clock enabling, only one free running clock, pipeline)
- Adopt a clear modular and hierarchical design approach to facilitate verification and reusability of functional blocks
- Ensure external control and visibility of internal signals for debugging
- Use primitives for performance
- Don't use primitives for portability
- Use safe FSM (“*others*” states)
- Use specific resources for clocks (dll, pll, clock buffers)

Good design practices 2

- Synchronize all external inputs (and debounce and stabilize them if necessary)
- Resynchronize internal signals between unrelated clock domains
- Provide a hardware mechanism to port the system to a well known initial state (resets)
- Prepare a good documentation: precise, exhaustive and easy readable
- Check carefully the pad assignment report after implementation !

• And the most important...



Cross your fingers
before
applying power !!!