



**The Abdus Salam
International Centre for Theoretical Physics**



2065-4

**Advanced Training Course on FPGA Design and VHDL for Hardware
Simulation and Synthesis**

26 October - 20 November, 2009

Digital CMOS Design (contd.)

Pirouz Bazargan-Sabet
*LP6-Department ASIM
University of Pierre and Marie Curie VI
4, place Jussieu, 75252 Paris Cedex 06
France*

Outline

■ Digital CMOS design

- Boolean algebra
- Basic digital CMOS gates
- **Combinational and sequential circuits**
- Coding - Representation of numbers

CMOS Circuits

How can I design a digital circuit ?

- A set of gates (cell library)

combinational gates

memory elements



CMOS Circuits

How can I design a digital circuit ?

- Method to design combinational circuits

Karnaugh table (local optimization)

no method for global optimization

 synthesis tools

CMOS Circuits

How can I design a digital circuit ?

- Specify the circuit

Combinational circuit : Boolean functions

Sequential circuit ?



CMOS Circuits

Sequential Circuit

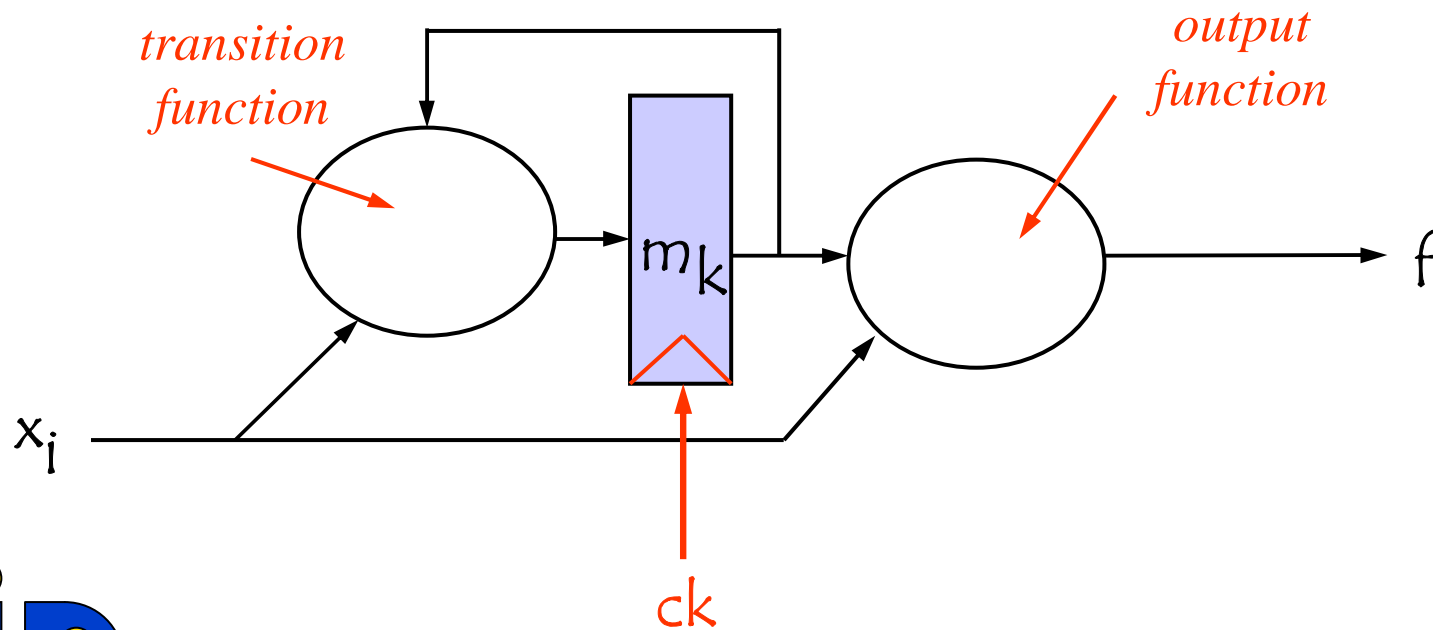

CMOS Circuits

How can I design a sequential circuit ?

I need a method to go from a black box to a white box

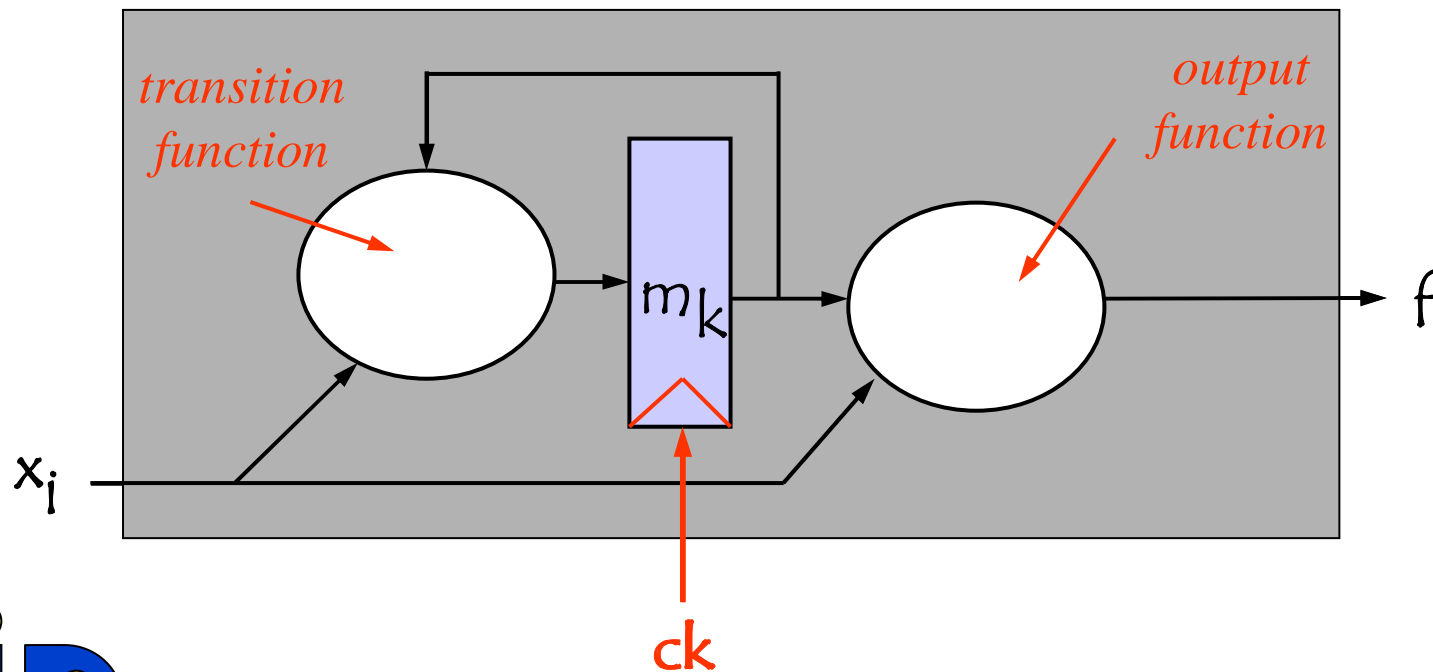

CMOS Circuits

How can I design a sequential circuit ?

The starting point (what I know)

What the circuit is supposed to do

Capture this knowledge into a
representation that can be
transposed into Boolean functions

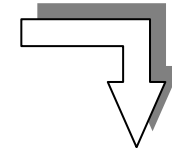

The aim

How it will do it

number of required
memory elements



CMOS Circuits

Representation of a sequential circuit ?

● State graph

G = (X, Y, S, T,

-) X : input variables
- Y : output variables
- S : states
- T : transitions
- : output set conditions



CMOS Circuits

○ **G** = (X, Y, S, T,
○)

T : set of transitions

$t \in T, \quad t = (s, s', f)$

$s \in S$: source state

$s' \in S$: target state

$f \in \mathbf{B}_n$: transition condition



CMOS Circuits

○ **G** = (X, Y, S, T,
O)

O : output set conditions

$o \in O, \quad o = (y, s, c)$

$y \in Y$: output variable

$s \in S$: state

$c \in \mathbf{B}_n$: output set condition



CMOS Circuits

- Let consider a graph $\mathbf{G} = (X, Y, S, T, O)$

Graphic representation of \mathbf{G}

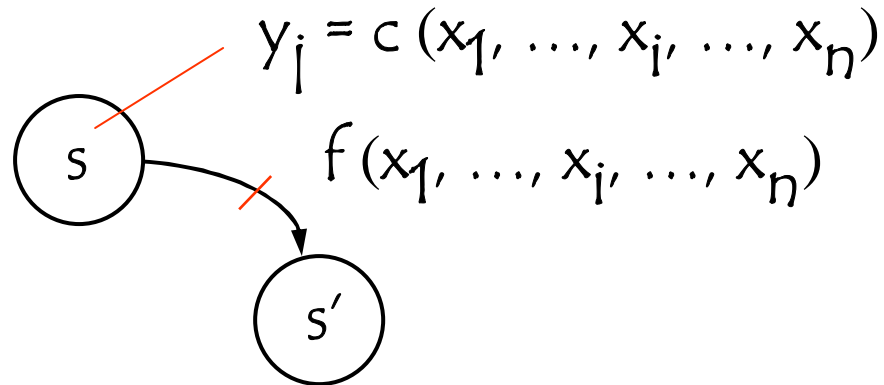

CMOS Circuits

Representation of a sequential circuit ?

- State graph

Transpose into a graphic representation the expected behavior of a sequential system

$$\mathbf{G} = (X, Y, S, T, O)$$



CMOS Circuits

Example

Two signals a , b each transmitting a series of bits (1 bit at a cycle)

Design a system that sets a flag d if the value transmitted by a is different than b



CMOS Circuits

Example

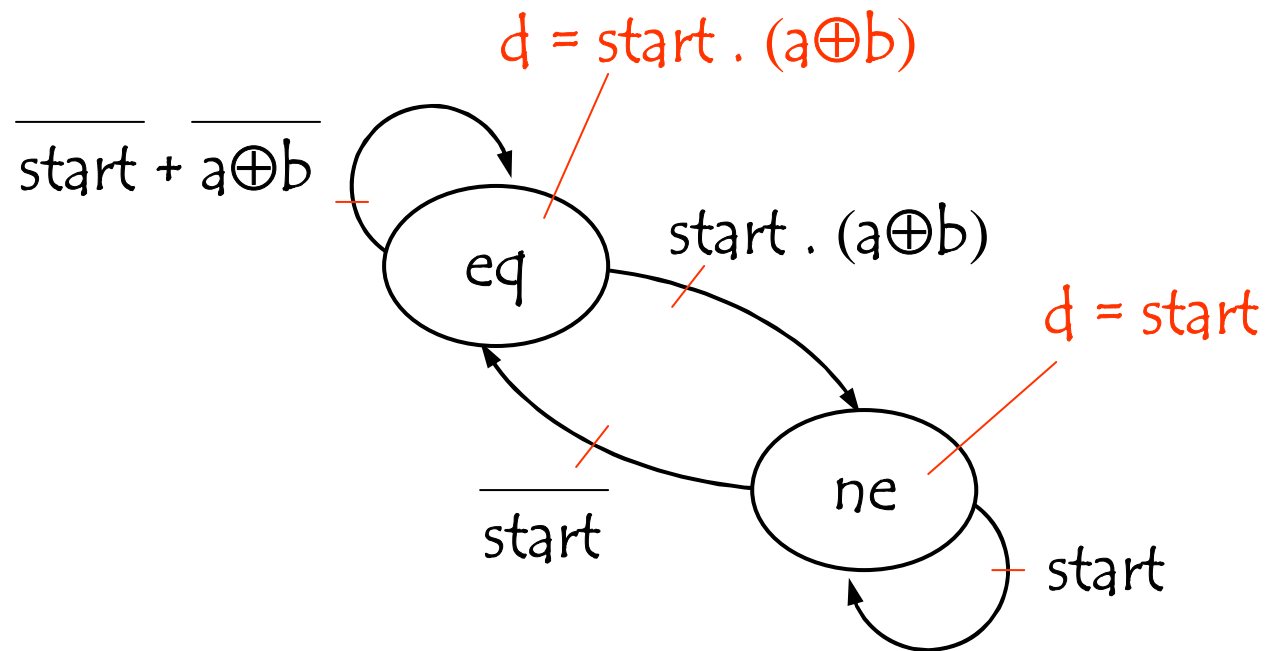

CMOS Circuits

Representation of a sequential circuit ?

- State graph

$$\mathbf{G} = (X, Y, S, T, O)$$

○
define the number of memory elements
required to represent $S : M$

CMOS Circuits

Example

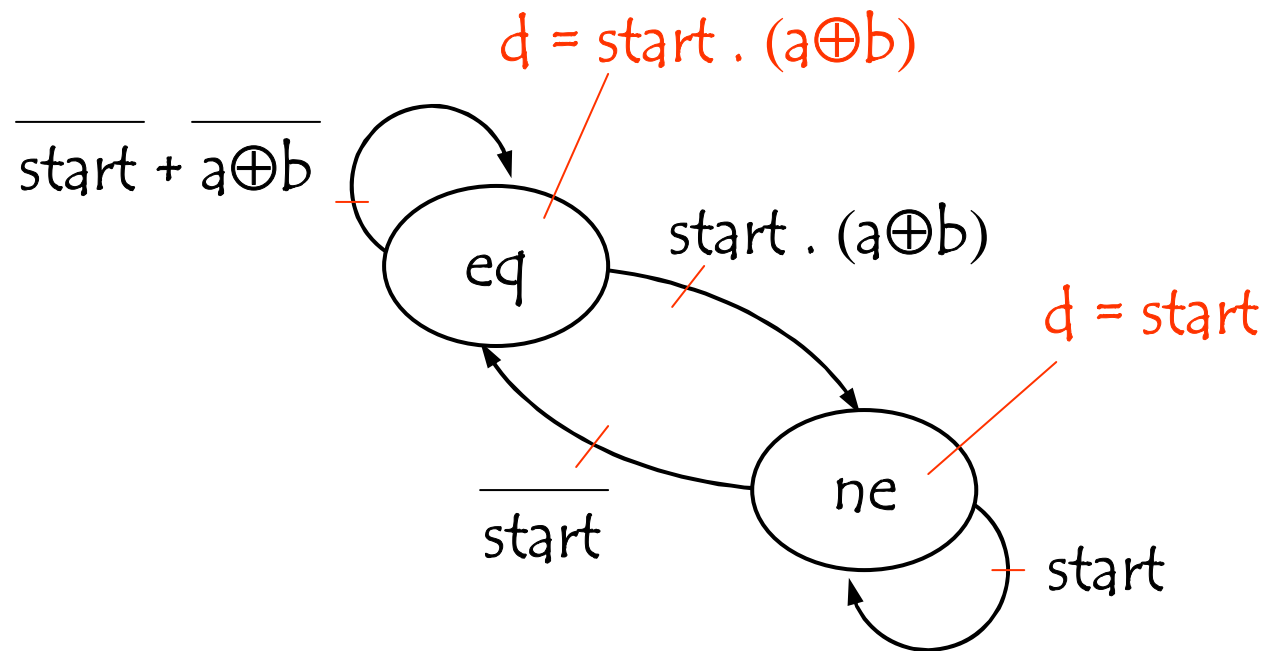

2 states \longrightarrow 1 memory element

CMOS Circuits

Representation of a sequential circuit ?

- State graph

$$\mathbf{G} = (X, Y, S, T, O)$$

define the number of memory elements required to represent $S : M$

represent each state s by a vector of M



CMOS Circuits

Example

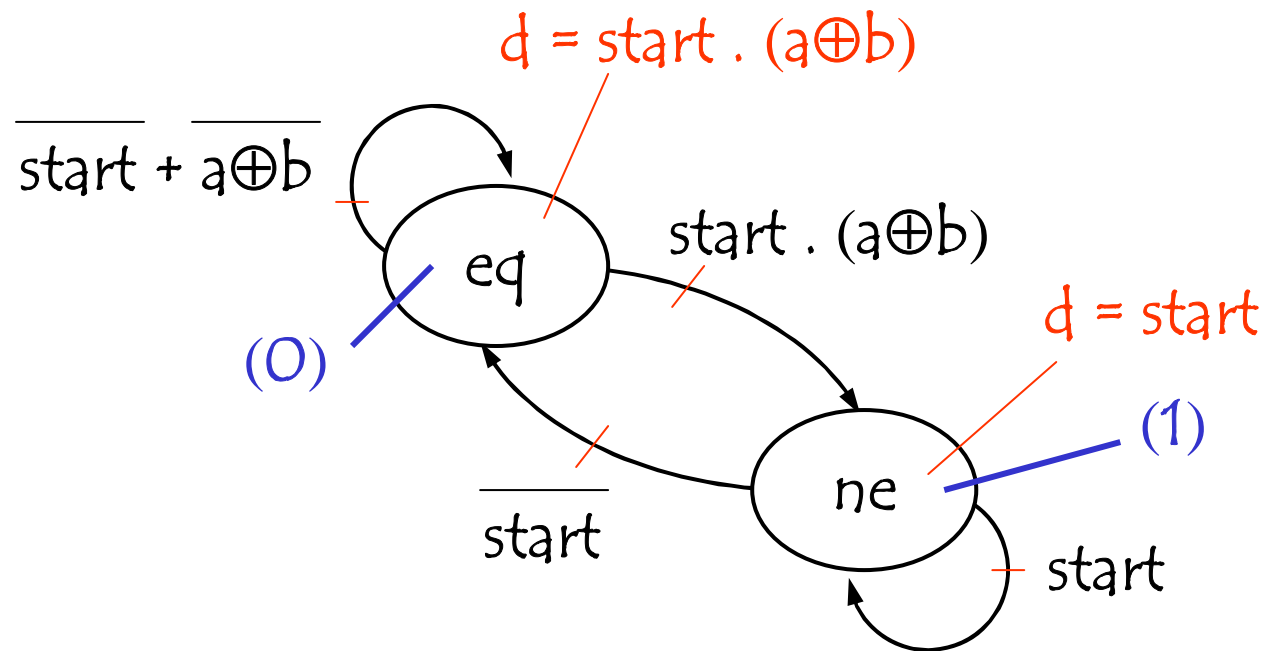

2 states \longrightarrow 1 memory element

CMOS Circuits

Representation of a sequential circuit ?

- State graph

$$\mathbf{G} = (X, Y, S, T,$$

define the ^Otransition function : m_k

m_k = sum of the Boolean function of the transitions that have as target a state where $m_k=1$



CMOS Circuits

Example

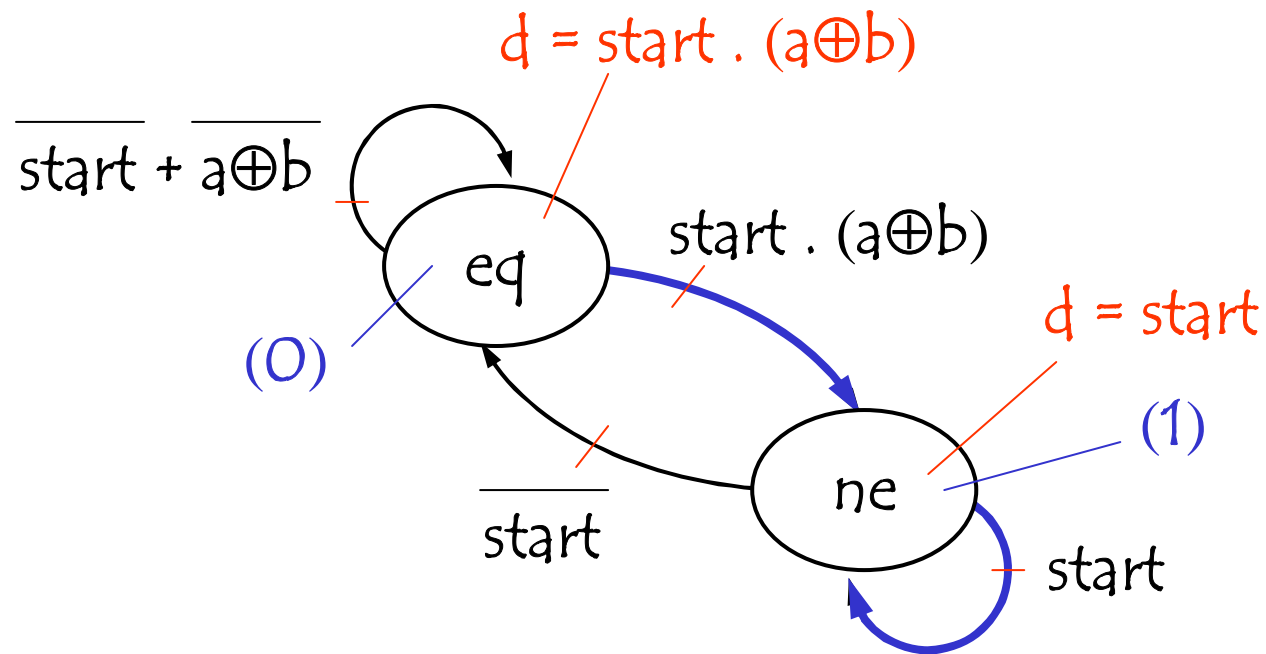

$$m_1 = \overline{m_1} \cdot \text{start} \cdot (a \oplus b) + m_1 \cdot \text{start}$$

CMOS Circuits

Representation of a sequential circuit ?

- State graph

$$\mathbf{G} = (X, Y, S, T,$$

define the ^Ooutput function : y_i

$y_i =$ sum of the output conditions concerning y_i



CMOS Circuits

Example

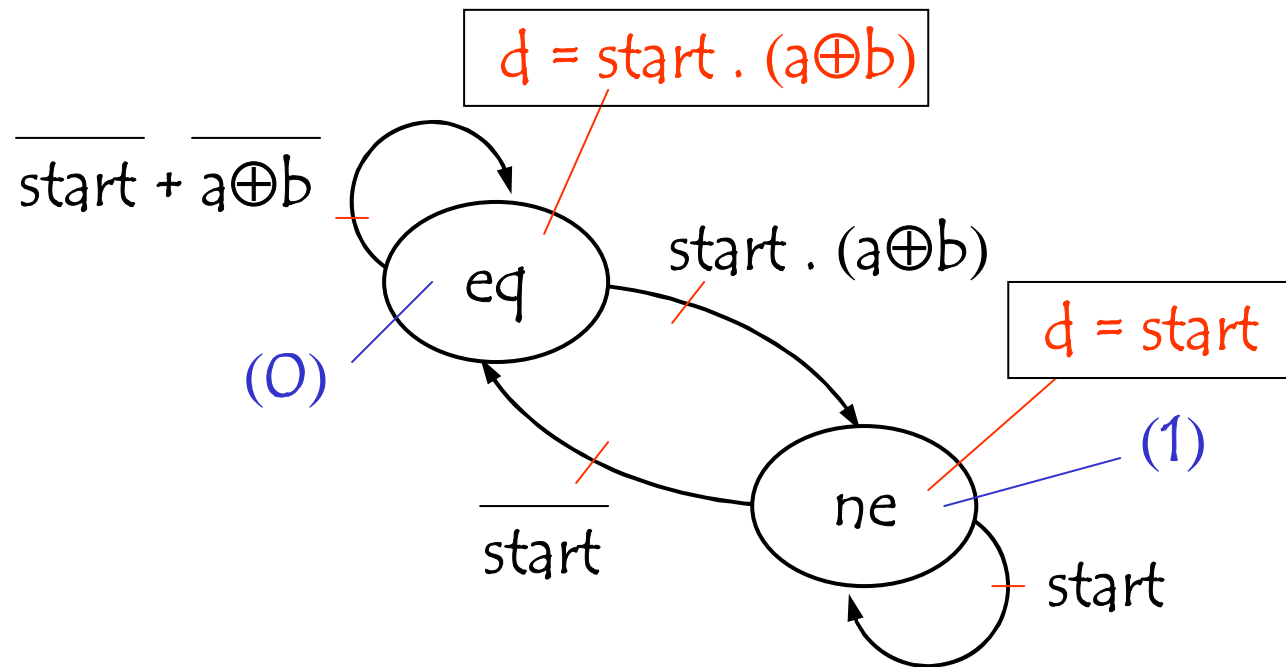

$$d = \overline{m_1} \cdot \text{start} \cdot (a \oplus b) + m_1 \cdot \text{start}$$

CMOS Circuits

Representation of a sequential circuit ?

- State graph

$\mathbf{G} = (X, Y, S, T,$
implement^o the Boolean functions : m_k, y_j

CMOS Circuits

Example

$$m_1 = \overline{m_1} \cdot \text{start} \cdot (a \oplus b) + m_1 \cdot \text{start}$$

$$d = \overline{m_1} \cdot \text{start} \cdot (a \oplus b) + m_1 \cdot \text{start}$$

$$m_1 = \text{start} \cdot (a \oplus b) + \text{start} \cdot m_1$$

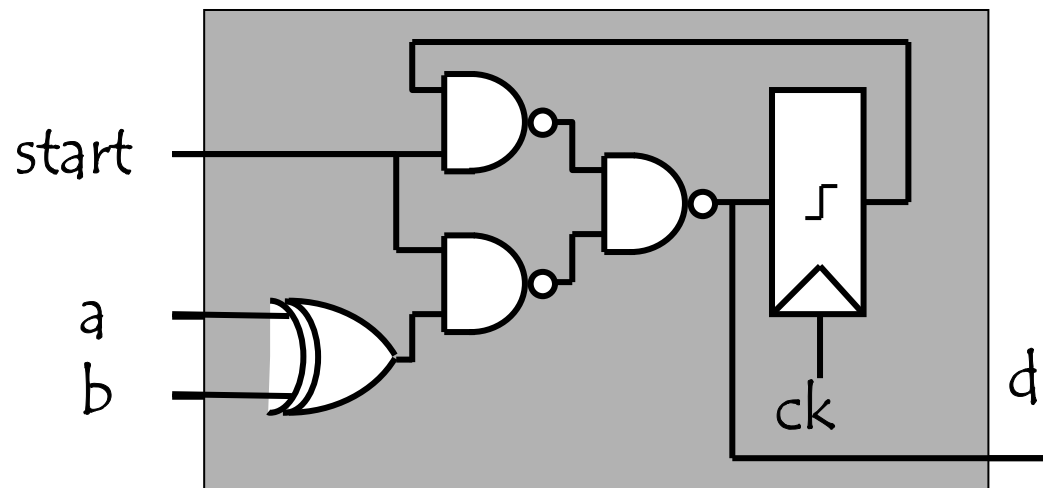

CMOS Circuits

How can I design a sequential circuit (summary) ?

○ **G** = (X, Y, S, T,

○)



graphic representation the behavior



define the number of memory elements
required to represent $S : M$



represent each state by a vector of M



define the *transition function*



define the *output function*



implement the Boolean functions

