Time and Time Transfer

© Dr. Demetrios Matsakis

Legal Note

These viewgraphs are intended to cover technical aspects of the timekeeping art, but to specifically exclude legalities and/or government policy. If by accident any public timekeeping policy is alluded to, such allusions should be considered the personal opinions of Dr. Matsakis and not a representation of current or future policies of the U.S. Naval Observatory, Department of Defense, or U.S. government.

Course Outline

A. What is Time?

B. Pictorial Representation of Timekeeping Math

- Characterizing Clocks
 - Noise types
 - Stability measures
- Generation of timescales, including UTC
- Steering Clocks

C. Time Transfer

- Telephones, modems
- Internet: NTP
- GPS
- Two Way Satellite Time Transfer

D. Timing in the Future

Appendix 1: Parade of Clocks

Appendix 2: Philosophy of Time, including Relativity

Appendix 3: Statistical Details

Appendix 4: Timescale Details

Appendix 5: Control Theory

Appendix 6: Time Transfer Details

What Is Time?

According to Webster's New Collegiate Dictionary:

“The measured or measurable period during which an action, process, or condition exists”

According to Demetrios Matsakis:

“That coordinate which can be most simply related to the evolution of closed systems”

Time as Defined by Measurement

“The second is the duration of 9,192,631,770 periods of radiation corresponding to the transition between the two hyperfine levels of the ground state of the undisturbed cesium-133 atom” Time is the phase of this radiation.

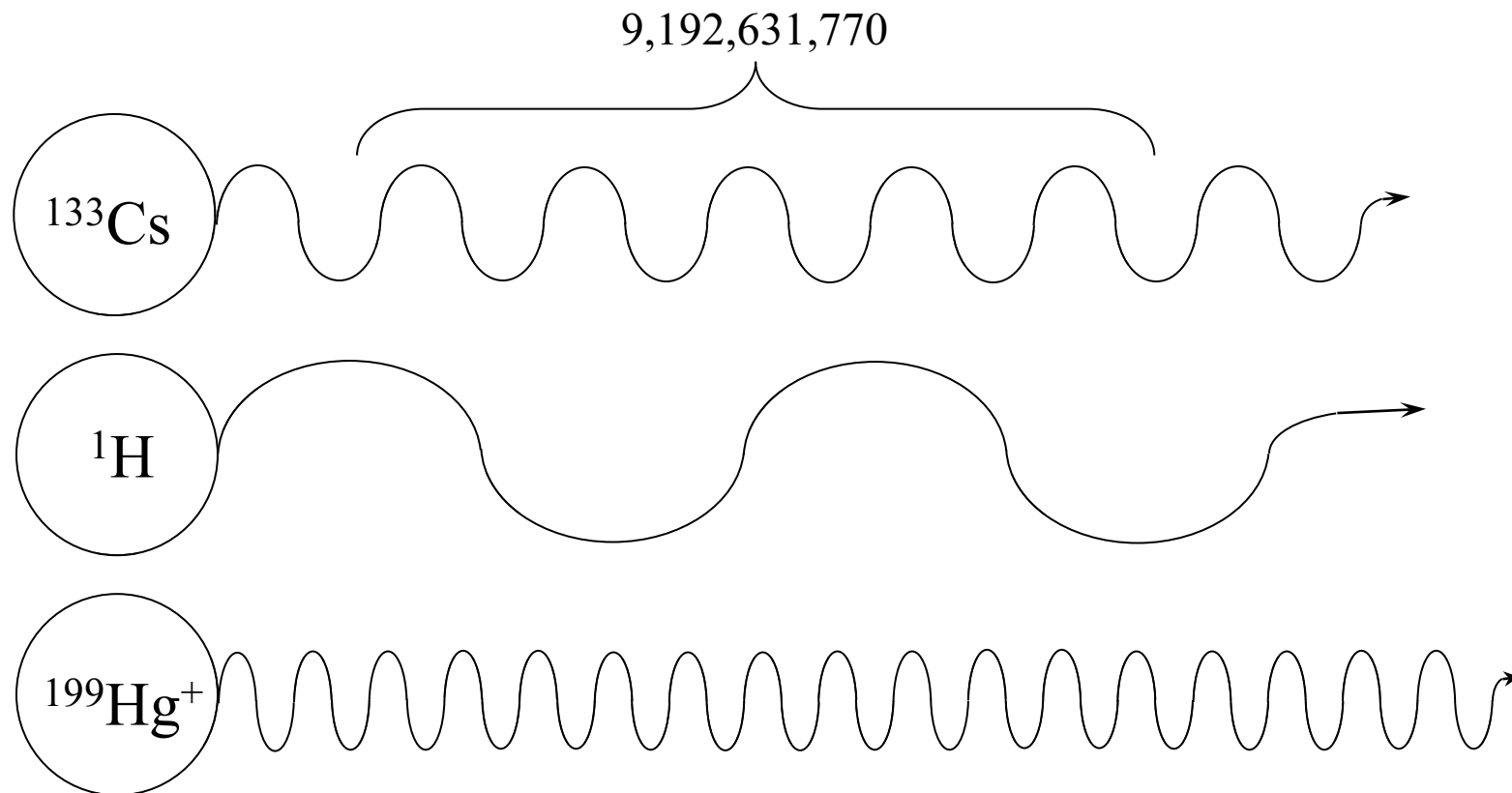

**Why not just use the Earth's
rotation?**

Length of Day (LOD) 1620-2006

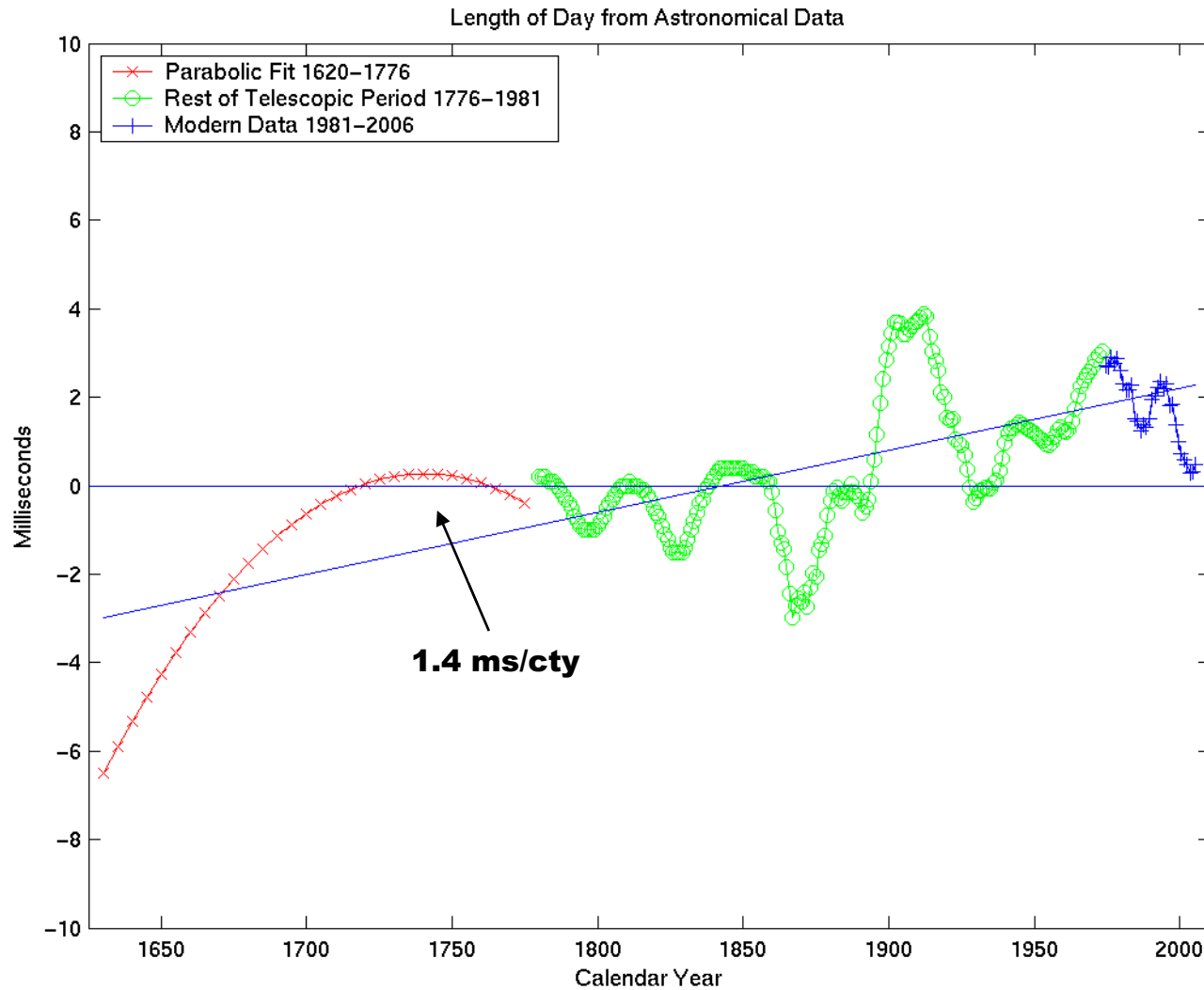

Sources: F.R. Stephenson and L.V. Morrison, *Phil. Trans. R. Soc. London* **A313**, 47 – 70 (1984),
<http://maia.usno.navy.mil>, and <ftp://maia.usno.navy.mil/ser7/finals.all>

Schematic Illustration Of The Forces That Perturb The Earth's Rotation

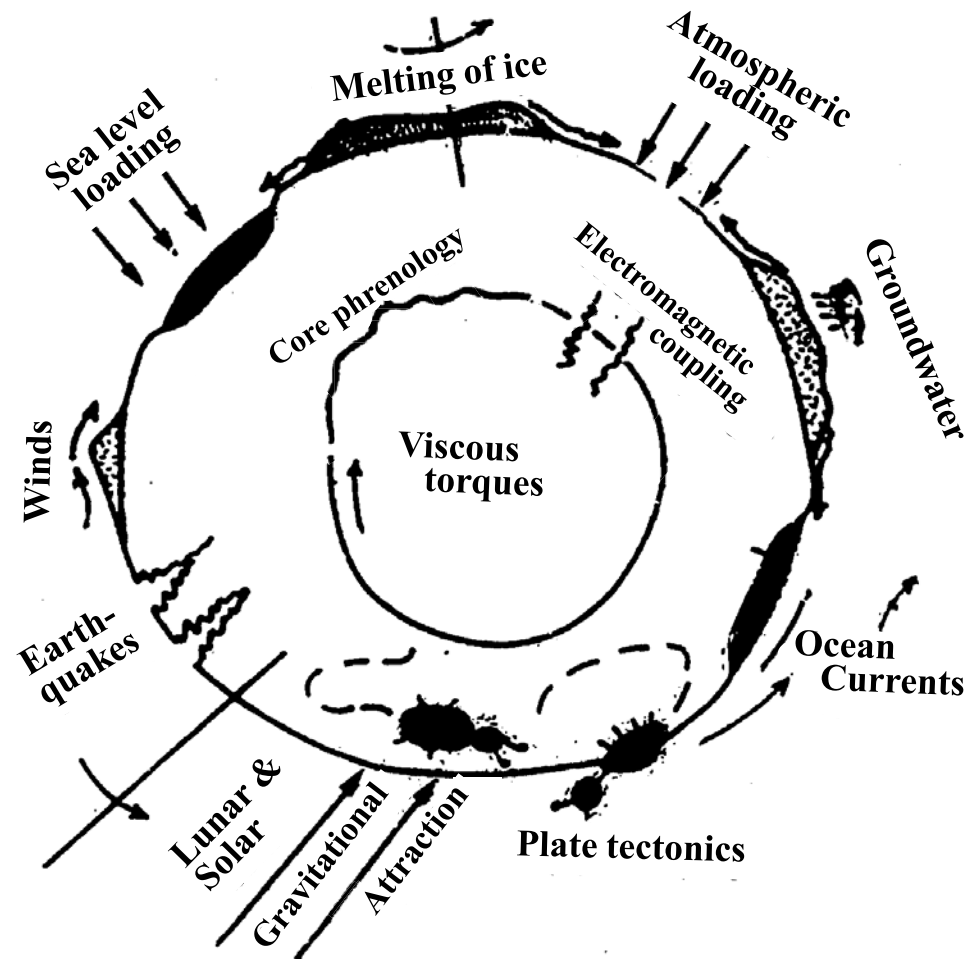

Source: Thomas Gold, *Nature*

Polar Motion (1984-2002)

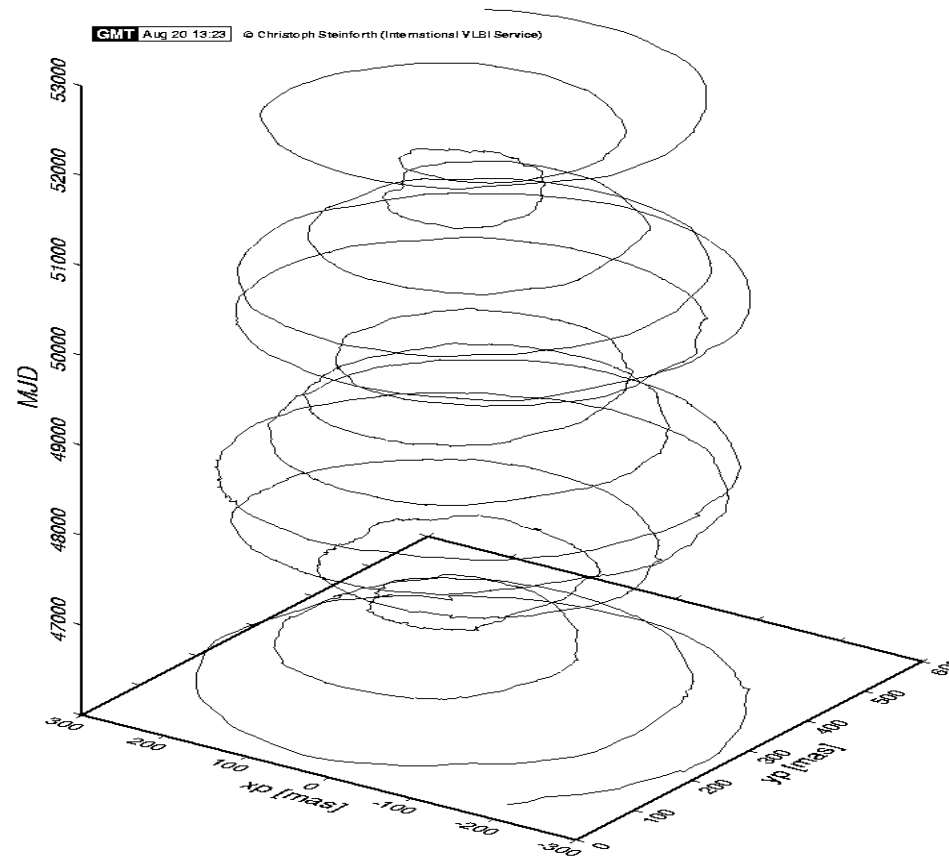

Source: <http://giub.geod.uni-bonn.de/vlbi/IVS-AC/combi-all/start.html>

Variations in Length of Day

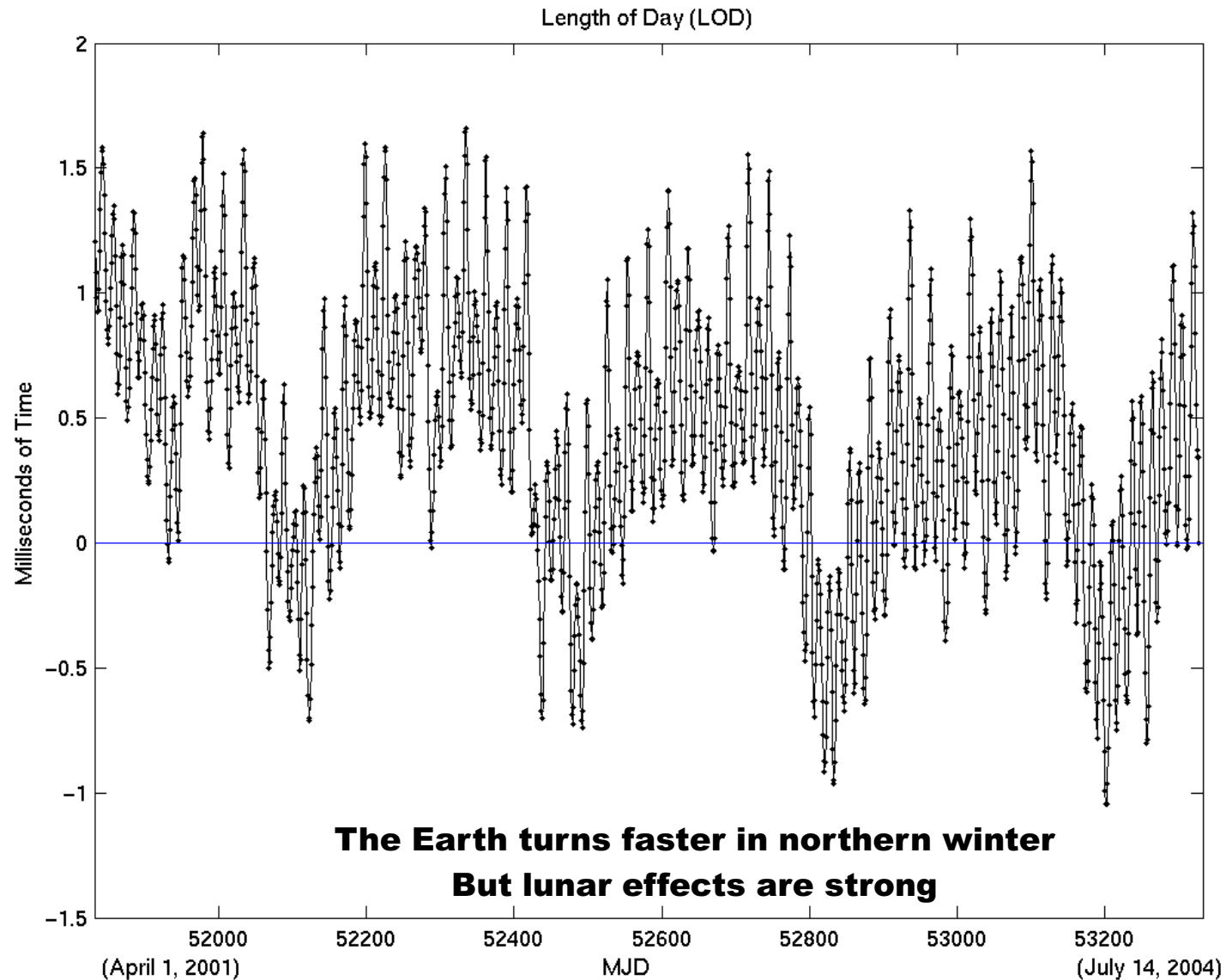

Modern Life has LONGER days

- Tides are oceans following moon
 - “Crashing” into coastline and seafloor
- Tides slow down the rotating Earth
 - Days get longer, 1 day approaches 1 month
 - Moon’s orbit gets further away
 - Sun and other bodies also have effects
- Earth has lost 14 hours since 1815 BC
 - From Chinese solar-eclipse records
- ~100 million years ago, day lasted only 20 hours
 - From fossilized nematodes

Even the cheapest atomic clock is more precise than the Earth

Rb Vapor Cell Principles

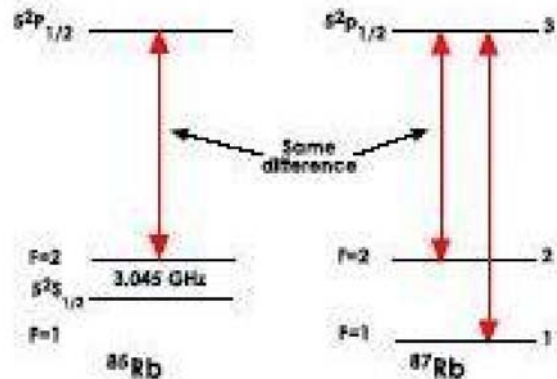
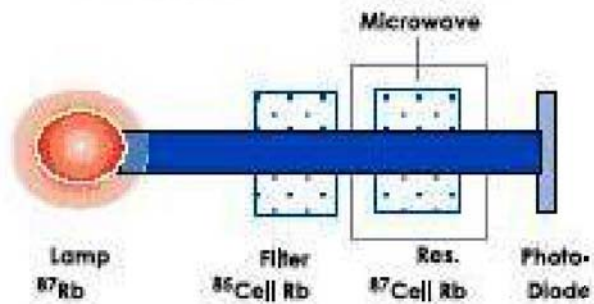

1. Light from ⁸⁷Rb lamp contains both 3-1 and 2-1 lines.
2. ⁸⁵Rb Cell filters out the 2-1 line and transmits the 3-1 line.

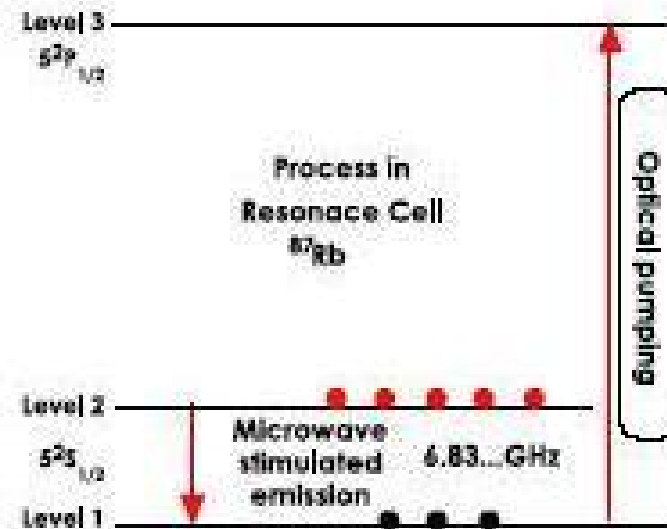

3. The filtered light "optically pumps" the ⁸⁷Rb atoms in the resonance cell from level 1 to 3.
4. A Microwave signal at a frequency of 6.84 GHz is injected into the cell and induces transition from level 2 to 1.
5. When the injected wave frequency matches the difference of the 2-1 line, the photo-diode detects a reduction in the intensity of the transmitted light.

Source: www.accubeat.com

Cesium Standard

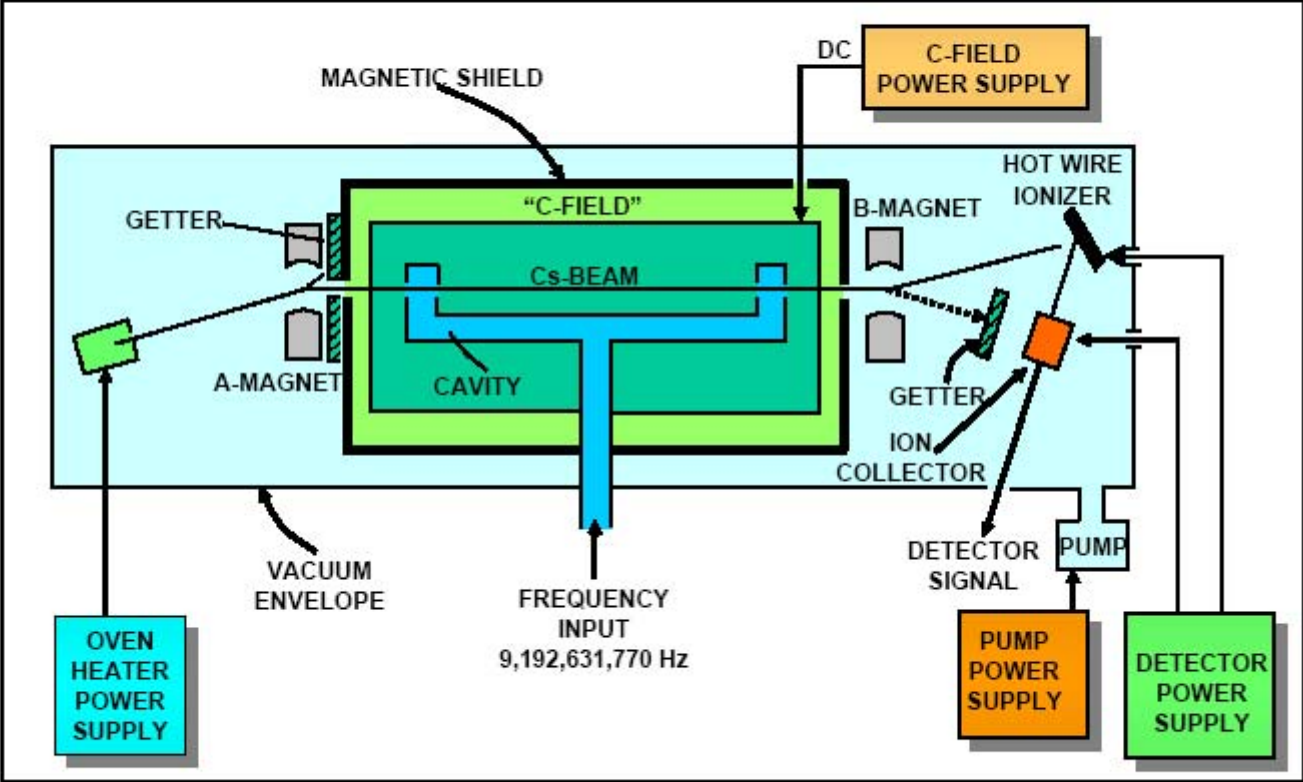

Source: John Vig

Hydrogen Maser Frequency Standard

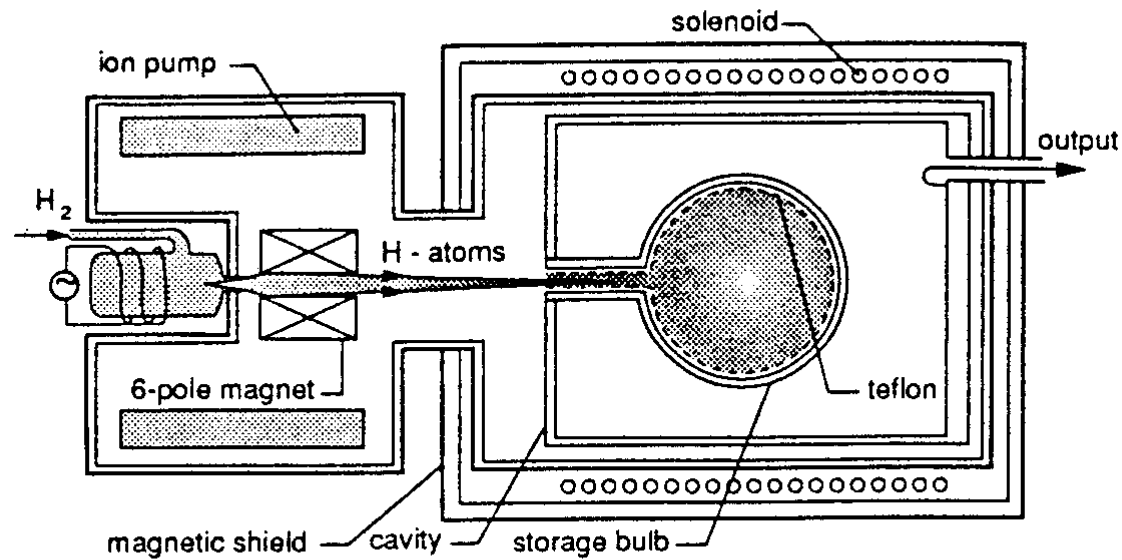

Figure 11.2 The basic elements of a hydrogen maser

Time & Frequency Units

TIME				FREQUENCY $f=(t_b-t_a)/\Delta T$	
Second	1.0 s	s	10^0 s	1 s/day	$1.16 \cdot 10^{-5}$
Millisecond	.001 s	ms	10^{-3} s	1 ms/day	$1.16 \cdot 10^{-8}$
Microsecond	.000001 s	us	10^{-6} s	1 us/day	$1.16 \cdot 10^{-11}$
Nanosecond	.000000001 s	ns	10^{-9} s	1 ns/day	$1.16 \cdot 10^{-14}$
Picosecond	.000000000001 s	ps	10^{-12} s	1 ps/day	$1.16 \cdot 10^{-17}$
Femtosecond	.000000000000001s	fs	10^{-15} s	1 fs/day	$1.16 \cdot 10^{-20}$

Modified Julian Day (MJD)

- Julian Day = JD = days since 4713 BC
 - Invented by Joseph Scalinger, circa 1600
 - JD increments at noon
 - Better for astronomers who observe at night
- Modified Julian Day = MJD = $JD - 2400000.5$
 - Days since 1858.8, November 18, 1858
 - Increments at midnight
 - Better for most people

Precision vs. Accuracy

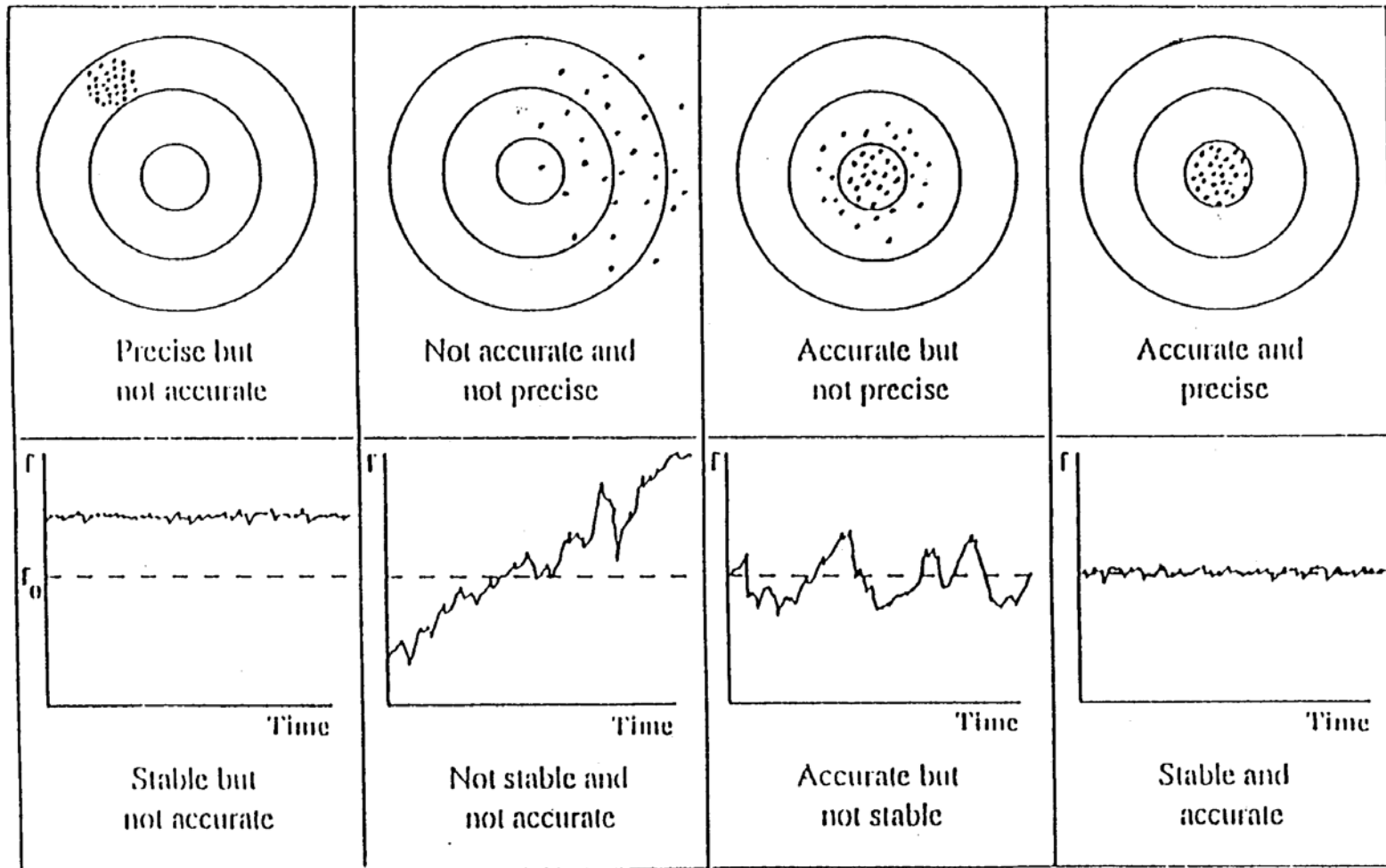

Source: John Vig's Tutorial

Three Complementary Ways To Characterize Clock Time Series

I. Inspection

II. Fourier Transform

III. Variances of Differences:

AVAR, TVAR, MVAR,

HADAMARD, TOTDEV, etc.

Illustrative Clock Data

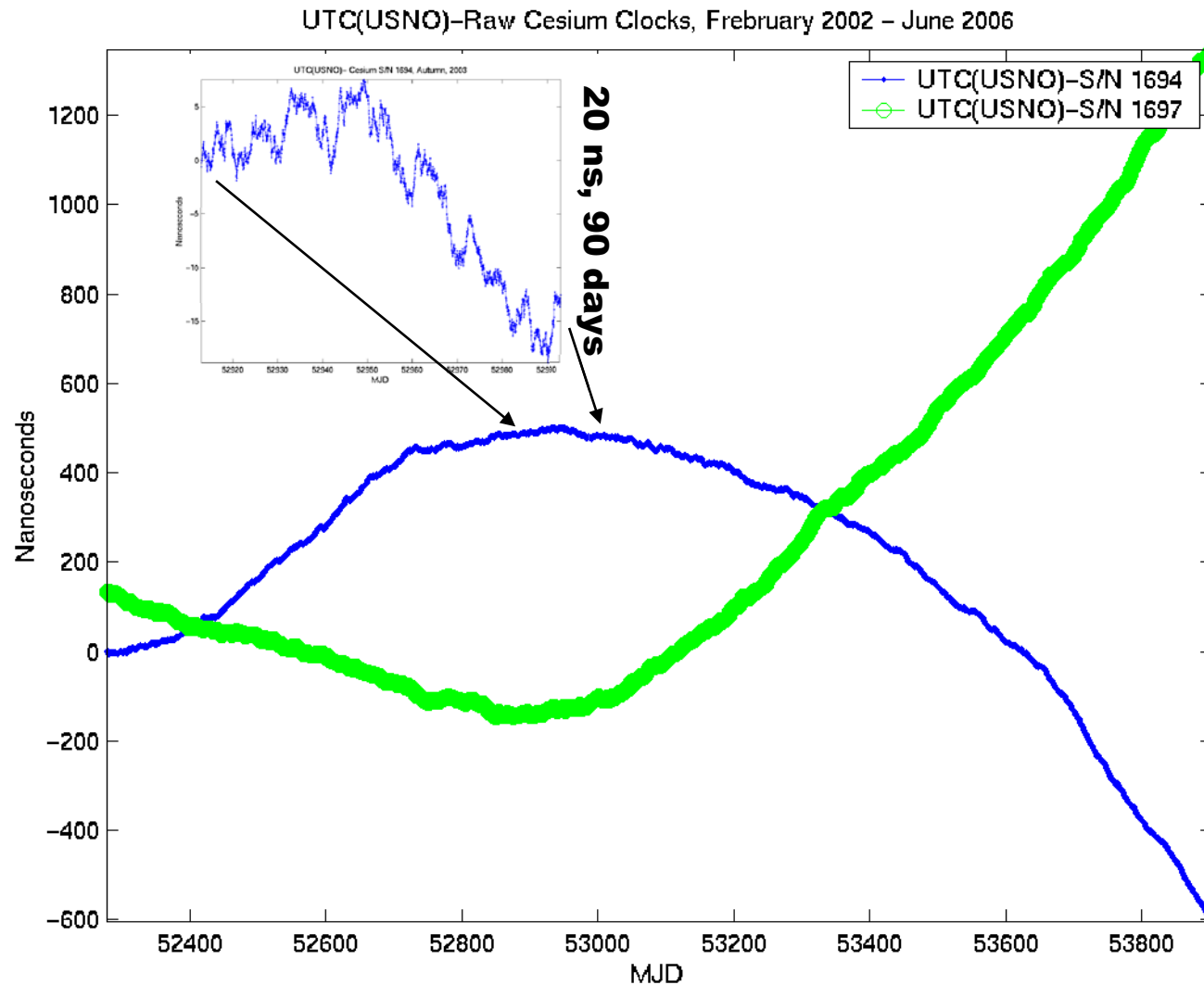

Five Fundamental Noise Types

Combined, they can model clock noise

Source: Dave Allan

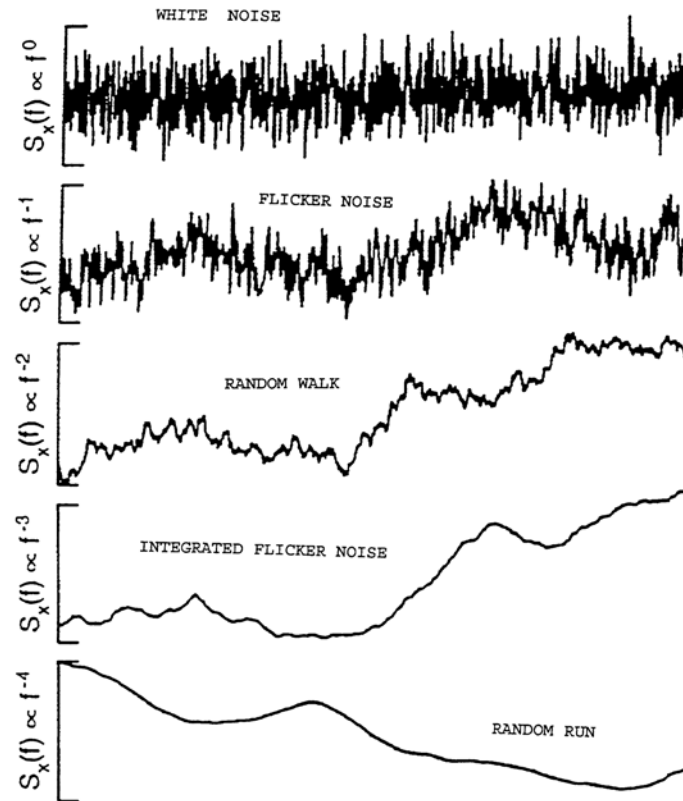

Noise in clock phase (time) also termed phase modulation (PM)
Noise in clock frequency also termed frequency modulation (FM)



**“With five parameters
I can fit an elephant.”
- Enrico Fermi**

Fourier Transform of Noise Models

Power Spectral Density is square of plotted amplitude
(technique works better for periodic variations)

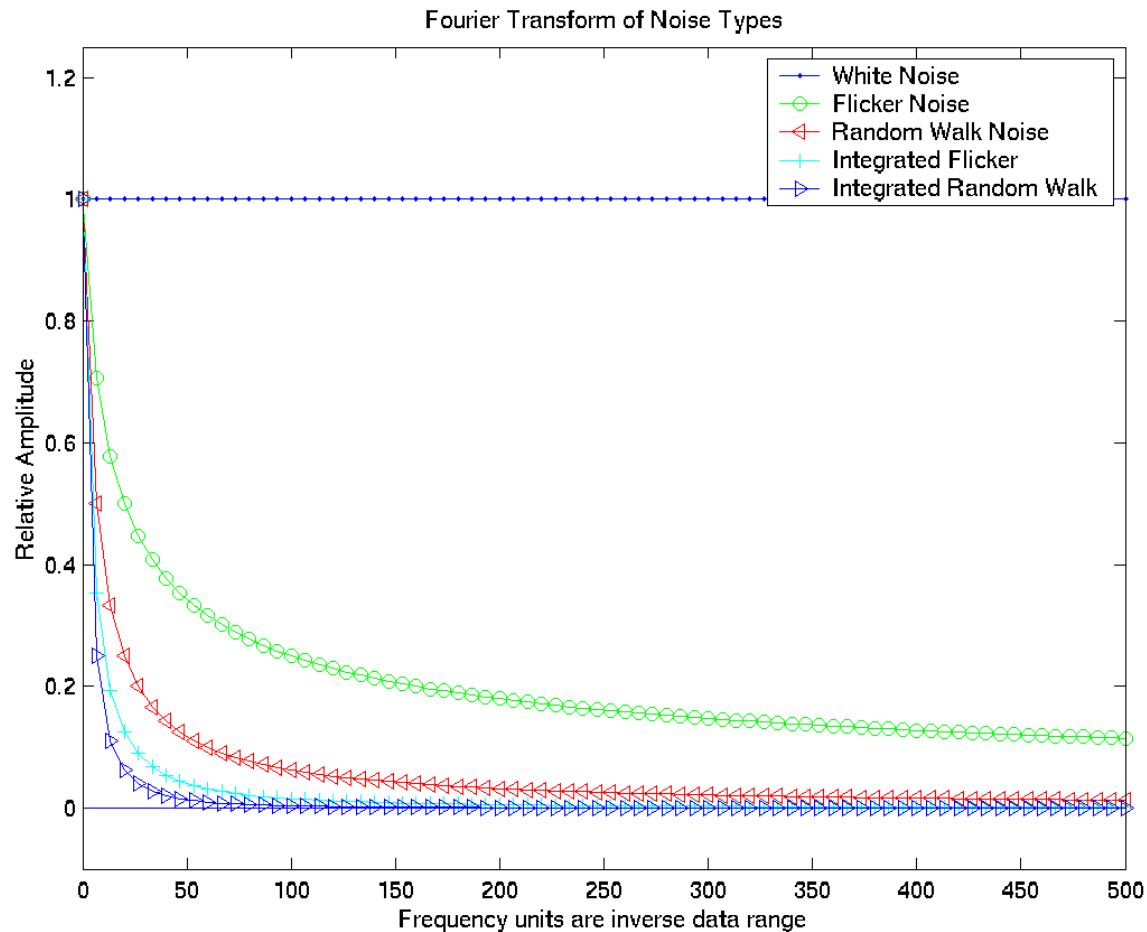

How to Quantitatively Measure a Clock's Time/Frequency Accuracy/Precision?

It could be measured by the data's Root Mean Square (RMS), which is also the square root of the variance (VAR).

Unfortunately, if a clock changes frequency systematically over its life, its time and frequency RMS and VAR are unbounded.

Every clock we know of does this.

Rephrase The Question

How much does the frequency vary from one interval, of duration τ , to the next interval?

- That's the Allan Deviation (ADEV)
- ADEV=square root of the Allan Variance (AVAR)
- ADEV is also written $\sigma_y(\tau)$
- AVAR is also written $\sigma_y^2(\tau)$

Example: Clock Whose Frequency Increases

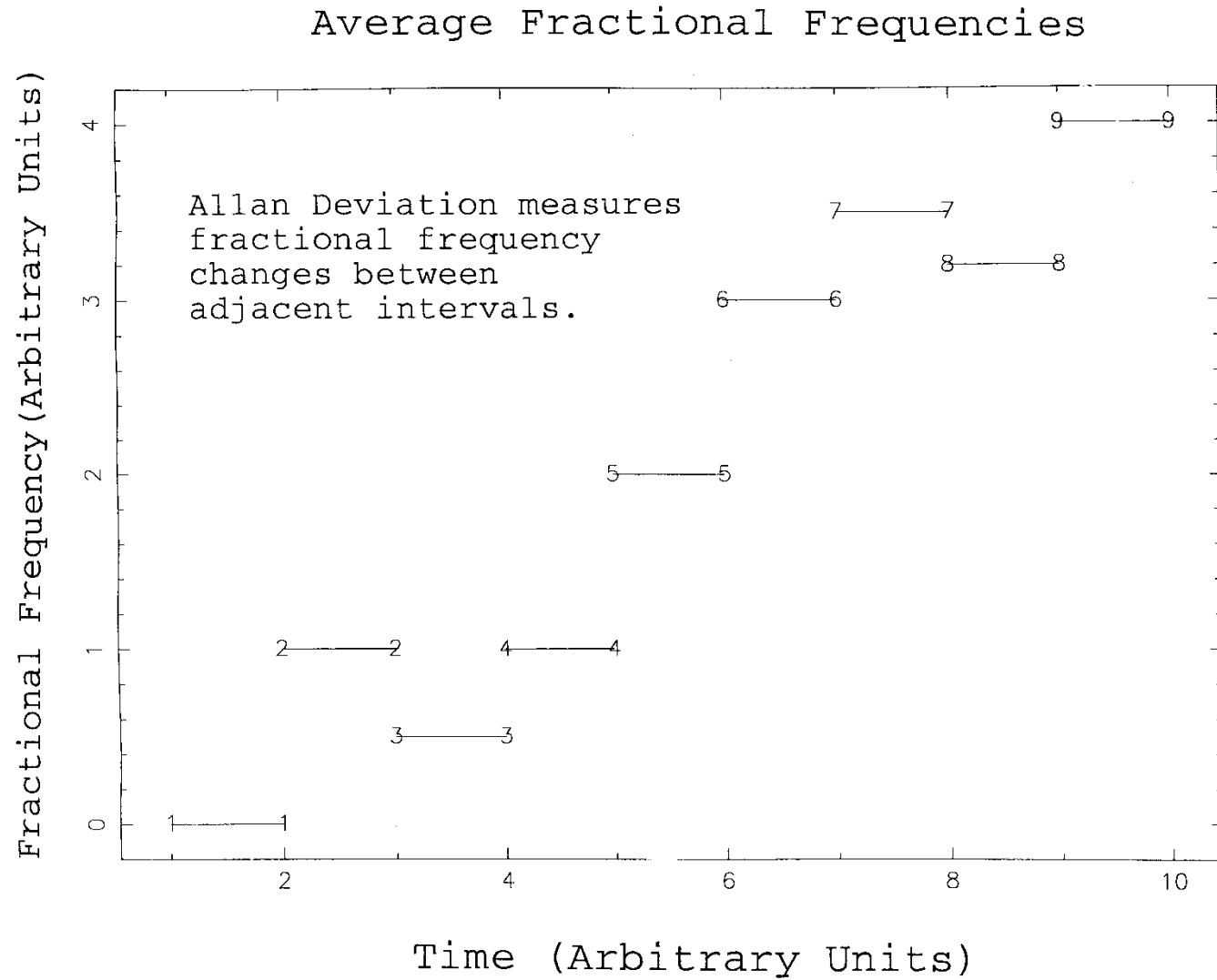

Example: Averaging Adjacent Frequency Bins

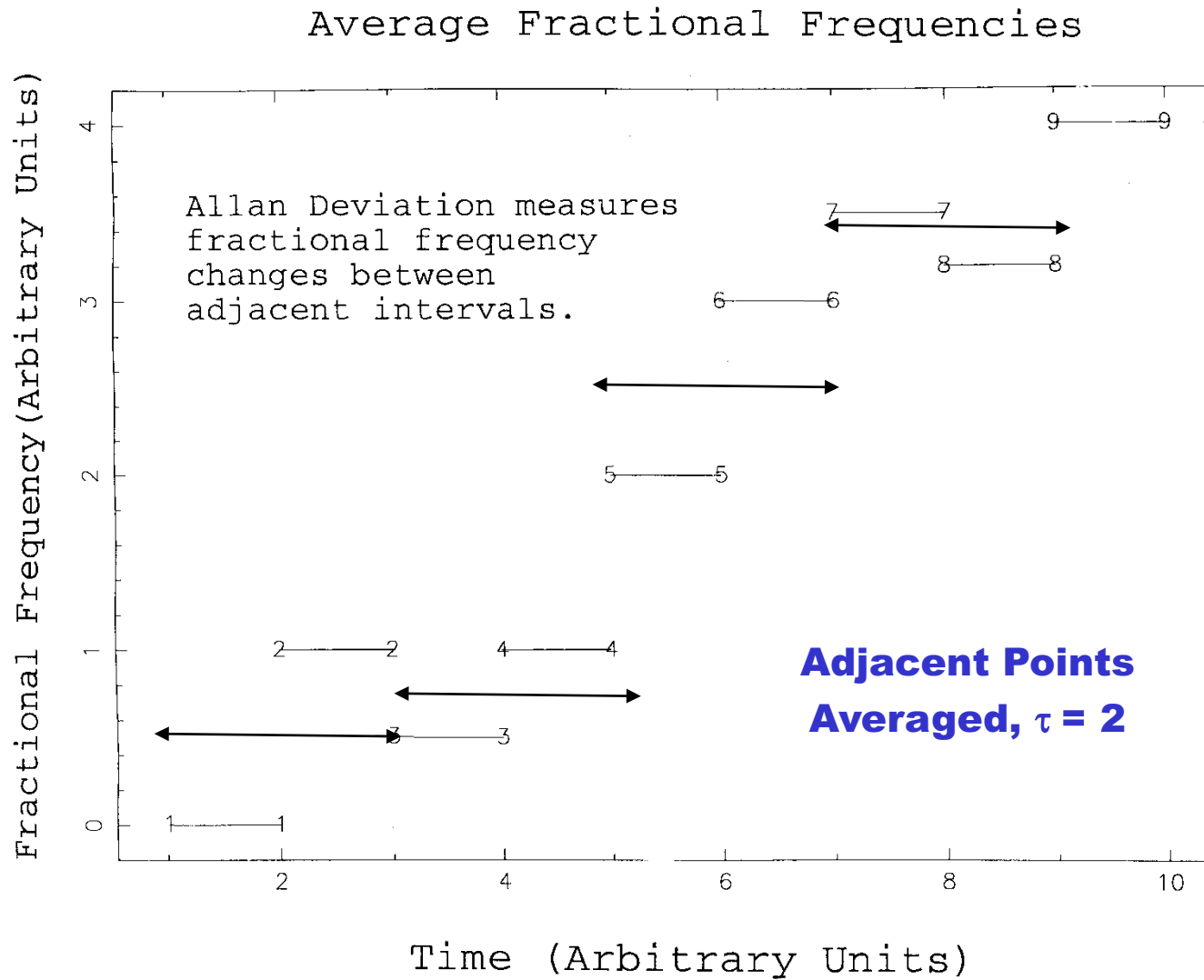

**How does the Allan Deviation
(ADEV, or $\sigma_y(\tau)$), depend upon
the kind of noise in the time series?**

Allan Deviation of Random Walk and Random Run

Clock Phase (=time)

Clock Freq.

Allan Deviation

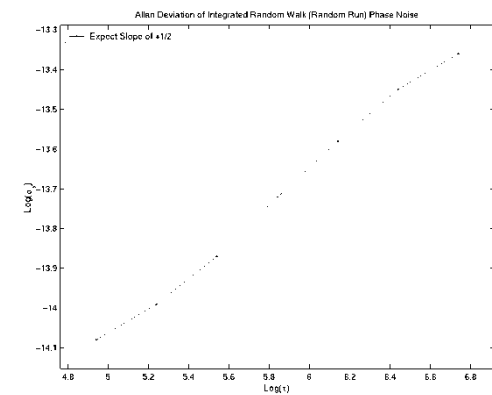
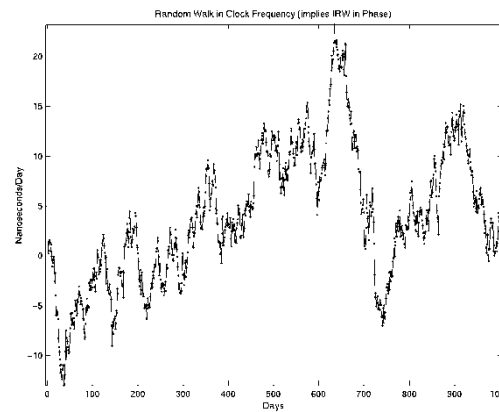
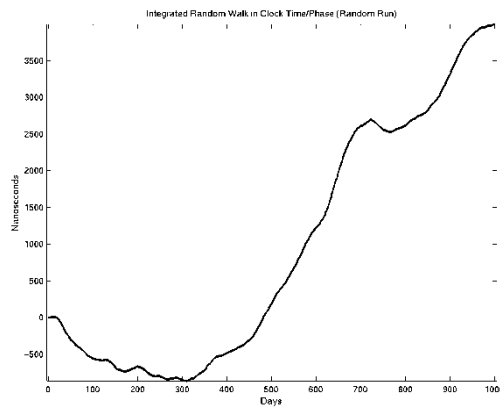
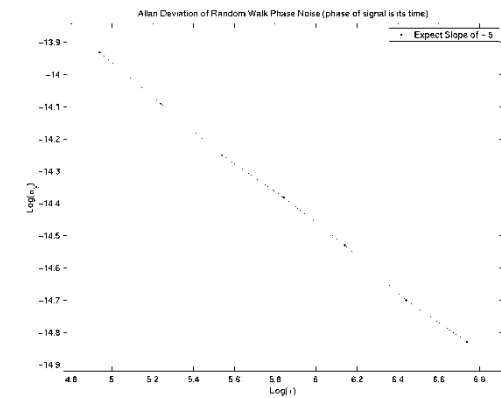
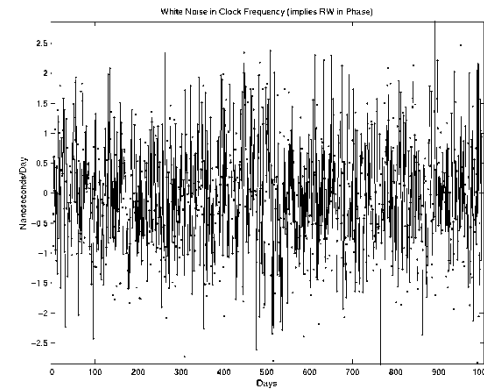
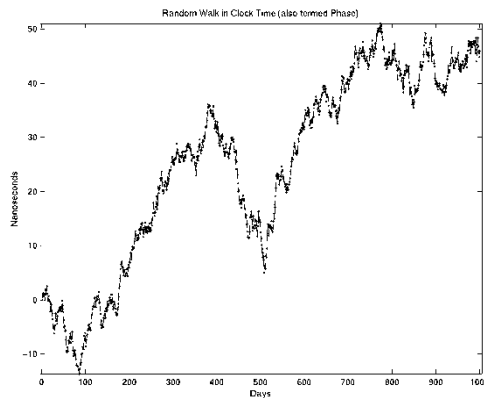

Typical Maser Sigma-Tau Pattern

White Noise dominates over shortest averaging times
Random Walk FM=Random Run PM over longest averaging times

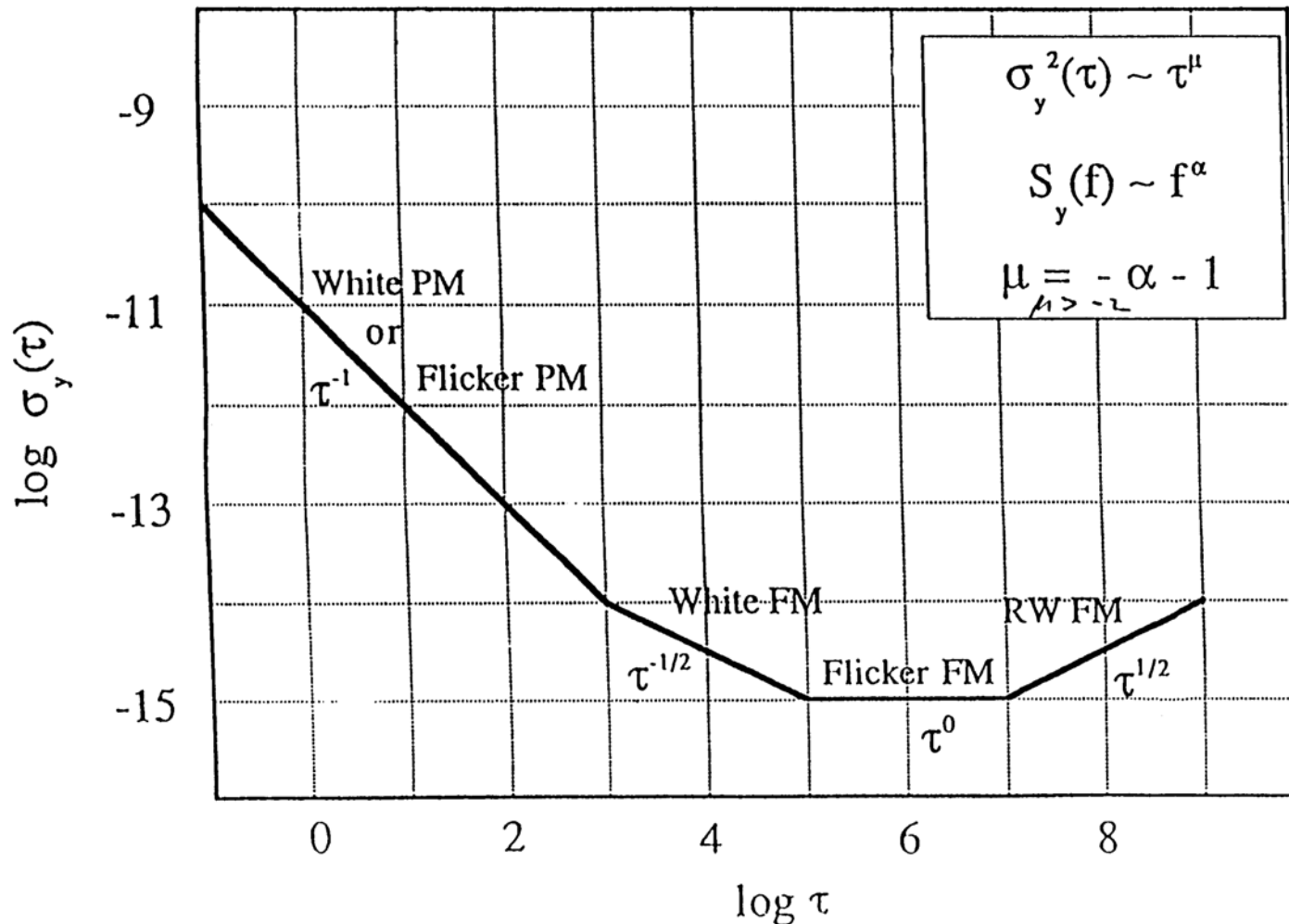

Problem

Allan Deviation can't distinguish between white phase noise and flicker phase noise.

NO PROBLEM

Use Modified Allan Deviation (MDEV)

How MDEV is Defined

Like ADEV, except replace each freq by an average of frequencies of nearby points

If you multiply MDEV by $\tau/\sqrt{3}$, you get the

Time Deviation, TDEV. TVAR is the square of TDEV.

**How does the Time Deviation (TDEV),
depend upon the kind of noise in the data?**

Example: TDEV of White Phase and Random Walk Noise Models

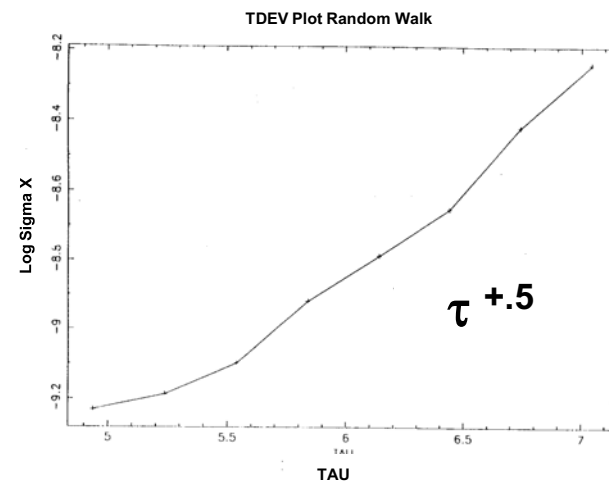
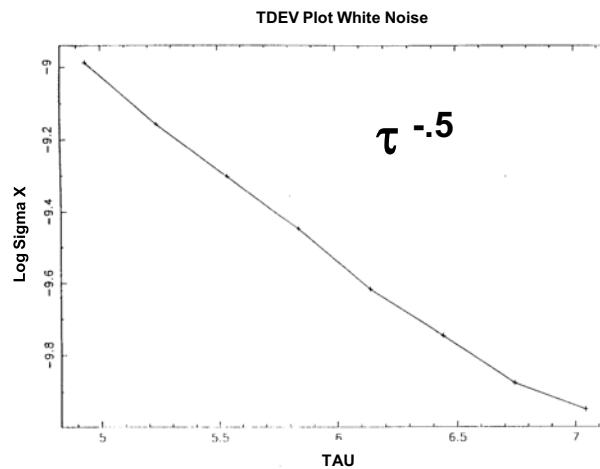
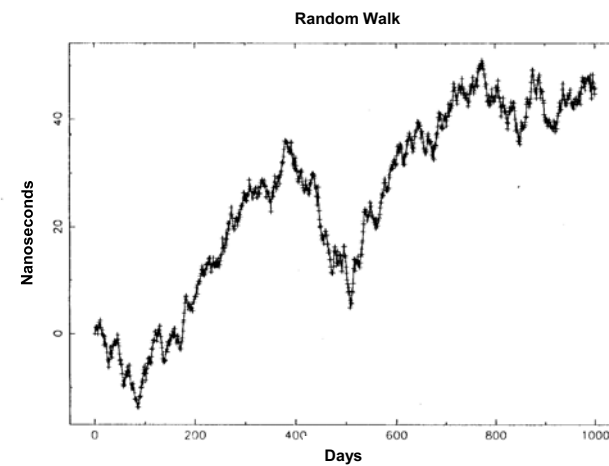
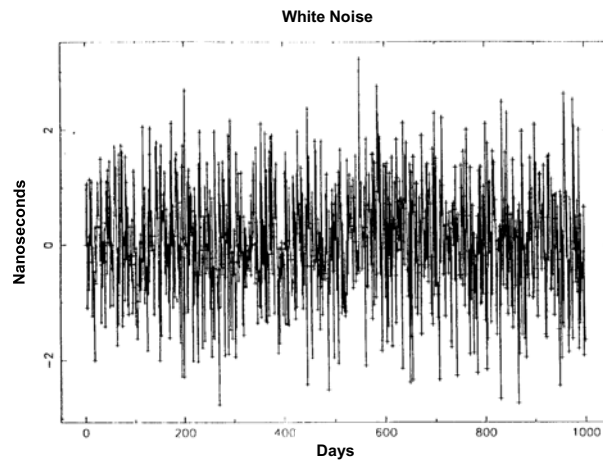

TDEV distinguishes White PM from other noise types

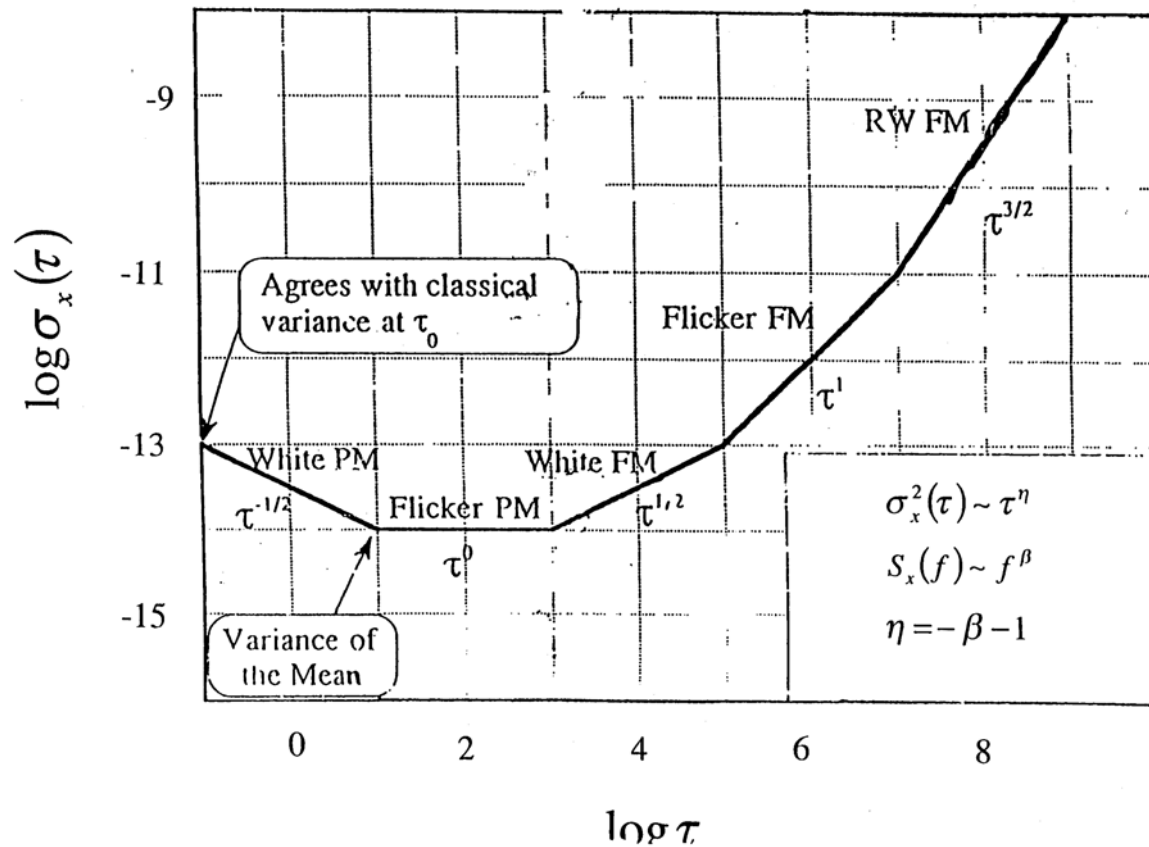

TDEV= Time Deviation

One of Many Statistical Pitfalls

All of the discussed measures are insensitive to overall Phase/time slopes, so there is no harm in removing or adding such slopes to data. In fact, you usually should remove slopes to avoid binning quantization problems.

BUT... If you detrend data with a higher-order fit, you will artificially force the statistic towards 0 for large tau. You should *never* remove a second-order term to compute an Allan deviation.

Stability of Various Frequency Standards

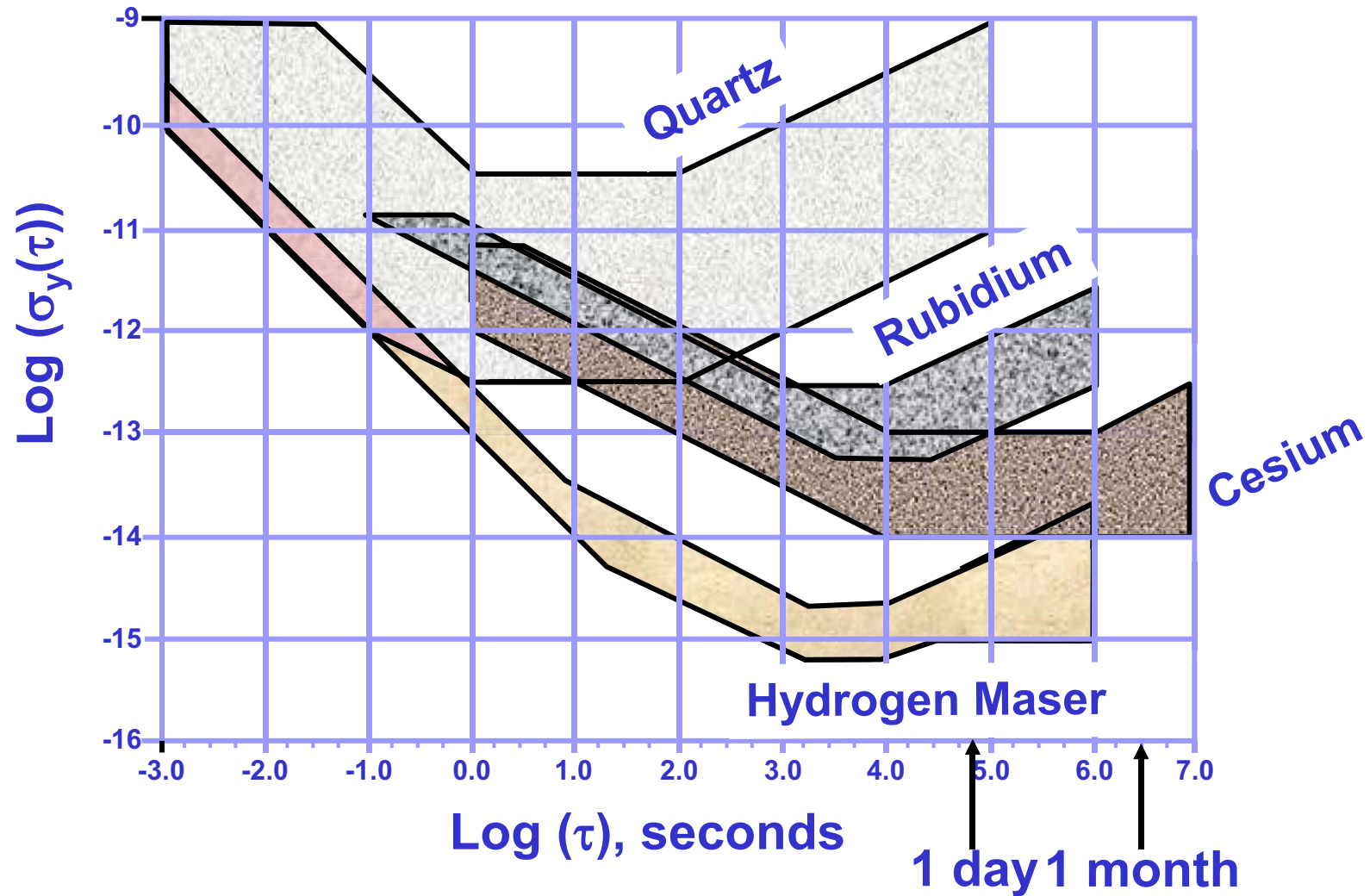

Source: http://www.ieee_uffc.org/fc (John Vig and R. Sydnor) 34

What is a Timescale?

- A useful average of clocks
 - Usually a weighted average of observed minus predicted data.
 - Timescales must not jump
- Goal is to measure time better than any individual clock
 - Can't optimize everything at the same time
 - Should be optimized for goals of interest
 - Measure “absolute time” of a clock ensemble?
 - Produce a constant frequency?
 - How much do you care what that constant is?
 - Track a reference clock or timescale (steering)?
 - Trade precision for robustness?
 - Save money on computers and mathematicians?

Continuity Constraint

- Timescale must not jump
- A clock model helps when
 - Clocks are added
 - Clocks are removed
 - Clock weights are changed
 - A clock misbehaves
 - By making identification easy
- Some prediction algorithms in use today (details in appendix):
 - Polynomial
 - BIPM (Algos), USNO (Percival Algorithm)
 - Exponential Filter
 - NIST, NICT
 - Adaptive ARIMA (Auto-Regressive Integrated Moving Average)
 - INPL
 - Kalman Filter
 - GPS Composite Clock, IGS

In Modeling, Try To Work with White Noise

- Quantities are well-defined
- Most theorems apply only to white noise
- If the noise or parameter variation isn't white, whiten it if possible:
 - A. Add another parameter
 - B. Replace data by their Nth order differences
(e.g. convert time to frequency)
 - C. Chose the time-interval where it is white

Continuity from Averaging Frequencies

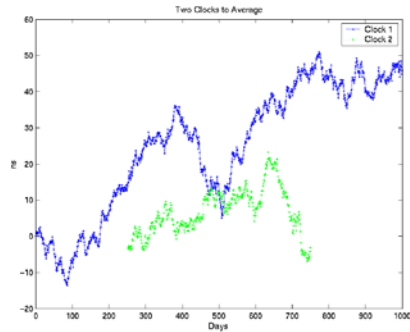

1. Phase data from two clocks (simple average would jump when clock 2 availability changes)

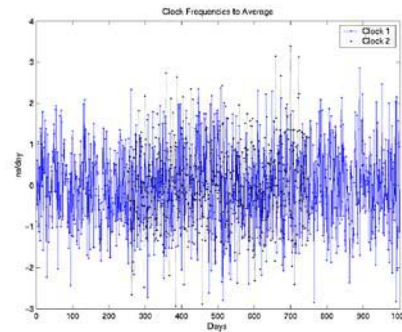

2. Data of the two clocks after conversion to frequency (freq point= difference of 2 time points)

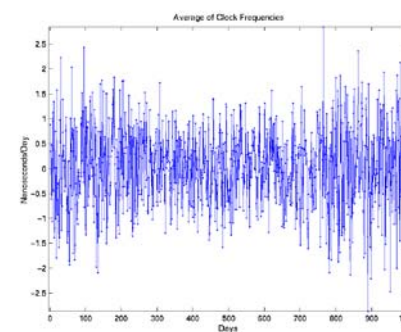

3. Average the frequencies of the two clocks

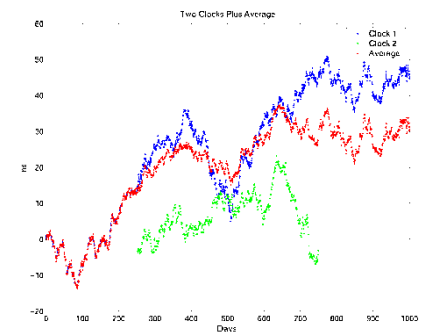

4. Sum frequency average to create time average (Plotted with original phase data of two clocks)

Clock Weights in Timescales

Optimal weighting depends upon

- **Clock Statistics**
 - **If Gaussian, weight by $(1.0 / \text{Variance})$**
- **Stability interval of interest**
 - **Could weight by $1.0 / (\text{Allan Variance})$**
- **Effects if highly weighted clock fails**
 - **If you can determine it is failing**
- **How well above are known**

Timescale Summary

Timescale algorithms can differ in:

1. Continuity constraint
2. Clock prediction method
3. Clock weighting
4. Data editing

Each of these points is a matter of active research.

Coordinated Universal Time (UTC)

- **International Time Standard**
 - **Treaty of the Meter**
- **Computed by International Bureau of Weights and Measures (BIPM)**
 - **BIPM located near Paris France**
 - **Data from ~50 institutions**
 - **Data from > 200 atomic clocks**
- **Computed and distributed by months**
 - **5-day spacing, precise to 0.1 ns**
 - **Emailed 10-15 days after month ends**

Contributors To EAL (UTC) By Weight

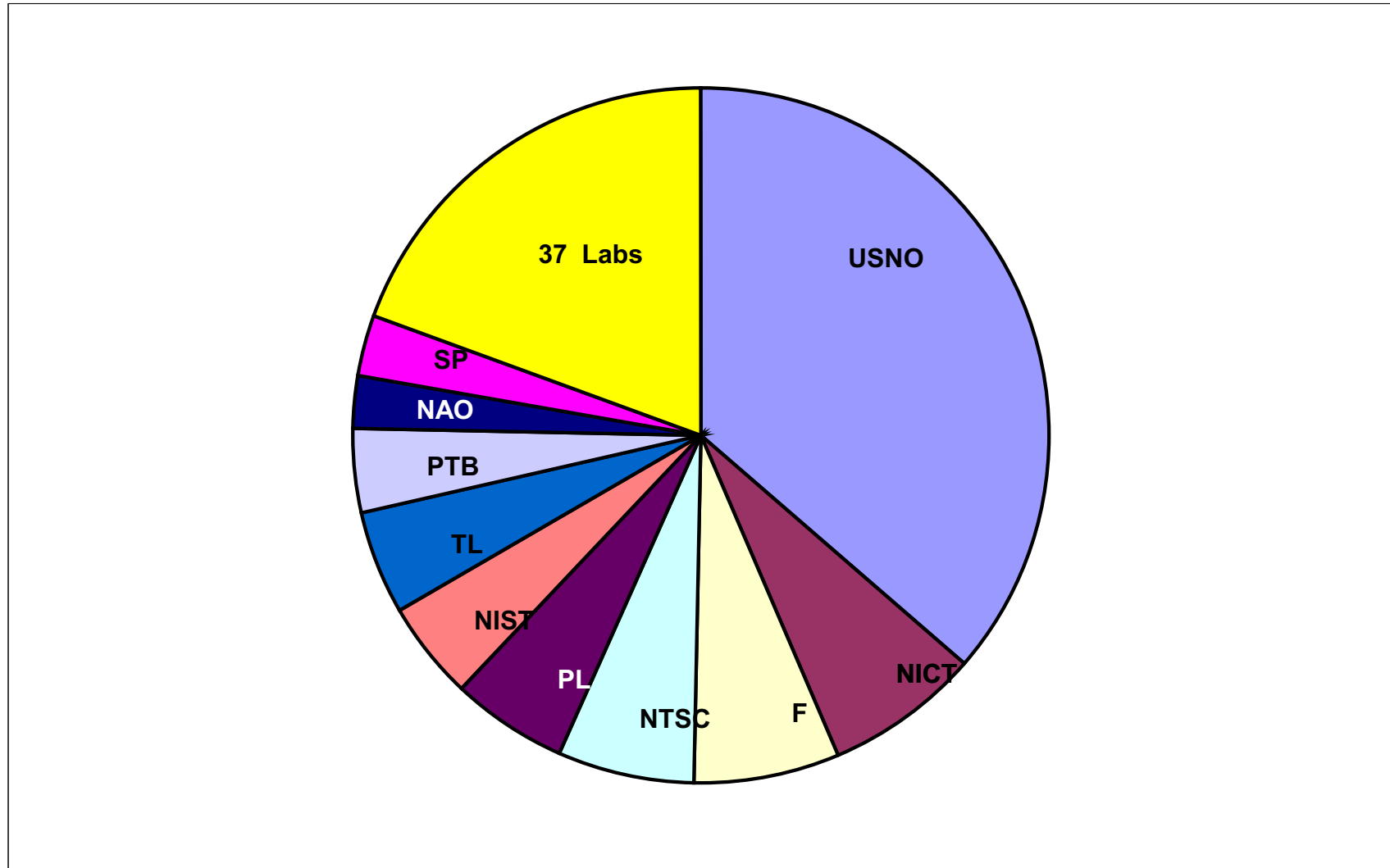

Source: BIPM Circular T, April 2006

How BIPM Computes UTC

- Step 1: Generate EAL
 - EAL=Echelon Atomique Libre
 - French for Free Atomic Time Scale
 - EAL=Average of “secondary standards”
 - Clocks whose calibration is not maintained
- Step 2: Generate TAI
 - TAI=International Atomic Time
 - Adjusts frequency of EAL towards primary standards
 - Primary standards have calibrated frequency
 - Maintained by few institutions
- Step 3: Generate UTC (next viewgraph)

How the BIPM Computes UTC from TAI

- Problem: 1 day= $24*60*60*9,192,631,700$ cs oscillations
 - What happens if the Earth slows down (or speeds up)?
- Compromise solution: Add and subtract seconds
 - Do not change the frequency of cesium atom
 - UTC=TAI+ integer number of seconds
 - Decided by Time Lords in 1971/2
- Additional second is called a *Leap Second*
 - So far, have only inserted, never subtracted a second
- Could add at the end of any month
 - But so far have only added at end of December or June
 - Decision is made by the Earth Rotation Service (IERS)
- Some people want to stop inserting leap seconds

Multi-Cultural Time

Free-running time scales: EAL(BIPM), A.1(USNO), AT1(NIST), TA(Lab_X)

- Based only on available clock data, with no overt steering

International Atomic Time (TAI) and Coordinated Universal Time (UTC)

- EAL is average of all “secondary standards”, or clocks that are not accurately and independently calibrated against definition of second.
- UTC is EAL after steering towards “primary frequency standards” of the PTB, NIST, SU, and BNM. Computed every month in 5-day points and distributed in middle of following month.
- UTC=TAI with leap seconds to correct for variable Earth rotation

Terrestrial Time (TT)

- UTC recomputed with hindsight, but offset by 32.184 seconds for historical continuity with Ephemeris time.

Real-time realizations of UTC

- Steered time scales such as UTC(USNO), UTC(NIST), UTC(Lab_X)

All are Atomic Time, as they all get time from atomic oscillations

What is Clock Steering?

Usually, adjusting the rate of a clock to bring its phase (time) or frequency closer to a reference clock.

But one can also step the clock in time (phase), or accelerate it by changing the frequency's rate of change

Steering Definitions

Synchronization

Alignment of two sources of time

Syntonzation

Alignment of two sources of frequency

Equivalent to

**Alignment of two sources of time,
except for unknown calibration bias**

Why do we steer clocks?

To create synchrony and syntony.

For most communication applications, syntony is all that is required.

For navigation and GPS synchrony is crucial, yet asyntony results in asynchrony

Omnipresence of Steering

TAI = EAL + frequency steers to primary frequency standards

(calibrated to meet definition of the second)

(EAL = ave of >200 clocks, including USNO's)

UTC = TAI + leap seconds

(crude steers, in phase, to Earth's rotation)

UTC(k) = TA(k) + steers to UTC = realization of UTC by laboratory k

(TA(k) = ave of Lab_k's clocks)

GPS* = Unsteered GPS clocks + steers to UTC(USNO) [in acceleration]

(Composite Clock= implicit average of steered satellite and monitor station clocks)

Telephone's Time = crystal + steers to UTC(k) or GPS*

Atomic Clock's time = clock's crystal + steers to atomic frequencies

(GPS* denotes GPS Time with leap seconds added)

Proportional Steering (similar to PID Steering)

Change frequency of clock by:
 G_X times its Time Offset
+ G_Y times its Frequency Offset



ALL steering involves a trade-off between frequency stability, time stability, and control effort. For proportional steering, Linear Quadratic Gaussian (LQG) theory can compute the optimal gains (G_X and G_Y) for your stability goals.

See Koppang and Leland, 1999, IEEE Trans. Ultrason. Ferroelect., Freq. Control 46, pp 517-522.

See also Appendix IV.

Improvement Due to Steering

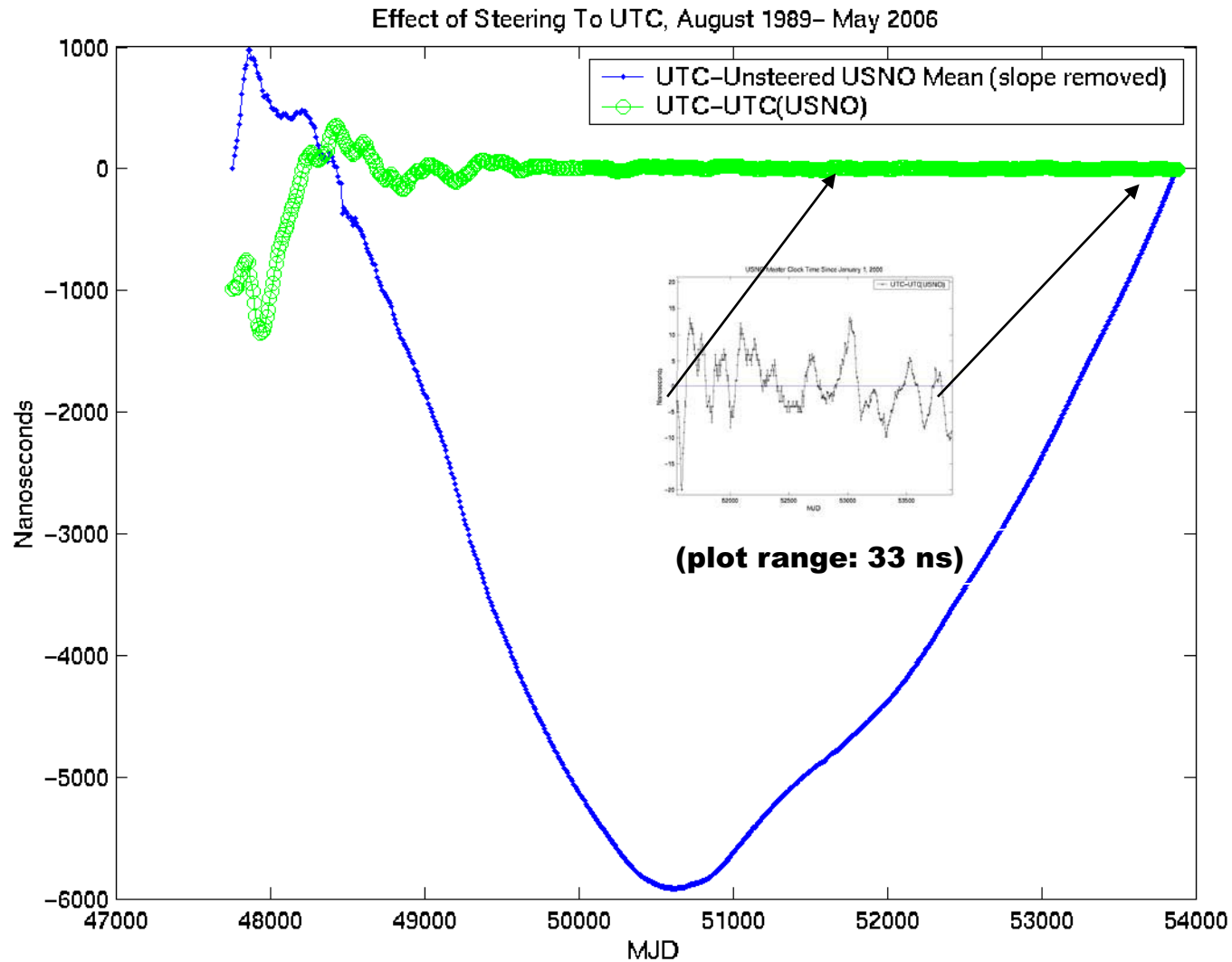

GPS Time Management/Steering

GPS Time Synchronization to UTC(USNO)

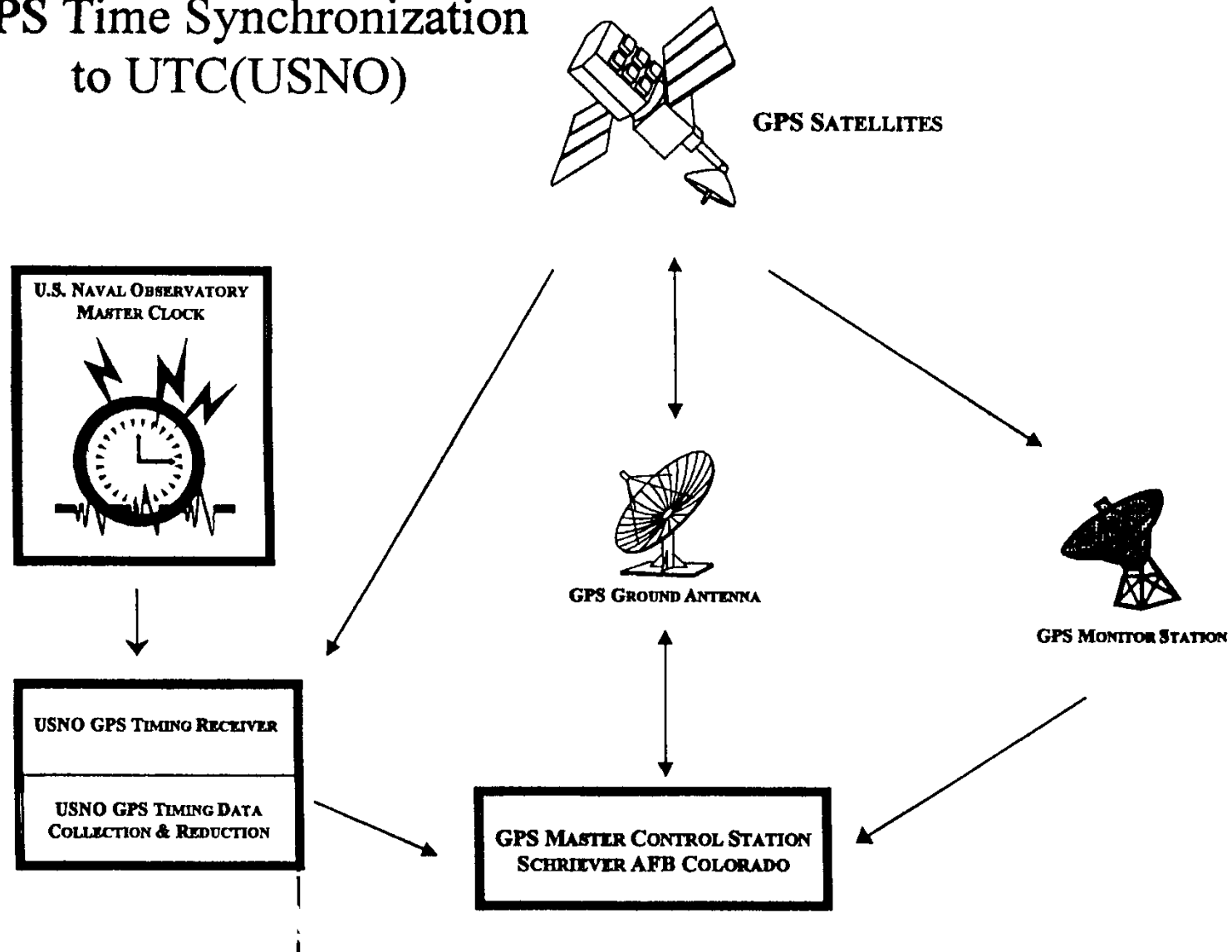

GPS Time As Measured, modulo 1 sec

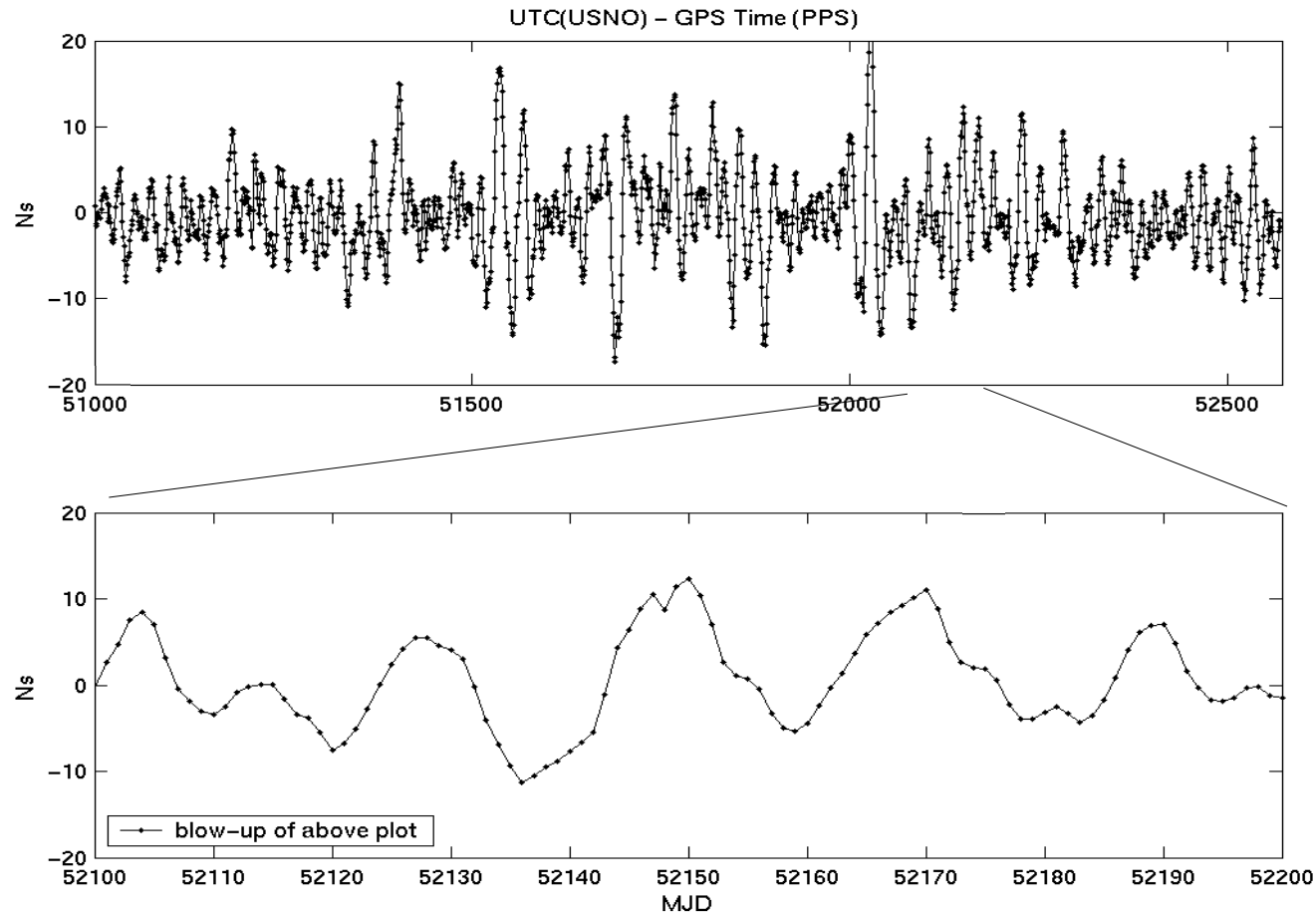

Broadcast Corrections to Correct to UTC(USNO) improve performance to almost 1 ns RMS.

GPS "Bang-bang": 3 examples

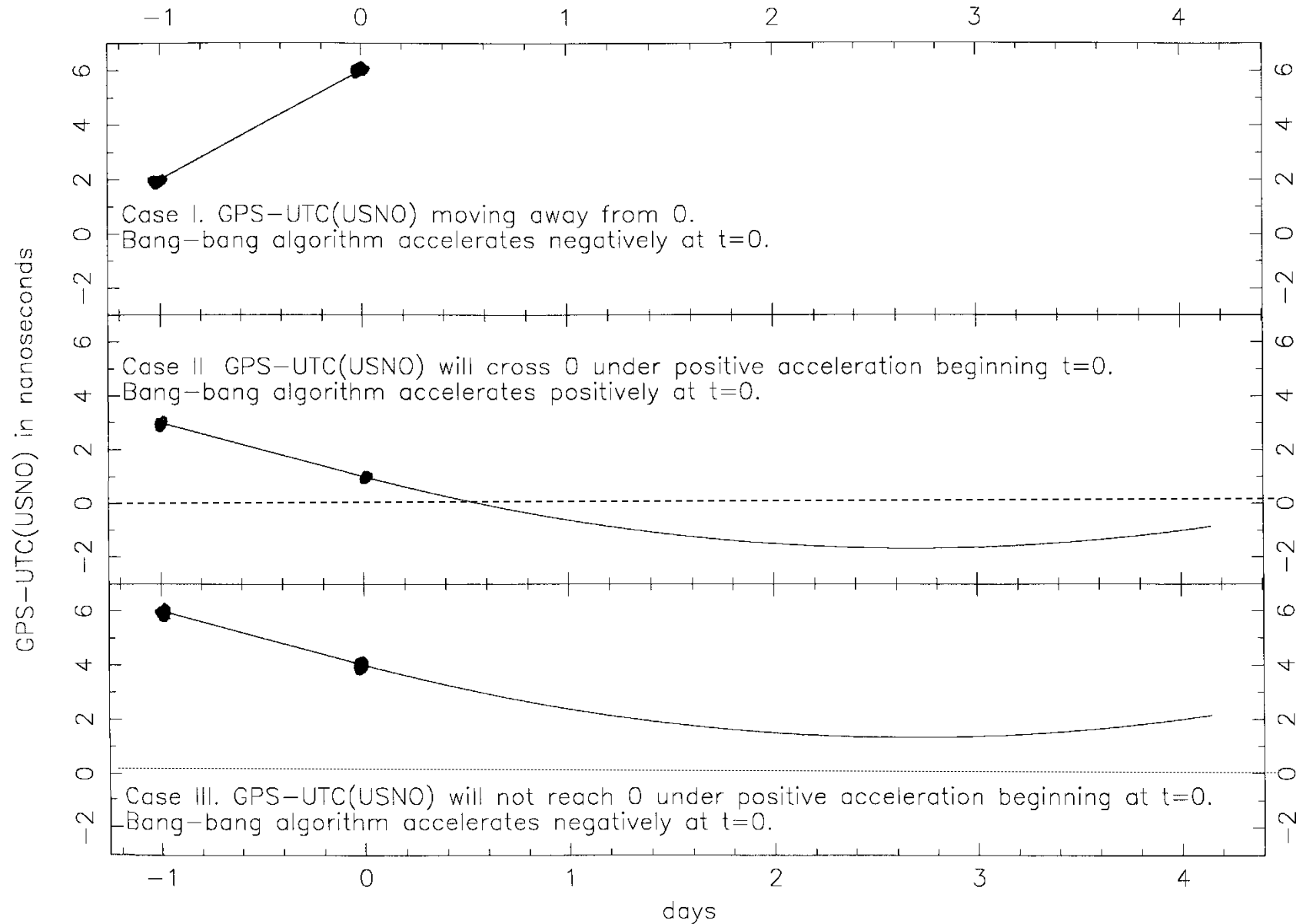

Time Transfer

Definition: The comparison of two sources of time.

Terminology: Clock (A) - Clock (B)

+ Value: Clock (A) is ahead of Clock (B)

- Value: Clock (B) is ahead of Clock (A)

Frequency Transfer

Definition: The relative change in time between two time sources.

$$[(\text{Clk}(A) - \text{Clk}(B))_{T_2} - (\text{Clk}(A) - \text{Clk}(B))_{T_1}] / (T_2 - T_1)$$

+ Value: Clk(A) is higher in frequency than Clk(B)

- Value: Clk(B) is higher in frequency than Clk(A)

The medium should not be the message ...

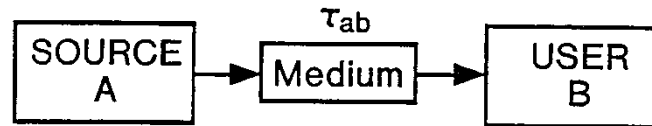

a) *One-Way Time Transfer*

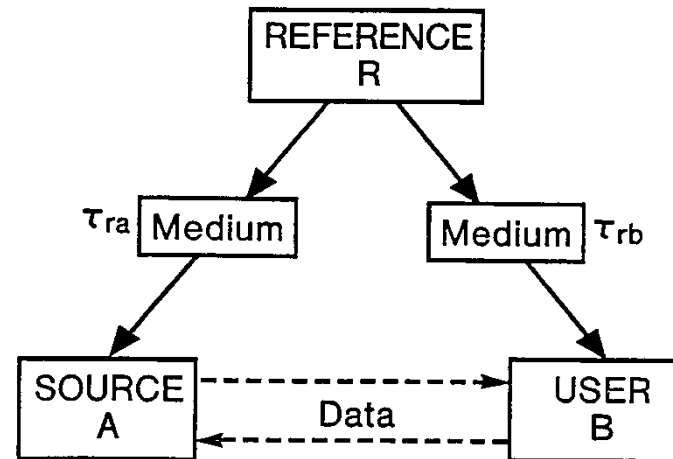

b) *Common-View Time Transfer*

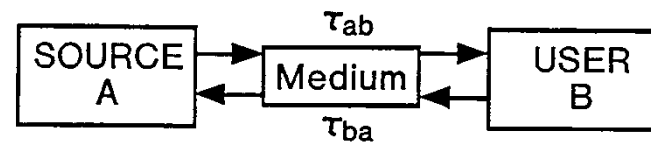

c) *Two-Way Time Transfer*

Time Balls



Operational for USNO: 1845 - 1936

Ceremonial at USNO: 2000 - ?

Telephone Time Transfer

I. Voice Announcers: 1 second at best

- human response time a factor

II. Modems: As good as 1 ms, provided

- Sender's system delay subtracted (USNO's delay is 1.7 +/- .4 ms)
- Can use remote loopback feature to measure line delay
- No satellite connection (would add about .25 seconds)

Network Time Protocol (NTP)

- Computer to Computer Time Transfer
 - via LAN or Internet
- Server synchronized to UTC (USNO) via GPS receiver, or to UTC (NIST) via modem, or directly to any realization of UTC
- User sends NTP signal to server, analyzes response to get time
 - Limited by non-reciprocity in path
 - If over LAN: <1 msec
 - If over Internet: 1-100 msec
 - Gets worse as number of hops increases
 - Vagaries of internet routing can result in long-lasting biases
 - Transoceanic can be much worse if go by wildly different routes

NTP Assumes Reciprocity

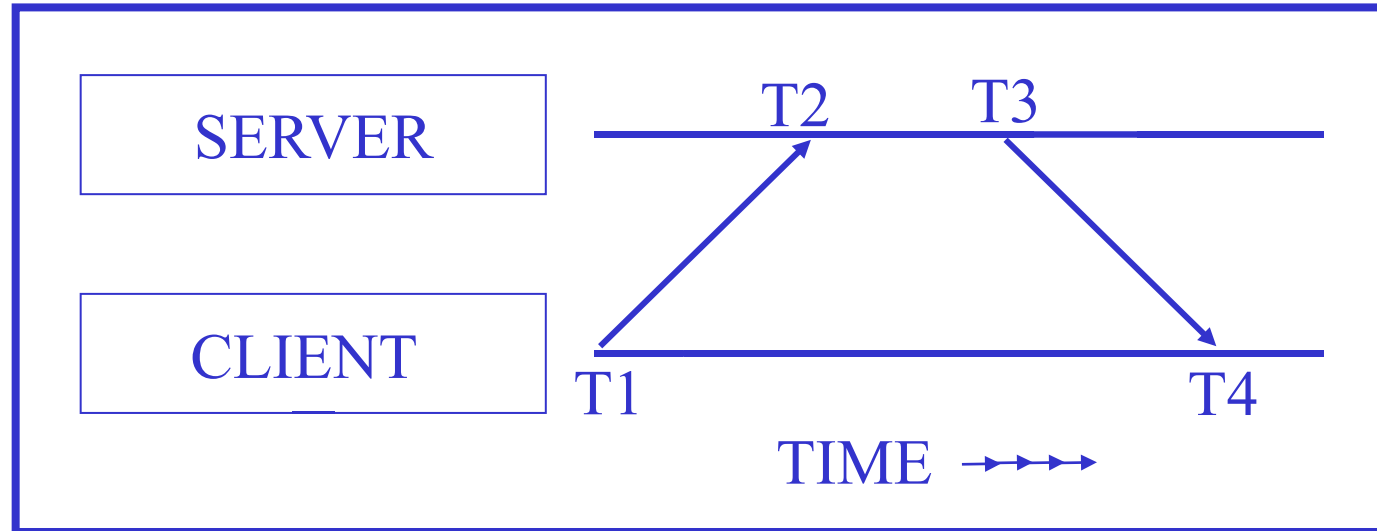

network delay:

$$\delta = (T_4 - T_1) - (T_3 - T_2)$$

clock offset:

$$\Theta = \frac{(T_2 - T_1) + (T_3 - T_4)}{2}$$

NTP: Illustrative Data

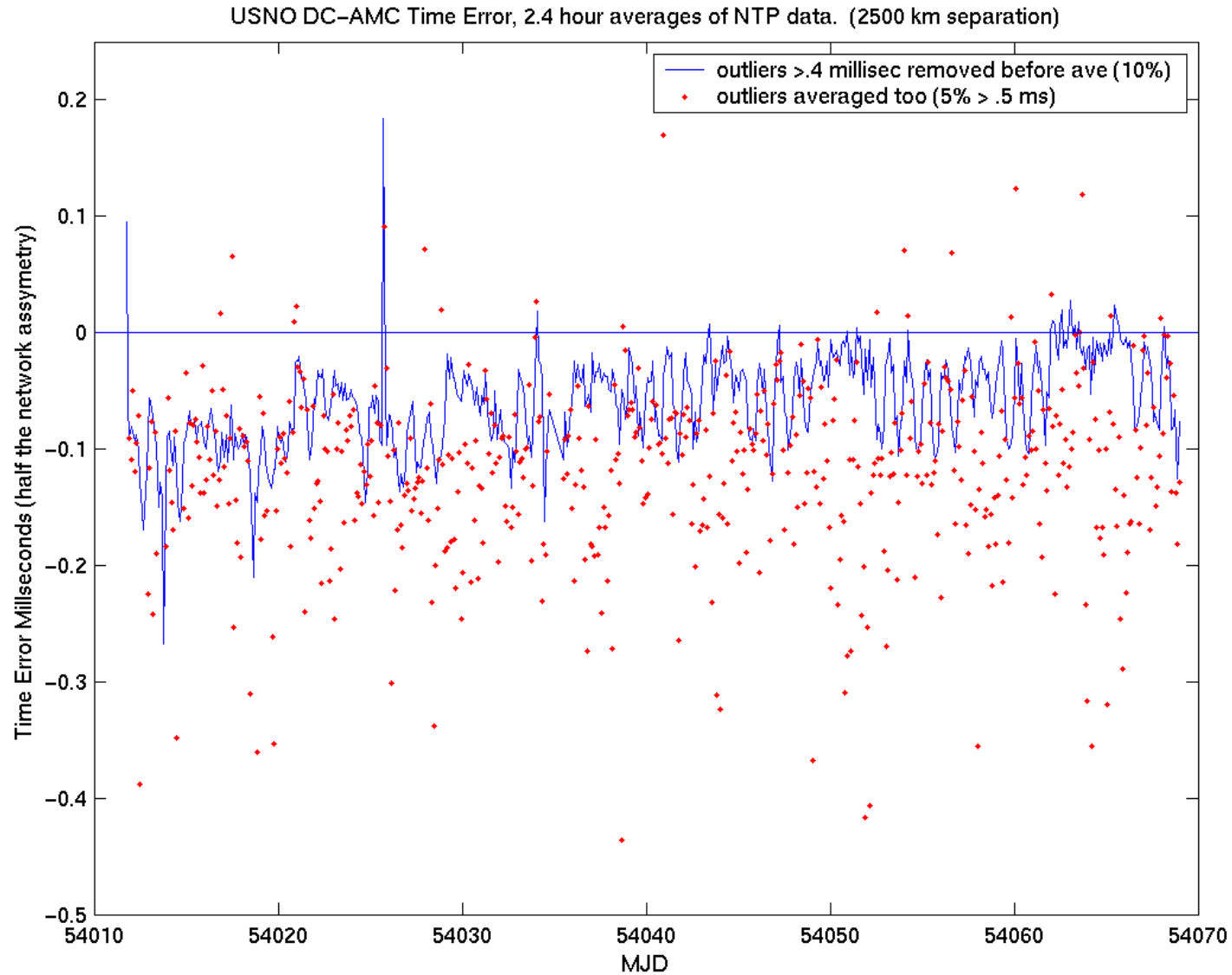

NTP Applications

- Millions of direct users
 - Such as your children and the White House
 - Unknown number of secondary users
- Some uses and applications of NTP
 - LAN networks – monitoring, control, database
 - Teleconferencing, radio and TV programming
 - Bank and stock market computers
 - Encryption
 - Time-stamping for patents, etc.
 - Interactive simulation
 - Electrical power grid synchronization

IEEE 1588, “Improved NTP”

- **Intended for small networks**
- **Fixed packet size,**
- **Keeps time-transfer processes at physical layer**
- **Each server sets its clock to that of closest server**
- **Only one route between servers**
 - **reciprocity is assured**
 - **impedes internet-wide applications**
- **Much greater precision: 20-100 ns**
- **Under development: <http://ieee1588.nist.gov>**
- **Large-network analog being initiated**
 - **See <http://www.dspscsp.com/tictoc>**

One-way Earth-based Radio Broadcasts

I. Low-Frequency (code only)

WWVB (NIST)

60 kHz

Accuracy: 500 microsec if
known location

Precision: 1 microsec

LORAN (U.S. Coast Guard)

100kHz

No time tags*

Use Time of Coincidence

Accuracy: <300 ns*

Precision: 100 ns*

Limited by weather patterns*

* E-Loran would have enhanced

Terminated Feb. 8, 2010

II. High-Frequency (code & voice)

WWV and WWVH (NIST)

CHU (Canada)

2.5-20 MHz

Accuracy: a few milliseconds

Limited by number of
ionospheric hops in travel
path

III. European and Asian Services

DCF77 (Germany)

77.5 kHz

http://www.ptb.de/en/org/4/44/442/DCF77_1_e.htm

Detailed View Of Individual Loran Pulse

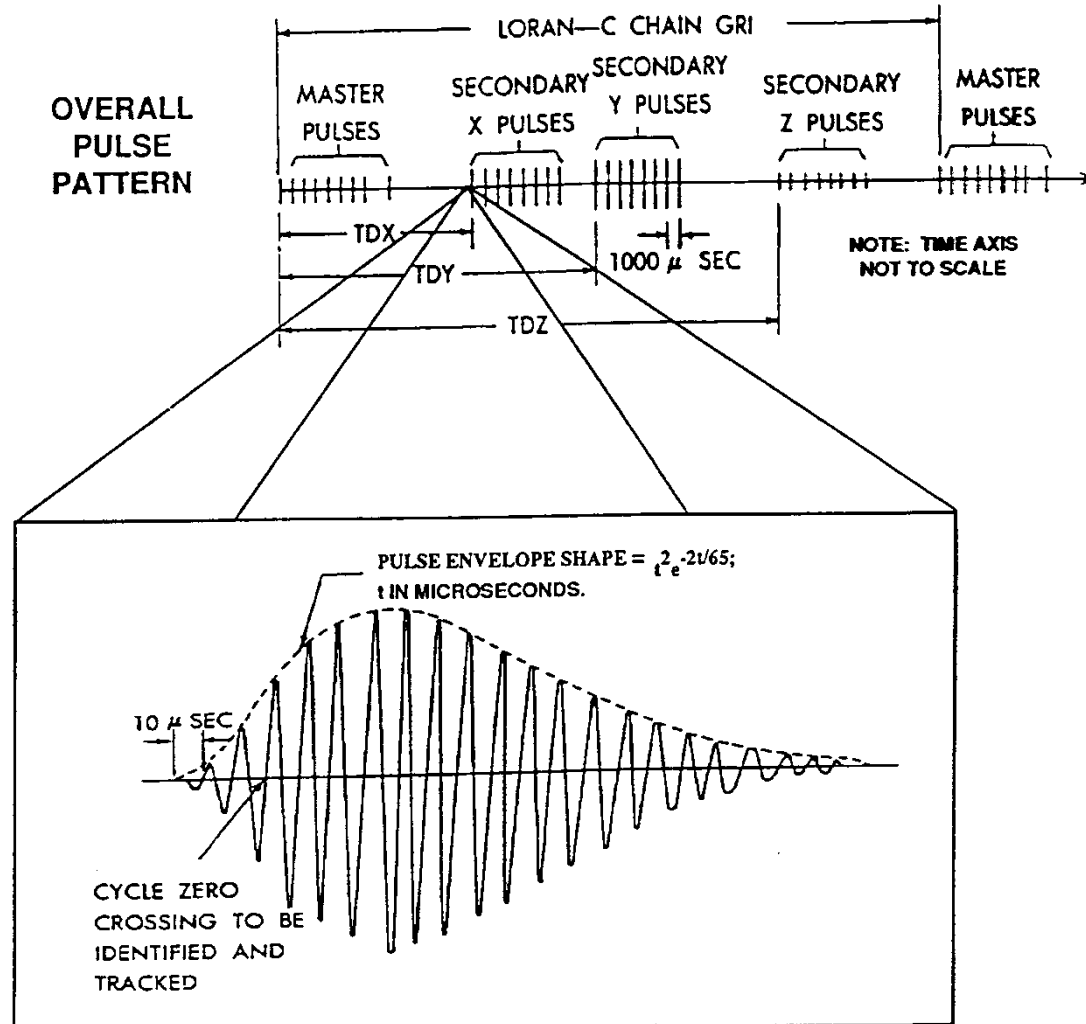

Enhanced Loran

- LORAN shut down in USA on February 8, 2010
 - Formal cut off was supposed to be end of 2000
- Better clocks at transmitters
- All-in-view rather than chain concept
- Users can have H-field (static free) antennas
- Broadcasts GPS corrections
- Broadcasts time directly
- Broadcasts more refined Loran corrections

Time is at the Core of GPS

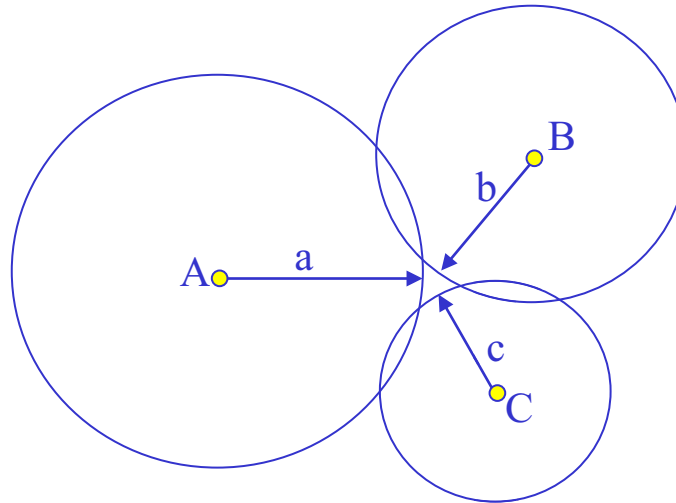

GPS receivers measure distance from satellites A, B, and C by the pseudoranges a , b , and c . Pseudoranges are measured as travel times, and converted to distances.

If the receiver is at known position and calibrated, time can be obtained from observing one satellite.

If the receiver's time is known and its timing delays are calibrated, its antenna's position is at the intersection of spheres centered on the satellites with radii a , b , and c .

If the receiver's time and position are not known, they can be inferred from observations of four satellites - but the time offset must be calibrated.

GPS Timing Receivers

- Extract either UTC (USNO) or GPS Time
 - GPS Time is for navigational solutions only and does not include leap seconds
 - Users who mistake GPS time with UTC sometimes think their receiver is off by 10's of seconds.
- Time Comparison: 2 ways
 1. Receiver's internal time interval counter
(You input your own signal, it compares)
 2. Receiver's output 1-PPS signal
(You compare to your own signal, externally)

Receiver Calibration: 2 ways

1. Absolute Calibration

2. Relative Calibration

Absolute Calibration

Determine Receiver Component Delays

- antenna delay
- antenna cable delay
- receiver internal delays
- delays to any external measurement systems

Calibrated GPS Simulator Required

Relative Calibration

Determine correction relative to a standard receiver through “side-by-side” comparisons

Relative Calibration

- Common clock
- Common antenna, or precise antenna coordinates
- Track same satellites with both receivers

Time Transfer via GPS

- Direct Access
 - Observe time directly off GPS code
 - Best to average over satellites
- Melting Pot or All-in-View
 - Average over satellites and/or time to obtain GPS-Clock
 - $\text{ClockA} - \text{ClockB} = (\text{GPS} - \text{ClockB}) - (\text{GPS} - \text{ClockA})$
- Common View
 - Averages difference with individual satellites instead of differencing the average of individual satellites
 - $\text{ClockA} - \text{ClockB} = \text{AVE}\{(\text{Sat}_i - \text{ClockB}) - (\text{Sat}_i - \text{ClockA})\}$

GPS Common-View

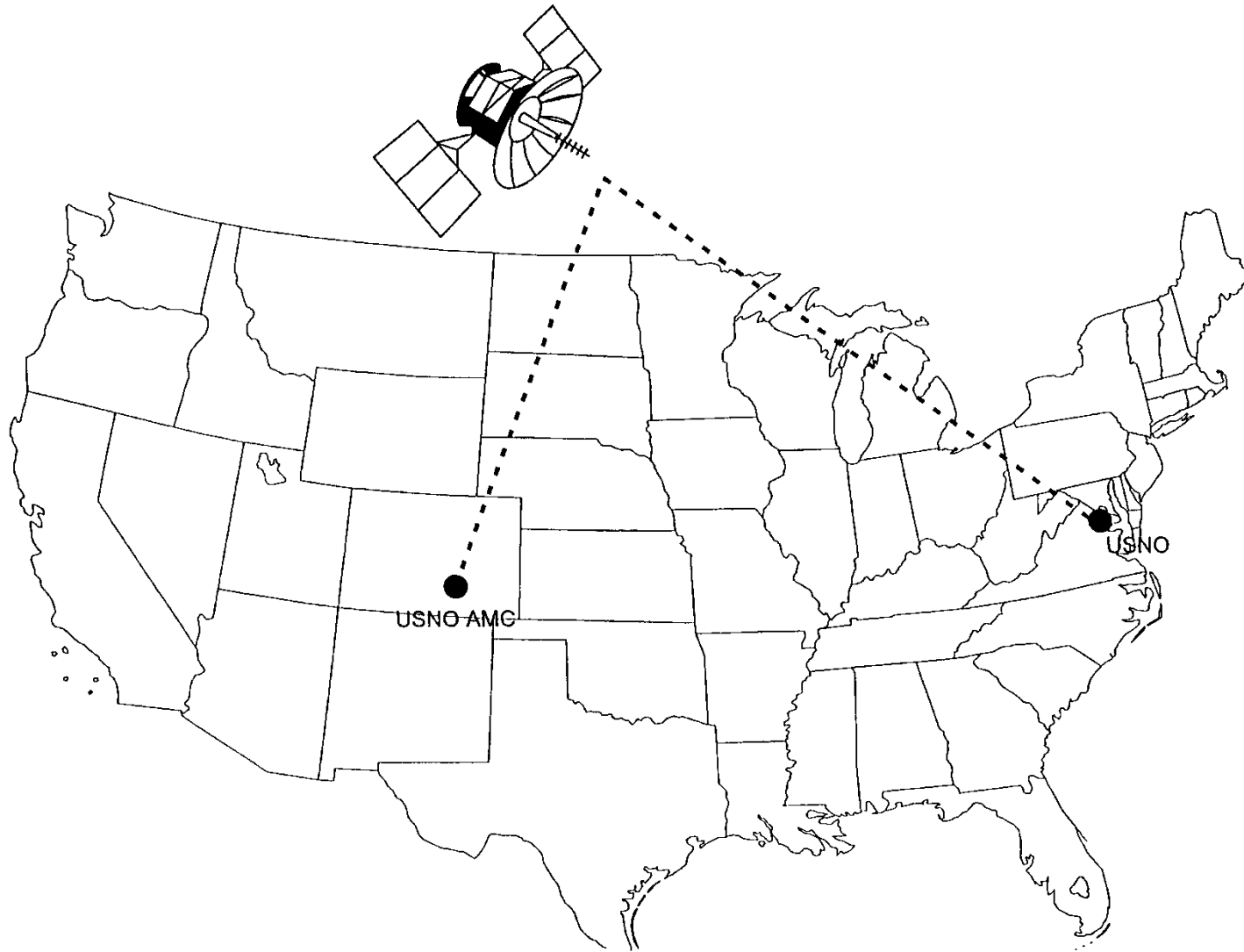

Some Sources of Error

Multipath

Calibration

Environment (temp, humidity, etc.)

Ionosphere & Troposphere Corrections

Antenna position

Satellite clock errors

Satellite position (orbit) errors

Ionospheric Modeling Geometry

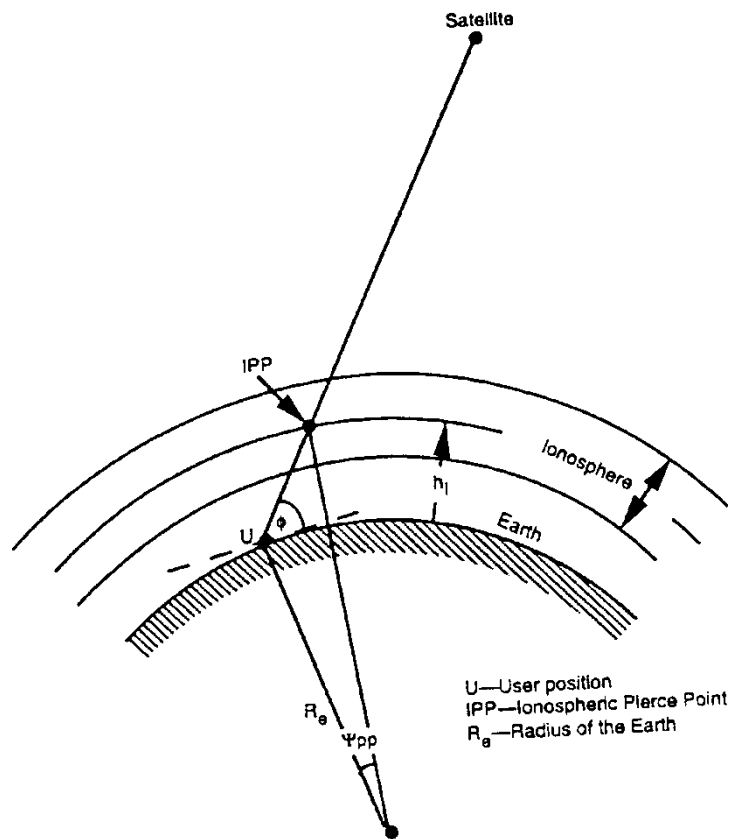

- Highly variable
 - 11-year cycle
 - Much less at night
 - Latitude (and longitude) dependant
 - Stronger at low satellite elevation
- Klobuchar model (broadcast)
 - ballpark accuracy: 10 ns
- Wavelength-dependent (L1 vs. L2)
 - Allows very exact removal
 - If you have two-frequency data
 - Civilians will shortly have two-frequency data from L5
 - Carrier phase techniques can infer

Dry and Wet Components of the Troposphere

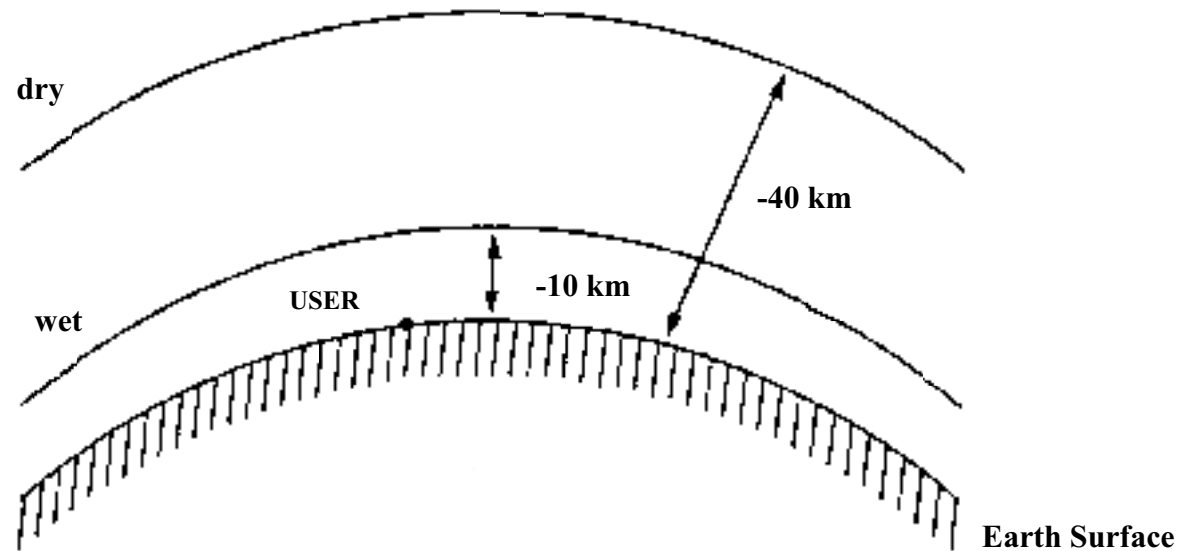

6.6 nanoseconds vertical delay, on average. Stronger at low elevations
90% due to nitrogen, proportional to ground pressure.

10% due to water, not proportional to ground humidity and anti-correlated with ground pressure. Can fit using elevation dependence.

Price of mismodeled atmosphere and/or ionosphere:

- You will get the wrong time and the wrong position, and the error will be systematic
- The position offset will mostly be in the vertical direction (if you observe GPS satellites evenly over the sky).

Multipath

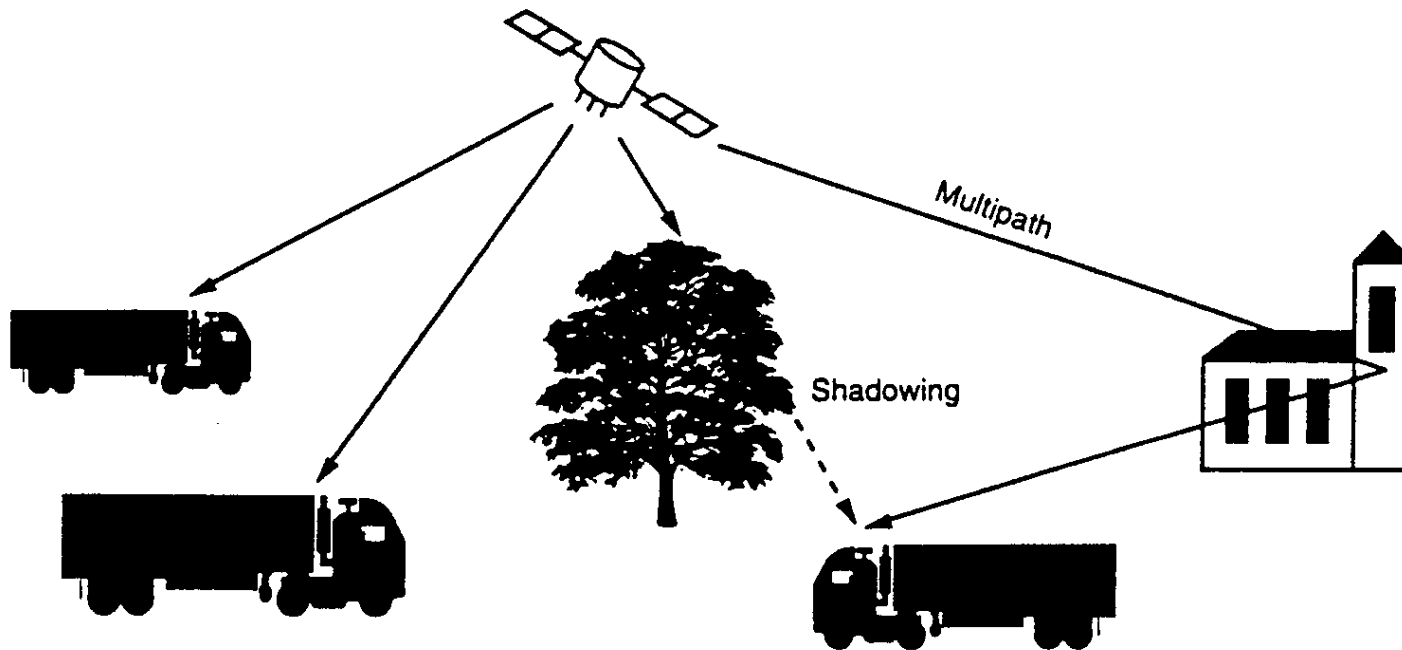

Multipath

- Optimal antenna location:
 - ground level
 - empty parking lot
- Receivers have rejection algorithms
- Affects code more than phase
- Actually helps in urban canyons!
“better late than never”

GPS Carrier-Phase

SIGNALS/OBSERVABLES

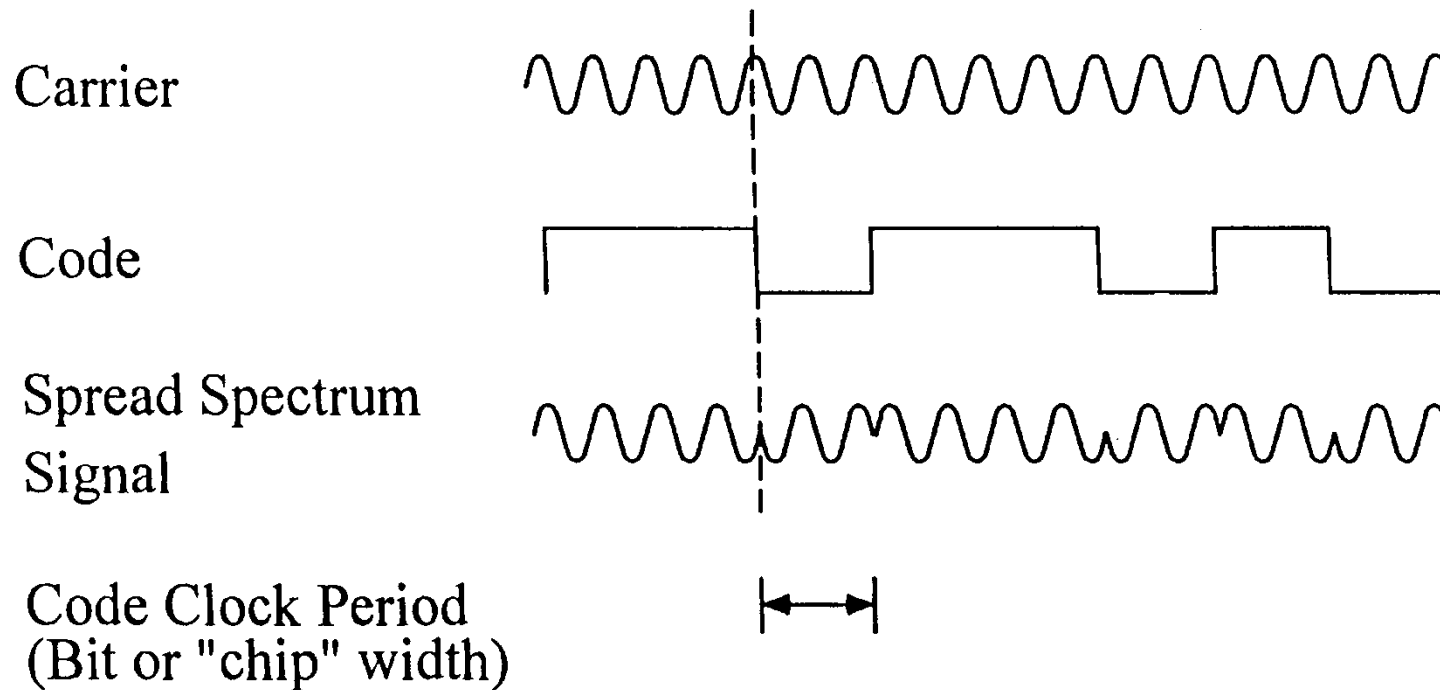

GPS C/A Code Transition

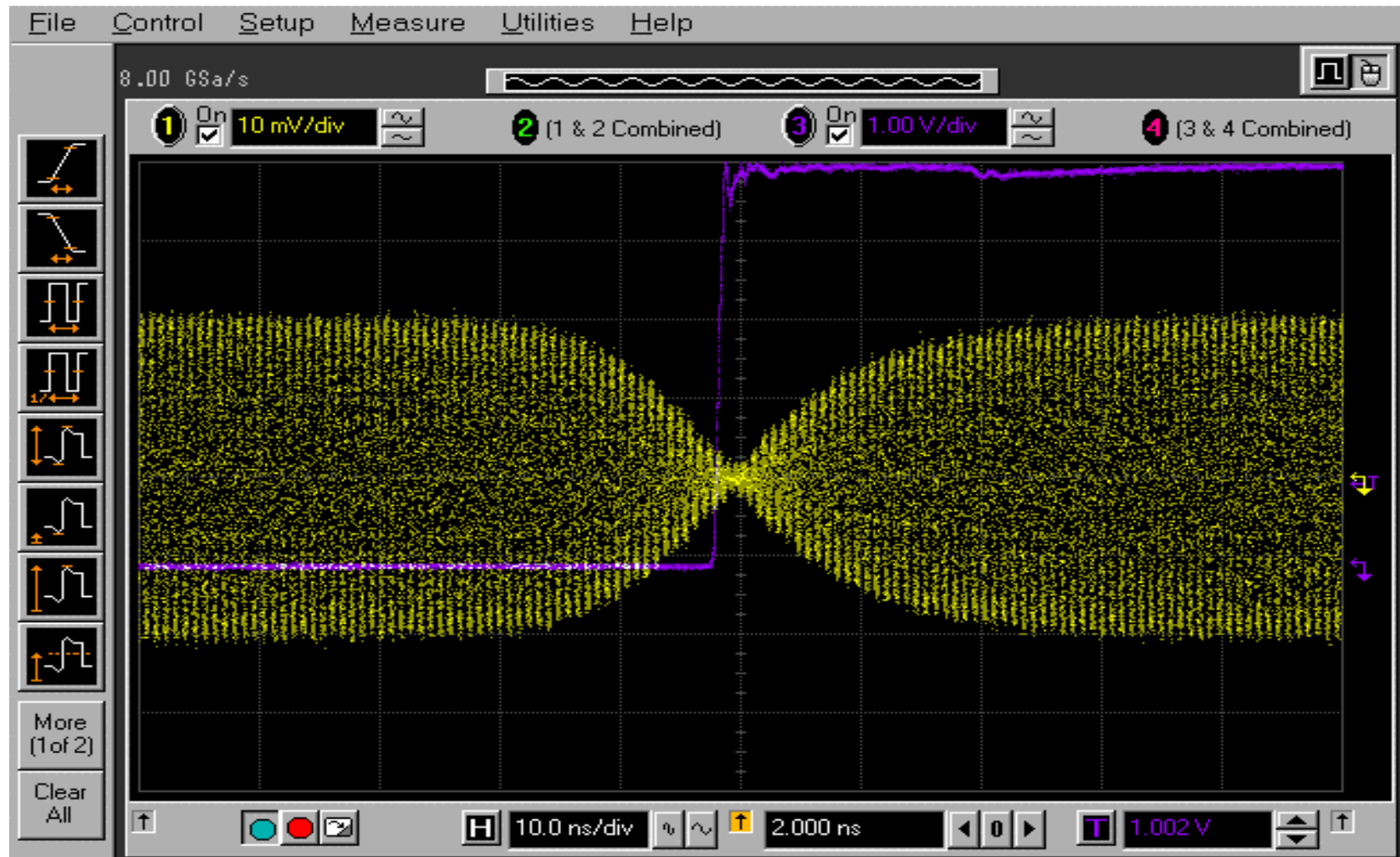

Source: Powers et al., EFTF-02

GPS Carrier-Phase Time Transfer

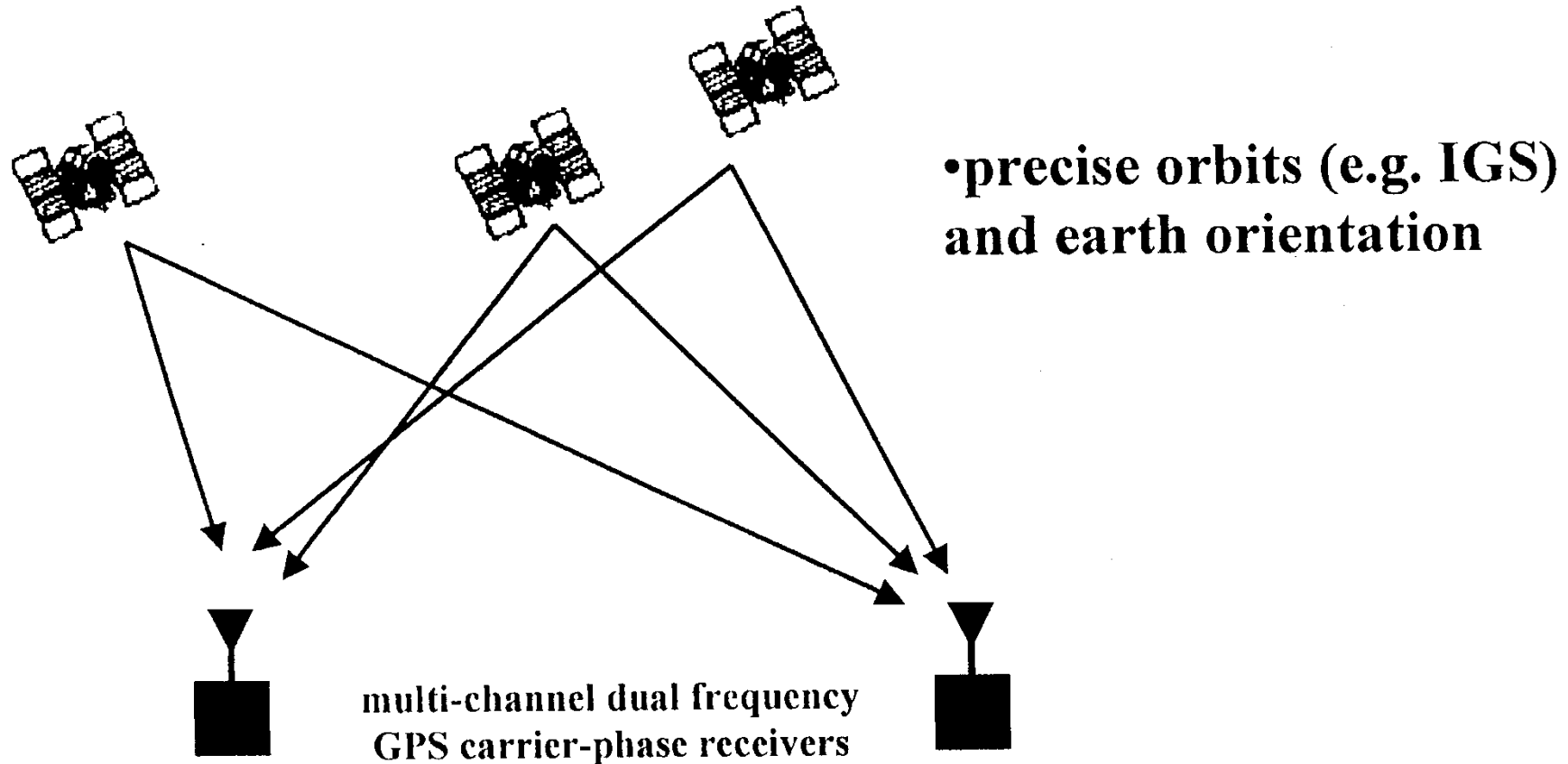

calibration ~ ??

precision ~ 10ps

accuracy < 1ns (?)

International GNSS Service

Formerly the International GPS Service



International Governing Board



NAVSTAR GPS Satellites
GLONASS
Future Galileo
Galileo System Test Bed

Global Data Centers

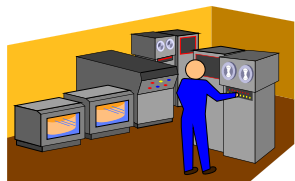

Analysis Center Coordinator



Analysis Centers

Reference Frame, Network, and Timing Coordinators



Global & Regional Network and Associate Analysis Centers

IGS Projects and Working Groups

- IGS Reference Frame Working Group
- Precise Time & Frequency Transfer
- GLONASS Pilot Service Project
- Low Earth Orbiters Project
- Ionosphere WG
- Atmosphere WG
- Sea Level - TIGA Project
- Real-Time WG
- Data Center WG
- GNSS WG

Operational & Regional Data Center



INTERNET



Various communication links



USERS

Practical, Custom, Commercial, Governments,...

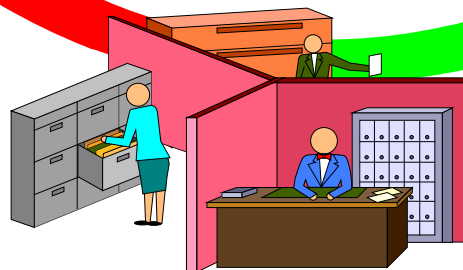

Central Bureau at NASA/JPL

Management, Network Coordination, External Relations, IGS Information System

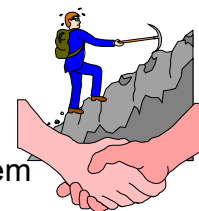

SATELLITE LINK



GPS Stations

<http://igscb.jpl.nasa.gov>

WAAS for Time Transfer

Satellites at fixed position, so

- Can use directional antenna
 - harder to jam
- Can use high-gain antenna
 - more signal to noise
- Continuous coverage
 - carrier-phase simplified
- Steered to GPS time, UTC (USNO)
 - excellent backup potential

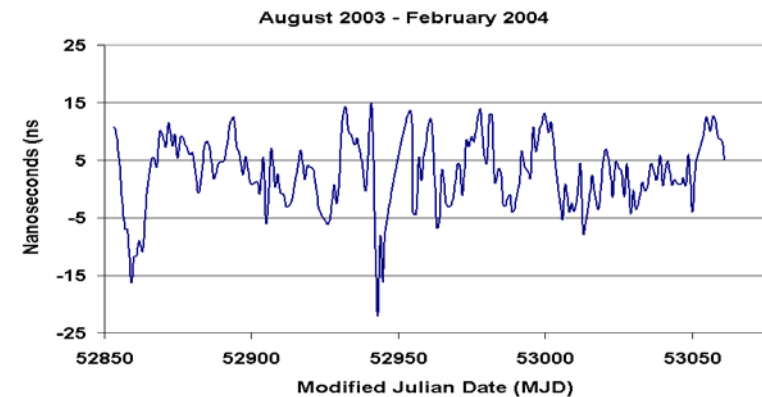

**UTC(USNO)-WAAS NT
(offset removed)**

Two-Way Satellite Time Transfer

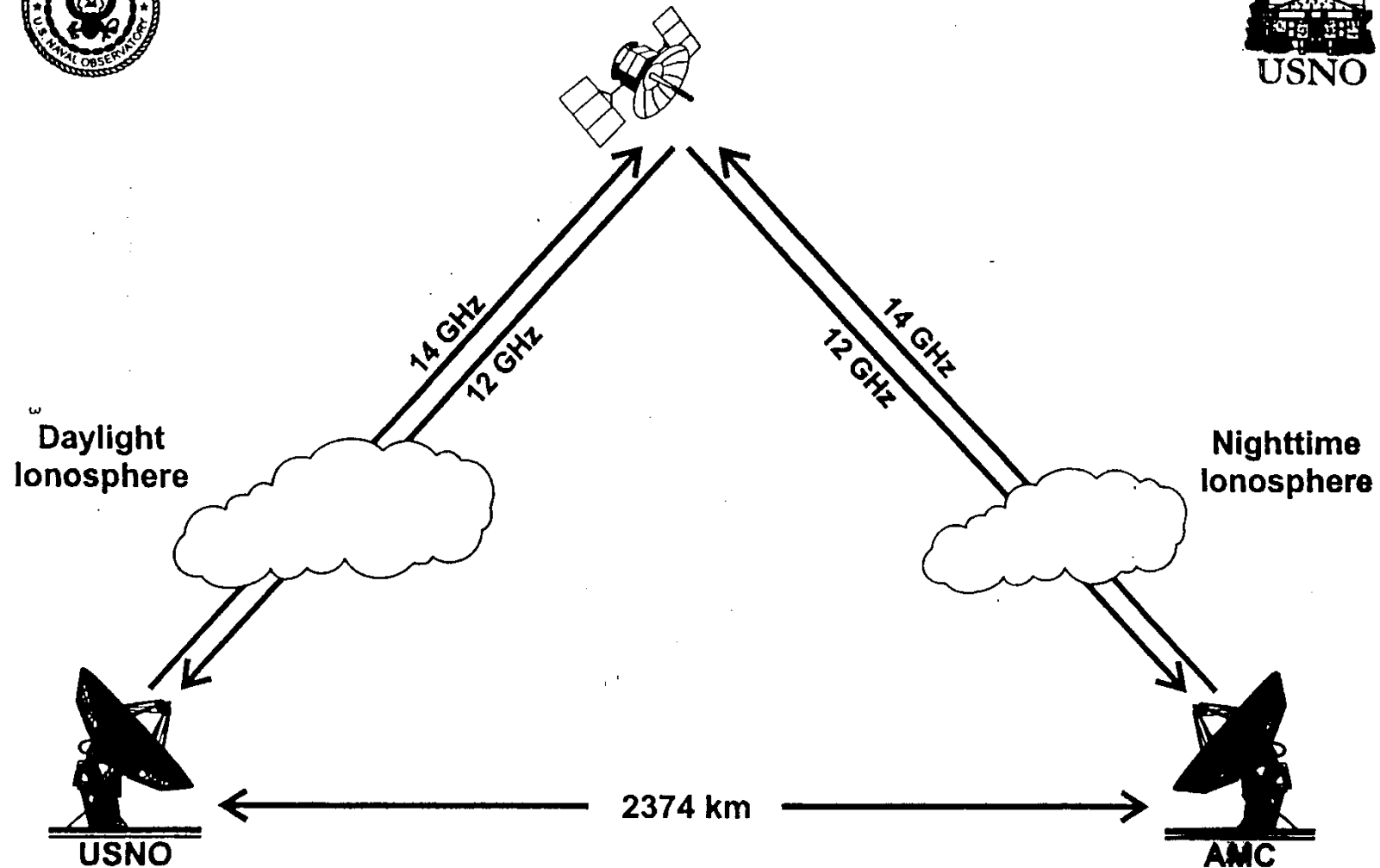

USNO Two-Way Satellite Time Transfer Earth Terminals



USNO BASE STATION ANTENNAS



USNO MOBILE EARTH STATION

Sagnac Effect

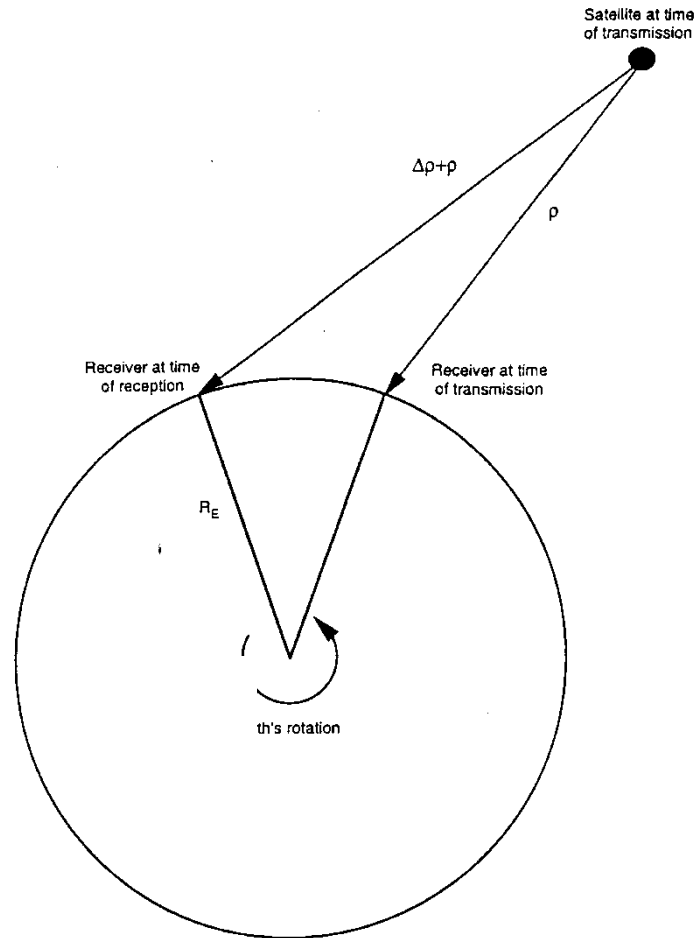

Galilean, not “relativistic frame-dragging”

TDEV for Time Transfer Modes

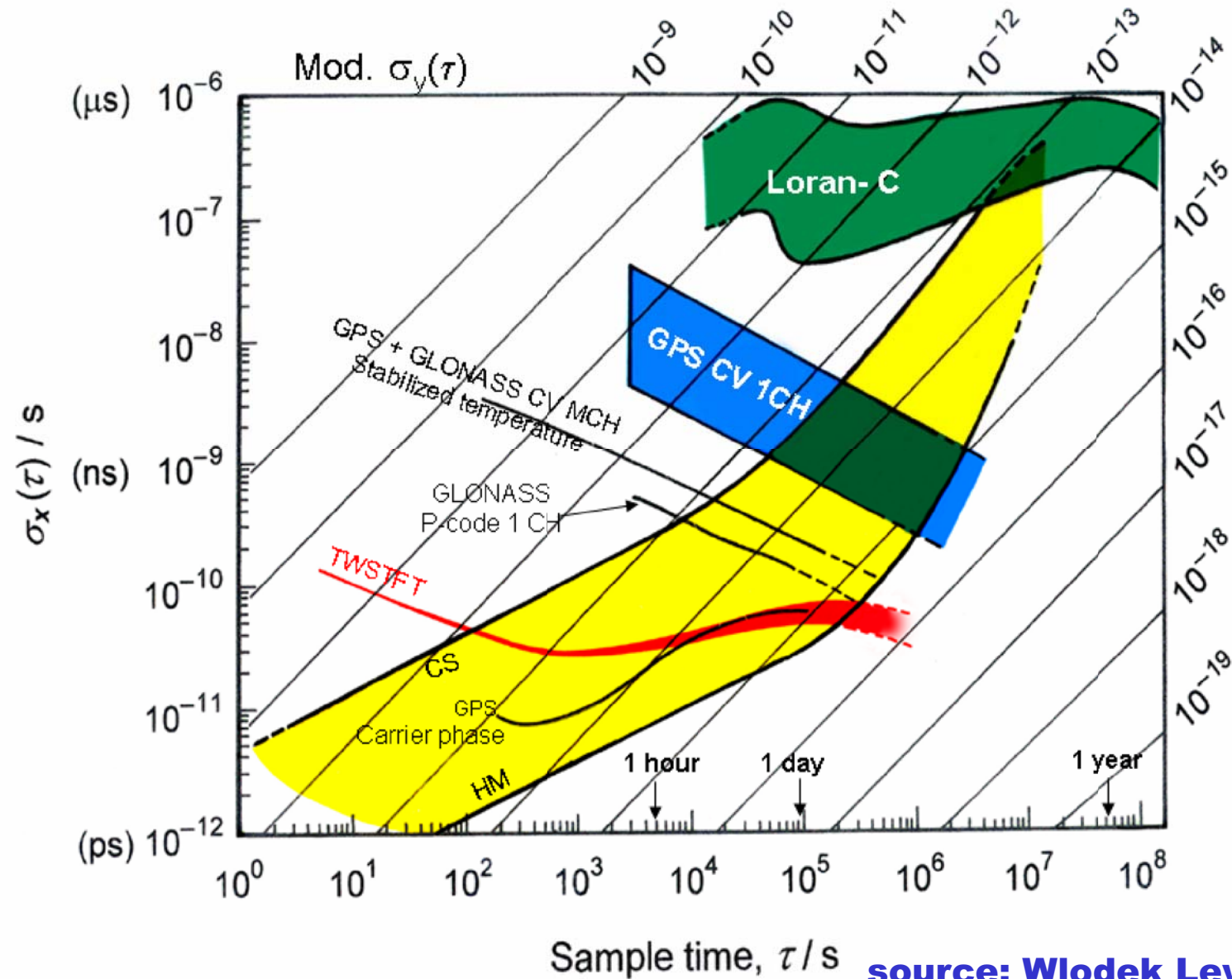

source: Wlodek Lewandowski

GPS Frequency and Time Users

Communications and IT

- Cell phones and pagers
- Large bandwidth transmissions
- Network Time Protocol (NTP)
- Satellite communication systems
- Military communication systems

Surveillance

- Space debris, and worse
- Missile launches, good and bad
- Nuclear explosion detections

Science and Engineering

- Power Grid Synchronization
- Generation of UTC
- Very Long Baseline Interferometry
- Pulsar Observations
- Neutrino detectors
- Gravity Wave Search
- DoD and Civilian Laboratories *
- Earth rotation, UT1 *
- Ionosphere measurements *
- Troposphere measurements *

*use GPS carrier-phase data

Appendices

- I. Parade of Clocks
- II. Philosophy of Time (and Relativity)
- III. Statistical Details
- IV. Timescale Details
- V. Control Theory
- VI. Time Transfer Details

Appendix I: Parade of Clocks

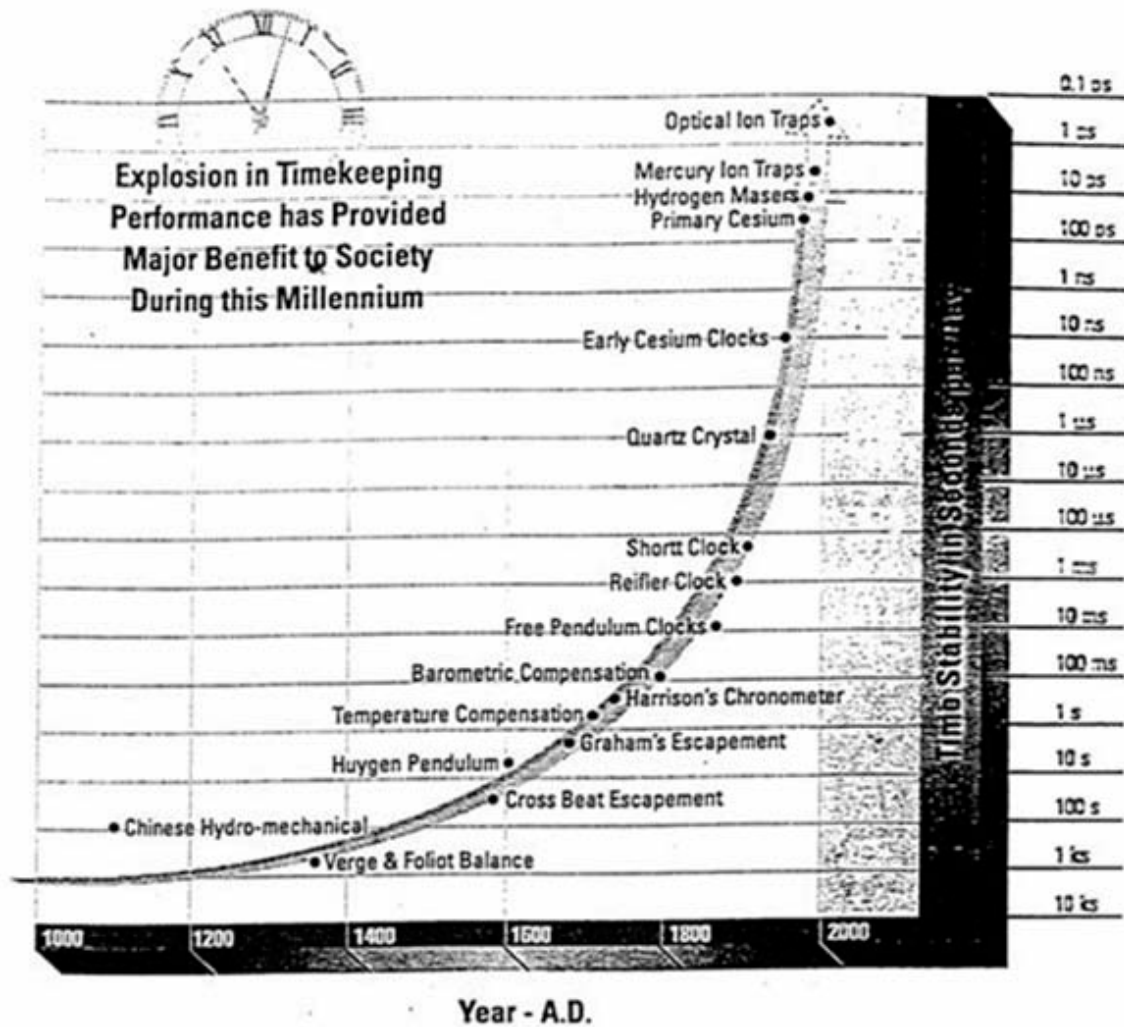

Source: Hewlett-Packard Appl. Note 1289

Each one has a High-Tech aspect

Rotating Earth: sundials => hour angle, seasonal corrections

Water clocks: Sung Dynasty's Time Service

Spring-loaded clocks: escapements serve to regulate

Pendulum clocks: master/slave (master/disciplined oscillator)
nitrogen/air conditioning

Quartz clocks: pure crystals to resonate, temperature-controlled

Rotating Earth: stars with photographic zenith tubes

-> quasars with Very Long Baseline Interferometry

Atomic Clocks

- Cesium Standards: beam tubes => fountains
- Hydrogen Masers: cavity-tuned
- Trapped Ions: spherical => linear trap
many ion => single ion => coherent few-ion
- Optical Frequency Standard
Optical Comb

Rotating Neutron Stars (pulsars)

- pulsar => millisecond pulsar

Stonehenge: ~2975 BC

