

2499-15

**International Training Workshop on FPGA Design for Scientific
Instrumentation and Computing**

11 - 22 November 2013

**Digital CMOS Design
Adders**

Pirouz Bazargan-Sabet
*Department ASIM, LIP6
University Pierre & Marie Curie (VI), 4
place Jussieu, 75252 Paris Cedex 05
France*

Outline

- ❑ Digital CMOS design
- ❑ Arithmetic operators
- ❑ Sequential functions



Outline

- Digital CMOS design

- Arithmetic operators

 - Adders

 - Comparators

 - Shifters

 - Multipliers

Adders

Adding two natural numbers

Let consider two natural numbers a and b coded on 8 bits using Natural Binary Code

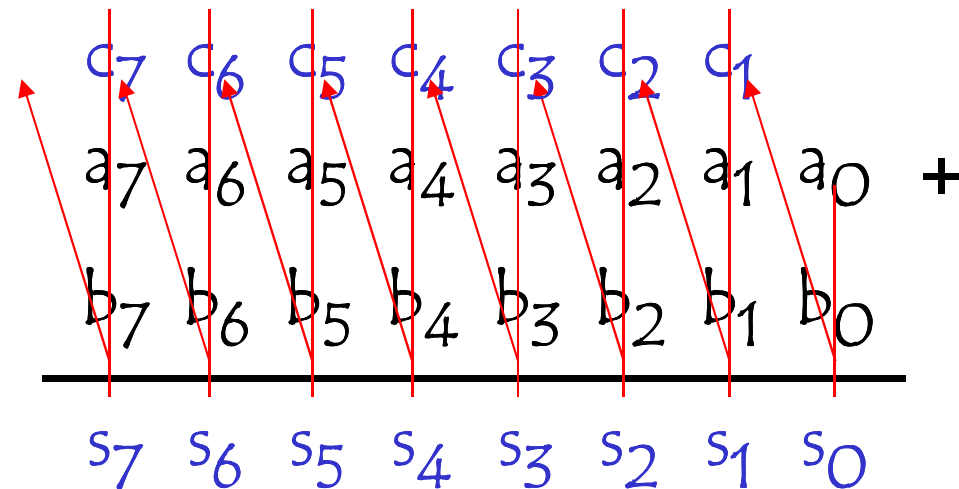

Adders

Adding two natural numbers

At each stage, I need to sum 3 single bit numbers a_i b_i c_i

The carry out of the stage i is the input carry of the next stage

$$\begin{array}{r} c_{i+1} c_i \\ a_i + \\ b_i \\ \hline s_i \end{array}$$

s_i and c_{i+1} are Boolean functions of a_i b_i c_i

Adders

Adding two natural numbers

	00	01	11	10	$a_i b_i$
0	0	1	0	1	
1	1	0	1	0	

c_i s_i

$$s_i = a_i \oplus b_i \oplus c_i$$

	00	01	11	10	$a_i b_i$
0	0	0	1	0	
1	0	1	1	1	

c_i c_{i+1}

$$c_{i+1} = a_i \cdot b_i + a_i \cdot c_i + b_i \cdot c_i$$

Adders

Adding two natural numbers

$$s_i = a_i \oplus b_i \oplus c_i$$

$$c_{i+1} = a_i \cdot b_i + a_i \cdot c_i + b_i \cdot c_i$$

$$c_{i+1} = a_i \cdot (b_i + c_i) + b_i \cdot c_i$$

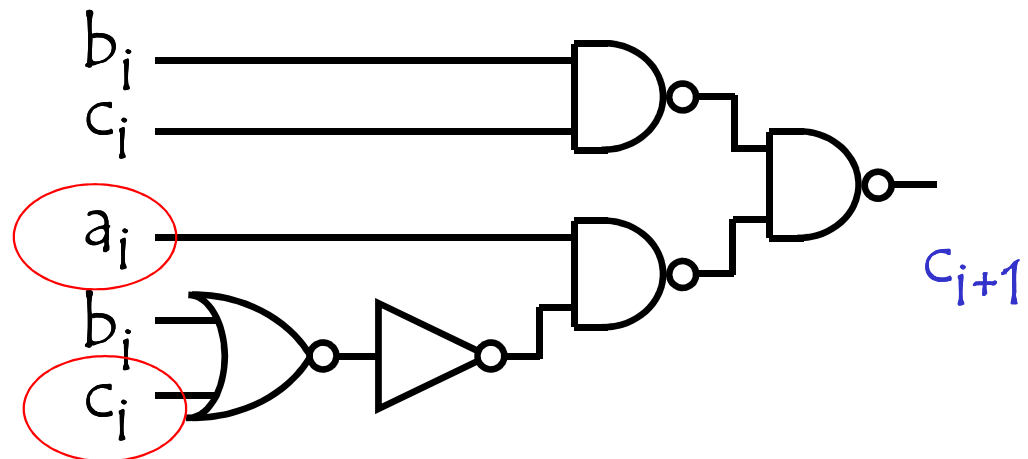
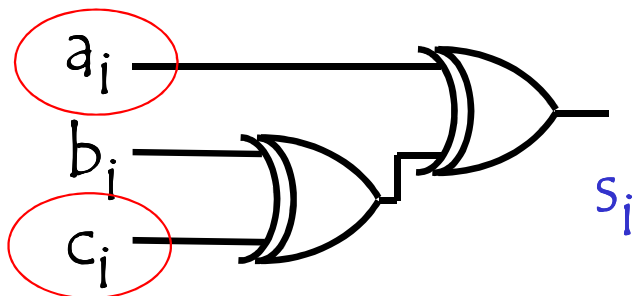

Adders

Adding two natural numbers

$$s_i = a_i \oplus b_i \oplus c_i$$

$$c_{i+1} = a_i \cdot b_i + a_i \cdot c_i + b_i \cdot c_i$$

$$c_{i+1} = a_i \cdot b_i + (a_i + b_i) \cdot c_i$$

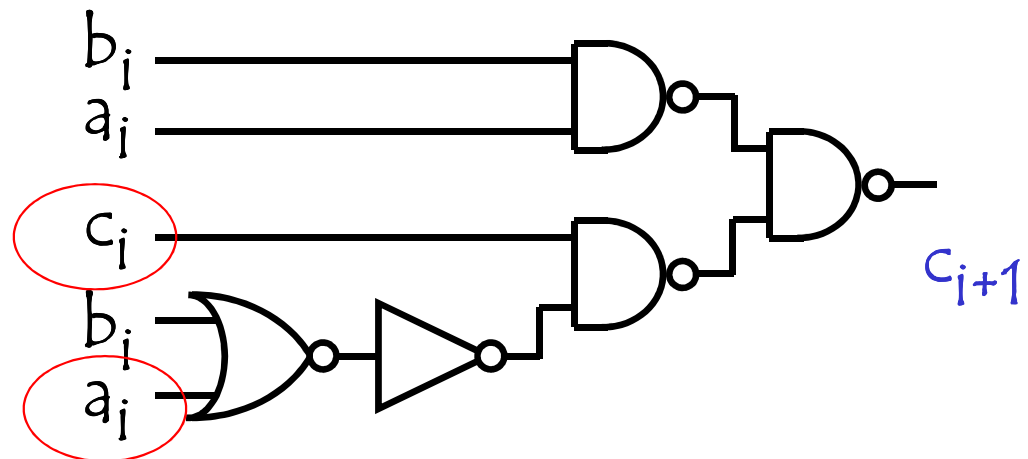
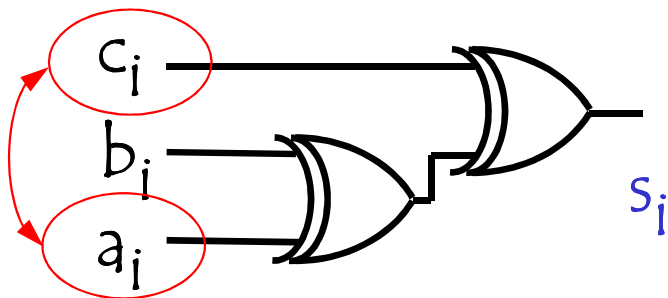

Adders

Adding two natural numbers

$$s_i = a_i \oplus b_i \oplus c_i$$

$$c_{i+1} = a_i \cdot b_i + a_i \cdot c_i + b_i \cdot c_i$$

$$c_{i+1} = a_i \cdot b_i + (a_i + b_i) \cdot c_i$$

$$c_{i+1} = a_i \cdot b_i + (a_i \oplus b_i) \cdot c_i$$

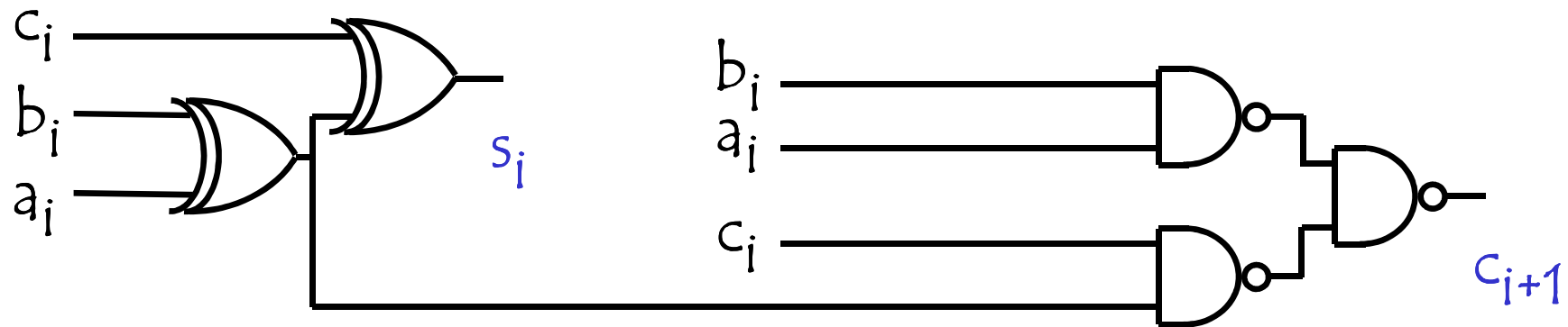

Adders

Adding two natural numbers

The circuit generating s_i and c_{i+1} is called a Full Adder (FA)

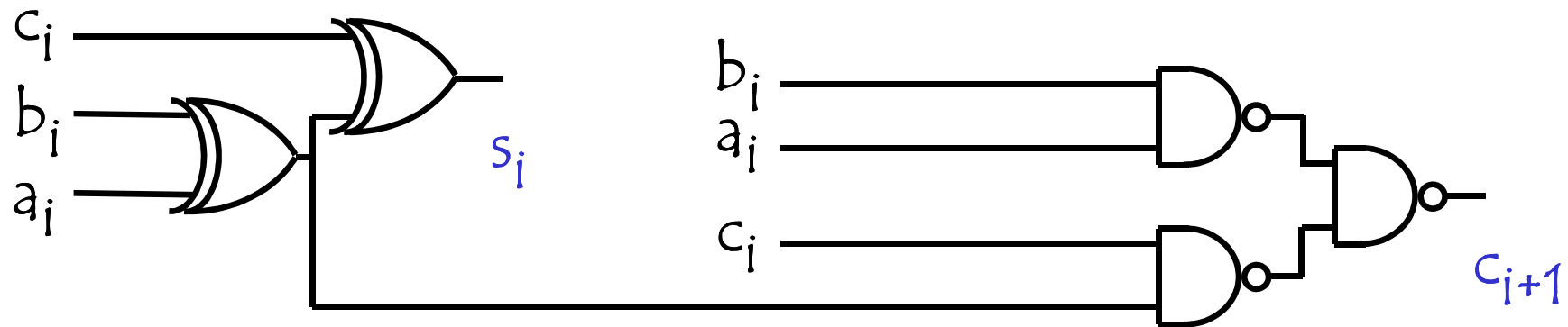

Adders

Adding two natural numbers

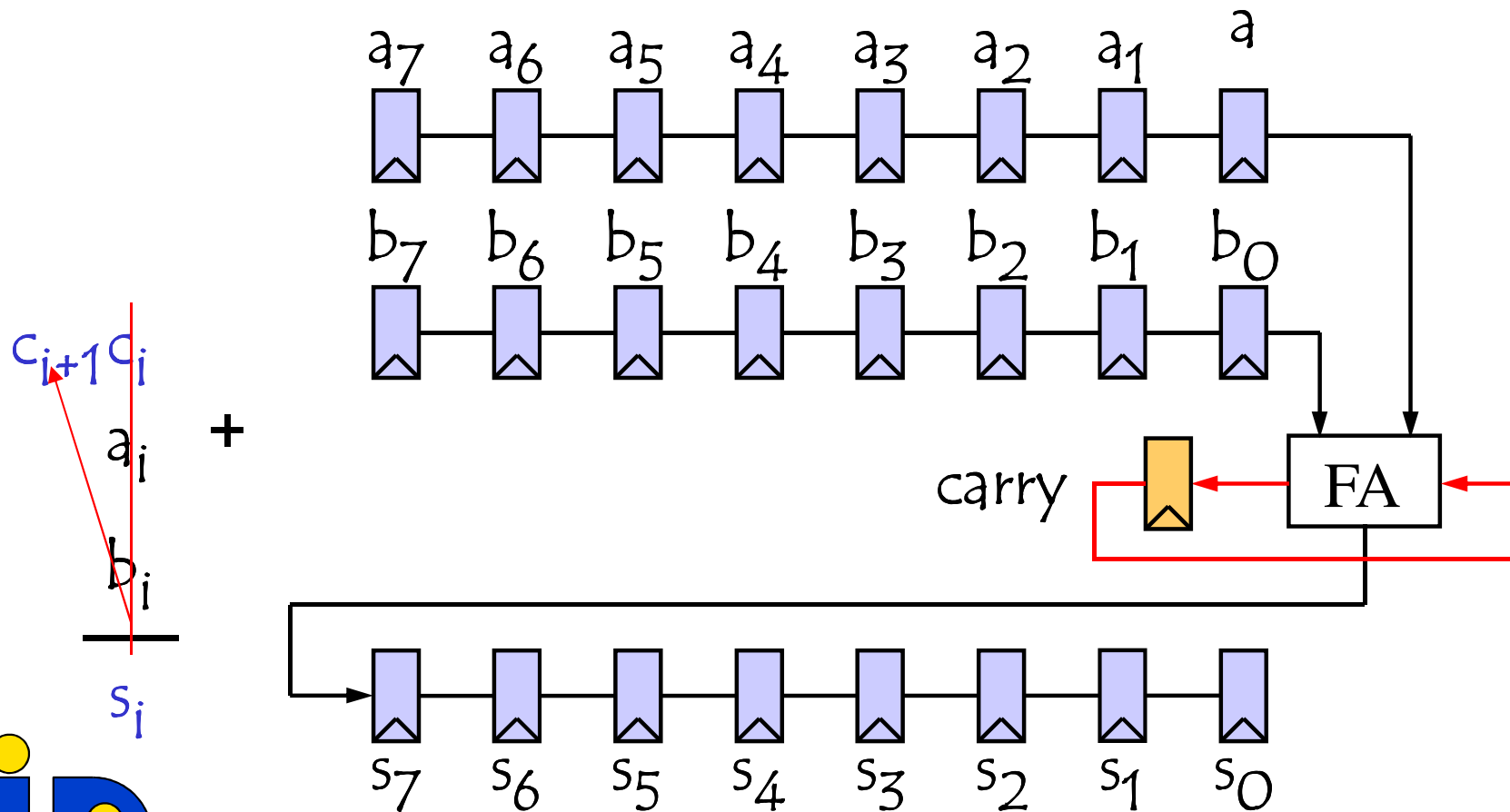

Adders

Adding two natural numbers

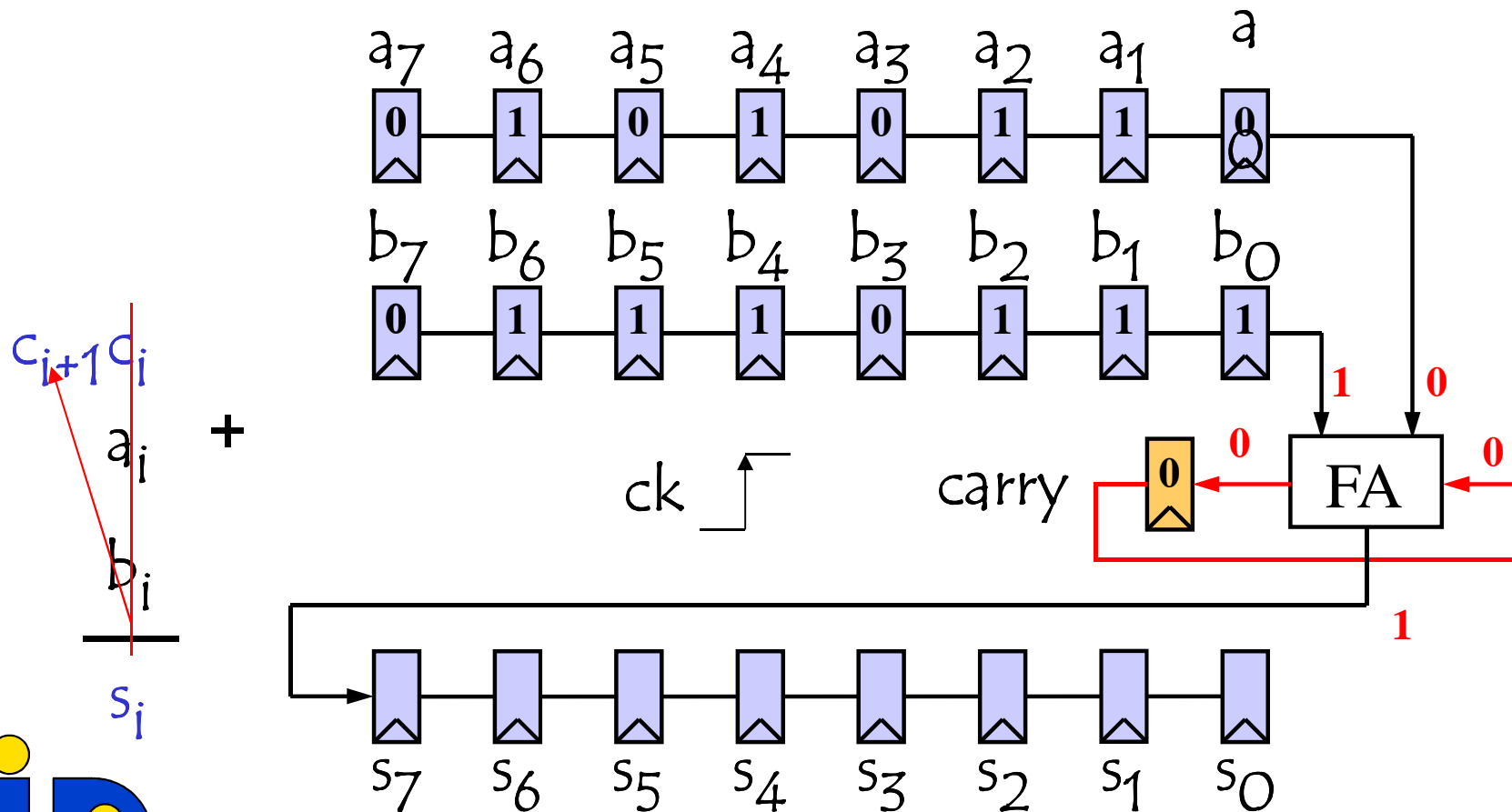

Adders

Adding two natural numbers

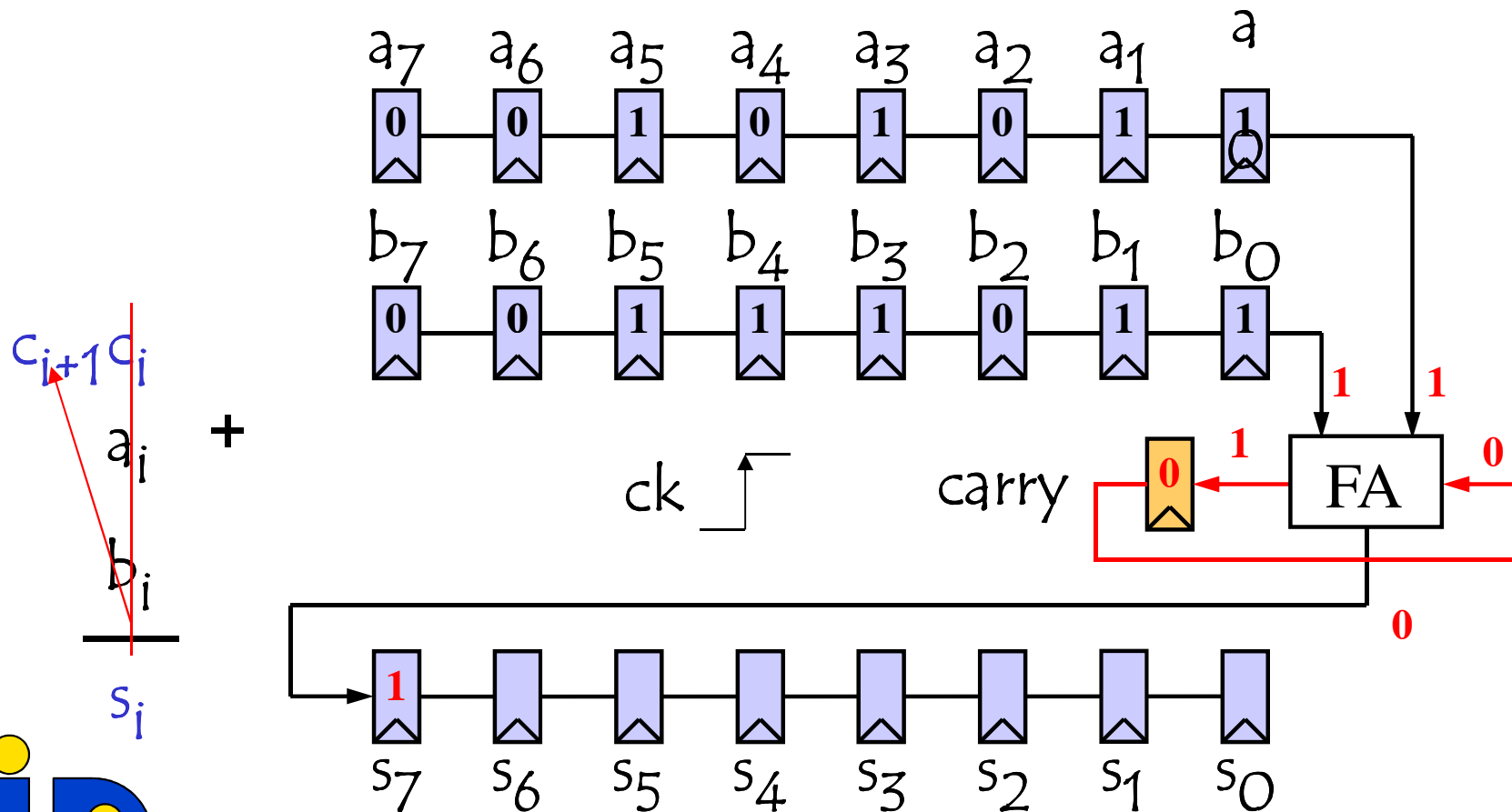

Adders

Adding two natural numbers

Sequential Adder

Area $\propto n$

Delay $\propto n$ cycles

Timing should be improved



Adders

Adding two natural numbers

At each stage, I need to sum 3 single bit numbers a_i b_i c_i

The carry out of the stage i is the input carry of the next stage

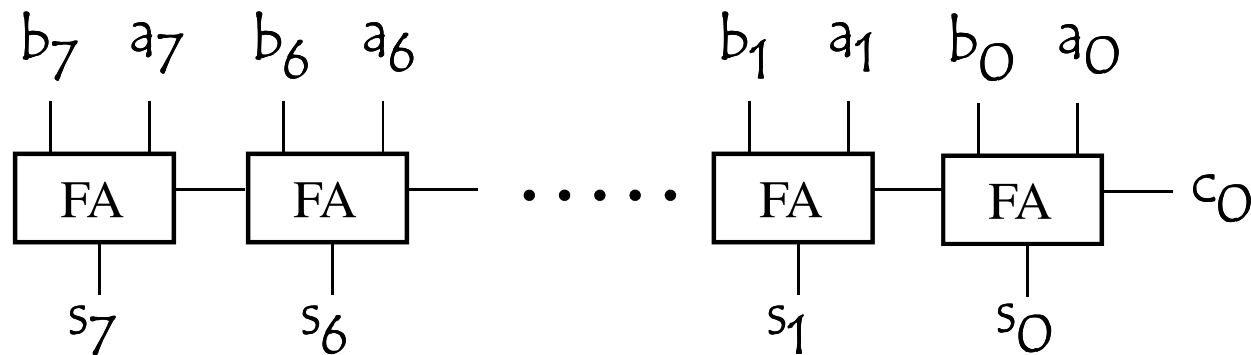

Ripple Carry Adder (RCA)

Adders

Adding two natural numbers

Ripple Carry Adder (RCA)

Area $\propto n$

Delay $\propto n$

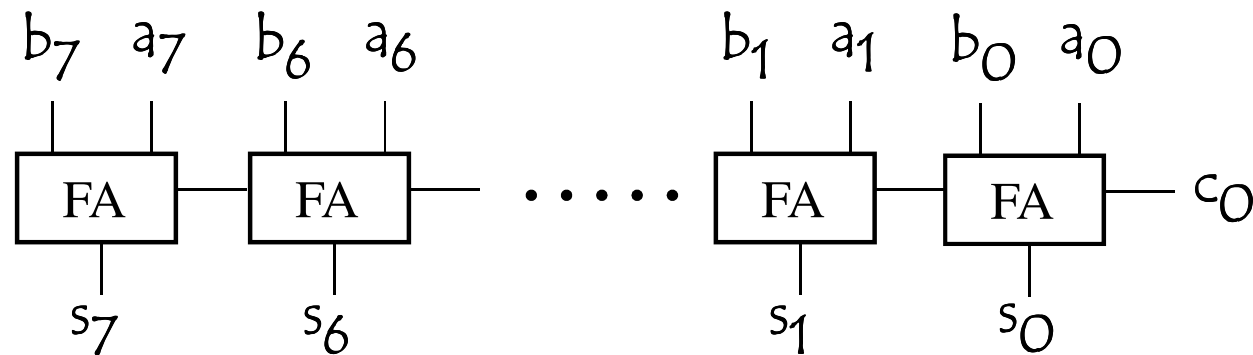

Timing should be improved

Adders

Adding two natural numbers

Acceleration techniques

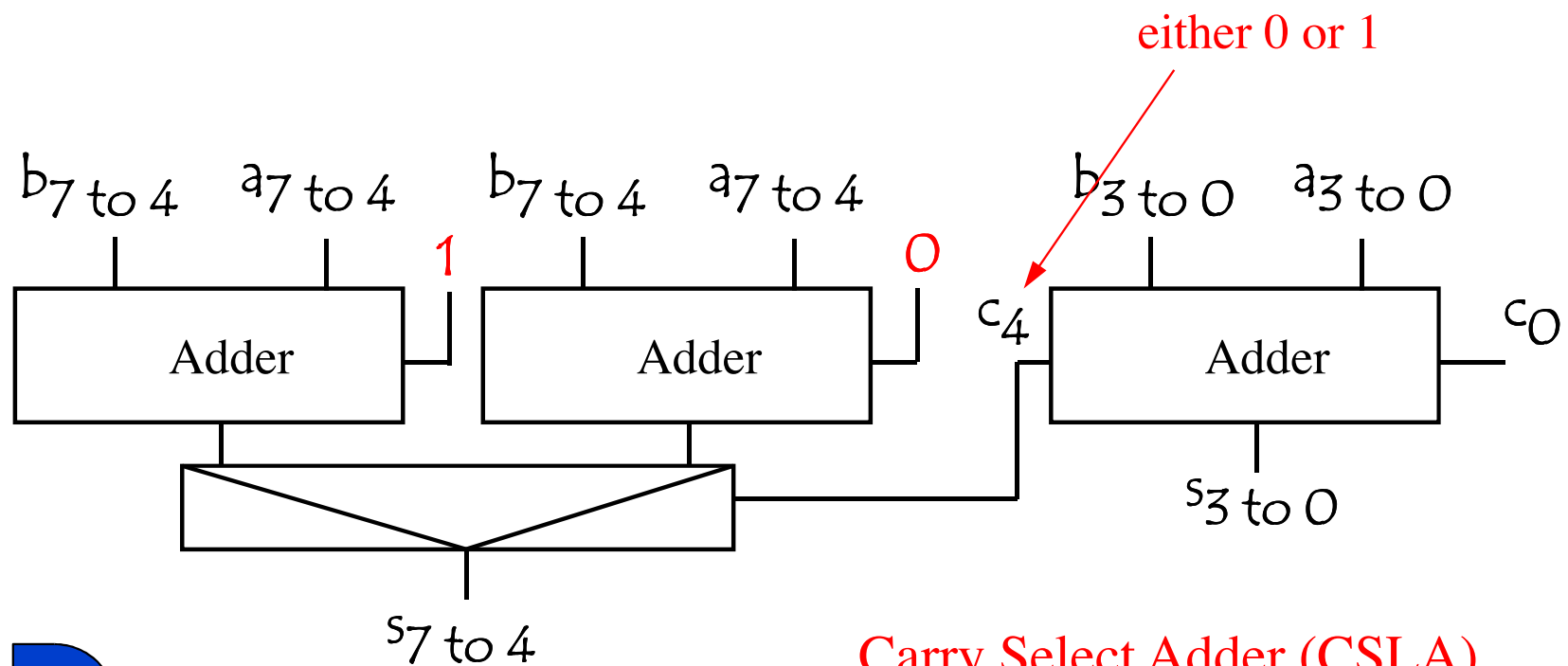

Carry Select Adder (CSLA)



Adders

Adding two natural numbers Carry Select Adder (CSLA)

$$\text{Area} \propto n^{\log(3)} = n^{1.585}$$

$$\text{Delay} \propto \log(n)$$

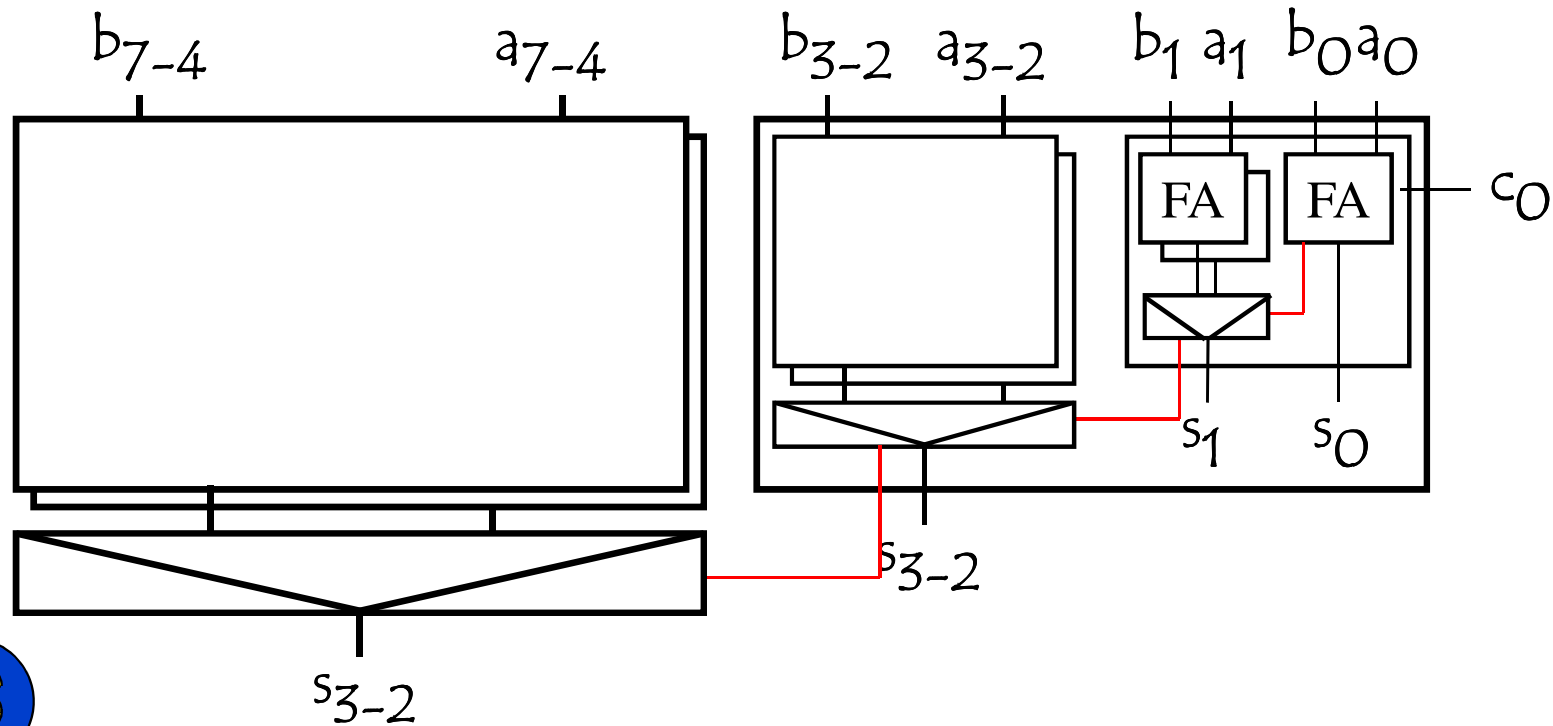

Adders

Adding two natural numbers Acceleration techniques

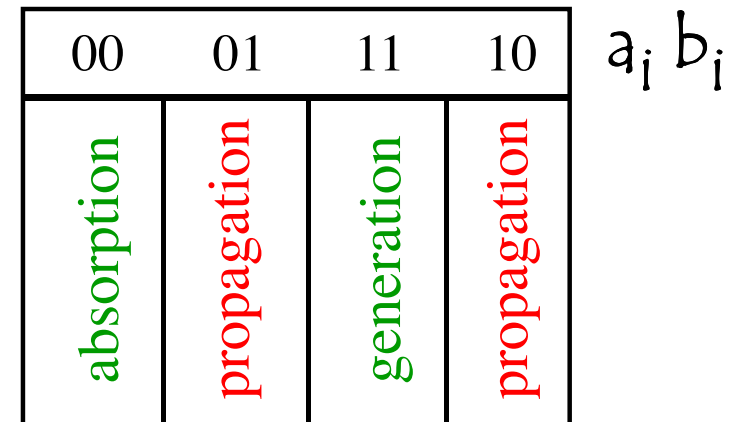
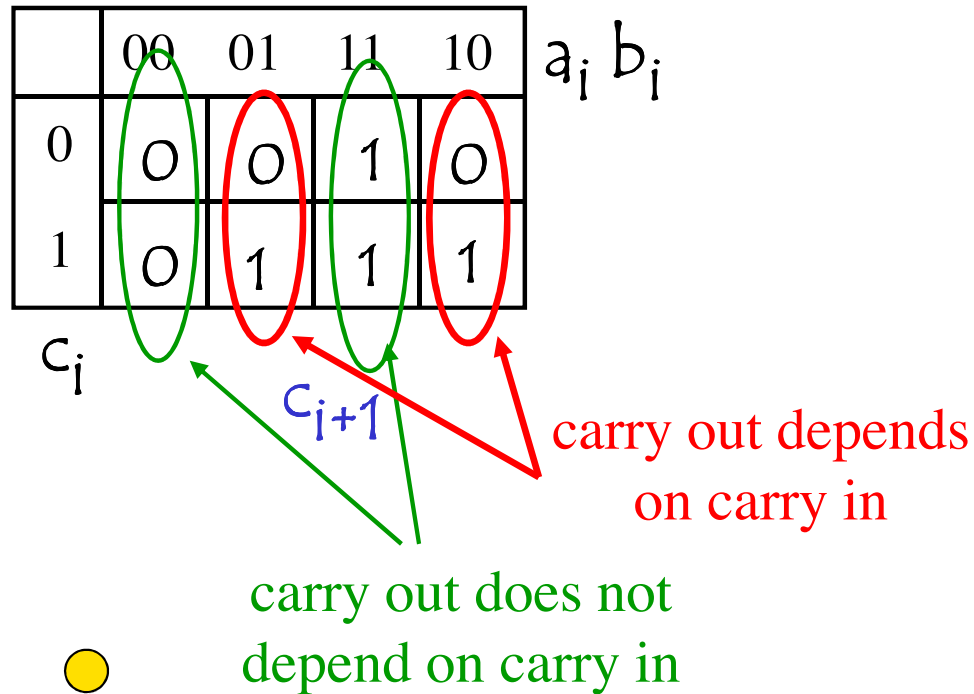

Adders

Adding two natural numbers Acceleration techniques

	00	01	11	10
0	0	0	1	0
1	0	1	1	1

$a_i b_i$

	00	01	11	10
$a_i b_i$	absorption	propagation	generation	propagation

$a_i b_i$

c_i

c_{i+1}

$$G_i = a_i b_i$$

$$P_i = a_i \oplus b_i$$

$$c_{i+1} = G_i + P_i c_i$$

$$s_i = P_i \oplus c_i$$

Adders

Adding two natural numbers Acceleration techniques

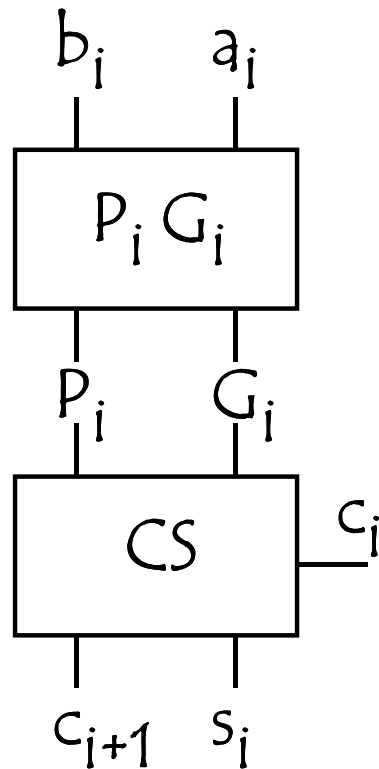

$$G_i = a_i b_i$$

$$P_i = a_i \oplus b_i$$

$$c_{i+1} = G_i + P_i c_i$$

$$s_i = P_i \oplus c_i$$

	00	01	11	10	$a_i b_i$
	absorption	propagation	generation	propagation	

Adders

Adding two natural numbers
Acceleration techniques

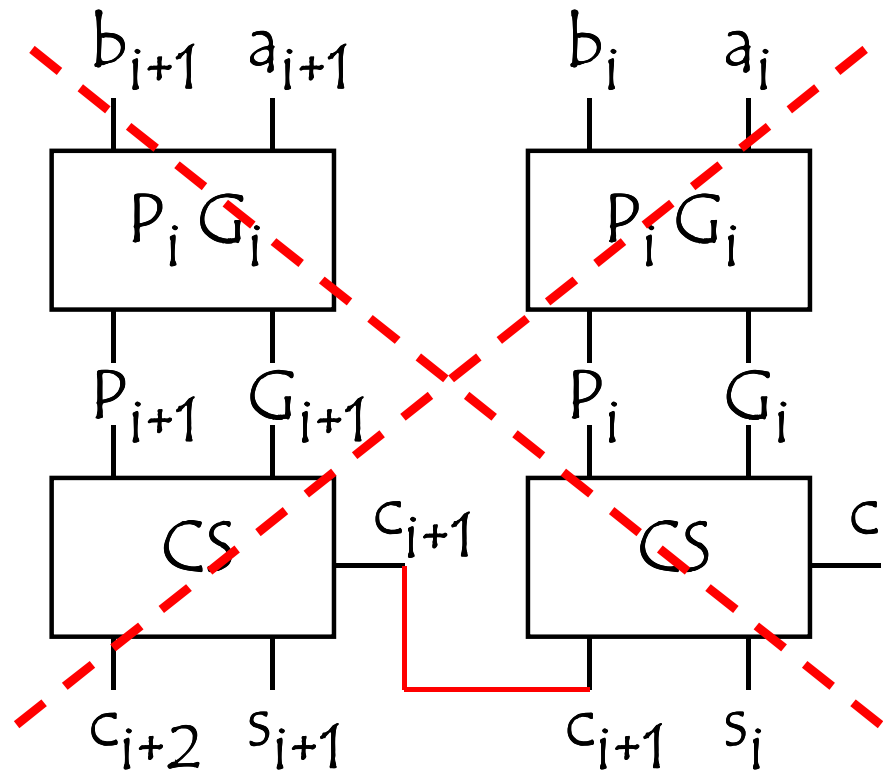

Adders

Adding two natural numbers Acceleration techniques

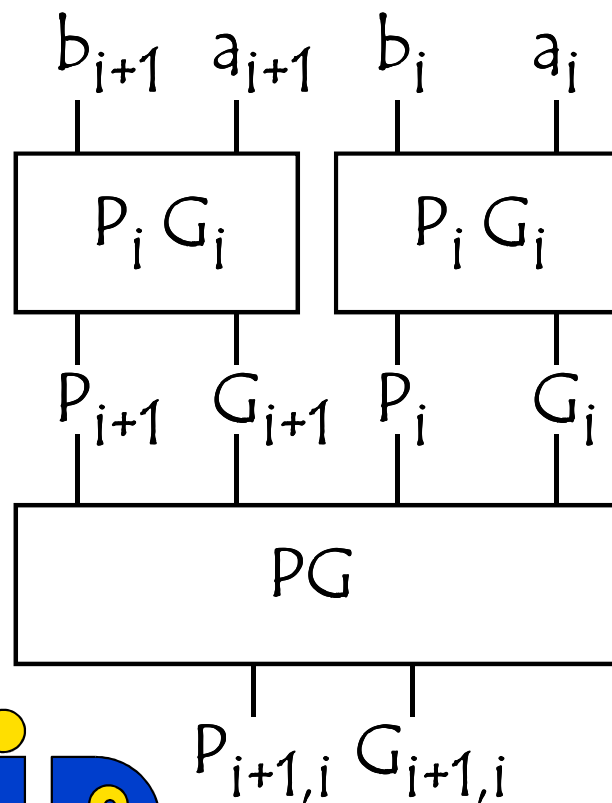

$$G_{i+1} = a_{i+1} b_{i+1} \quad G_i = a_i b_i$$

$$P_{i+1} = a_{i+1} \oplus b_{i+1} \quad P_i = a_i \oplus b_i$$

$$G_{i+1,i} = G_{i+1} + G_i \cdot P_{i+1}$$

$$P_{i+1,i} = P_i \cdot P_{i+1}$$

Adders

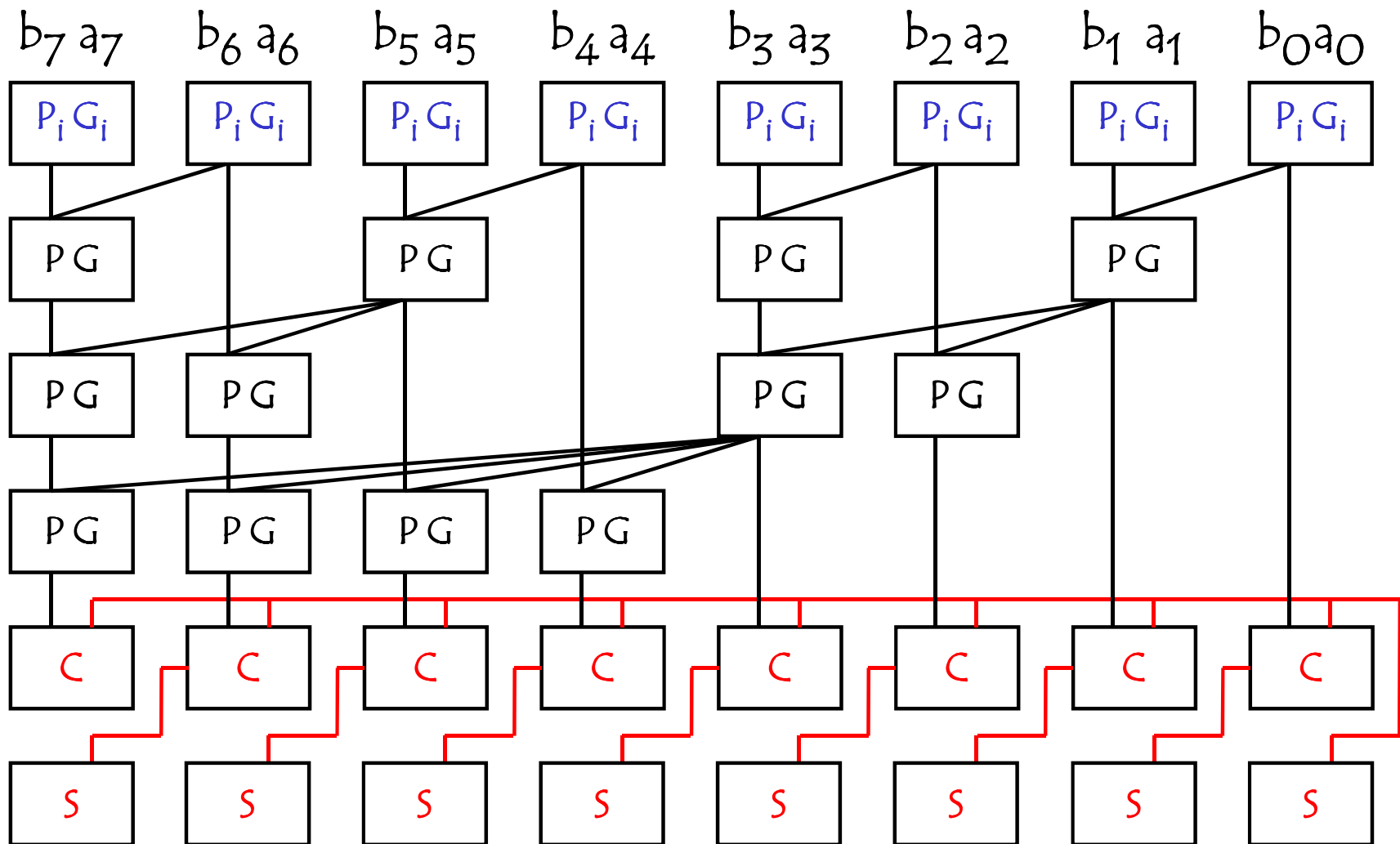

adders

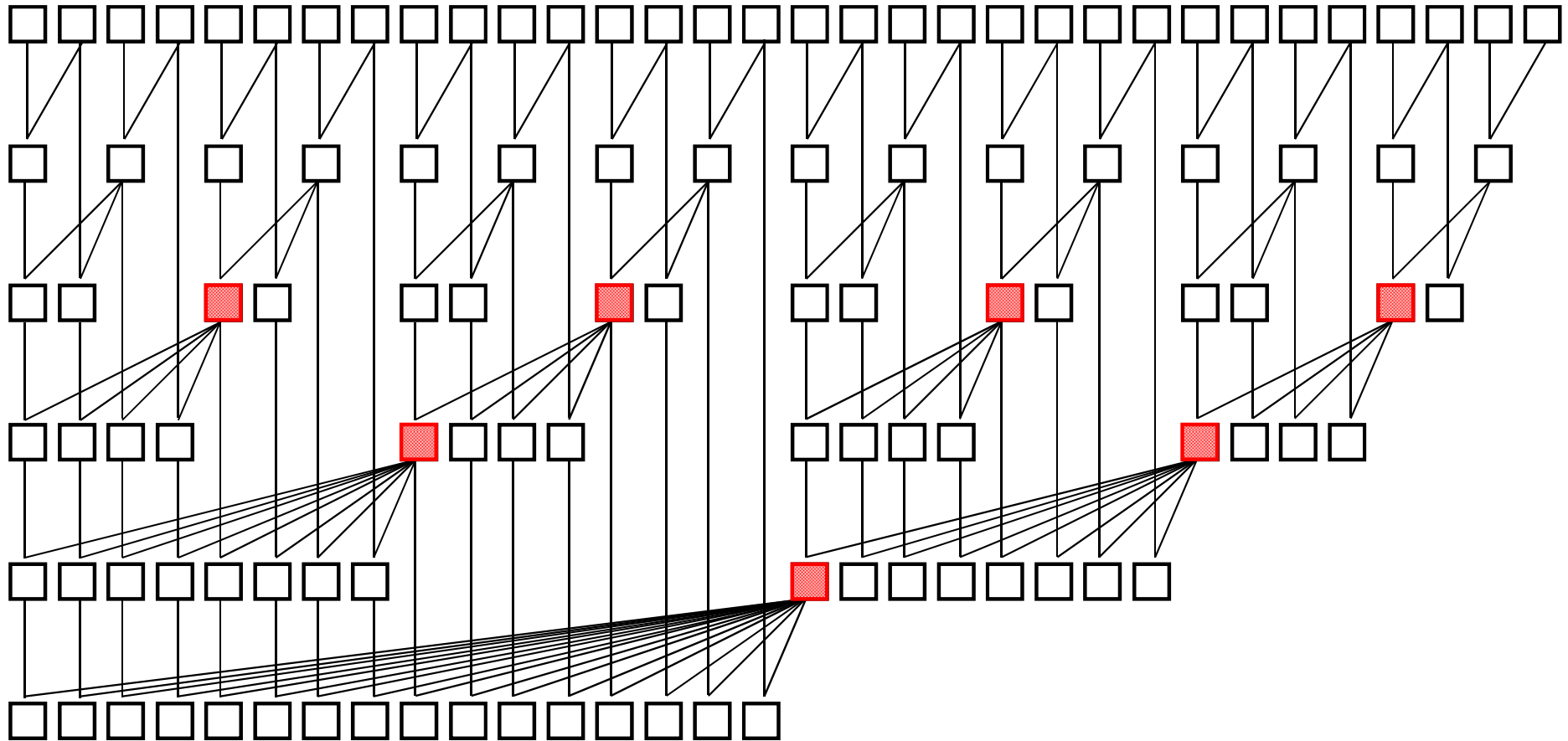

Slansky Adder

Adders

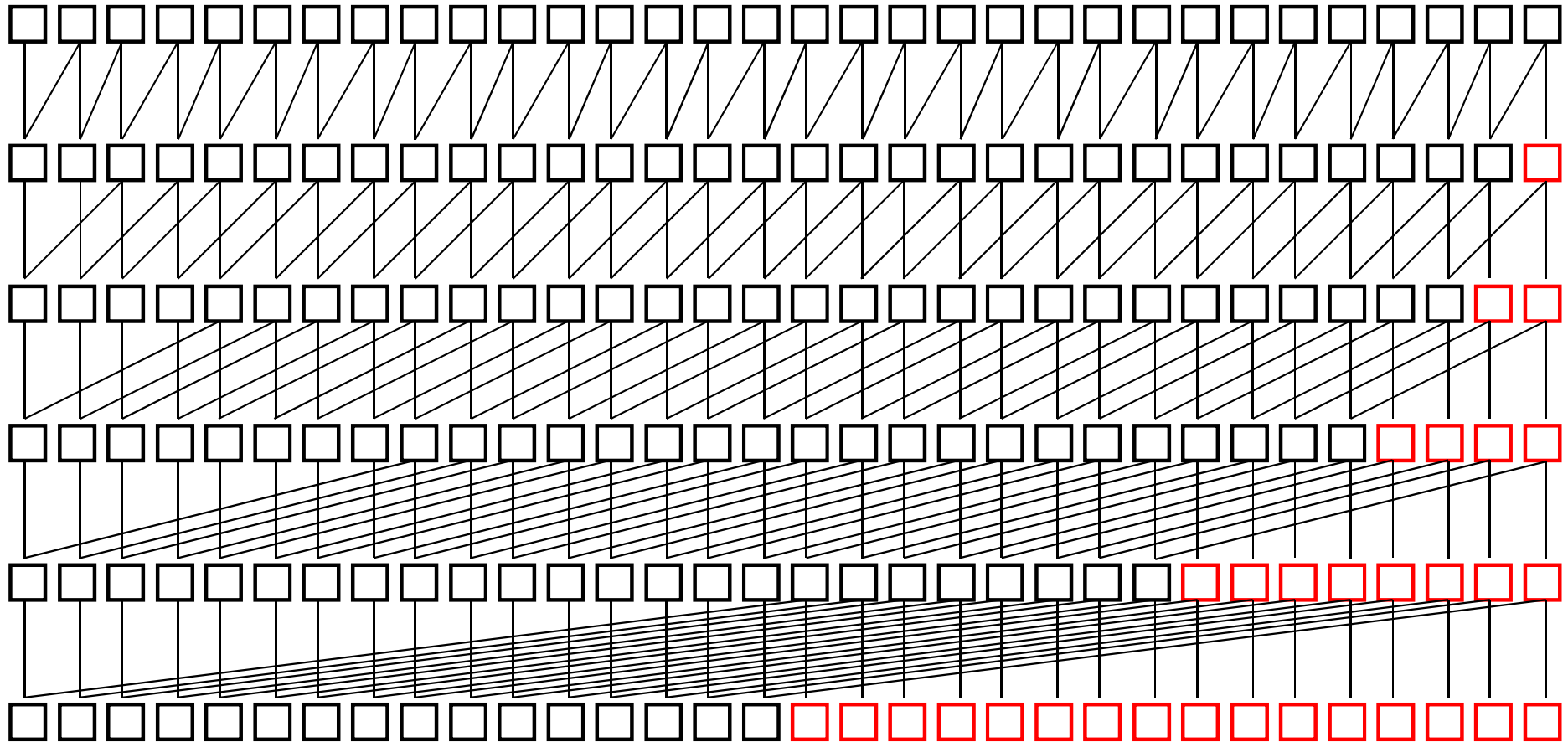

Kogge-Stone Adder

Adders

Adding two natural numbers (summary)

	Area	Delay
Ripple Carry (RCA)	n	n
Carry Select (CSLA)	$n \log(3)$	$\log(n)$
Carry Lookahead (CLA)	$n \log(n)$	$\log(n)$
Magic Adder	n	Cste

Adders

Adding two natural numbers

Ripple Carry Adder (RCA)

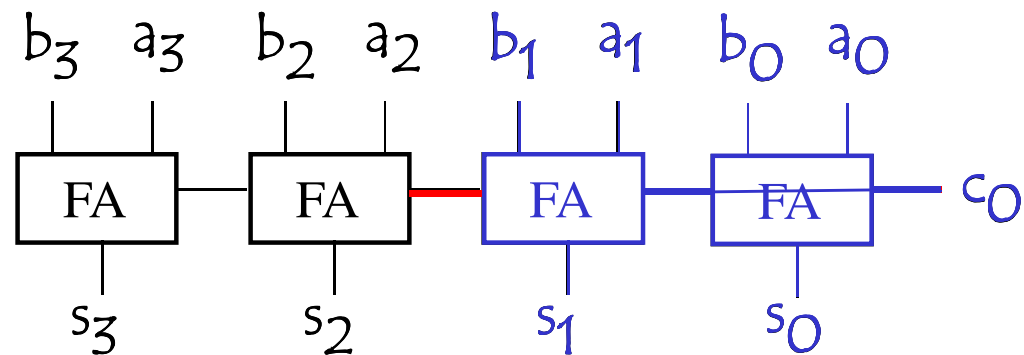

Adders

Adding two natural numbers

Ripple Carry Adder (RCA)

pipelining

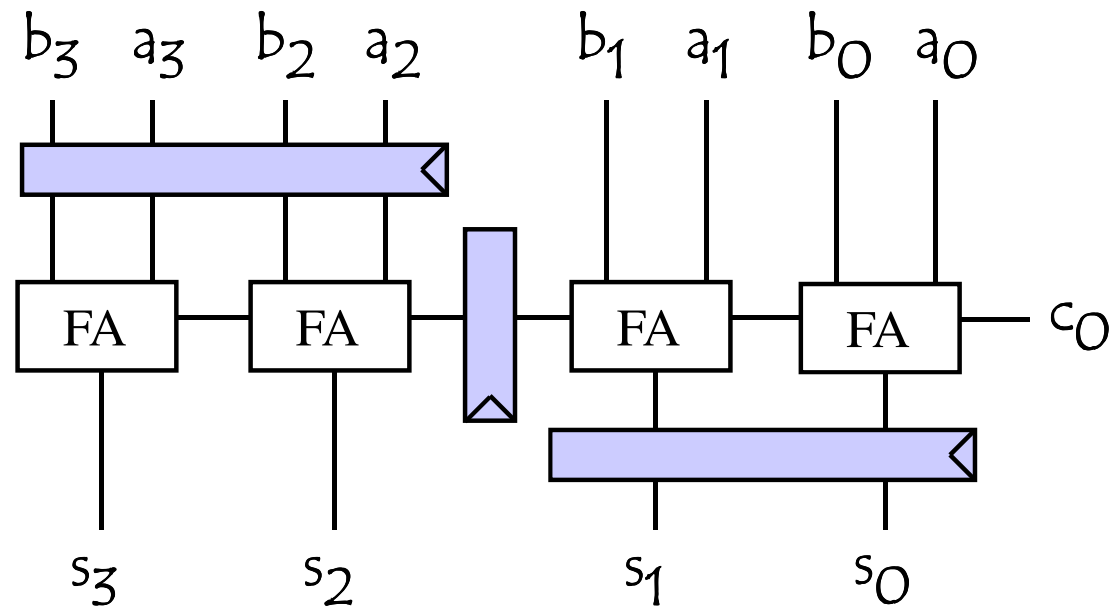

Adders

Adding two natural numbers

Ripple Carry Adder (RCA)

pipelining

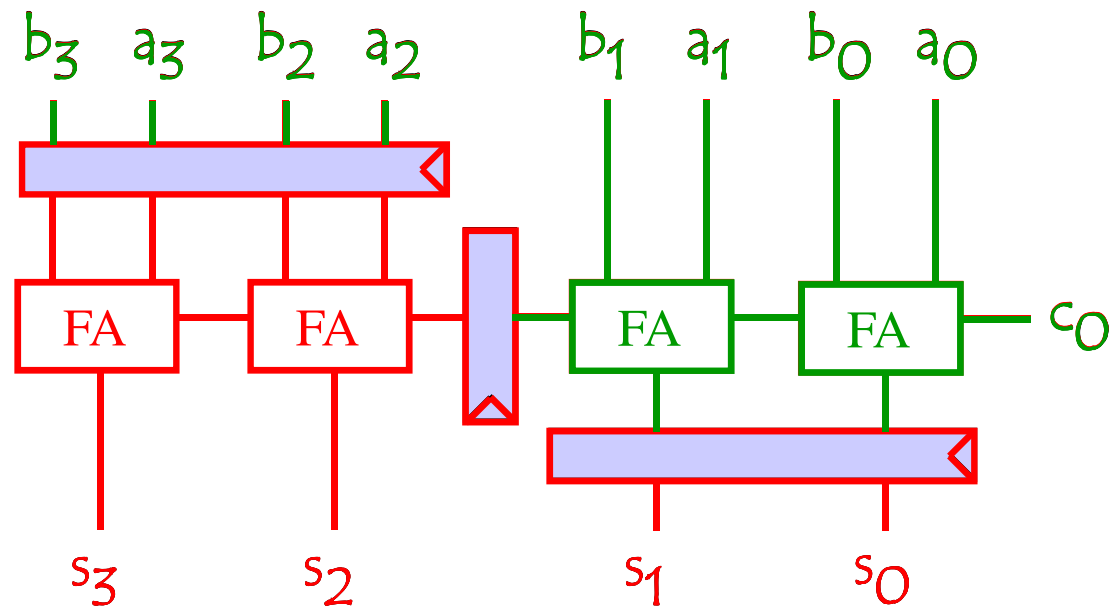

Adders

Adding two natural numbers

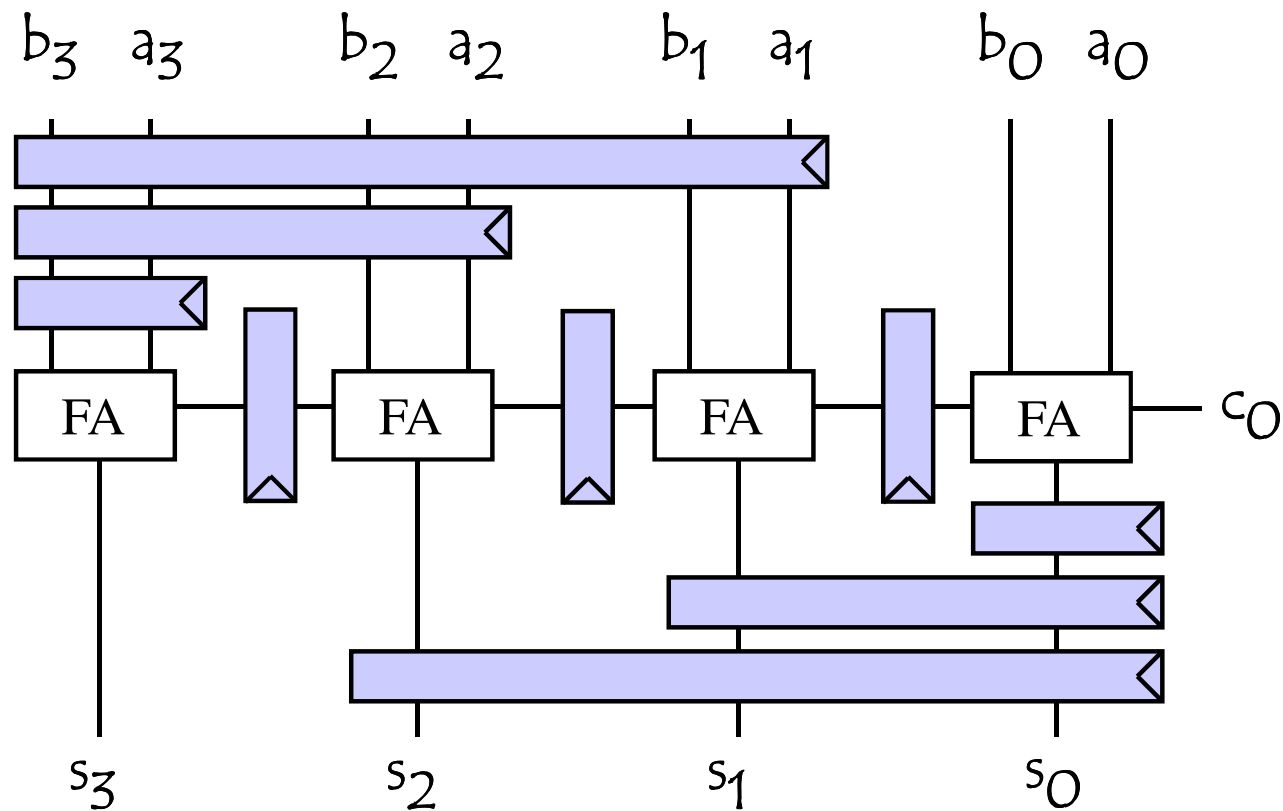

Adders

Adding two natural numbers (summary)

	Area	Delay
Ripple Carry (RCA)	n	n
Carry Select (CSLA)	$n \log(3)$	$\log(n)$
Carry Lookahead (CLA)	$n \log(n)$	$\log(n)$
Pipeline Adder	n^2	Cste (1 cycle)
Magic Adder	n	Cste



When there is no door to escape break the wall

Adders

Adding **three** natural numbers

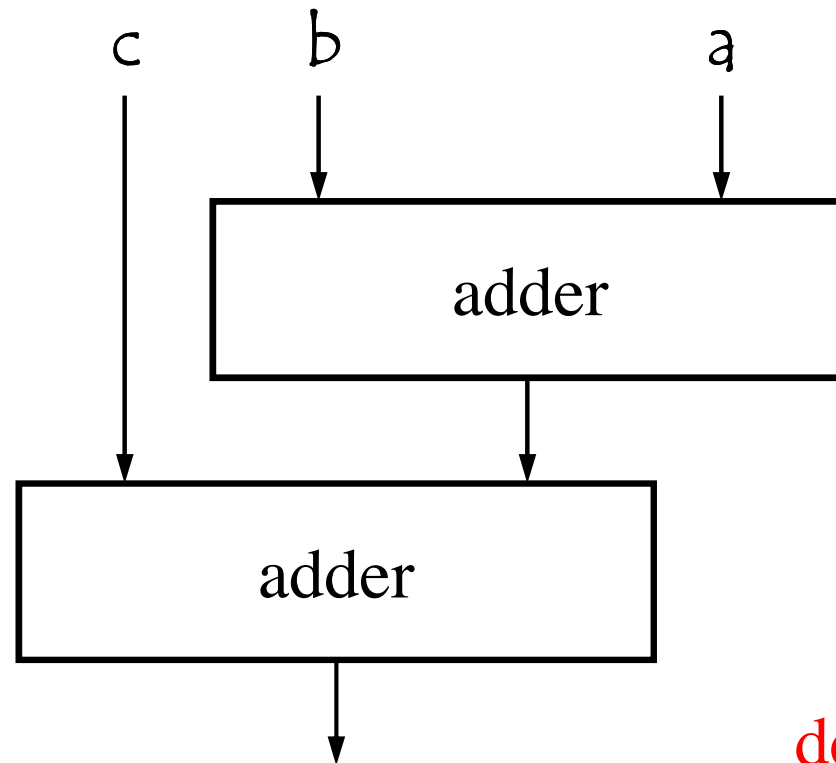

delay

Adders

Adding **three** natural numbers

$$s_i = a_i \oplus b_i \oplus c_i$$

$$c_{i+1} = a_i \cdot b_i + a_i \cdot c_i + b_i \cdot c_i$$

the expressions are symmetrical in regard of a, b and c

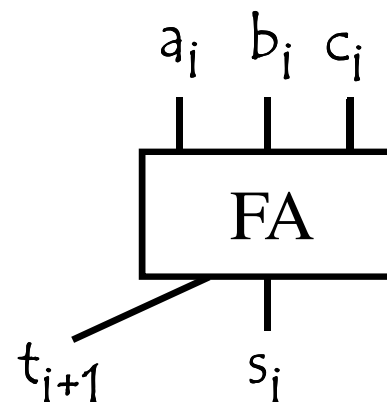

**A full adder creates 2
numbers from 3**

Adders

Adding **three** natural numbers

Carry Save Adder (CSA)

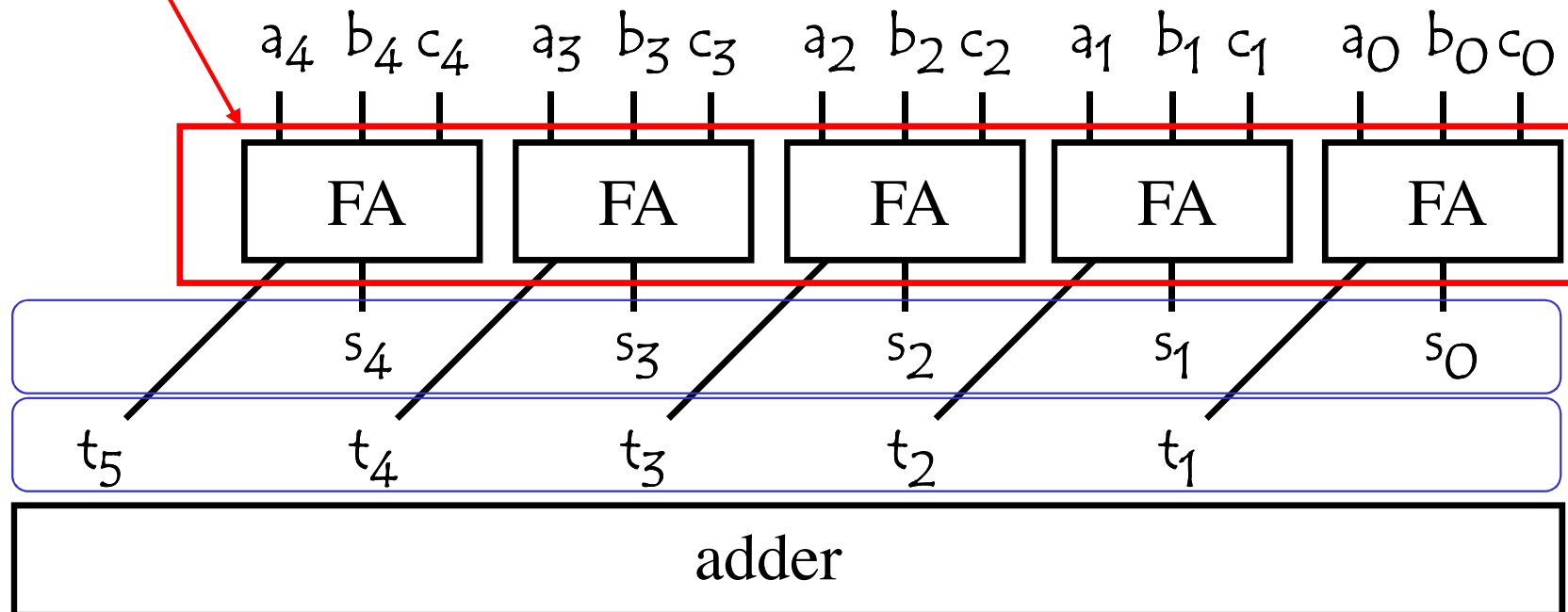

Adders

Adding **three** natural numbers

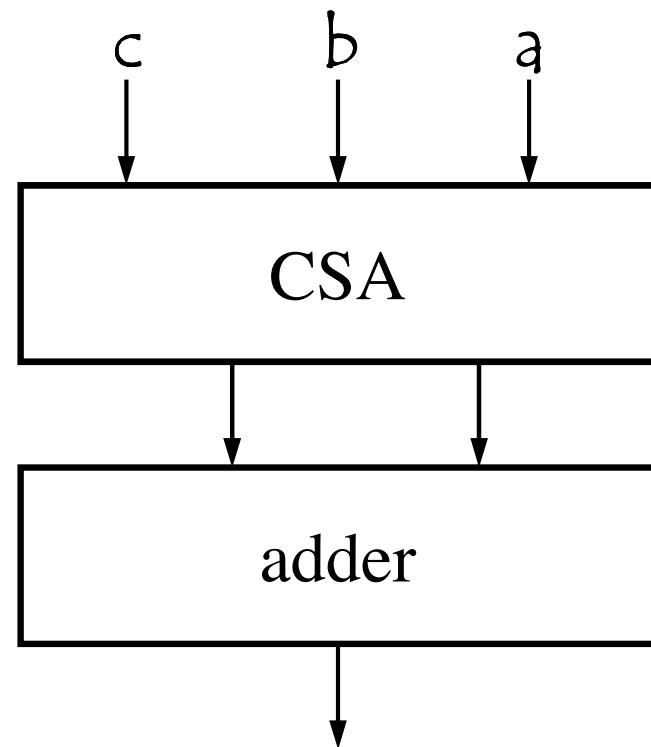

Delay = cste
Area $\propto n$

Adders

Adding two natural numbers

Change the representation of numbers

Given a natural number a : a is coded using $2n$ bits

$$a = a_0 + a_1 \quad \text{Redundant Binary Code}$$

Example : the number 5 can be coded on 4 bits as

$$0000 + 0101$$

$$0001 + 0100$$

$$0010 + 0011$$



Adders

Adding two natural numbers

Changing the representation of numbers

$$a = a_0 + a_1$$

$$b = b_0 + b_1$$

Adding a and b in Redundant Binary Code is finding c

$$c = c_0 + c_1 \text{ such as}$$

$$c_0 + c_1 = a_0 + a_1 + b_0 + b_1$$

Adding 4 numbers to generate 2



Adders

Adding two natural numbers

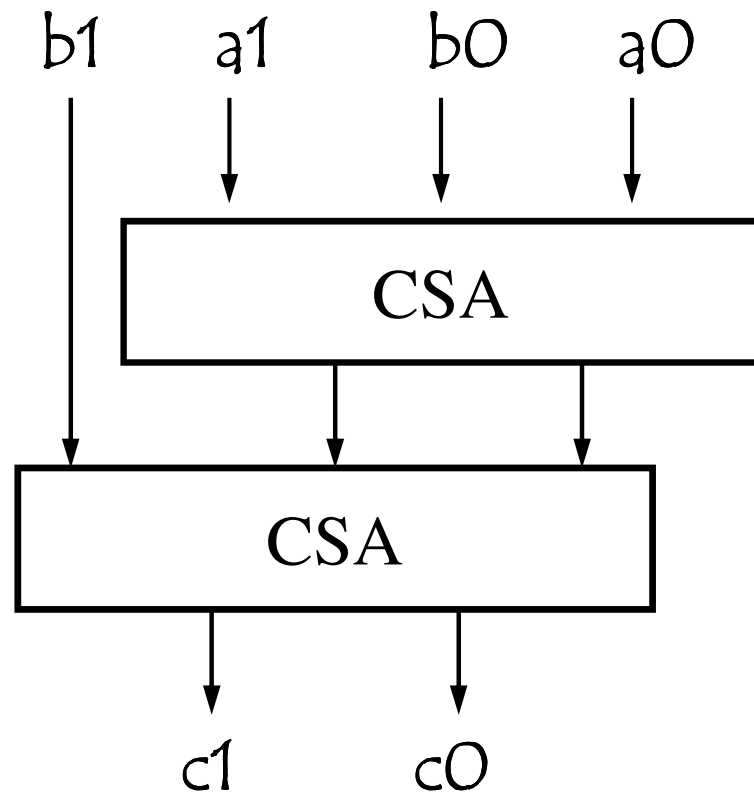

Delay = cste
Area $\propto n$